



Designer Collection Tubs

Wyndham 5

MODEL # 80
59.75" x 32" x 23"

GENERAL SPECIFICATIONS

Material - Acrylic

Installation - Alcove

Plumbed Weight - 129 lbs / 59 kg

Soaker Weight - 105 lbs / 48 kg

Average Fill - 34 gal to above jet level

Maximum Fill - 51 gal to overflow

NOTE: Filling this tub to the maximum may require an above average size or dedicated water heater.

Wyndham 5 features integral skirting, tile flange, armrests and a pre-leveled foam base.

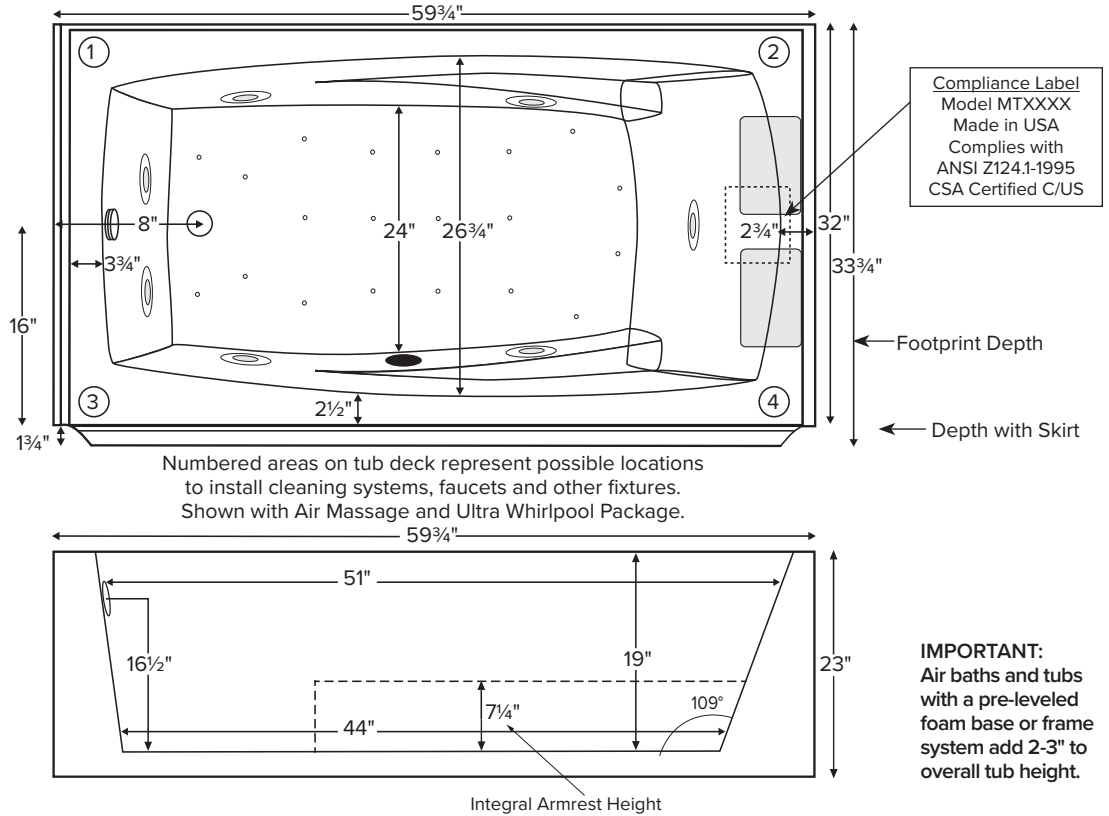

IMPORTANT ORDERING & INSTALLATION INFORMATION

- Before ordering or installing, please consider future access to equipment.
- When equipped with any hydrotherapy package or select options such as Radiance® or HTI Soak, front panel is removable for access. Some hydrotherapy components may require end-access. Contact MTI for more information before ordering.
- Must specify left- or right-hand drain when ordering.
- This tub model is designed to install on a flat, level subfloor.
- Radiance placed on airbath floor will affect placement of air jets.
- System components may extend beyond the perimeter of deck.
- Advise MTI when planning to use a glass enclosure. Relocation of controls may be necessary.
- Suction and control locations may vary.

ELECTRICAL COMPONENTS & SPECIFICATIONS

Hydrotherapy Package	Components Included	GFCI / 110V
Standard Whirlpool	2-bhp pump	1-15 amp
Stream Bath	½-bhp	1-15 amp
Microbubbles	Microbubbles pump	1-15 amp
Ultra Whirlpool	2-bhp pump x 2, inline heater, ozone	2-20 amp
Air Massage	heated blower	1-15 amp
Air Massage Elite	heated blower, chromatherapy	1-15 amp
Air Massage w/ Stream Bath	½-bhp pump, heated blower	1-15 amp
Air Massage Elite w/ Stream Bath	½-bhp pump, heated blower, chromatherapy	1-15 amp

Hydrotherapy Package	Components Included	GFCI / 110V
Microbubbles with Air	Microbubbles pump, heated blower	1-20 amp
Microbubbles with Air Elite	Microbubbles pump, heated blower, chromatherapy	2-15 amp
Air with Whirlpool	2-bhp pump, heated blower	2-15 amp
Air with Ultra Whirlpool	2-bhp pump x 2, inline heater, heated blower, ozone	2-20 amp
Air Elite with Whirlpool	2-bhp pump, heated blower, chromatherapy	2-15 amp
Air Elite with Ultra Whirlpool	2-bhp pump x 2, inline heater, heated blower, chromatherapy, ozone	2-20 amp

See the Installation & Operation Manual for more details.
MTI's Customer Service Monday-Friday 8am-6pm EST
800-783-8827 or service@mtibaths.com

- Before discarding tub crate, check for accessories that may be packaged inside.
- All product measurements are ±1/2".
- Specifications and configurations are subject to change without notice.
- Measurements herein supersede all others published prior to publication date below.

