

# CHAIR & TABLE COMPANY

## Assembly Instructions WINDSOR ARM BENCH



NO	PART LIST	QTY
1	Leg Frame - Left	1 PC
	- Right ( F/R )	1 PC
2	Stretcher	2 PCS
3	Wooden Seat	1 PC
4	Chair Back Frame	1 PC
5	Assembly Arm Rest - Left	1 PC
	- Right	1 PC

NO		HARDWARE LIST	QTY
A		Flat Washer - Dia 12mm	18 PCS
B		Spring Washer - Dia 12mm	18 PCS
C		Short JCBC Bolt M6 x 35mm	10 PCS
D		Long JCBC Bolt M6 x 60mm	4 PCS
E		Long JCBC Bolt M6 x 60mm	4 PCS
F		Barrel Nut	8 PCS
G		Big Wood Bottom - Dia 14.5mm	6 PCS
H		Allen Key M4	1 PCS
I		Small Wood Bottom - Dia 11.5mm	2 PCS

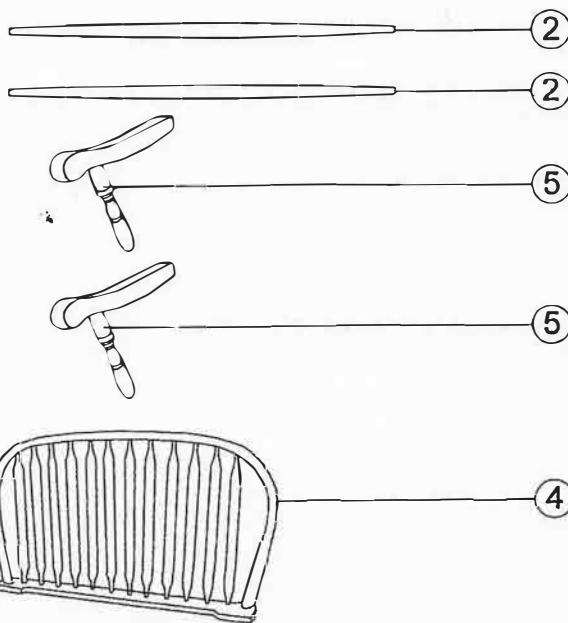
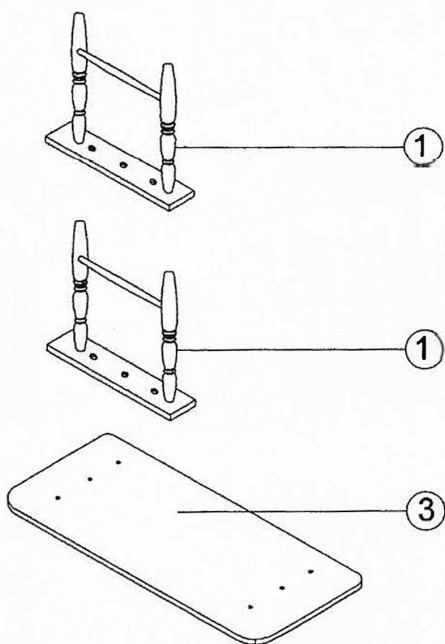

### IMPORTANT NOTE :

Place all wooden part on a clean and smooth surface such as a rug or carpet to avoid the parts from being scratched.

- Check to be sure that you have all part and hardware. Remove all wrapping materials, including staples & packing straps before you start to assemble. Do not tighten all screws/ bolts until all completely assembled
- Keep all hardware part out of reach of children.
- DO NOT TIGHTEN BOLTS/SCREWS UNTIL ALL COMPLETELY ASSEMBLED.

Assembly Instructions  
WINDSOR ARM BENCH

1

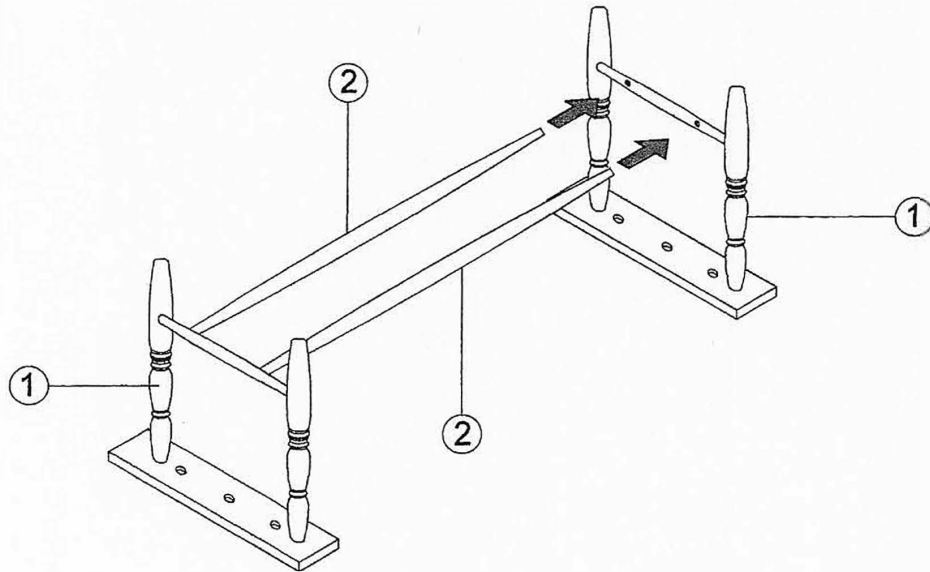

2

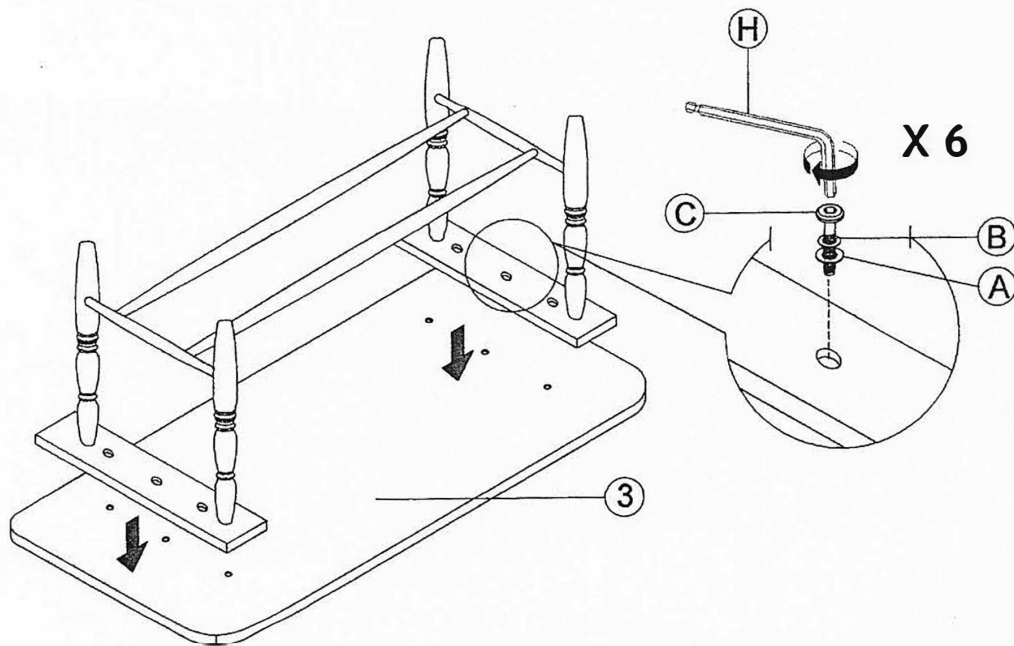

Assembly Instructions  
WINDSOR ARM BENCH

3

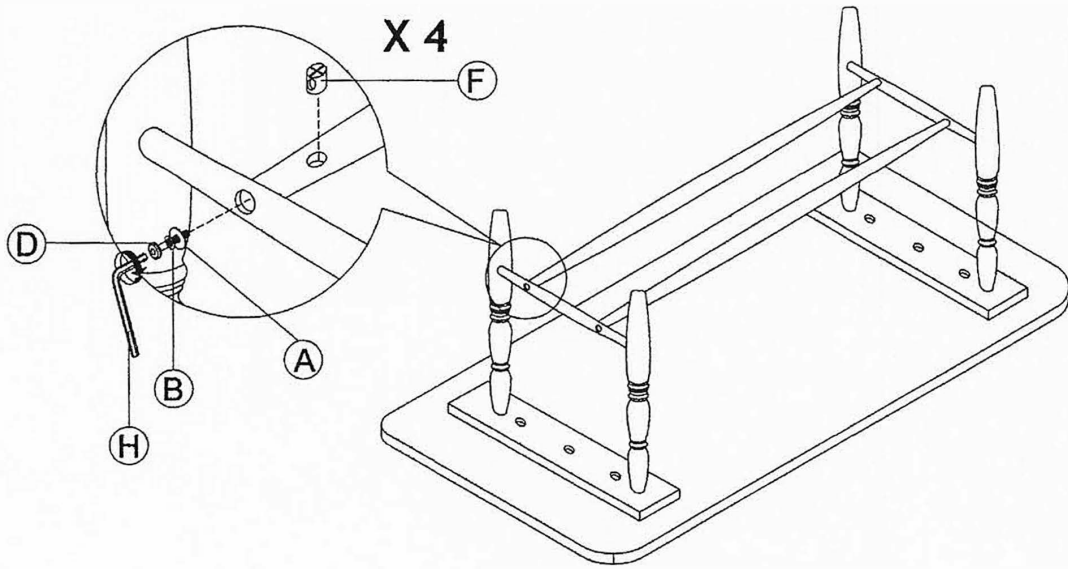

4

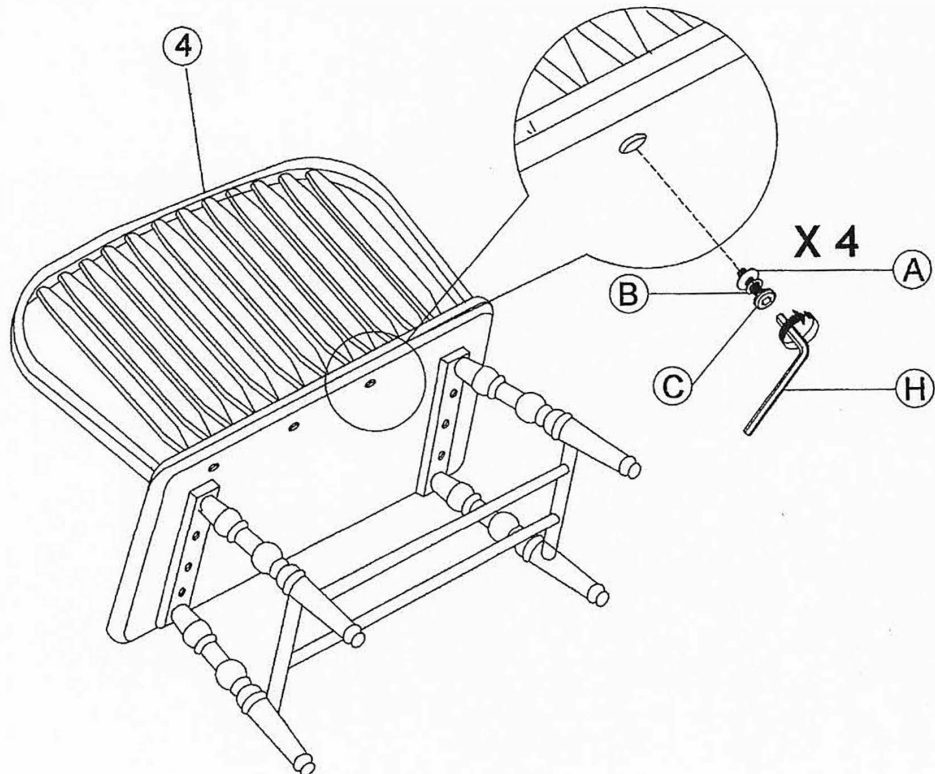

Assembly Instructions  
WINDSOR ARM BENCH

5

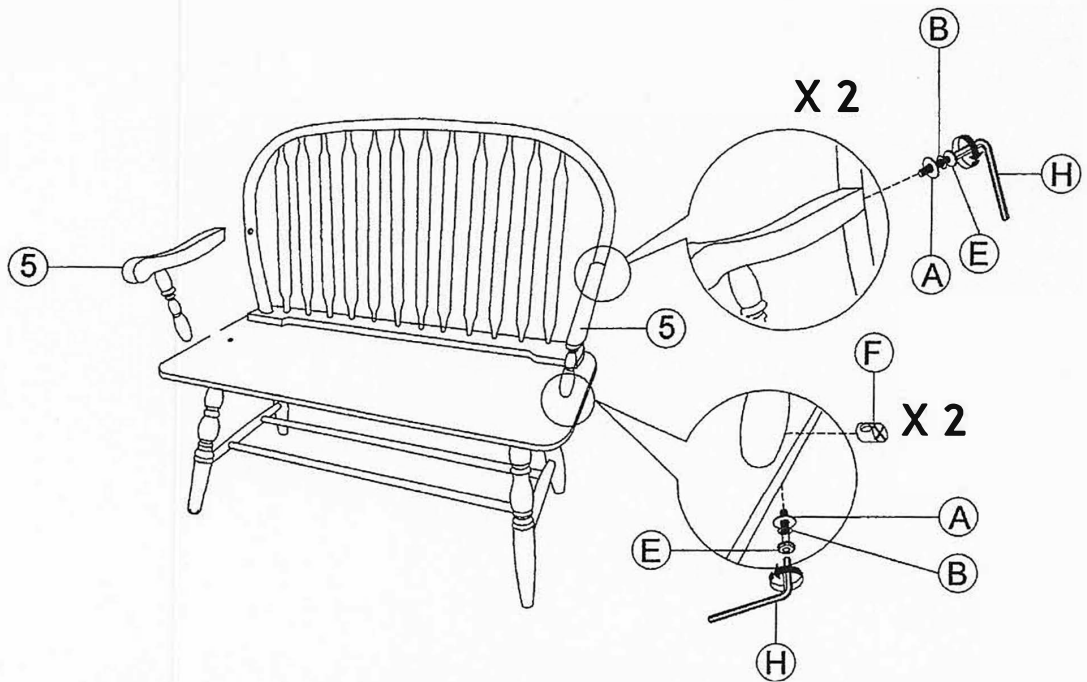

6

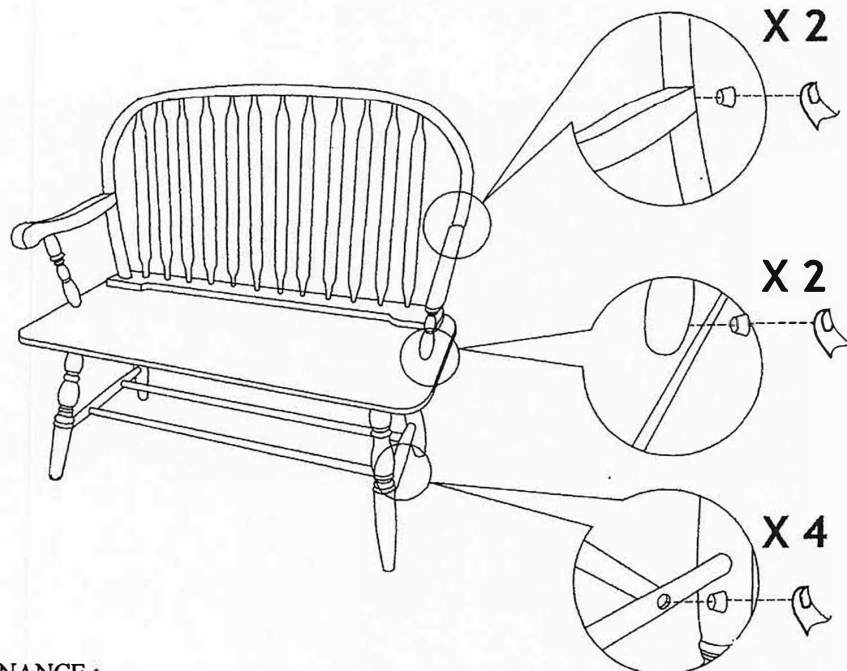

CARE AND MAINTENANCE :

The touce of a soft cloth is all the maintenance your wood dieces will ever naad. Never use harsh chemicals or abrasive cleaners, as they could mark or destroy finish.

## **CARE INSTRUCTIONS**

**Thank you for your purchase. Our items are intended for residential use only.**

**To clean and maintain your furniture we recommend dry dust with a soft clean cloth.**

**Do not use harsh chemicals to clean your furniture as this could damage the protective top coat and/or finish.**