

ASSEMBLY INSTRUCTIONS

Thank you for purchasing our product.

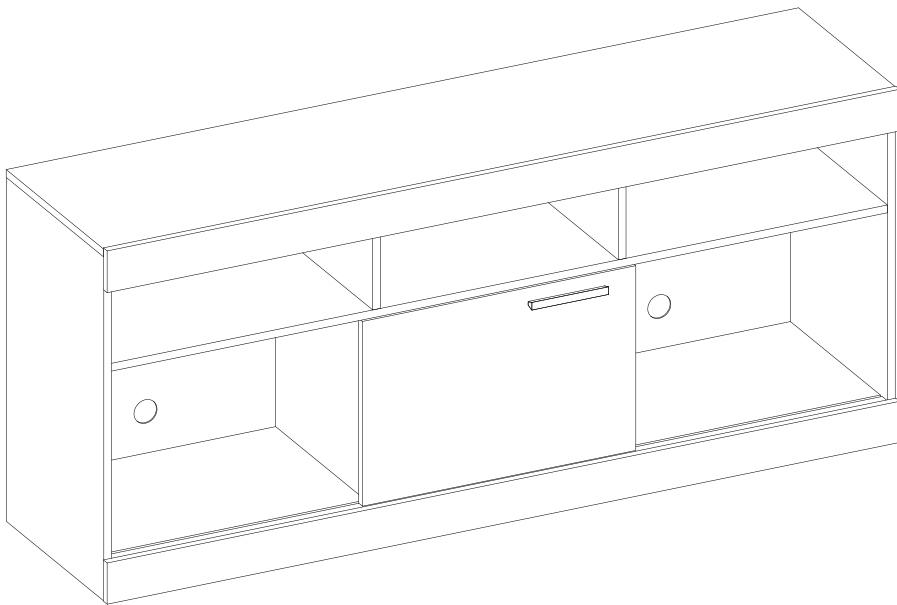



- Please read carefully the assembly instructions before the installation.









- Do not discard this manual or any of the packaging material until the unit has been completely assembled.

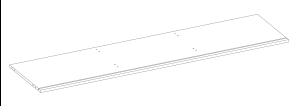



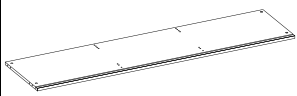
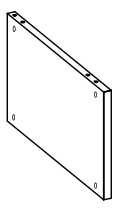
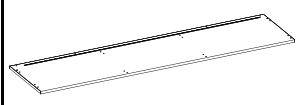

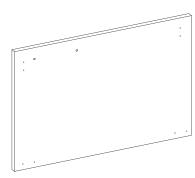
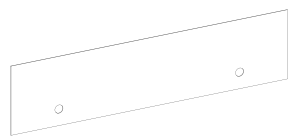
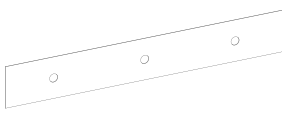
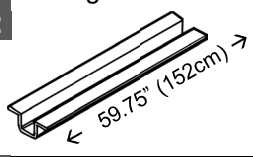
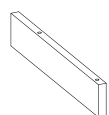

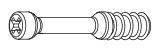

- Might require two people.

MAIN PARTS LIST

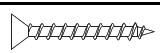
| | | | |
|--|---|--|---|
| <p>1 Bottom panel x1</p>  | <p>2 Right panel x1</p>  | <p>3 Partition panel, bottom x2</p>  | <p>4 Left panel x1</p>  |
| <p>5 Middle panel x1</p>  | <p>6 Partition panel, top x2</p>  | <p>7 Top panel x1</p>  | <p>8 Front panel, top and bottom x2</p>  |
| <p>9 Sliding door x1</p>  | <p>10 Back panel, bottom x1</p>  | <p>11 Back panel, top x1</p>  | <p>12 Sliding track x2</p>  <p>59.75" (152cm)</p> |
| | | | <p>13 Support panel, bottom center x1</p>  |

LIST OF HARDWARE, SCREWS AND FITTINGS

| PART | QTY | ITEM | |
|----------|-----|------------------------|---|
| A | 30 | M6x30 Dowels |  |
| B | 20 | M5x31 Bolts |  |
| C | 20 | M2x9 Cam locks |  |
| D | 30 | ST3.5x12 |  |
| E | 8 | ST3.5x40 |  |
| F | 2 | ST3.5x25 |  |
| G | 15 | Plastic corner bracket | |
| H | 7 | Ø12x6mm Glide studs |  |

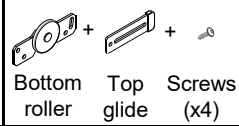
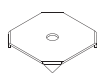
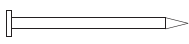
| PART | QTY | ITEM | |
|----------|--------|--|---|
| I | 12 | Ø15mm Plastic adhesive stickers |  |
| J | 1 | 128mm Handle |  |
| K | 2 sets | Bottom roller with top glide and screws for door |  |
| L | 10 | 13x13mm Metal junction caps for nails |  |
| M | 50 | 22*Ø2mm Nails |  |
| N | 1 | Touch-up chalk | |

NOTE: You will need for the assembly a Phillips screwdriver and mallet/hammer (not included).

MAIN PARTS LAYOUT (FOR REFERENCE):

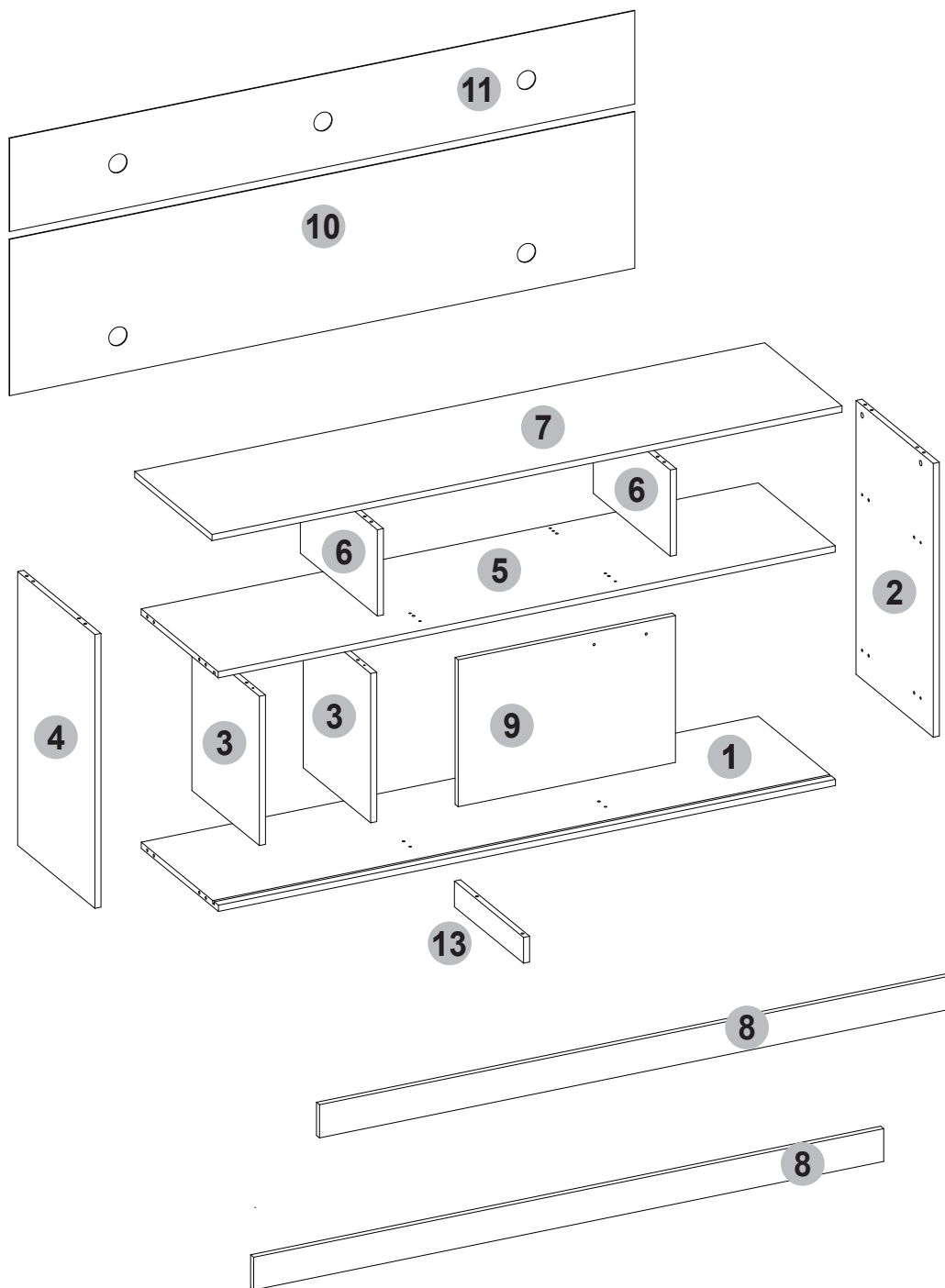

☛ This unit uses cam bolts and locks. The following explains how to use them. This is not an assembly step; it is a guide for when you are actually doing the assembly using this kind of hardware.

Cam Lock



Cam Bolt

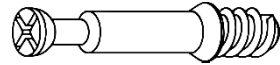

1. Screw the bolt into the corresponding hole on panel "A".

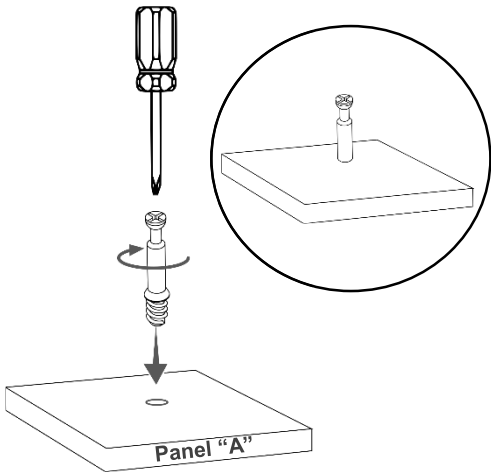

2. Join panel "B" to panel "A". If panel "B" comes with the cam lock pre-installed, make sure it is aligned to receive the bolt's head (refer to point 3). There might be a very small gap between the panels which is normal.

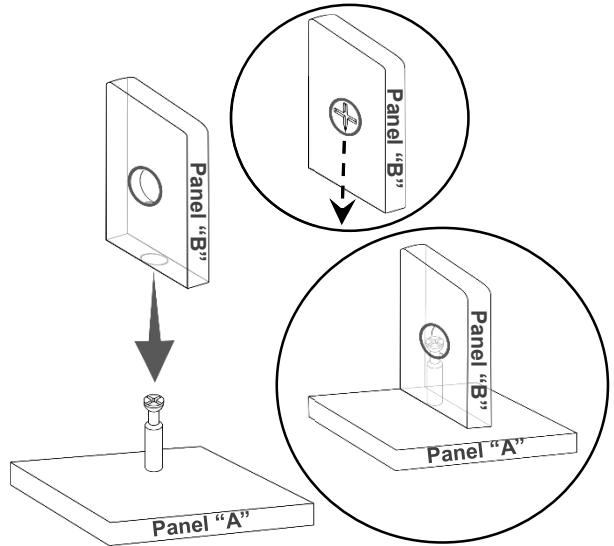

3. Insert the cam lock on panel "B" making sure it goes aligned to receive the bolt's head.

Alignment: The cross points towards the panel "A" with the bolt.

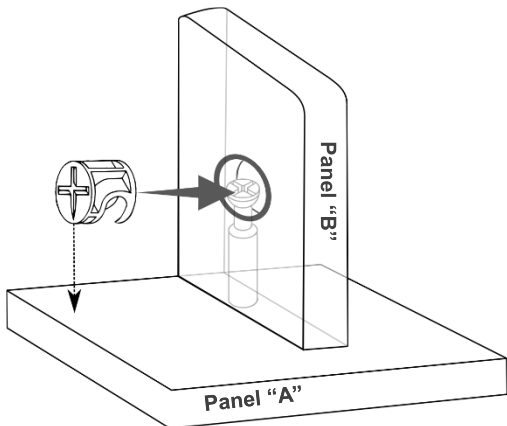

4. Turn the cam lock clockwise. This will lock the parts together and will close any gaps.

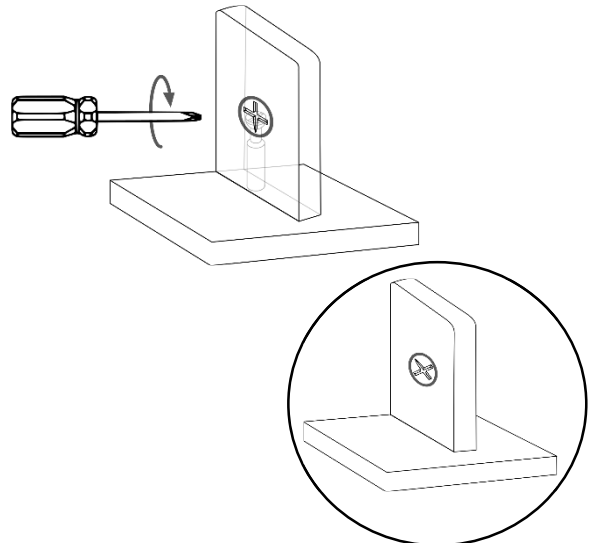

BEFORE YOU START THE ASSEMBLY, PLEASE READ THE FOLLOWING TIPS AND WARNINGS.

1 Do a quick inventory to make sure the package contains all the parts and hardware listed in the assembly instructions.



7 To avoid misalignments, always leave the screws loose and tighten them until all pieces are positioned correctly.

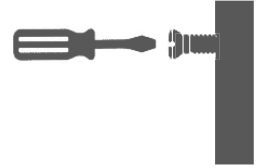

2 Missing, damaged and defective parts can be replaced at no cost to you. Please refer to the last pages on this manual.



8 Do not overtighten or force the screws as they might break, strip, damage the threads of the holes or get stuck inside the part.

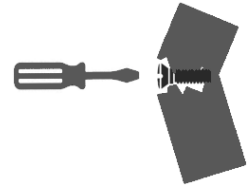

3 The replacement parts service is limited to the 48 contiguous United States. If you reside in Alaska, Hawaii, Puerto Rico, U.S. territories or other countries, please contact the supplier from where the unit was purchased.



9 Sometimes the laminate might cover partially or entirely the hole on a panel. If there is no visible hole for the screw, pass and press the tip of your finger over the area where the hole should be located to feel the indentation, and once found, carefully pierce the laminate to reveal the hole underneath.



4 If during assembly you find an issue or need clarification, please contact our Customer Service for assistance. Please refer to the last pages on this manual.



5 On each step read the instructions and analyze the illustrations thoroughly before proceeding to do the assembly.



10 If the hole seems too small for the screw, first make sure you are using the correct size of screw and that it's been installed in the correct hole. If the hole still appears to be too small, carefully pierce the laminate to reveal the hole's actual size.



6 Make sure you understand which hardware will be used on each step. Using the wrong size of screw, bolt or pin might strip the threads or cause damage to the part in which it is being used.

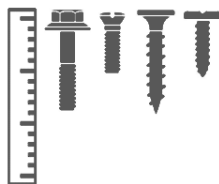

ASSEMBLY STEPS

STEP 1

Hardware:

| | | |
|----------|---|-----|
| A |  | 20 |
| | Dowels | Pcs |

| | |
|---|----------------|
|  | (NOT INCLUDED) |
|---|----------------|

| | | |
|----------|---|-----|
| F |  | 8 |
| | Bolts | Pcs |

| | |
|---|----------------|
|  | (NOT INCLUDED) |
|---|----------------|

- Insert the dowels **A** into the indicated holes on panels **2, 3, 4** and **6**.
- Attach the bolts **F** into the indicated holes on panels **2** and **4**.

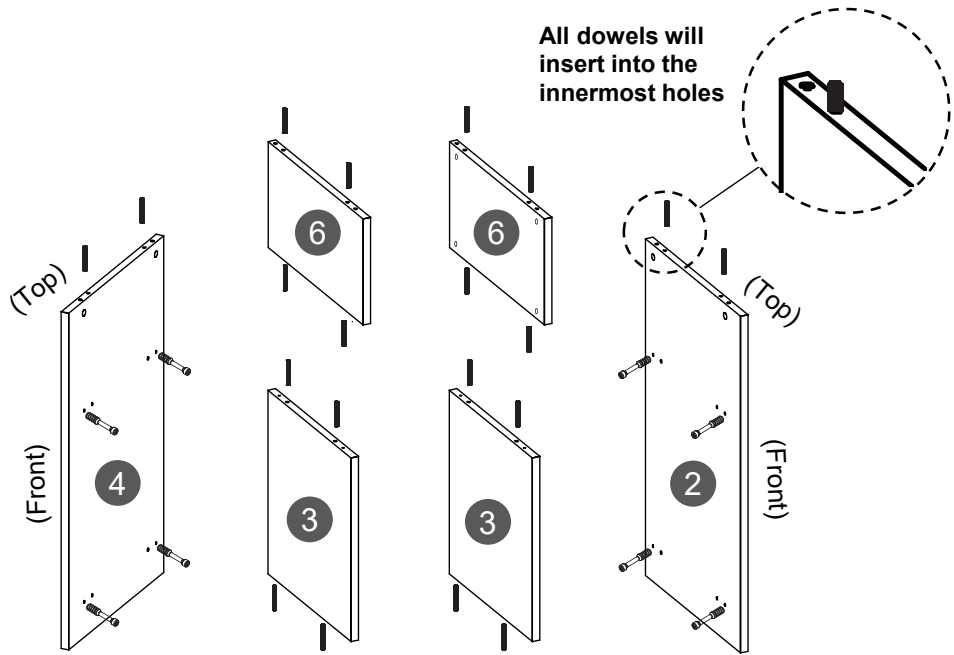

STEP 2

Hardware:

| | | |
|----------|---|-----|
| A |  | 8 |
| | Dowels | Pcs |

| | |
|---|----------------|
|  | (NOT INCLUDED) |
|---|----------------|

- Insert the dowels **A** into the innermost holes on the side edges of panels **1** and **5**.
- Insert the sliding tracks **12** into the grooves on panels **1** and **5** using a rubber mallet, but tap gently to avoid breaking them.

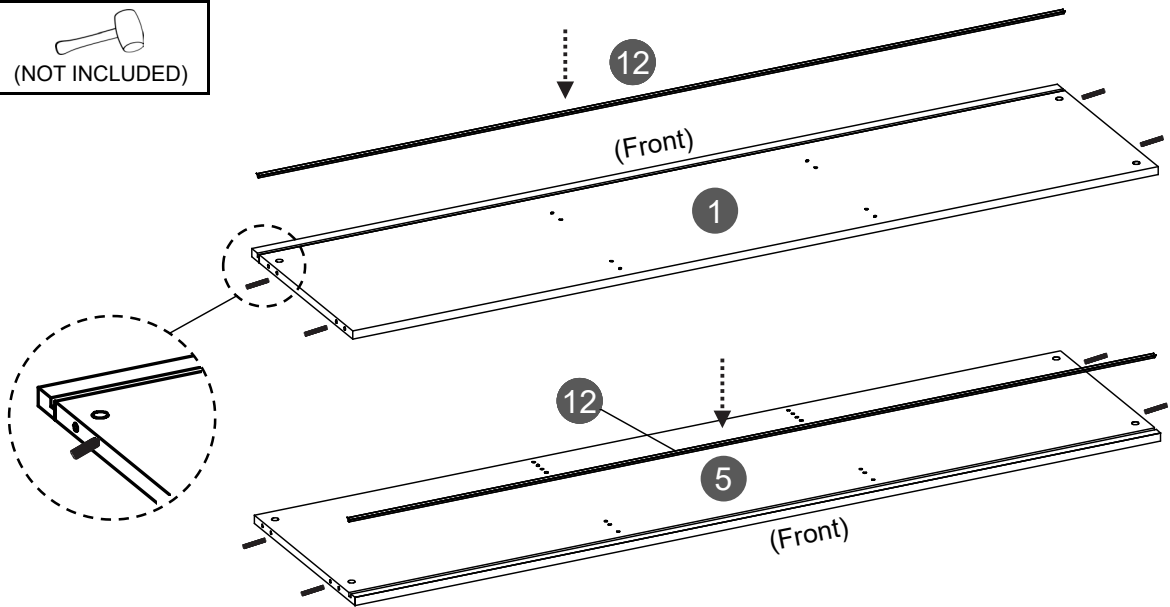

STEP 3

Hardware:

C



Cam locks

2 Pcs



- Join the left panel **4** to the bottom panel **1**.
- Insert the cam locks **C** in panel **1** and turn them to lock the panels as explained in page 4.

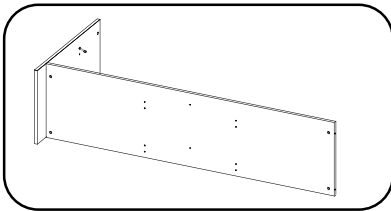
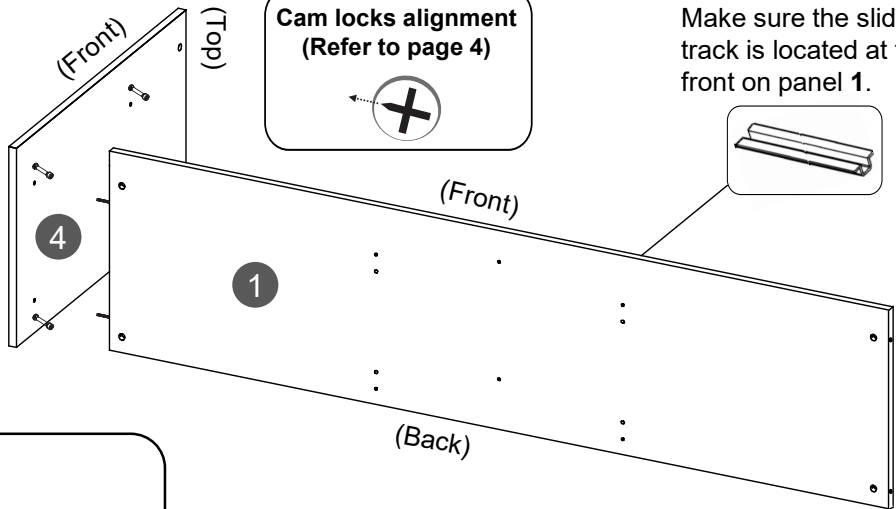

STEP 4

Hardware:

E



M3.5x40

4 Pcs



Assemble the bottom partition panels **3** to the bottom panel **1** with screws **E** from underneath.

After joined, the back of panels **3** will be flushed at the back but receded at the front

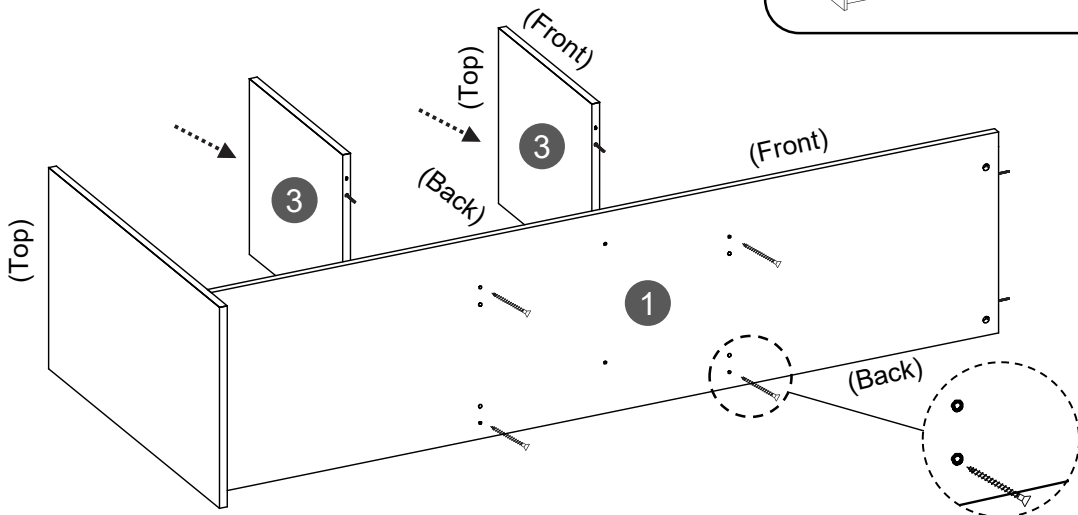
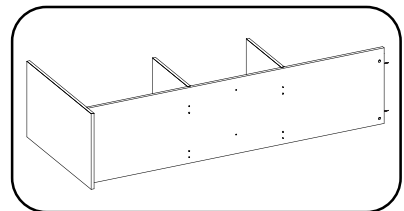

STEP 5

Hardware:

C



Cam locks

2 Pcs



(NOT INCLUDED)



With the help of another person, assemble panel 5 to panel 4 with cam locks **C** as explained in page 4. Please note that the panels 3 will also be receded from this panel.

Front holes are farther away from the edge

(Front)

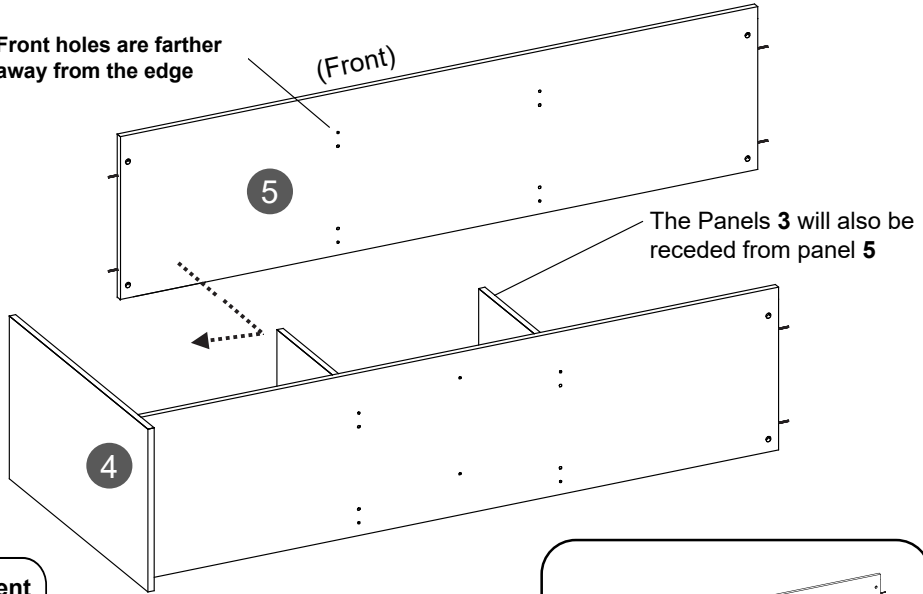

Cam locks alignment (Refer to page 4)

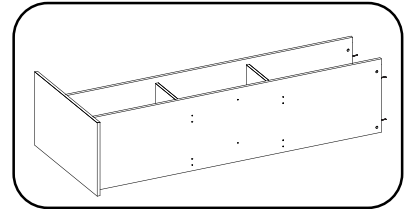

STEP 6

Hardware:

C



Cam locks

4 Pcs

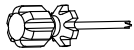

(NOT INCLUDED)

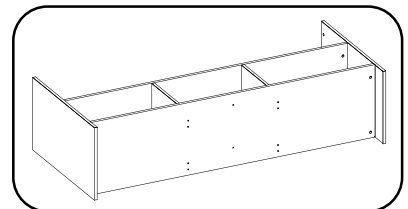
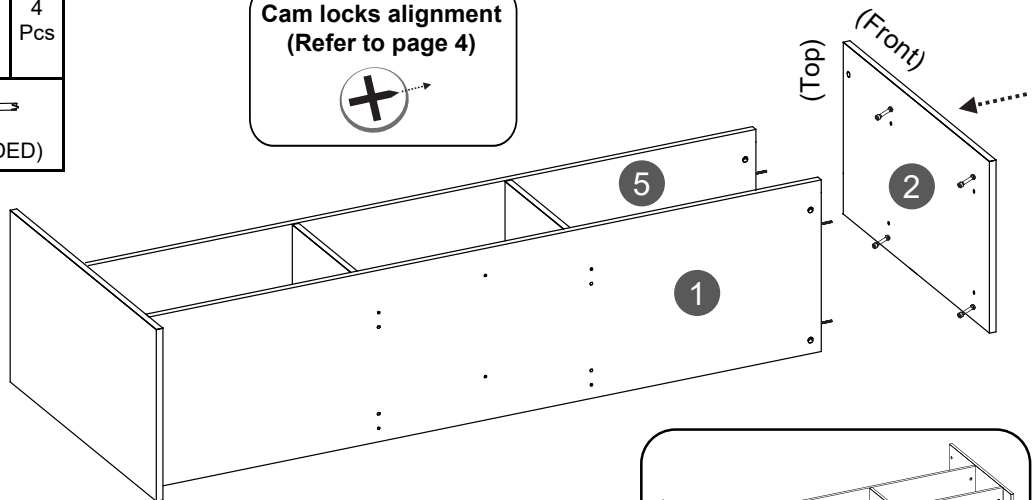

Assemble panel 2 to panels 1 and 5 with cam locks **C** as explained in page 4.

Cam locks alignment (Refer to page 4)



STEP 7

Hardware:

| | | |
|-----------------------|---|--------|
| A |  | 2 Pcs |
| Dowel | | |
| (NOT INCLUDED) | | |
| D |  | 15 Pcs |
| M3.5x12 | | |
| G |  | 15 Pcs |
| (NOT INCLUDED) | | |

- Insert dowels **A** into the indicated holes on the support panel **13**.
- Attach the brackets **G** to panels **8** and **13** with screws **D** as shown.

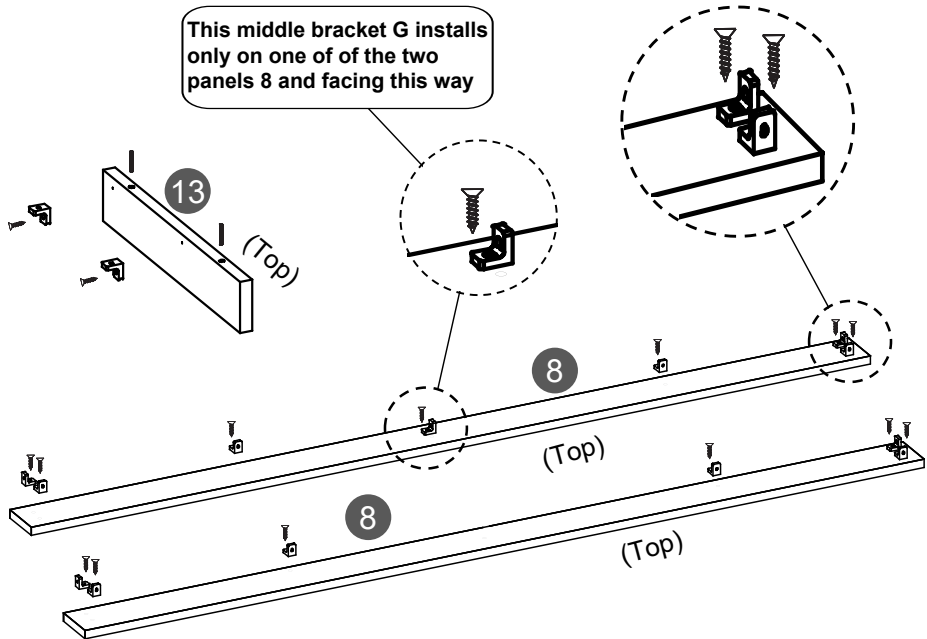

STEP 8

Hardware:

| | | |
|-----------------------|---|-------|
| D |  | 9 Pcs |
| M3.5x12 | | |
| (NOT INCLUDED) | | |

- Assemble the bottom support panel **13** to the bottom panel **1** with screws **D** through the brackets **G**.
- Assemble the front panel **8** that has the middle bracket **G** to panels **1**, **2**, **4** and **13** with screws **D** through the brackets **G**.

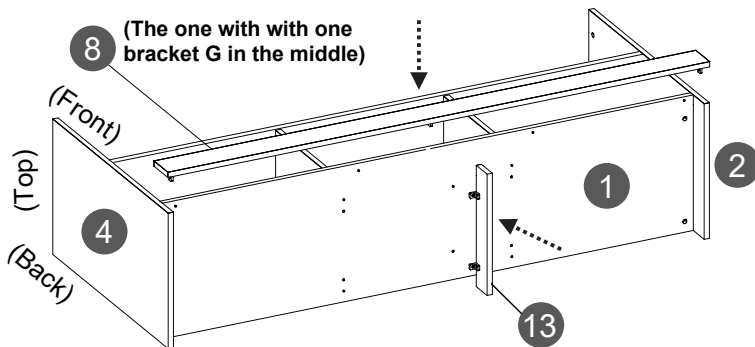

View from the bottom:

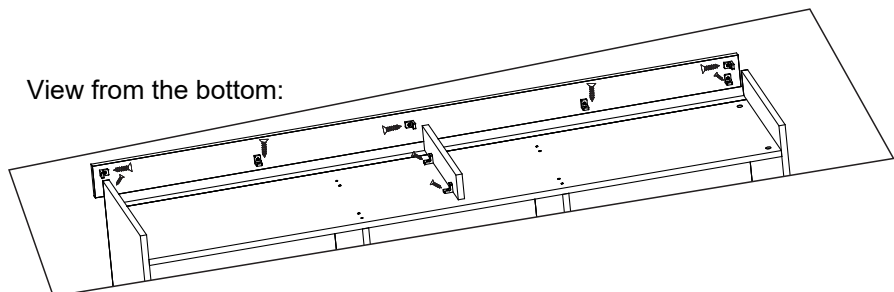

STEP 9

Hardware:

| | | |
|----------|---|----------|
| H |  | 5 Pcs |
| | Glides | |

(NOT INCLUDED)



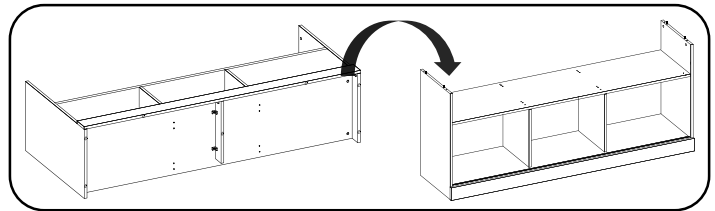
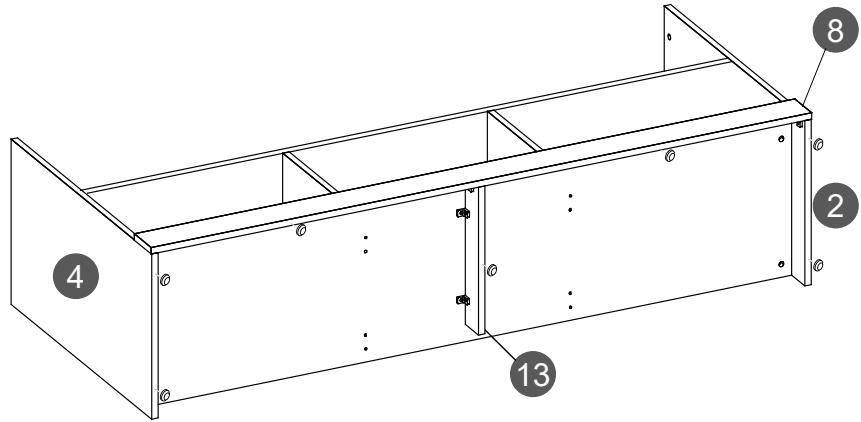

- Attach the glide studs **H** on the bottom of panels **2**, **4** and **13**.
- With the help of another person, bring the unit upright.



STEP 10

Hardware:

| | | |
|----------|---|----------|
| E |  | 4 Pcs |
| | M3.5x40 | |

| | | |
|----------|---|----------|
| B |  | 4 Pcs |
| | M5x31 Bolts | |

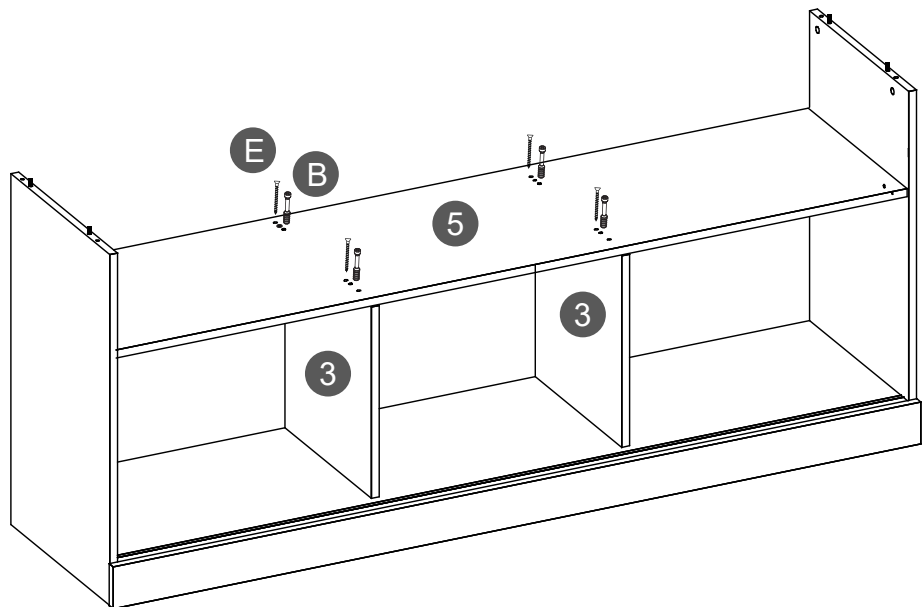

(NOT INCLUDED)

- Secure panel **5** to panels **3** with screws **E** through the indicated holes.
- Attach the bolts **B** to panel **5** in the indicated holes.

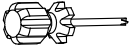

STEP 11

Hardware:

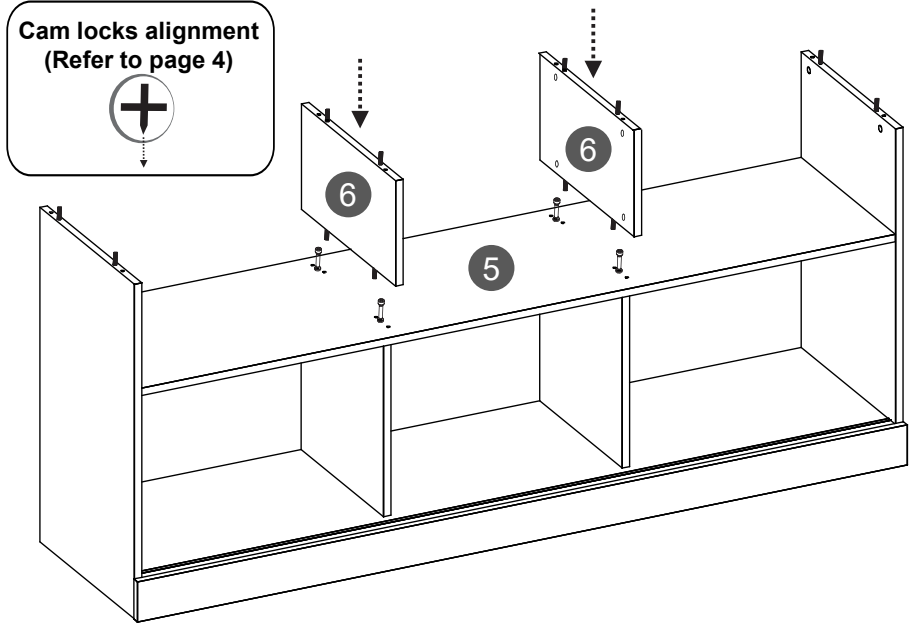

| | | |
|---|---|-----|
| B |  | 4 |
| | Cam locks | Pcs |
|  | | |
| (NOT INCLUDED) | | |

Assemble the top partition panels **6** to panel **5** with cam locks **B** as explained in page 4.





STEP 12

Hardware:

| | | |
|----------|---|-----|
| D |  | 4 |
| | M3.25x12 | Pcs |
| B |  | 8 |
| | M5x31 Bolts | Pcs |

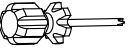
- With the help of another person (to ensure a good alignment of the pieces), assemble the other front panel **8** to the top panel **7** with screws **D** through the brackets **G**.
- Attach the bolts **B** to panel **7** in the indicated holes.



(NOT INCLUDED)

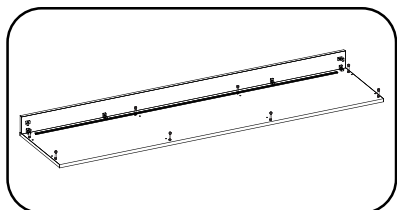
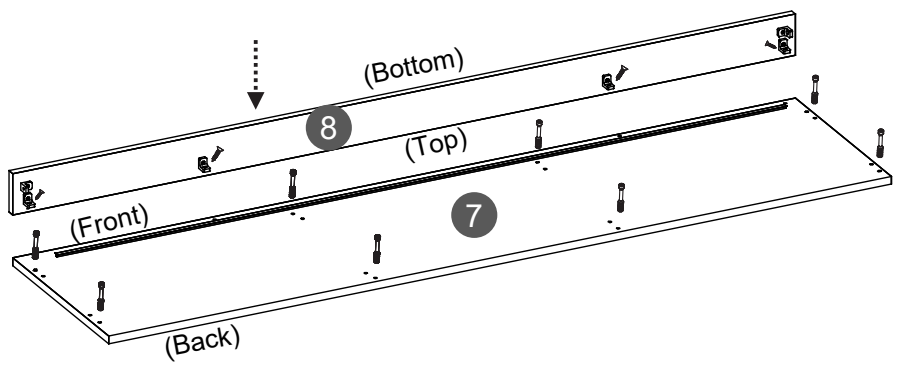





STEP 13

Hardware:

| | | |
|----------|---|-------|
| D |  | 2 Pcs |
| | M3.5x12 | |
| B |  | 8 Pcs |
| | Cam locks | |



(NOT INCLUDED)



Cam locks alignment
(Refer to page 4)



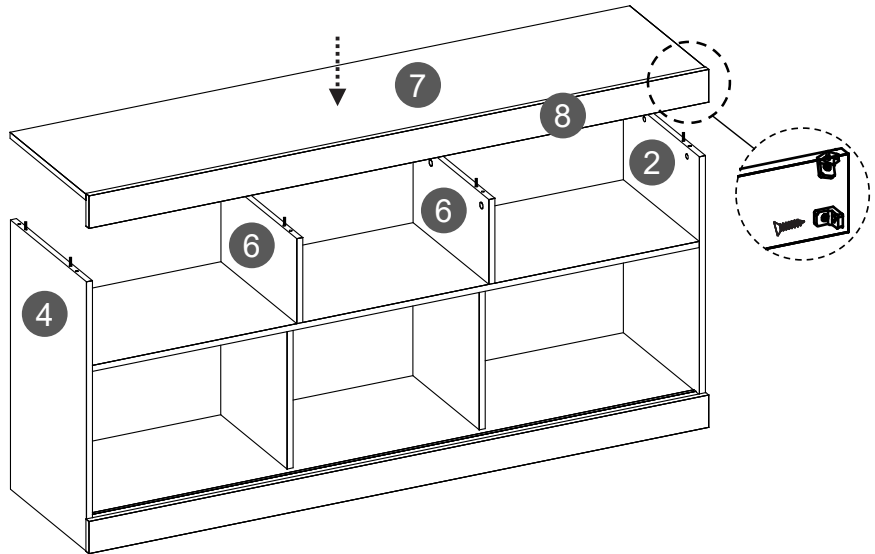



- With the help of another person, assemble the top panel **7** to panels **2**, **4** and **6** with cam locks **B** as explained in page 4.
- Secure the front panel **8** to the side panels **2** and **4** with screws **D** through the brackets **G**.

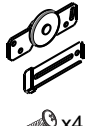

STEP 14

Hardware:

| | | |
|----------|---|--------|
| F |  | 2 Pcs |
| | M3.5x25 | |
| J |  | 1 Pc |
| | Handle | |
| K |  | 2 sets |
| | x4 | |

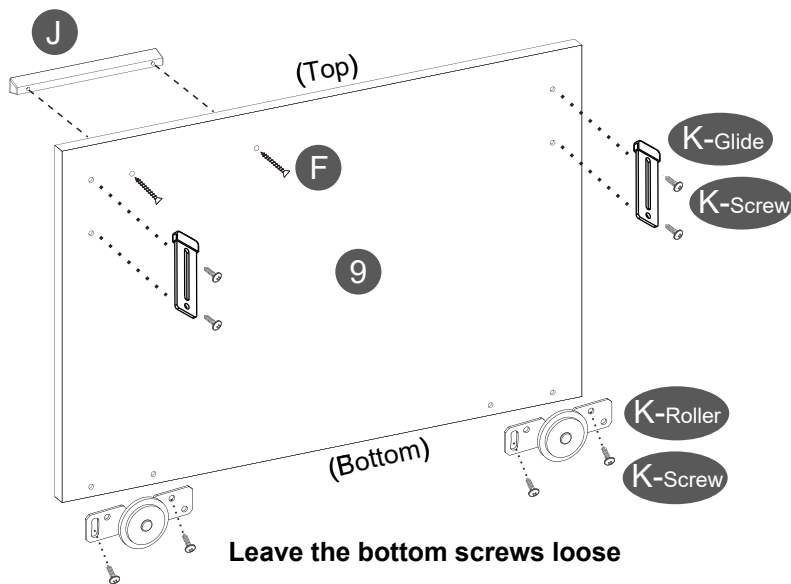

(NOT INCLUDED)

- Assemble the handle **J** to the front face of the door **9** with screws **F**.
- Attach the top **glides K** to the top holes on the other side of the door **9** using the own screws that come in the set **K**.
- Attach the bottom **rollers K** to the bottom holes with own screws, but **leave them loose** to allow the roller to pivot and make possible to install the door into the unit in the next step.

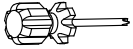

STEP 15

Hardware:



(NOT INCLUDED)

- Insert the door **9** into the unit by engaging first the top glides **K** into the top sliding track **12**, then engage the bottom rollers **K** into the bottom sliding track **12**.
- Secure the bottom rollers **K** to the door **9** by tightening the screws from inside the unit.

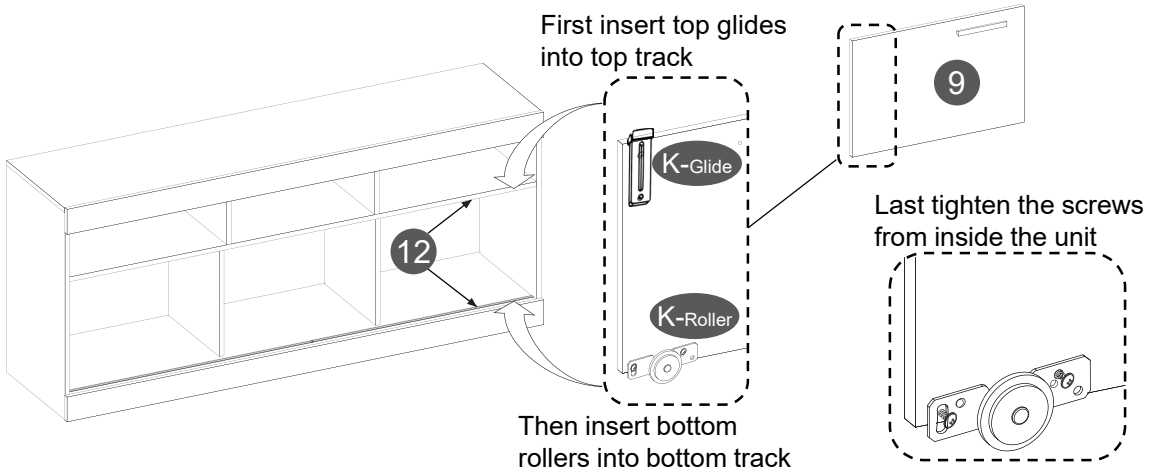

STEP 16

Hardware:

| | | |
|---|-----------------|--------------|
| L | | 12 to 50 Pcs |
| | Junction plates | |

| | | |
|---|-------|-------------|
| M | | 4 to 10 Pcs |
| | Nails | |

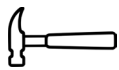

(NOT INCLUDED)



With the help of another person, use a minimum of 12 nails **M** and a minimum of 4 junction plates **L** to attach the bottom back panel **10** and the top back panel **11** to the back side of the unit.

Important:

- The panels don't cover the back completely, so make sure to align and center with all sides.
- Use the plates **L** in between the two panels only.
- Center the nails on the panels, if they go too close to the edge of the panel, it could split the wood.
- Make sure the nails enter as straight as possible into the panels. If they go slanted they could split the wood.

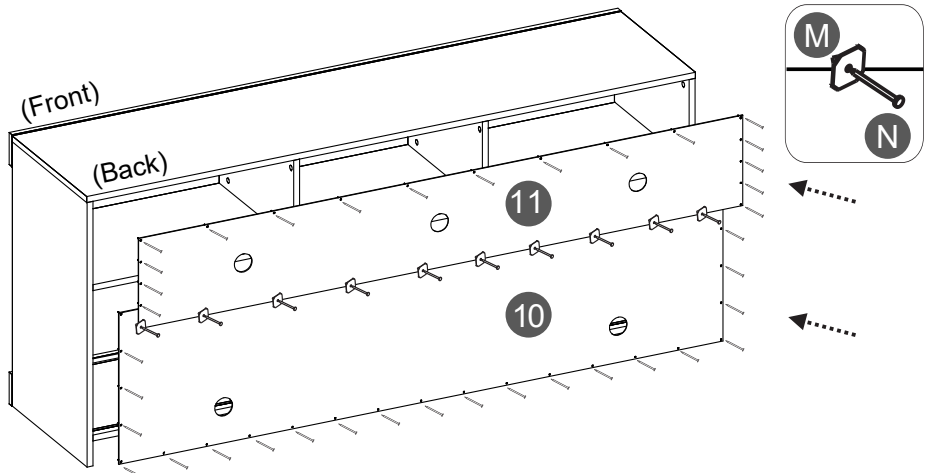

STEP 17

Hardware:

| | | |
|---|---|-----------|
| I |  Covers | 12 Pcs |
| N | Touch-Up | 1 Pc |

- Attach the stickers I to cover the cam locks.
- If needed, use the touch-up chalk N to fix any small damages or imperfections on the finish.

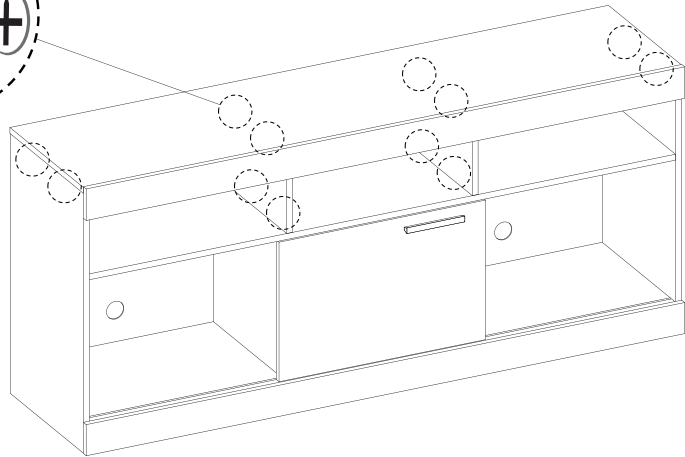
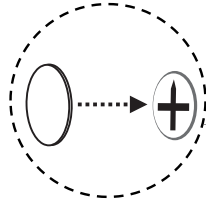

ALL DONE!

Give yourself a nice pat on the back. You did a great job!

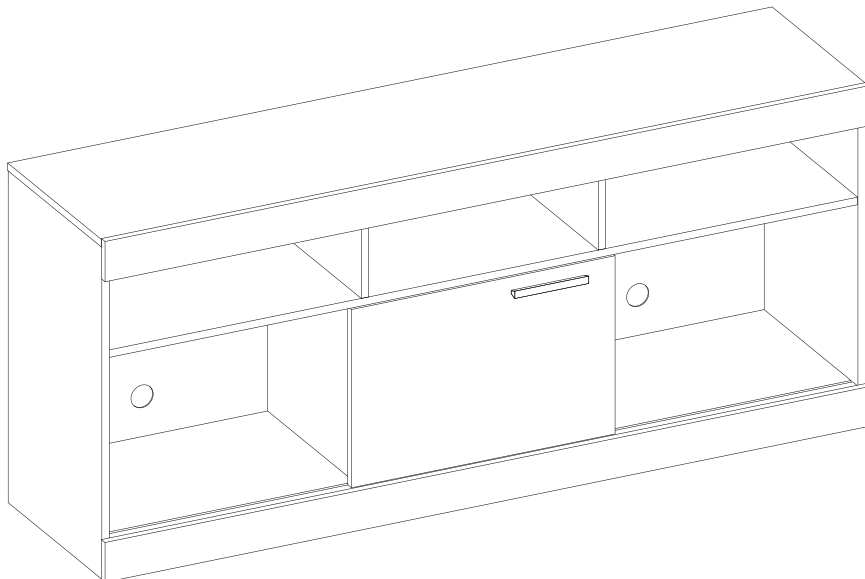

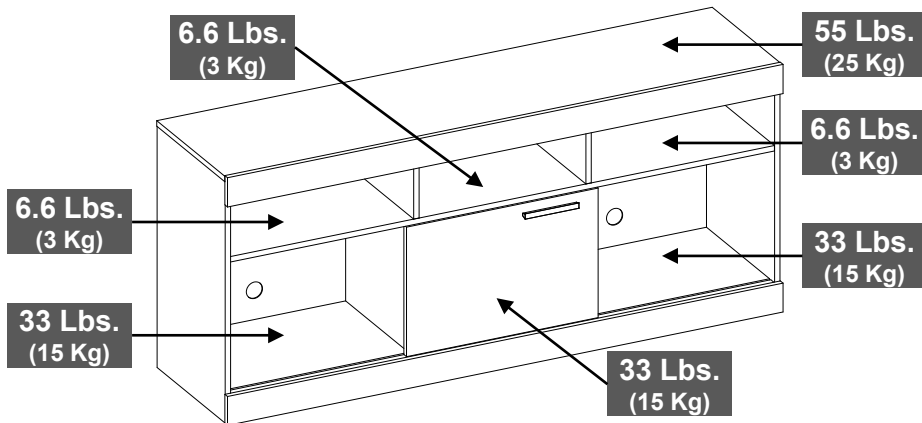
CARE, MAINTENANCE AND SAFETY WARNINGS:**WEIGHT LIMITS**

- Do not exceed the indicated weight limits.
- Do not expose the surfaces to direct sunlight or to extreme environmental conditions.
- Clean the surfaces preferable with a clean cloth damped in a solution of mild soap and water, then dry with a clean towel.
- Do not use solvents or abrasive materials to clean the unit.
- If you decide to use a cleaning agent, test first on an area hidden from view such as underneath the top panel.
- Do not sit on the unit or step on it to use it as a step ladder.
- Do not allow small children to play inside the compartments or climb on the unit as your TV set might tip over and fall on them causing serious injuries.
- Do not pull, push or drag the unit to move it for more than 1 feet. The unit must be lifted by at least 2 persons when moving in the same or adjacent rooms.
- Before moving the unit, make sure to secure or remove your TV set or any other objects that are heavy or might fall off. Please note that lifting from the top panel with too much weight on the product might lead to part damage/separation.
- When lifting the unit, use both hands and bend your knees, not your backs.
- When transporting the unit to places far away, protect and secure the unit to avoid damage in transit.
- Shall any part of the unit become defective during the warranty period, replacement parts might be available to you at no charge. Please refer to the last pages on this manual.
- The warranty does not extend to regular wear and tear, nor the manufacturer assumes liability for damages or consequences due to accidents, incorrect assembly, negligence, improper use, modifications, or not heeding the above warnings.

DESKS/LAPTOP CARTS/FILE CABINETS: LIMITED 5-YEAR WARRANTY

RTA Products, LLC warrants to the Original Purchaser who acquired a new product from RTA Products or its authorized resellers that this product will be free from defects in its workmanship and materials, under normal use and service conditions, as described herein. "Defects" as used in this warranty, is defined as any imperfections that impair the use of the furniture or product. RTA Products LLC will replace any defective part, at its discretion, and without charge to the original purchaser other than the freight from the end consumer to RTA Products.

Replacement parts can only be supplied if parts are available. Items out of production may be unavailable. This warranty will be effective for the applicable time period beginning the date of purchase on your original sales receipt. RTA product's obligation under this warranty is limited to repairing or replacing products or parts as provided herein. This product has been designed for and is intended for office and home-office use only. This warranty is Original Purchaser's sole remedy for product defects, and this warranty does not extend to any product, or damage to any product, caused by or attributed to abuse or misuse, products used for commercial or rental purposes, use modifications of, or attachments to the product, and products or parts not used, maintained, or extended hereunder is in lieu of any and all other warranties, express or implied, including without limitations any implied warranty or merchantability or of fitness for a particular purpose. Please note, all desks made with PVC Laminate surface should not be exposed to direct sunlight, as it may damage the material. Damage of this nature is not covered under this warranty.

RTA Products will not be responsible for indirect, special, incidental or consequential damages. This warranty is limited to merchandise purchased in the Continental United States, excludes AK, HI and PR. Some States do not allow the exclusion or limitation of incidental or consequential damages, so the above limitations or exclusions may not apply to you. This warranty gives you specific legal rights. You may also have other rights that may vary from state to state.