

CY-25001 DINING CHAIR

Product ID. QUTBI







Scan for Support
support@garvee.com





Distributed by
GARVEE.com

V251120DVA1

ASSEMBLY INSTRUCTION

HARDWARE LIST	CODE	PARTS	QTY .
	A	M8x55MM 	5+1 extra
	B	M8x80MM 	4+1 extra
	C	M8x22x1.5MM 	9+1 extra
D	ALLEN KEY 	1	

COMPONENT LIST	E BACK	F SEAT	G LEGS
	 X1	 X1	 X2

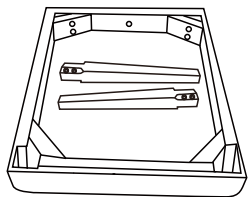

Open the black dust cover and take out the legs.

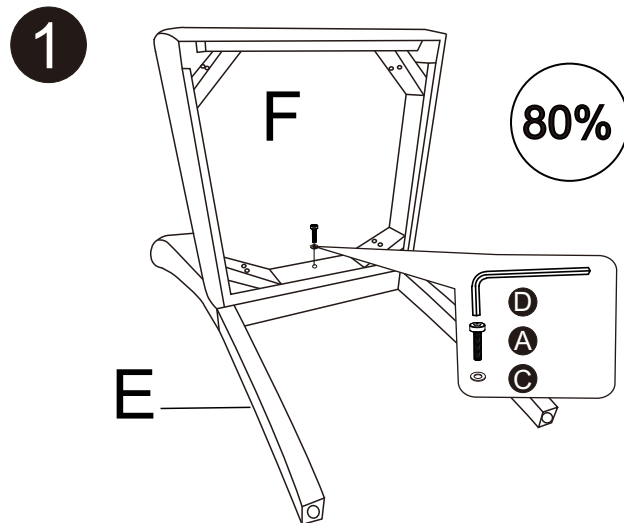

Note:
Screwing **A** on the chair (tighten 80% of screws first), it might help you assemble more easily.

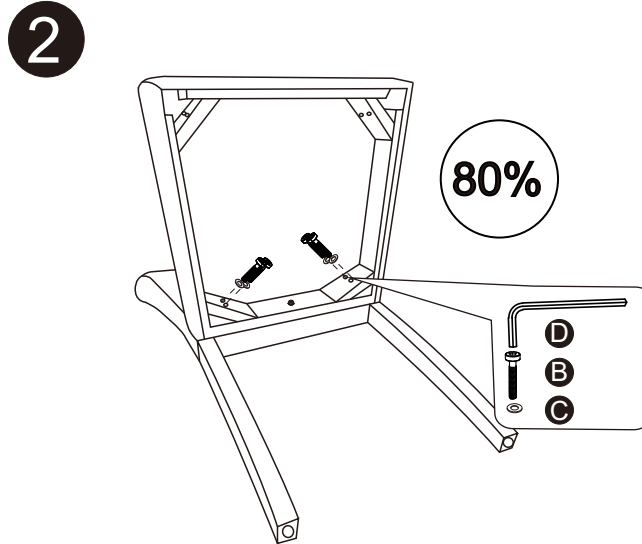

Note:
Screwing **B** on the chair (tighten 80% of screws first), it might help you assemble more easily.

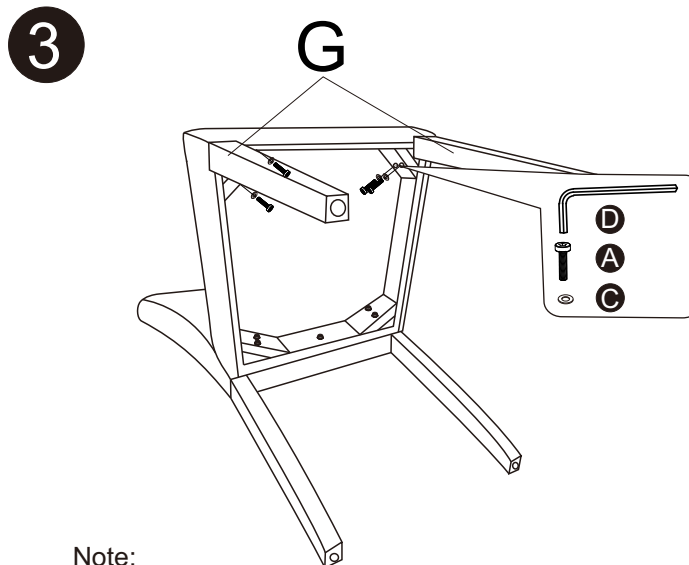

Note:
Screwing **A** on the chair (tighten 80% of screws first), it might help you assemble more easily.

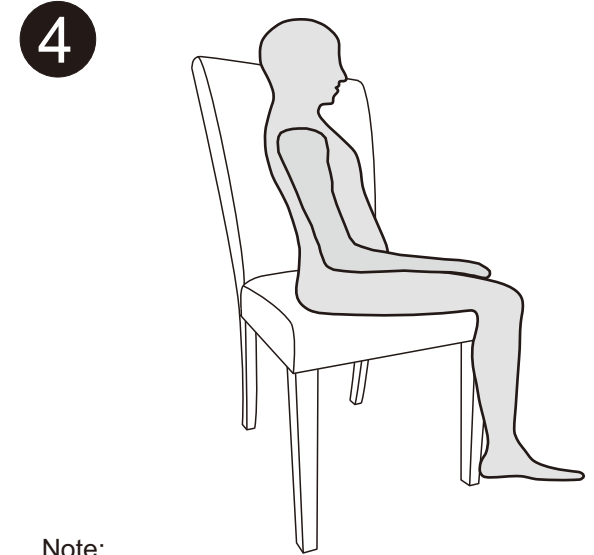

Note:
Ensure the chair is stable on the ground and doesn't require any adjustments, then tighten all screws to 100%.

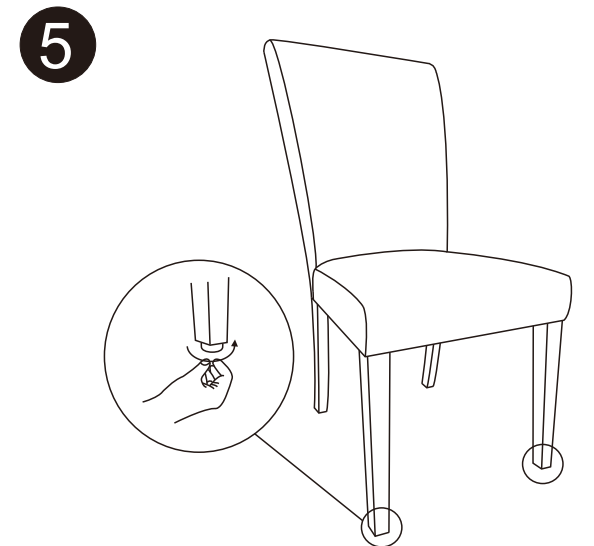

Limited Liability & Warning

No Unauthorized Modifications/Repairs: Do not modify or attempt to repair this product unless you are an authorized technician. Unauthorized actions may create hazards and void all warranties

Misuse & Non-Compliance: We are not liable for any injury, damage, or loss resulting from:

- (a) misuse, abuse, neglect, or improper installation;
- (b) failure to follow instructions or safety precautions;
- (c) use of unauthorized parts/accessories;
- (d) unauthorized modifications/repairs;
- (e) accidents, natural disasters, or external causes.

If you doubt any step of installation or operation, stop using the product and contact authorized service or the customer support.

LIMITACIÓN DE RESPONSABILIDAD Y ADVERTENCIA

Modificaciones o Reparaciones No Autorizadas: NO modifique ni intente reparar este producto a menos que sea un técnico autorizado. Las acciones no autorizadas pueden generar riesgos y anularán todas las garantías.

Uso Indebido e Incumplimiento: No asumimos responsabilidad alguna por lesiones, daños o pérdidas que resulten de:

- (a) uso indebido, abuso, negligencia o instalación incorrecta;
- (b) incumplimiento de las instrucciones o precauciones de seguridad;
- (c) uso de piezas o accesorios no autorizados;
- (d) modificaciones o reparaciones no autorizadas;
- (e) accidentes, desastres naturales o causas externas.

Si tiene dudas sobre algún paso de la instalación o el funcionamiento, deje de usar el producto y póngase en contacto con el servicio técnico autorizado o con atención al cliente.

GARVEE

support@garvee.com