

L-shaped Desk

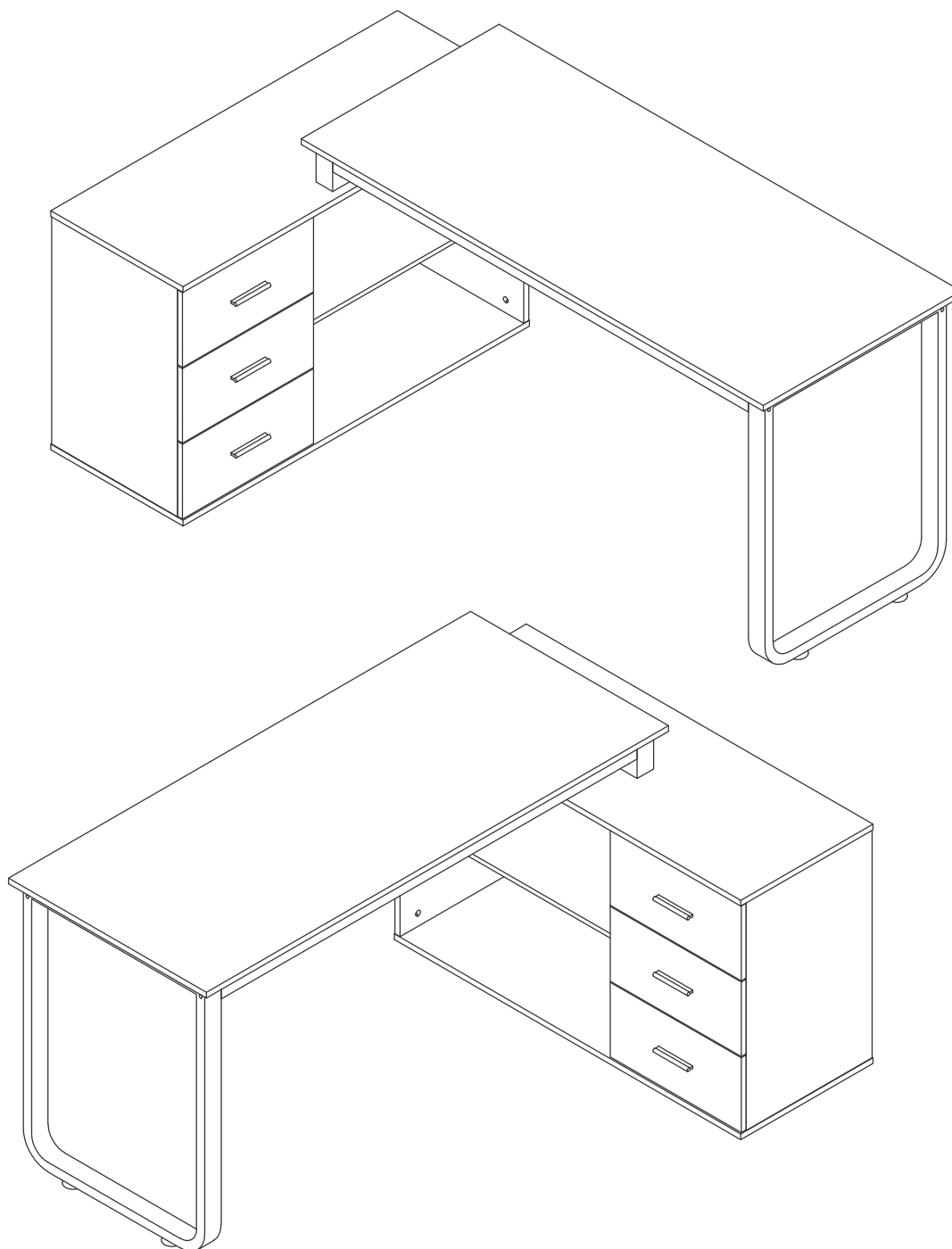

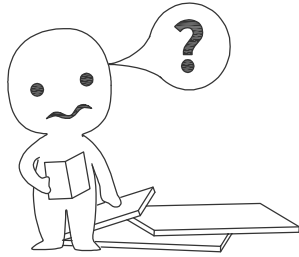

IMPORTANT INFORMATION!

please read the entire manual before starting to assemble and/or using this product. follow the manual thoroughly and keep it for further reference.

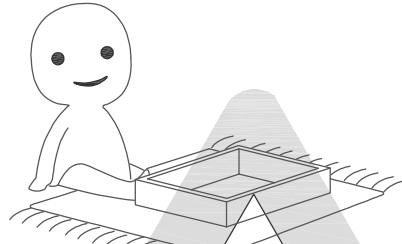
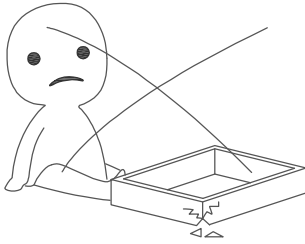

AVOID SCRATCHES!

In order to avoid scratching this furniture should be assembled on a soft layer—could be a rug.

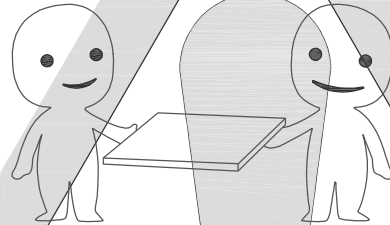
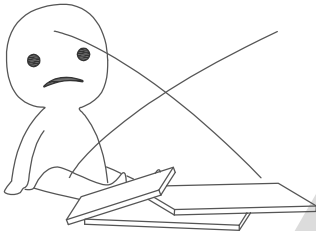

IMPROVE EFFICIENCY !

Try to find a partner to install with you, which can speed up the installation efficiency and shorten the time.

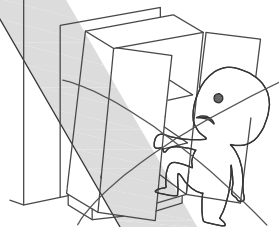
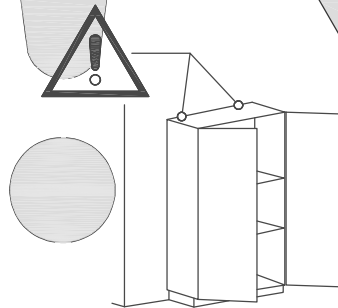
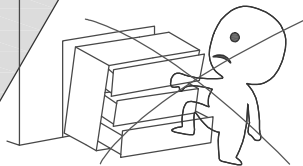
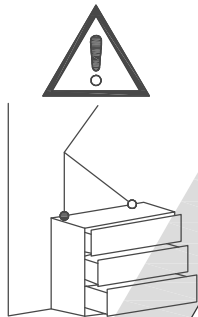

ANTI-TOPPLE WARNING !

Overturned furniture can cause serious or fatal crush injuries. To prevent tipping over, be sure to use the wall attachment, if not included with this product. Please purchase the wall attachment that fit your wall. If unsure, seek professional advice. Please read and follow each step of the instructions carefully.

IMPORTANT !

It is important that any product which is assembled using any kind of screw is re-tightened 2 weeks after assembly, and once every 3 months - in order to assure stability through-out the lifespan of the product.

For regular maintenance and cleaning of the product, for the frame, please use a rag dipped in neutral detergent to fully wipe it, and then dry it with a clean rag. For glass materials, wipe with a rag dampened with water glass cleaner, and then dry with a dry rag.



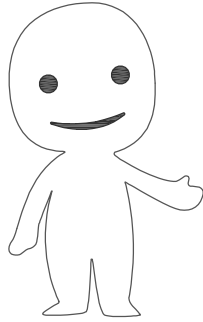



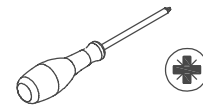
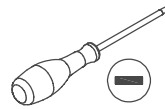
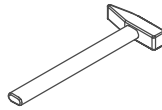



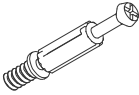

Do not use an electric screwdriver, and do not use too much force when installing, because the board is easy to break.

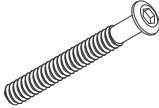
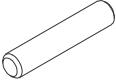

Please prepare the following tools

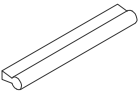

When installing, please carefully confirm whether each screw corresponds to the manual, accessories with similar shapes can be distinguished by size

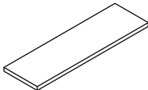
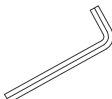
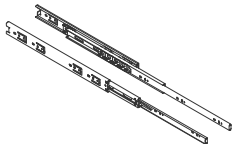
<p>A x 28</p>  <p>M5 x 45 mm</p>	<p>B x 28</p>  <p>Ø15 x 10 mm</p>	<p>C x 24</p>  <p>M3.5 x 12 mm</p>	<p>D x 12</p>  <p>M5 x 40 mm</p>
<p>E x 4</p>  <p>M6 x 35 mm</p>	<p>F x 4</p>  <p>M6 x 60 mm</p>	<p>G x 4</p>  <p>M6 x 70 mm</p>	<p>H x 14</p>  <p>Ø8 x 40 mm</p>
<p>I x 4</p>  <p>Ø6 mm</p>	<p>J x 6</p>  <p>M4 x 18 mm</p>	<p>K x 2</p>  <p>M8</p>	<p>L x 3</p> 
<p>M x 6</p>  <p>Ø30 x 3 mm</p>	<p>N x 1</p>  <p>540 x 40 mm</p>	<p>O x 1</p>  <p>4 #</p>	<p>17</p>  <p>14"(3508W) 3 SET</p>

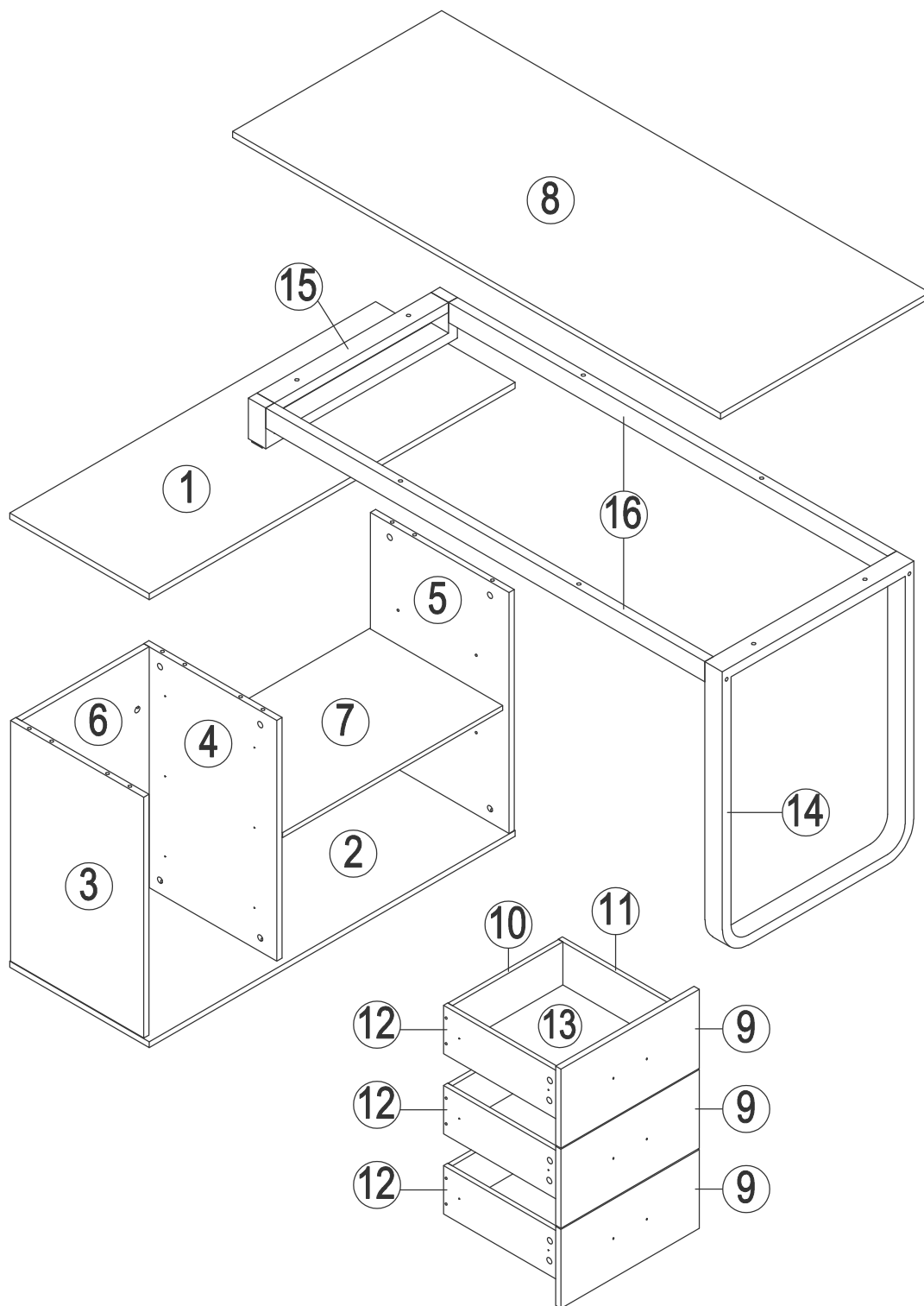

**Slides Must Be Separated Before Assembly.
After Separated, Set Aside Until Needed for Assembly.**

Las diapositivas deben separarse antes del montaje.
Después de la separación, déjelo a un lado hasta que sea necesario.

Les glissières doivent être séparées avant l'assemblage.
Après la séparation, mettez de côté jusqu'au moment de l'assemblage.

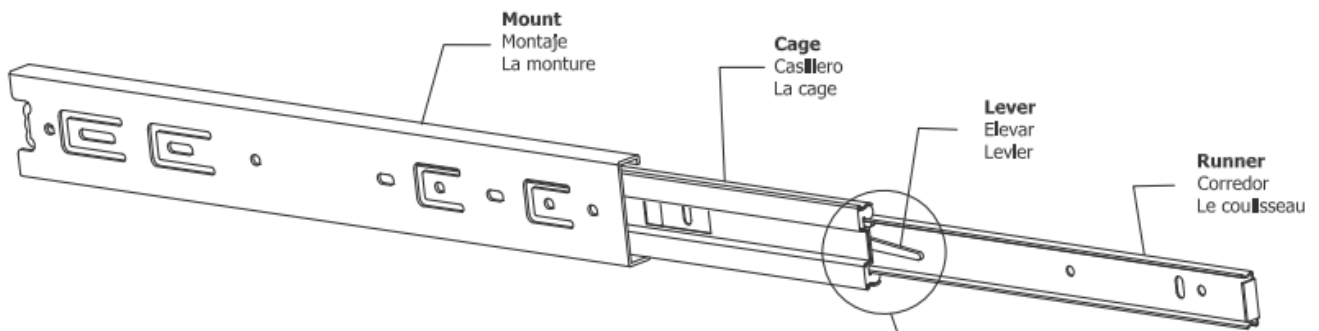

STEP 1: Extend Slide
Extender la diapositiva
Extendre la diapositive

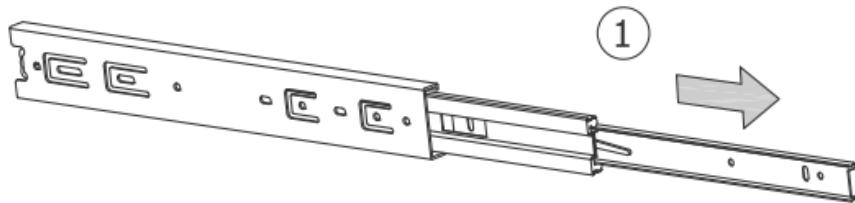

STEP 2: Push Lever UP
Empujar hacia arriba
Lever le levier

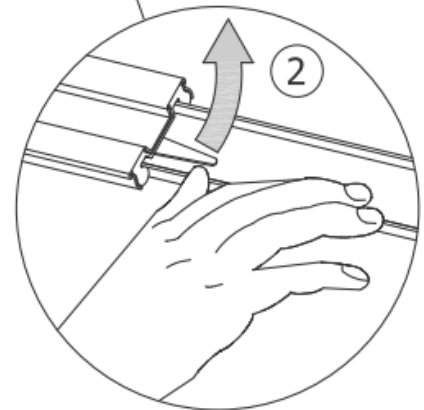

STEP 3: Remove Runner
Quitar el corredor
Enlever le coureur

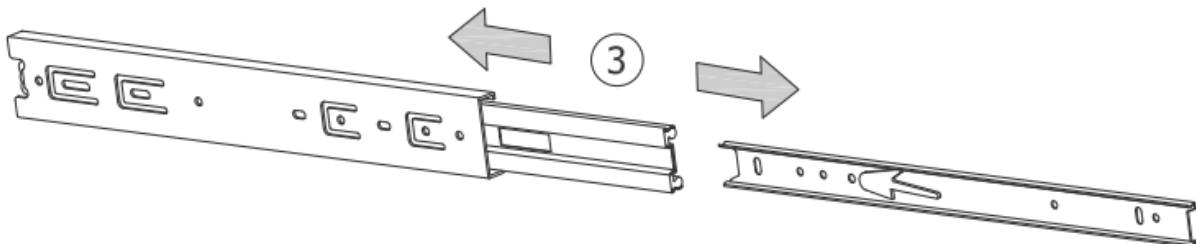

1

K x 2



M8

Rotate part(K) into the bottom of leg 14 as shown.

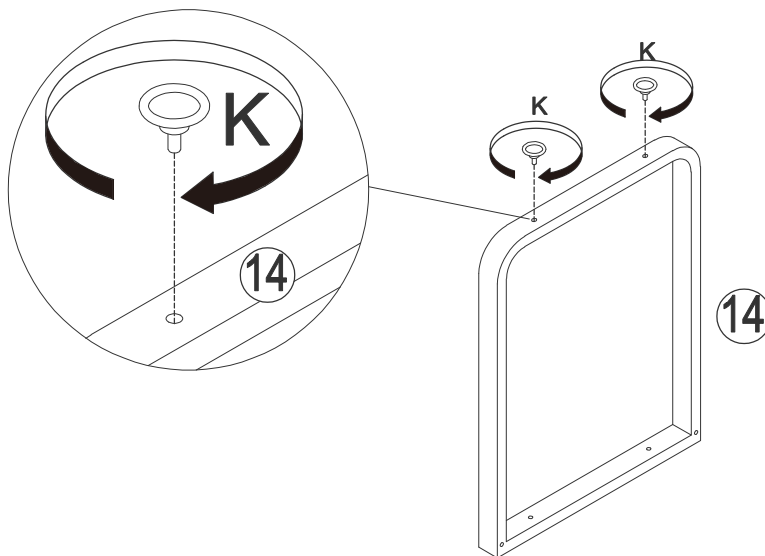

2

G x 4



M6x70MM

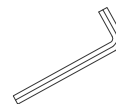

Attach leg 14 and part 15 to bar 16 with screw(G) as shown.

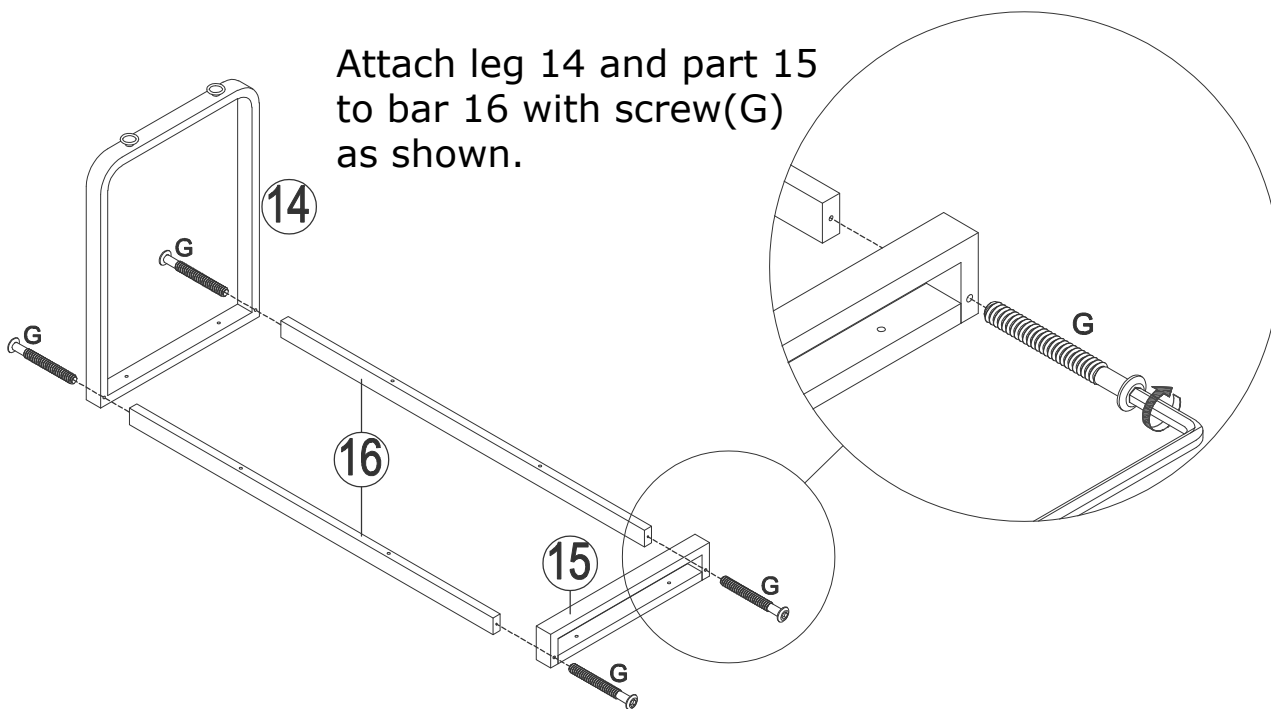

3

E x 4



M6x35MM

F x 4



M6x60MM

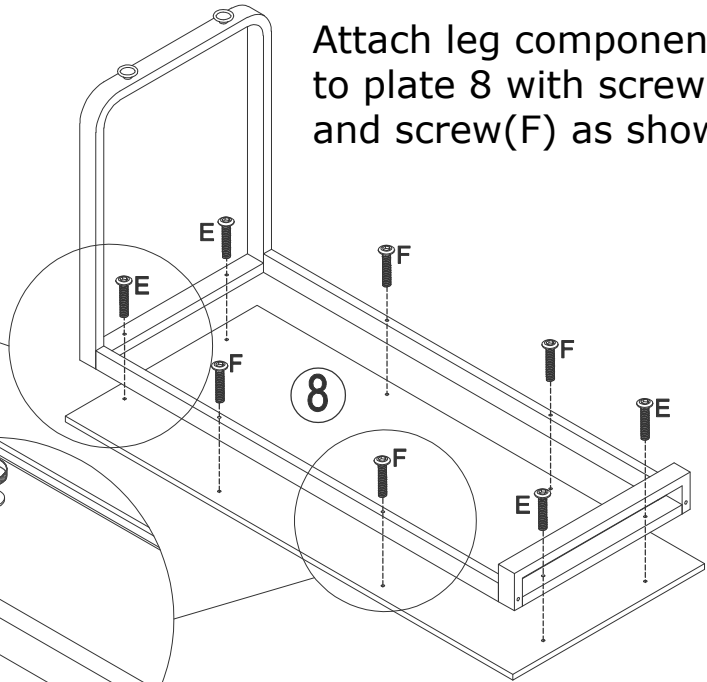
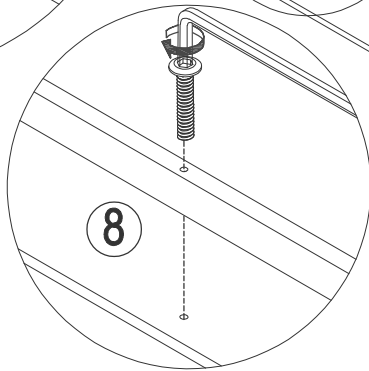
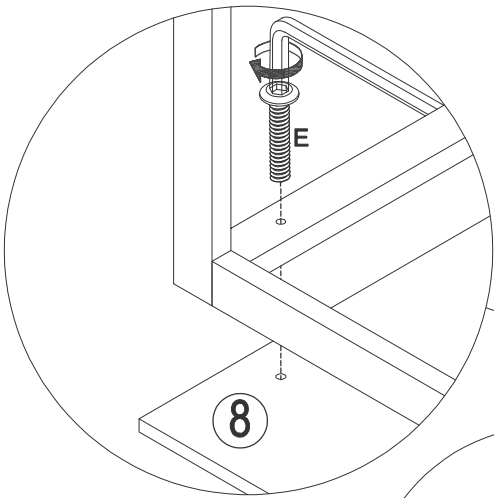
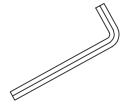

Attach leg component to plate 8 with screw(E) and screw(F) as shown.

4

N x 1

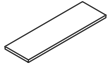

540x40MM

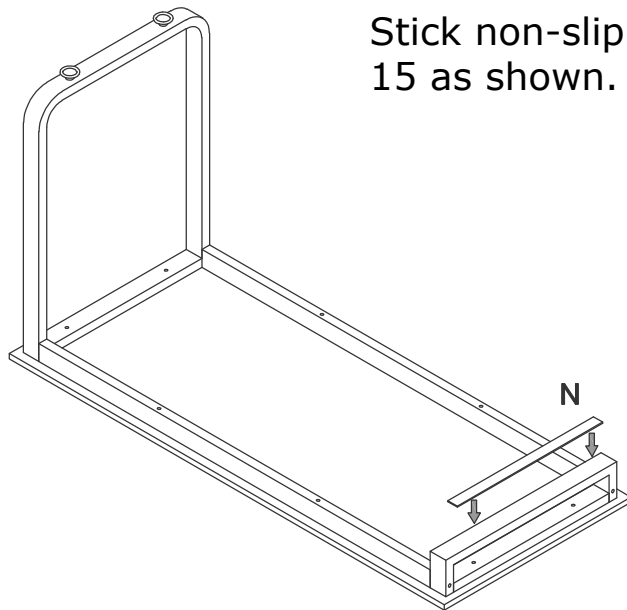

Stick non-slip mat(N) to part 15 as shown.

5

C x 6



M3.5x12MM

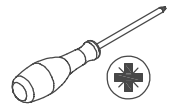

Back section of part

17

17

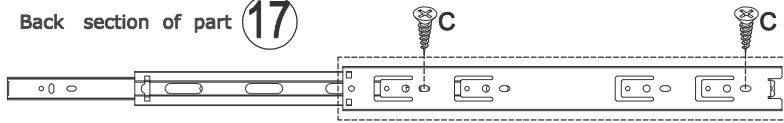

Separate glides. Fix slide rail 17 to plate 3 with screw(C) as shown.

Please pay attention to the holes where the accessories are inserted.

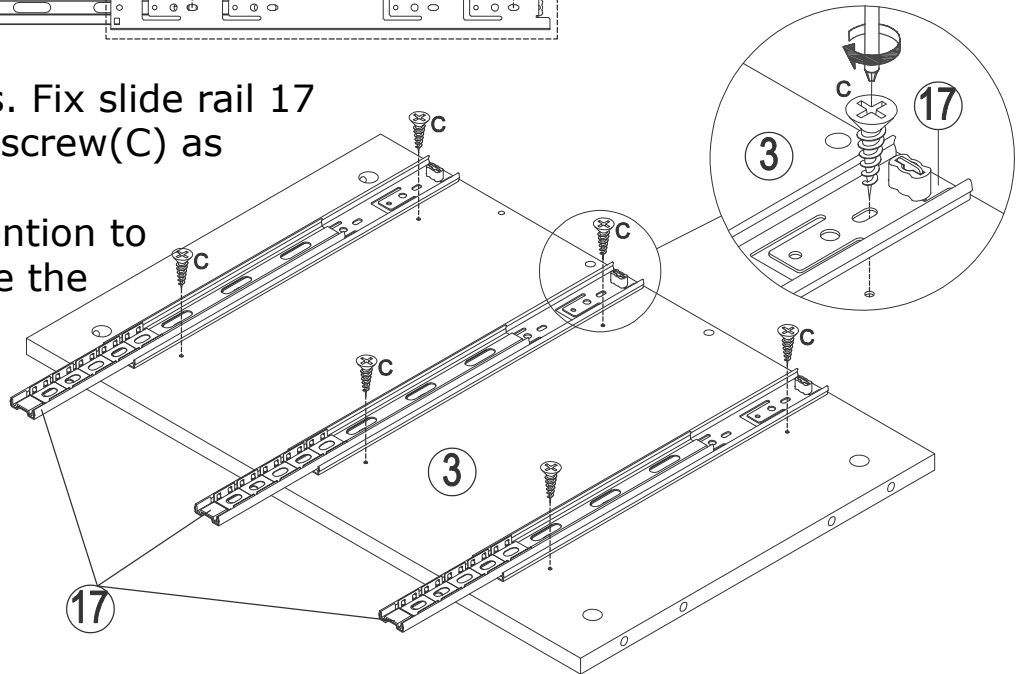

6

A x 2

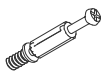

M5x45MM

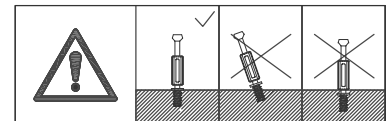
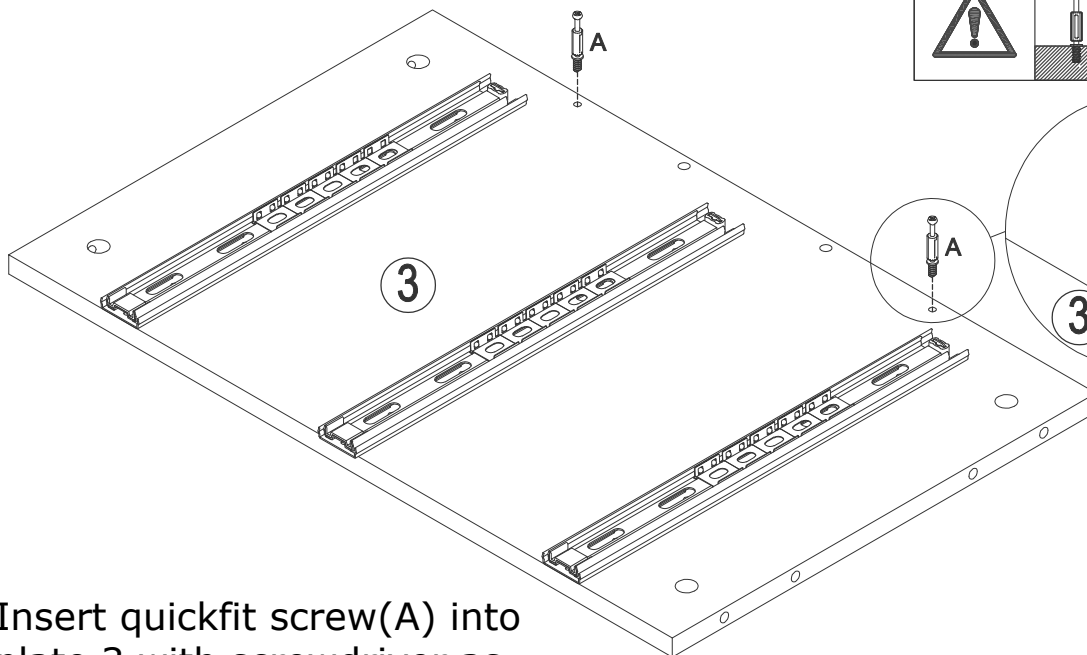
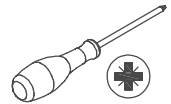

Insert quickfit screw(A) into plate 3 with screwdriver as shown.

7

C x 6



M3.5x12MM

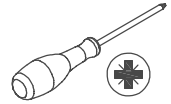

Back section of part 17

17

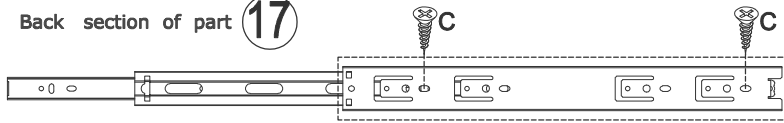

Fix slide rail 17 to plate 4 with screw(C) as shown. Please pay attention to the holes where the accessories are inserted.

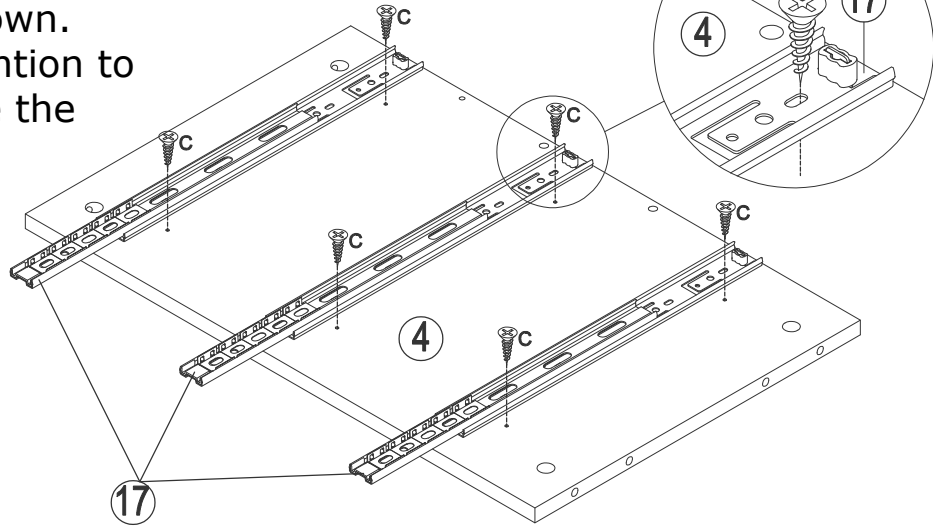

8

A x 2

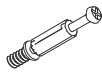

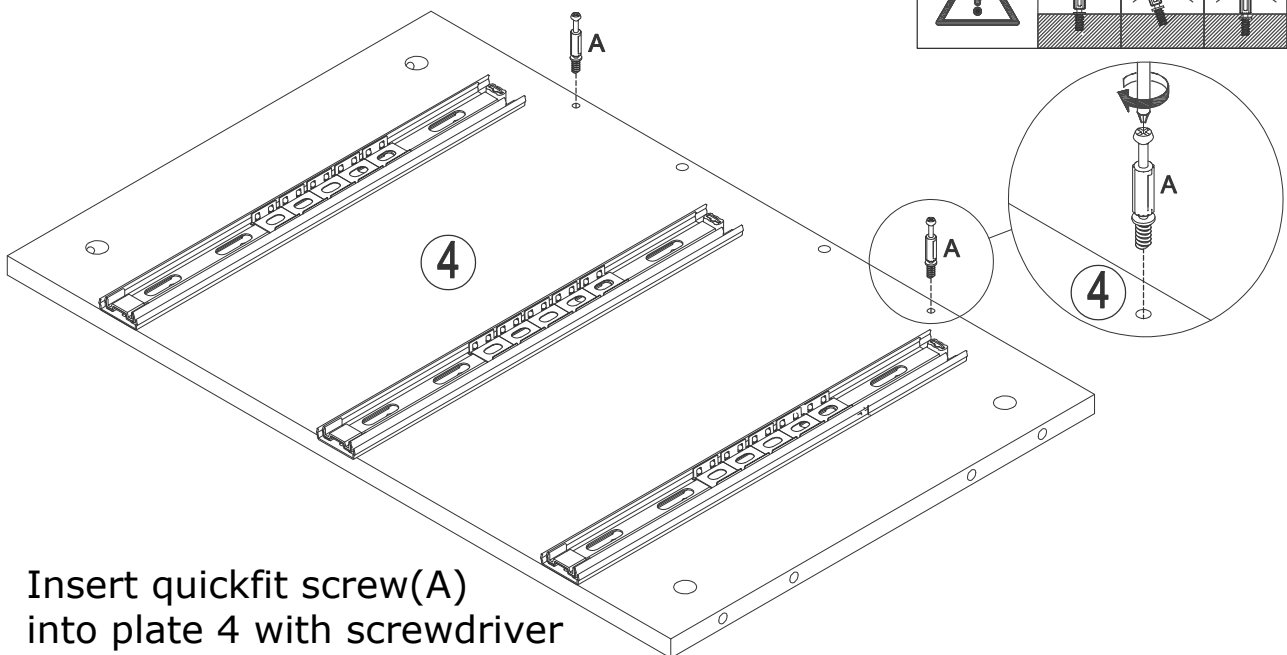
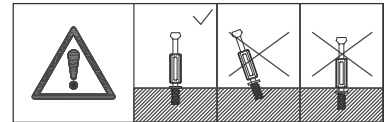
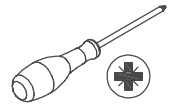

M5x45MM



Insert quickfit screw(A) into plate 4 with screwdriver as shown.

9

B x 4

Ø15x10MM

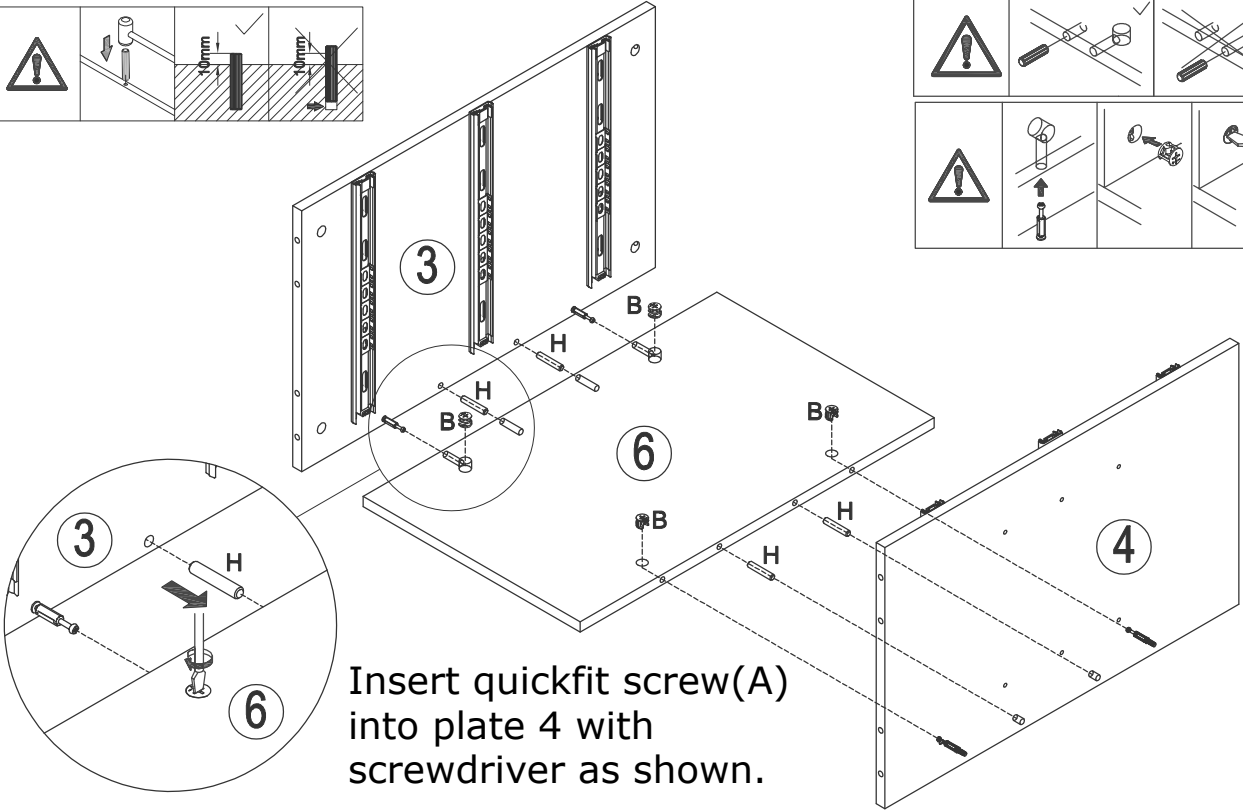
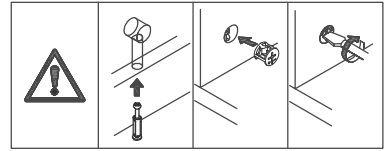
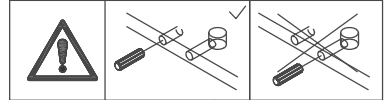
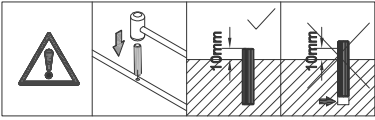
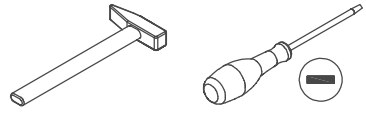
H x 4

Ø8x40MM

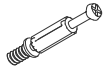

Insert quickfit screw(A)
into plate 4 with
screwdriver as shown.

10

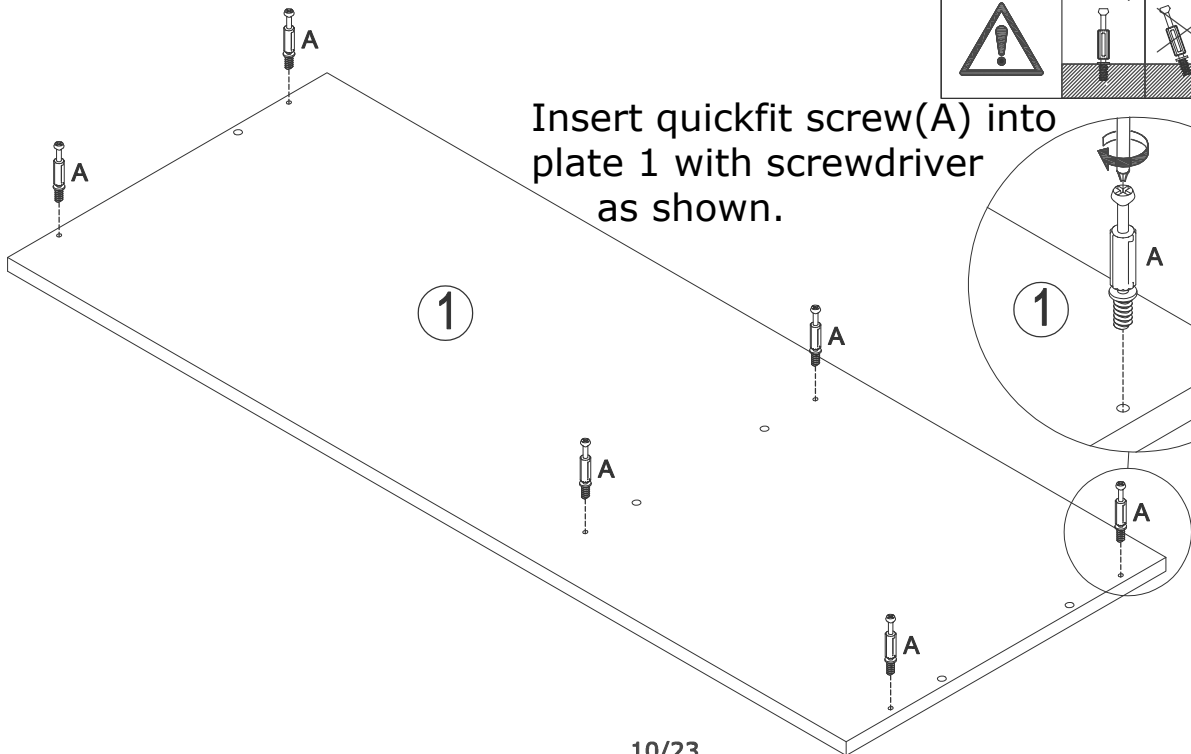
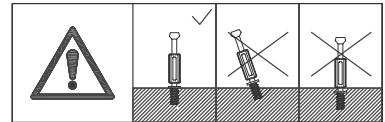
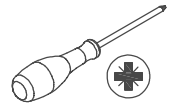
A x 6

M5x45MM



Insert quickfit screw(A)
into plate 1 with screwdriver
as shown.

11

B x 6



Ø15x10MM

H x 5



Ø8x40MM

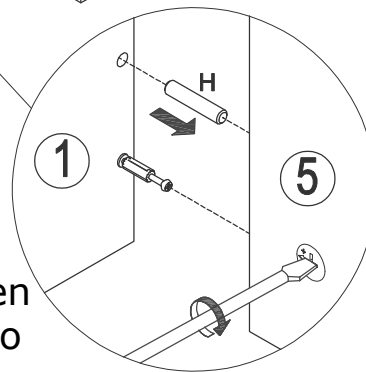
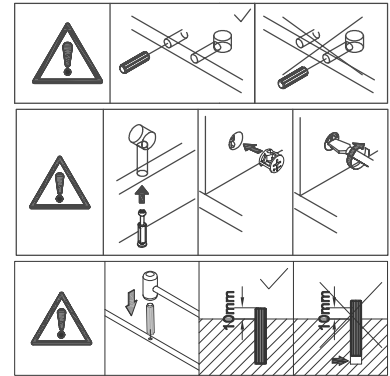
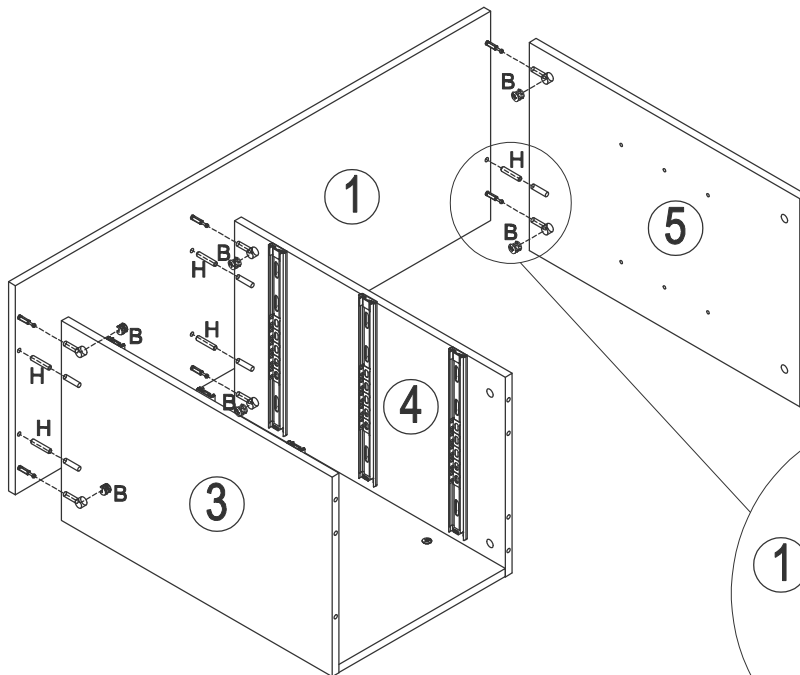
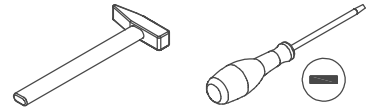

Cover plate 1 to plate 3,4,5 with wooden dowel(H),turn cam locks(B) clockwise to tighten as shown.

12

A x 6

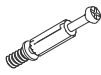

M5x45MM

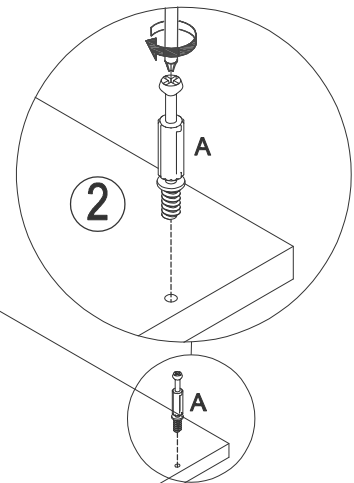
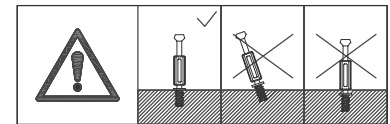
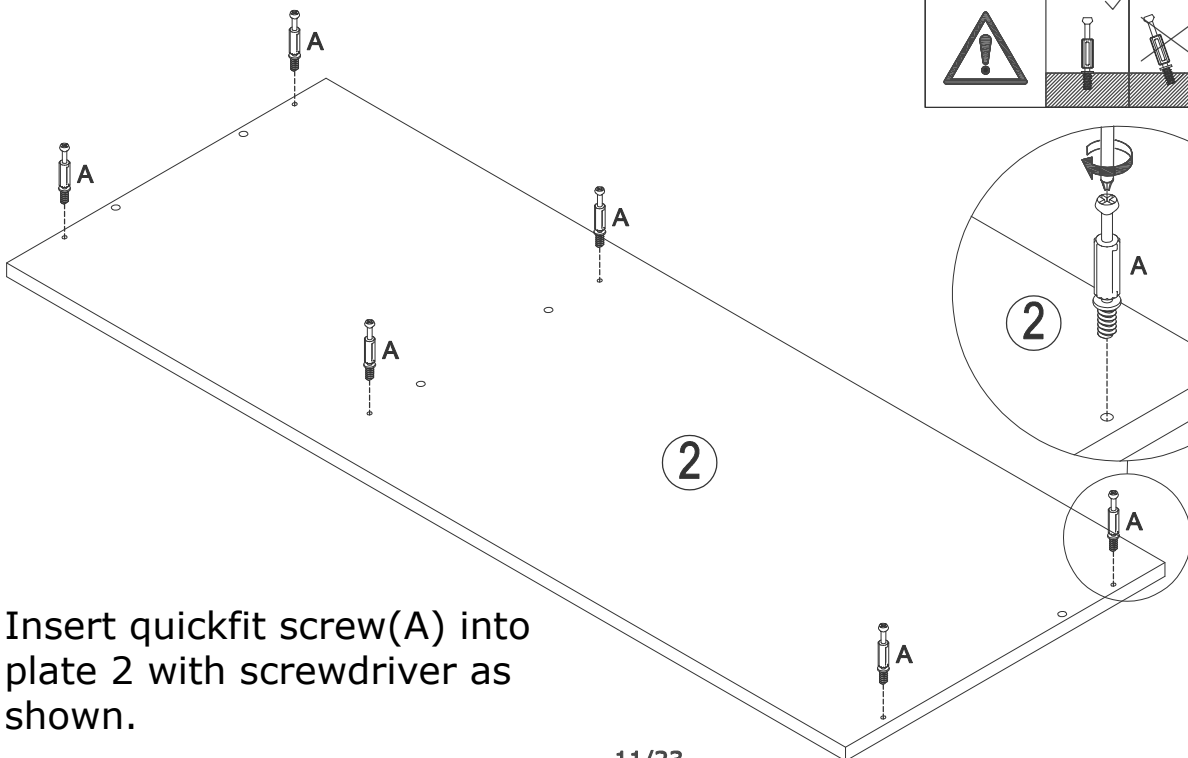
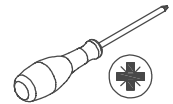

Insert quickfit screw(A) into plate 2 with screwdriver as shown.

13

B x 6



Ø15x10MM

H x 5



Ø8x40MM

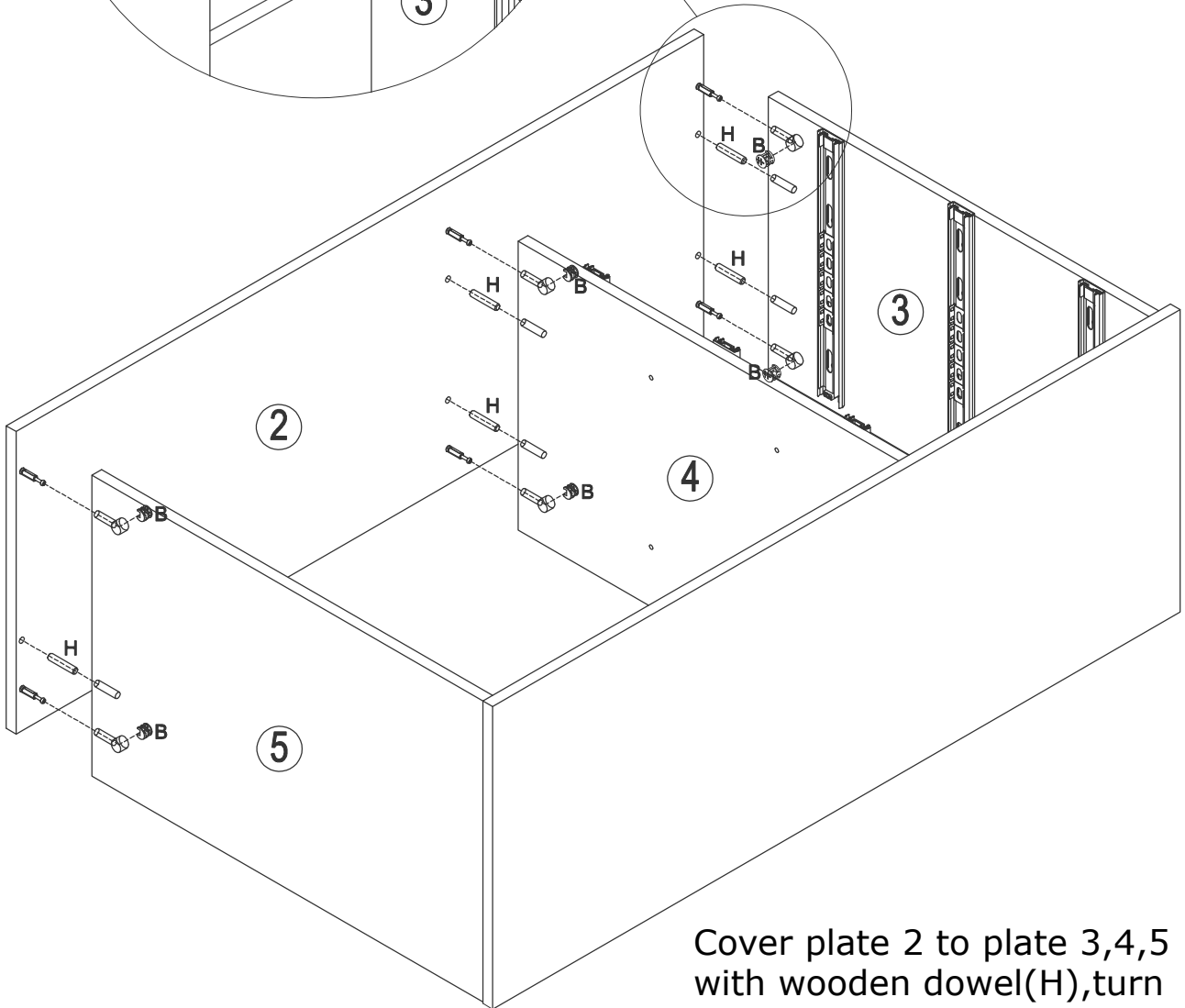
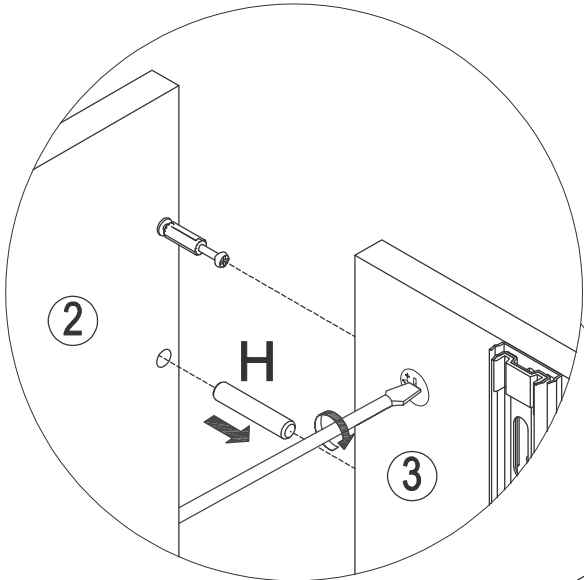
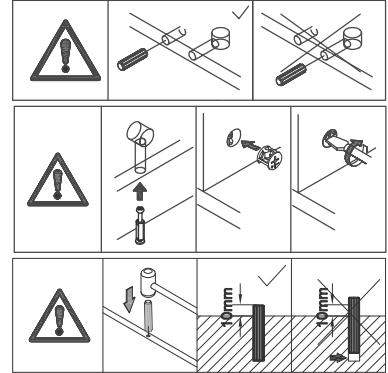
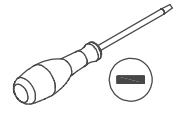
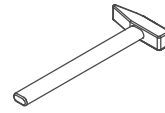

Cover plate 2 to plate 3,4,5 with wooden dowel(H), turn cam locks(B) clockwise to tighten as shown.

14

M x 6
Ø30x3MM

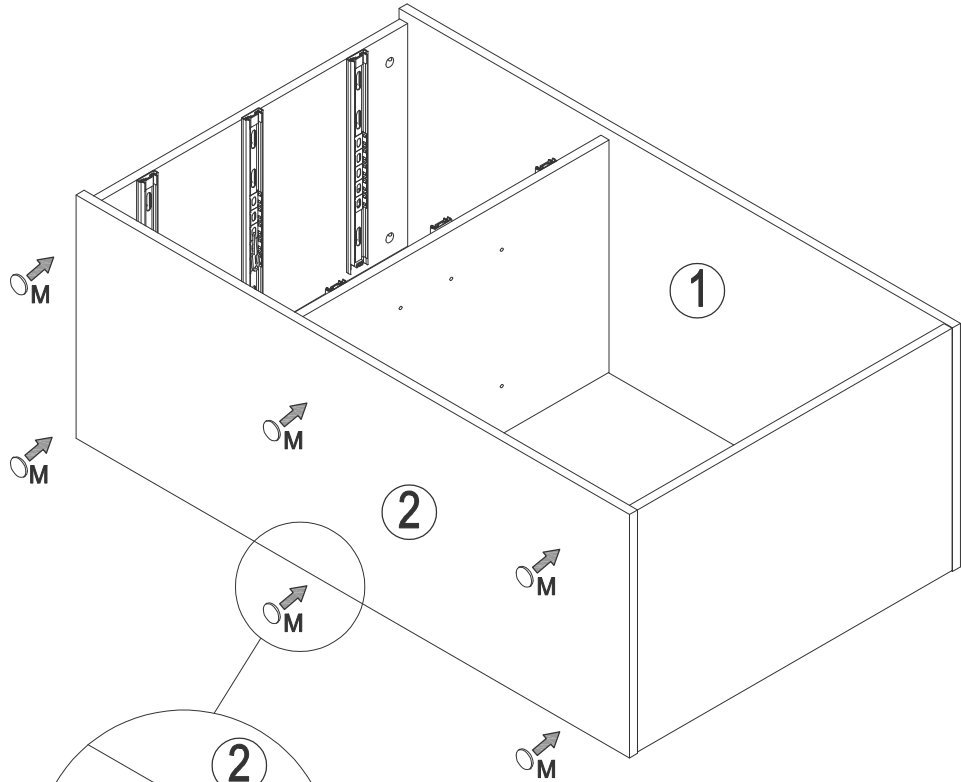

OR

Stick non-slip mat(M) to bottom plate 2 or plate 1 as you like.

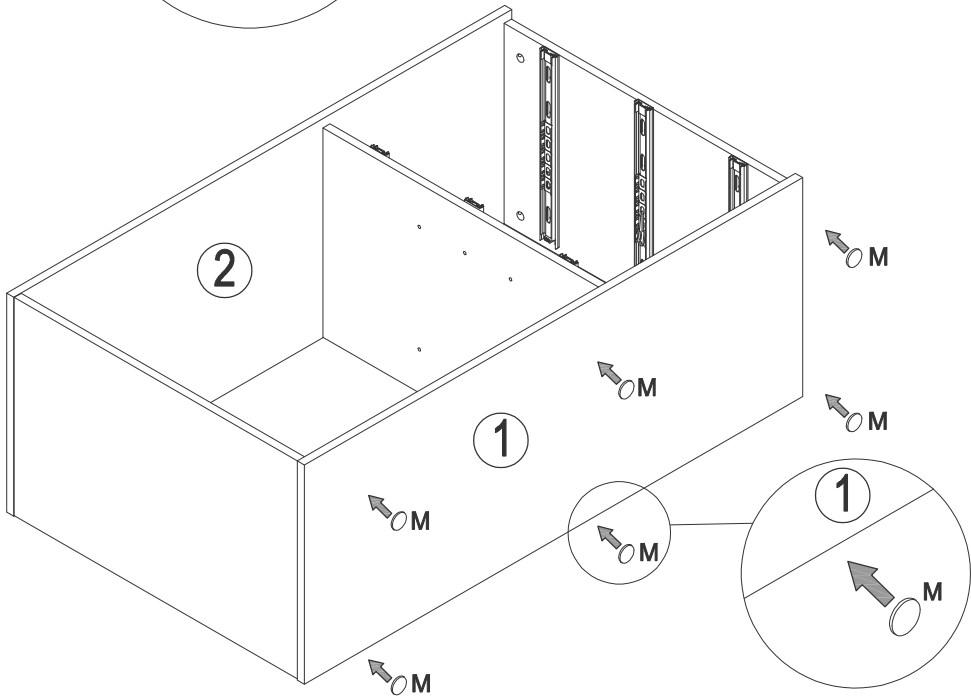

15

I x 4



Ø6

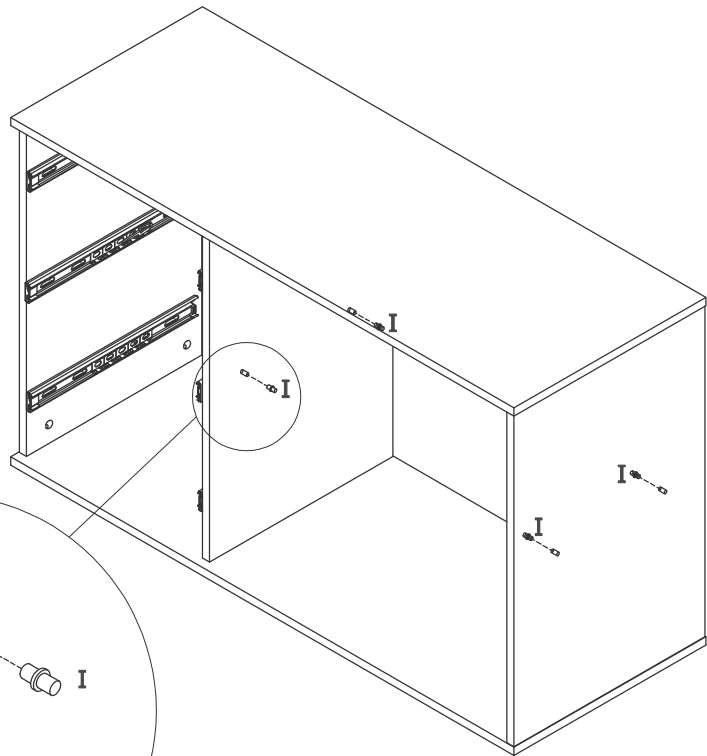

OR

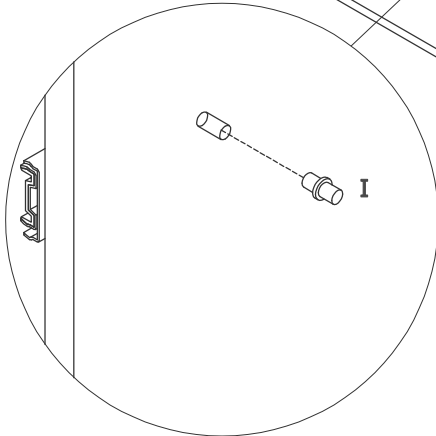

Insert part(I) into a proper position of side plate 4 and 5 as shown.

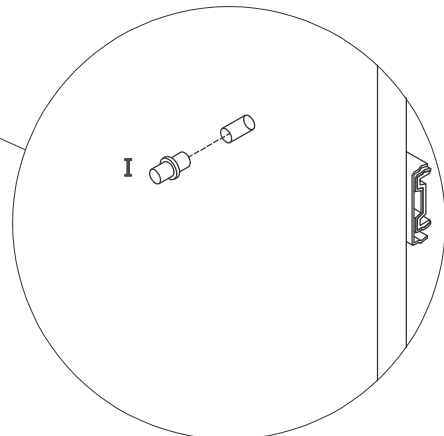
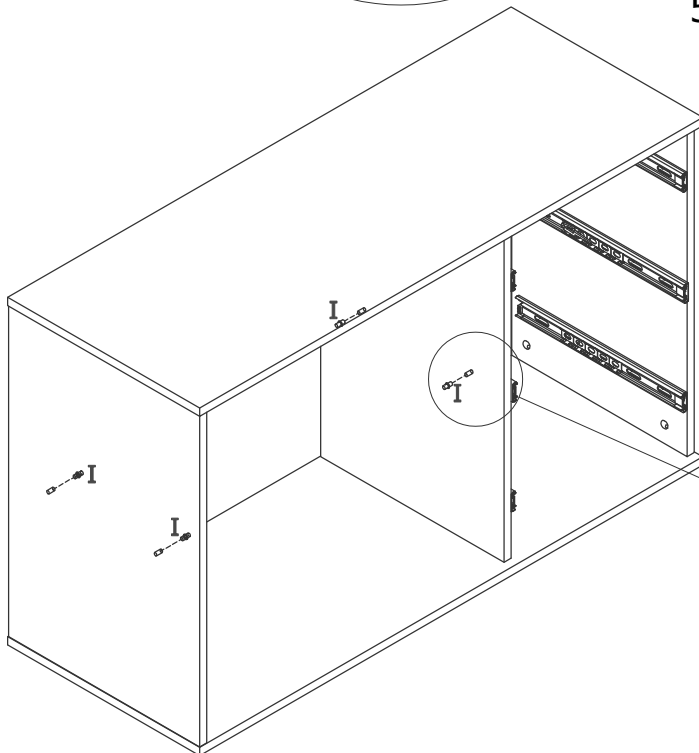

16

Put shelf plate 7 as shown.

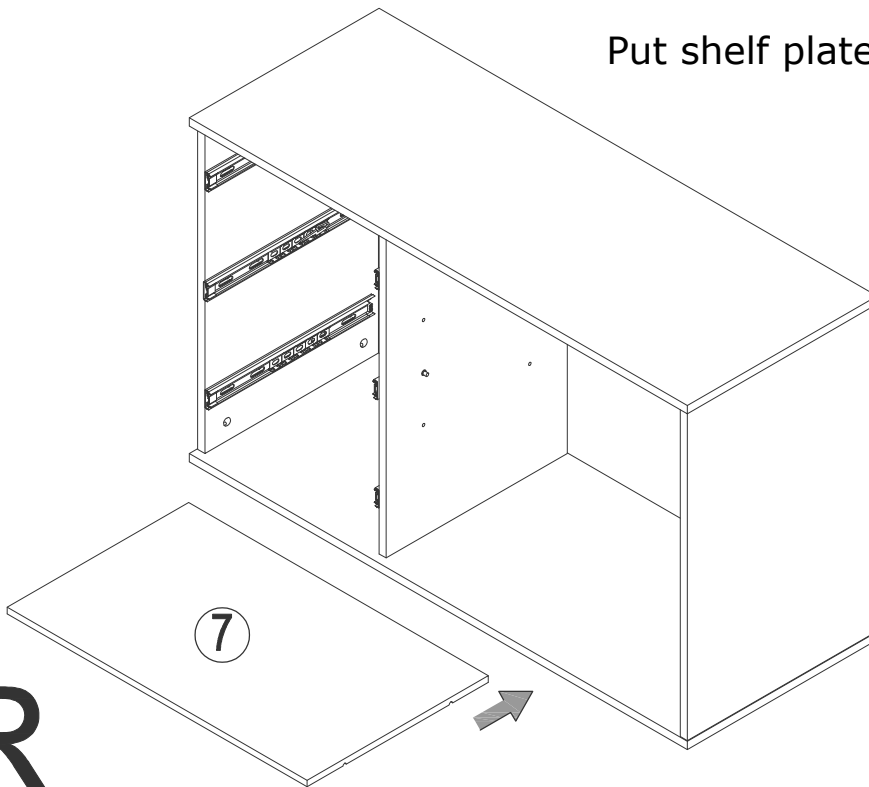

OR

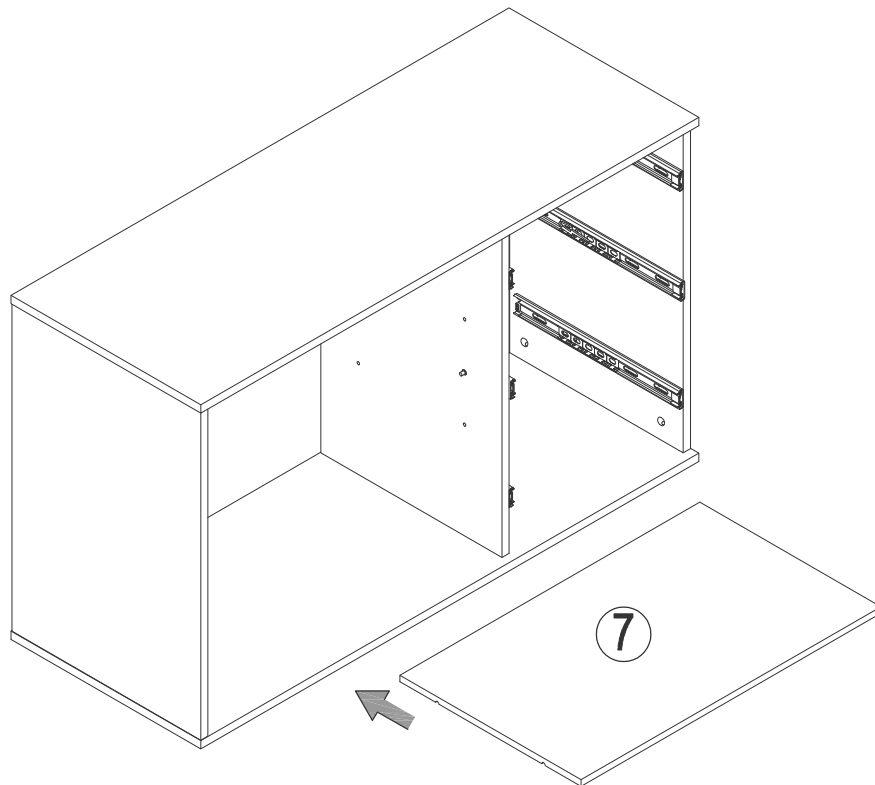

17

A x 12

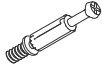

M5x45MM

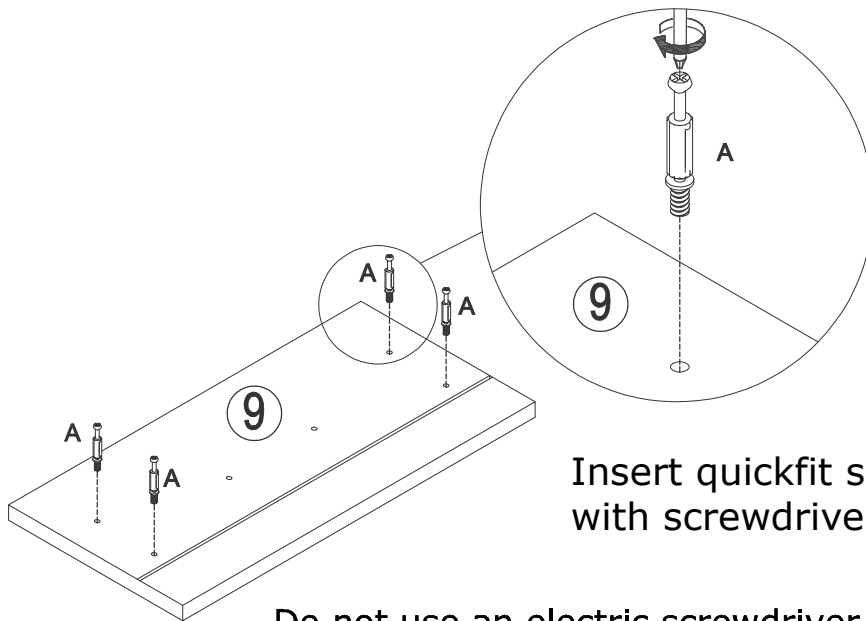
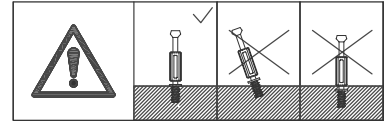
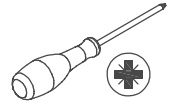

Insert quickfit screw(A) into plate 9 with screwdriver as shown.

Do not use an electric screwdriver, do not use force during the rotation of the accessories, otherwise it may cause the board to crack

X3

18

B x 12



Ø15x10MM

J x 6



M4x18MM

L x 3

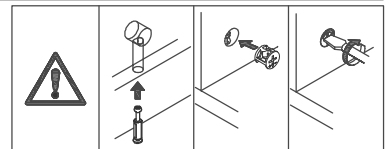
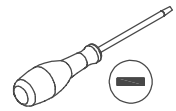
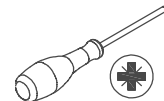

Attach plate 9 to plate 11 and 12, turn cam locks(B) clockwise to tighten as shown. Fix handle(L) to plate 9 with screw(J) as shown.

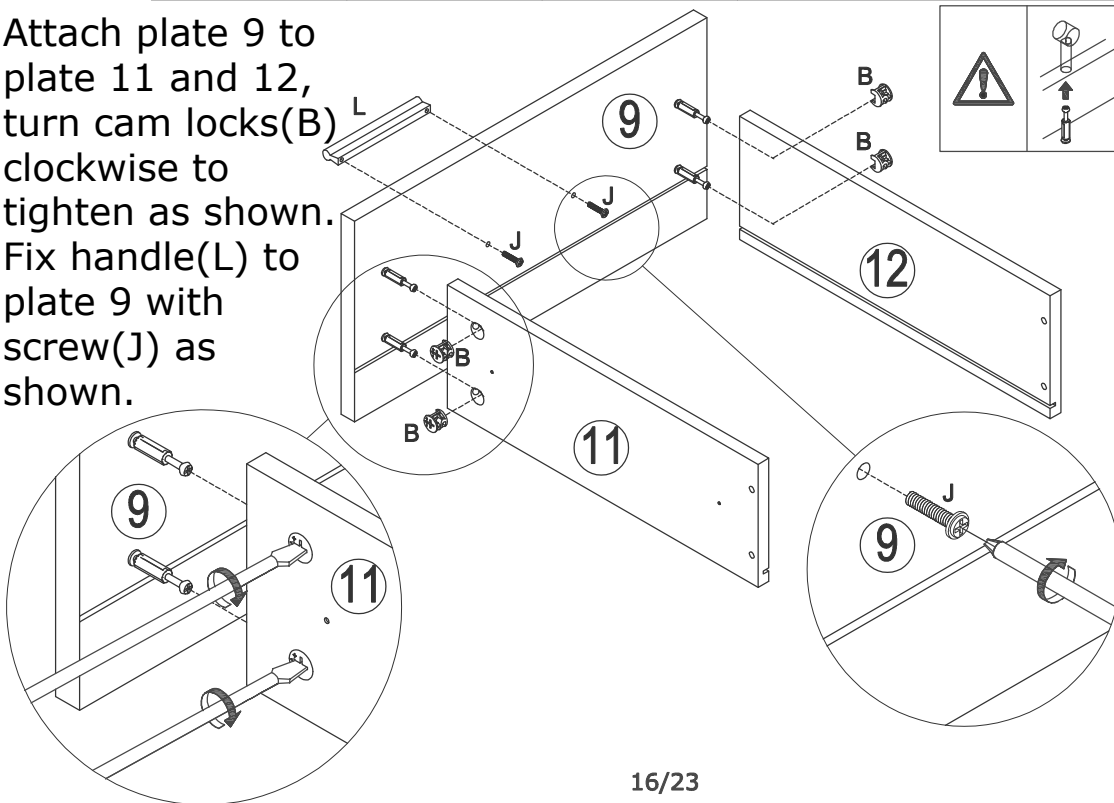

X3

19

Insert plate 13 into available slots as shown.

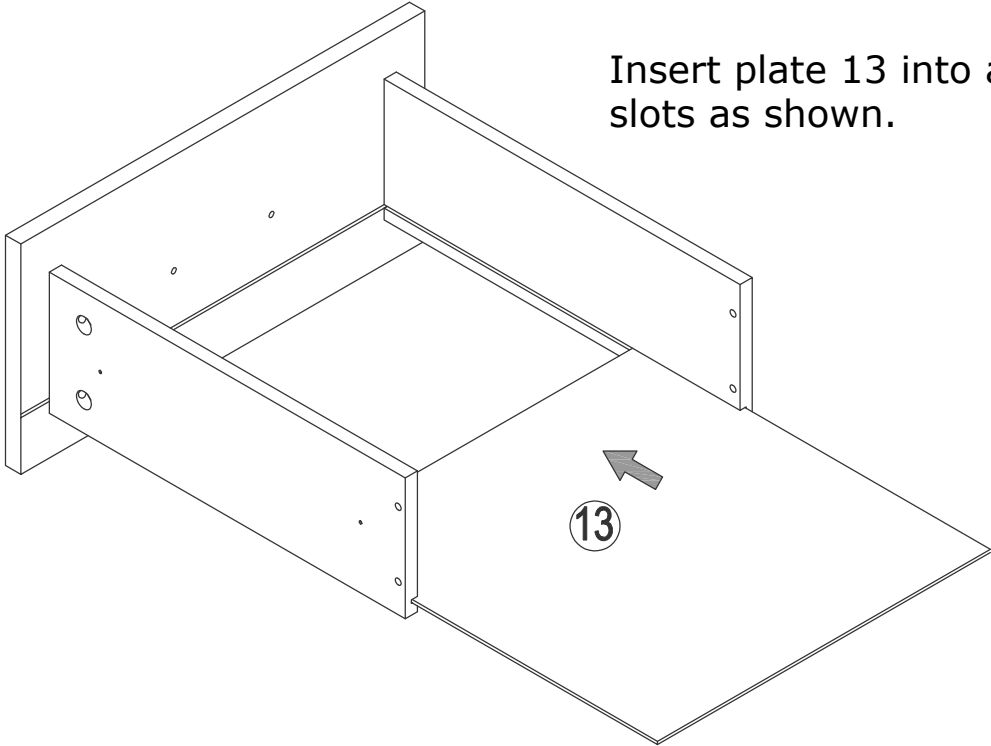

X3

20



Attach plate 10 to the drawer with screw(D) as shown.

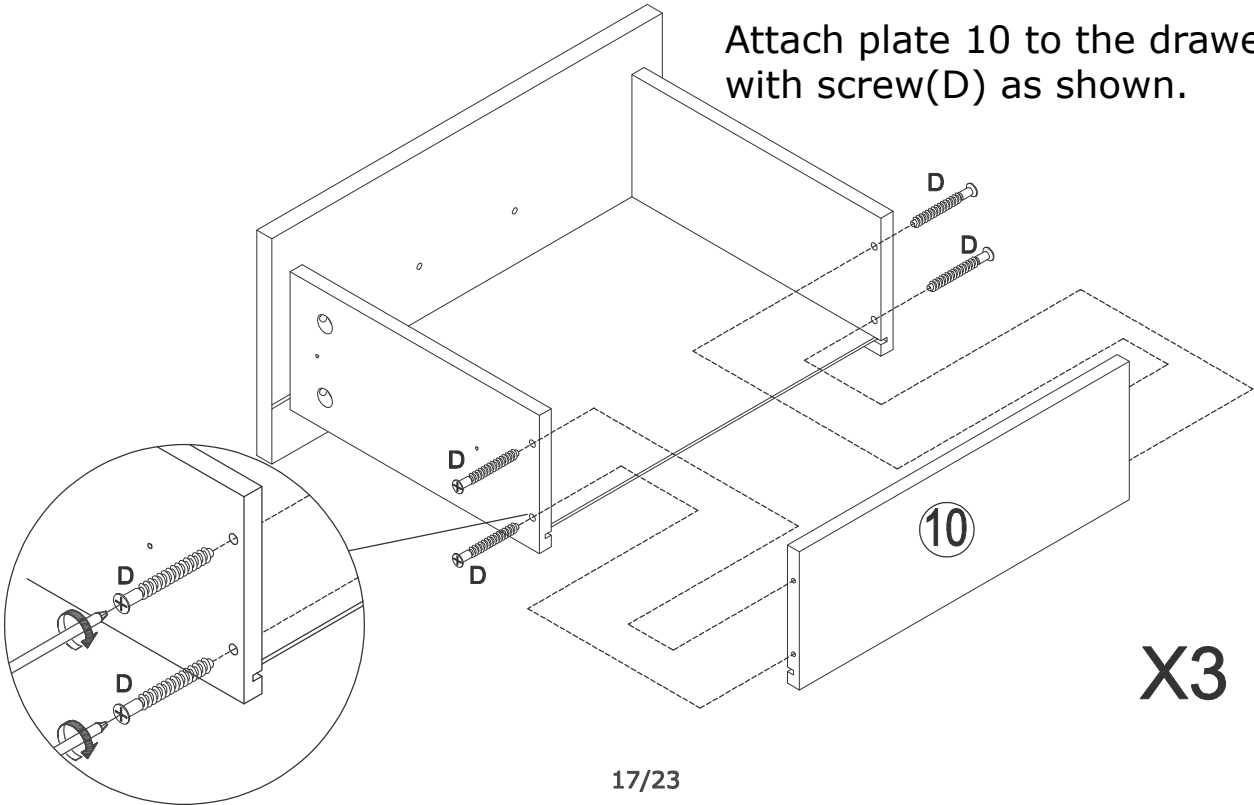

X3

21

C x 12



M3.5x12MM

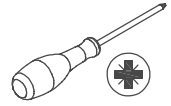

Fix runner 17 to plate 11 and 12 with screw(C) as shown.
Please pay attention to the holes where the accessories are inserted.

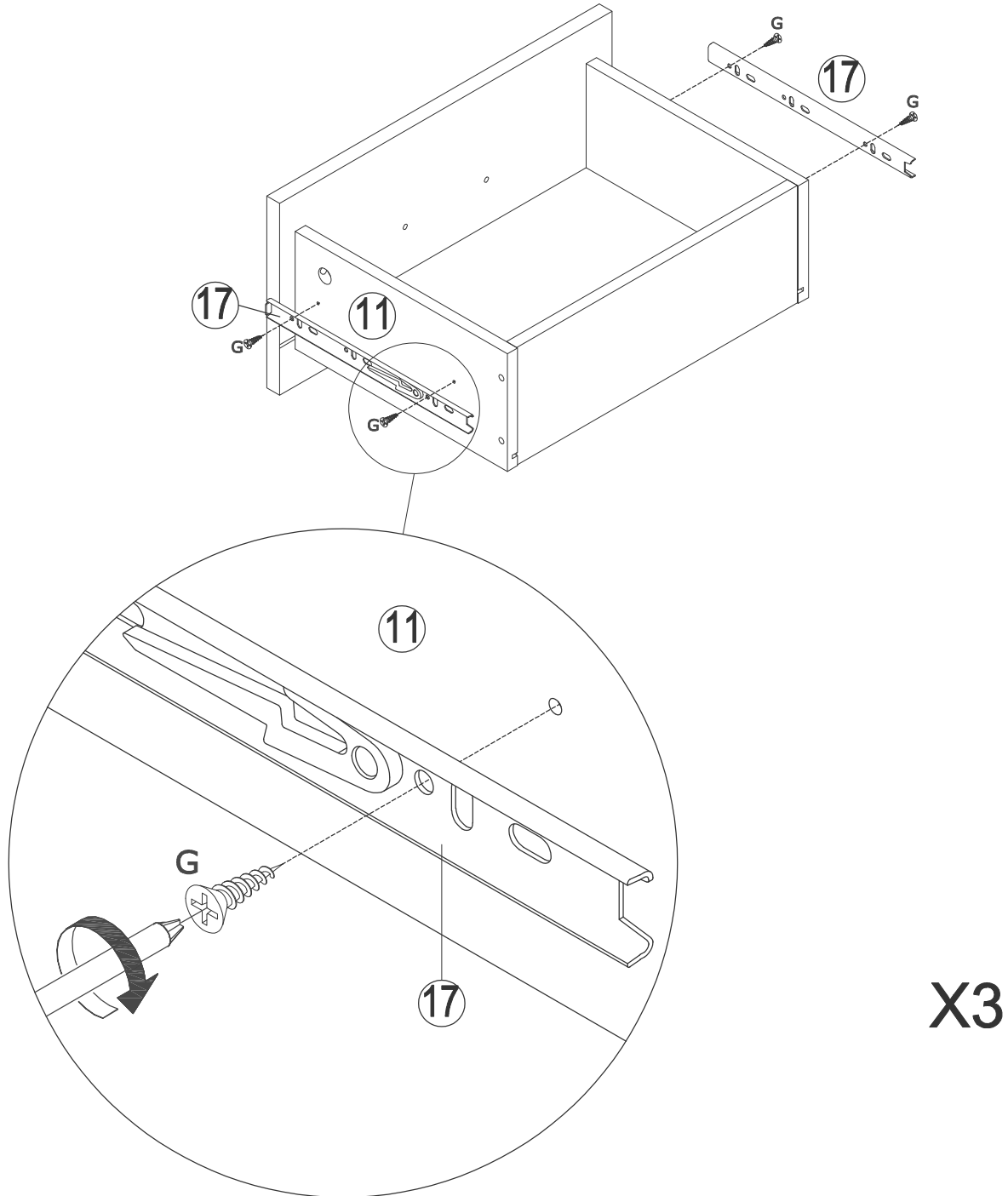

22

Align rails, put all drawers.

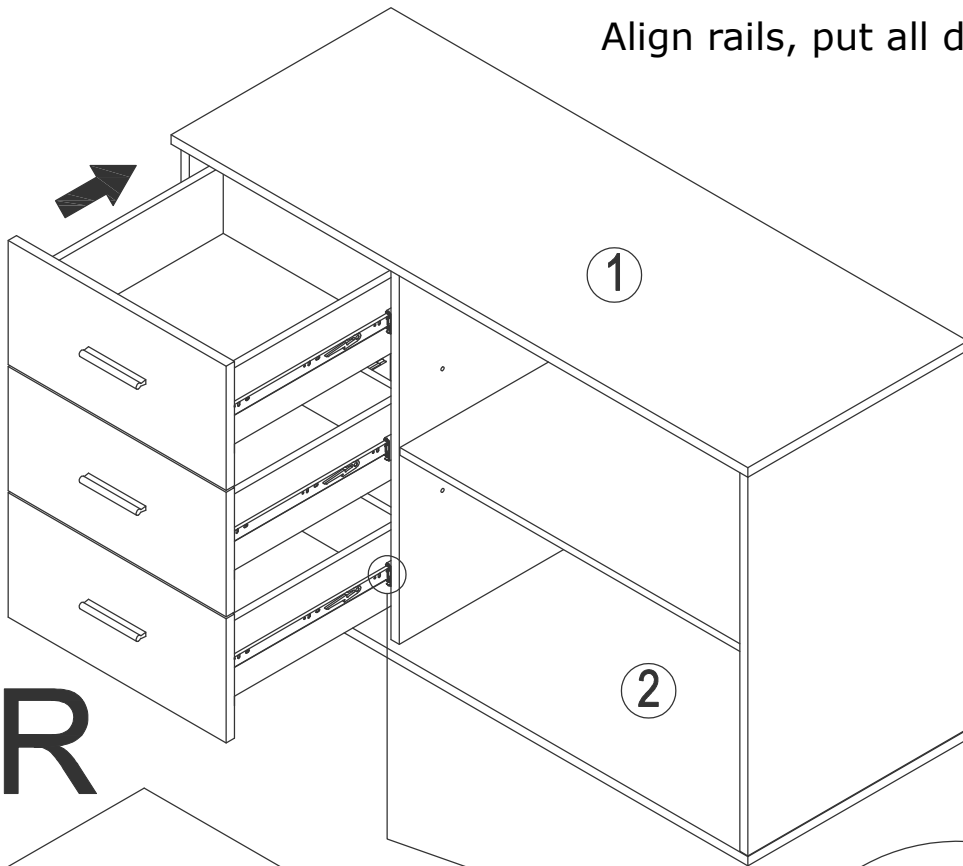

OR

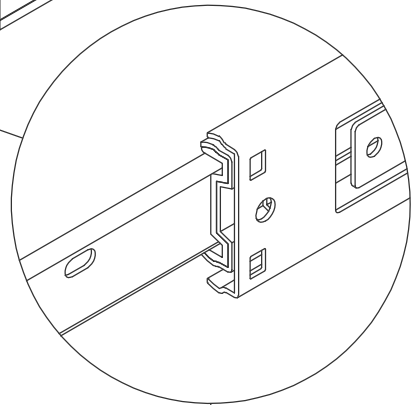
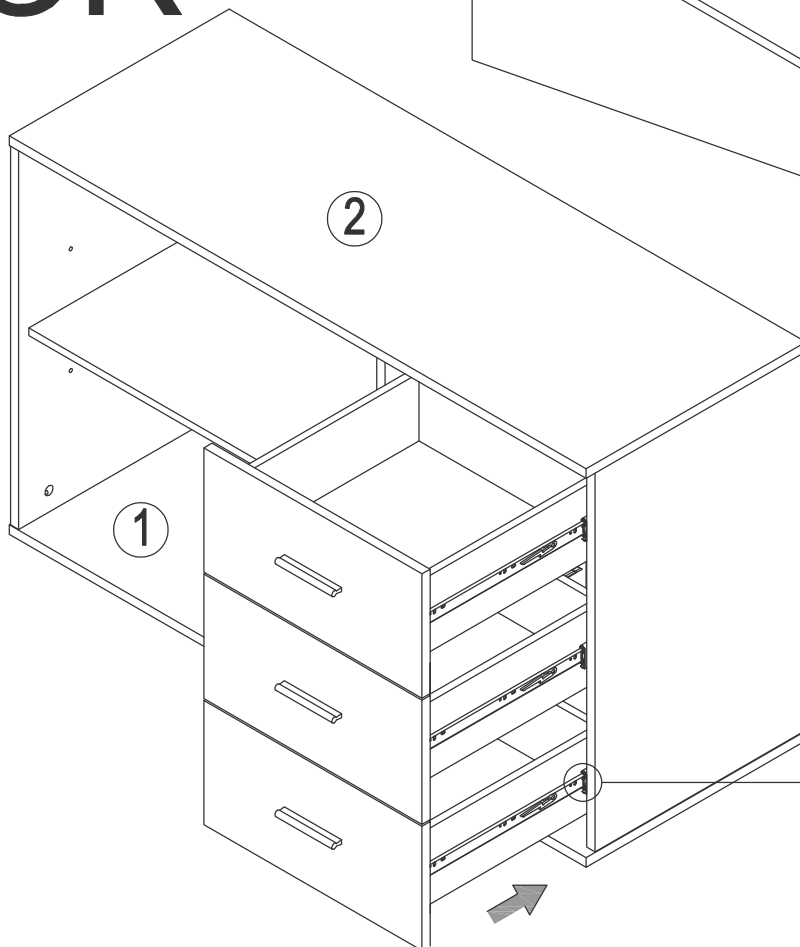

23

Put the table top as shown.

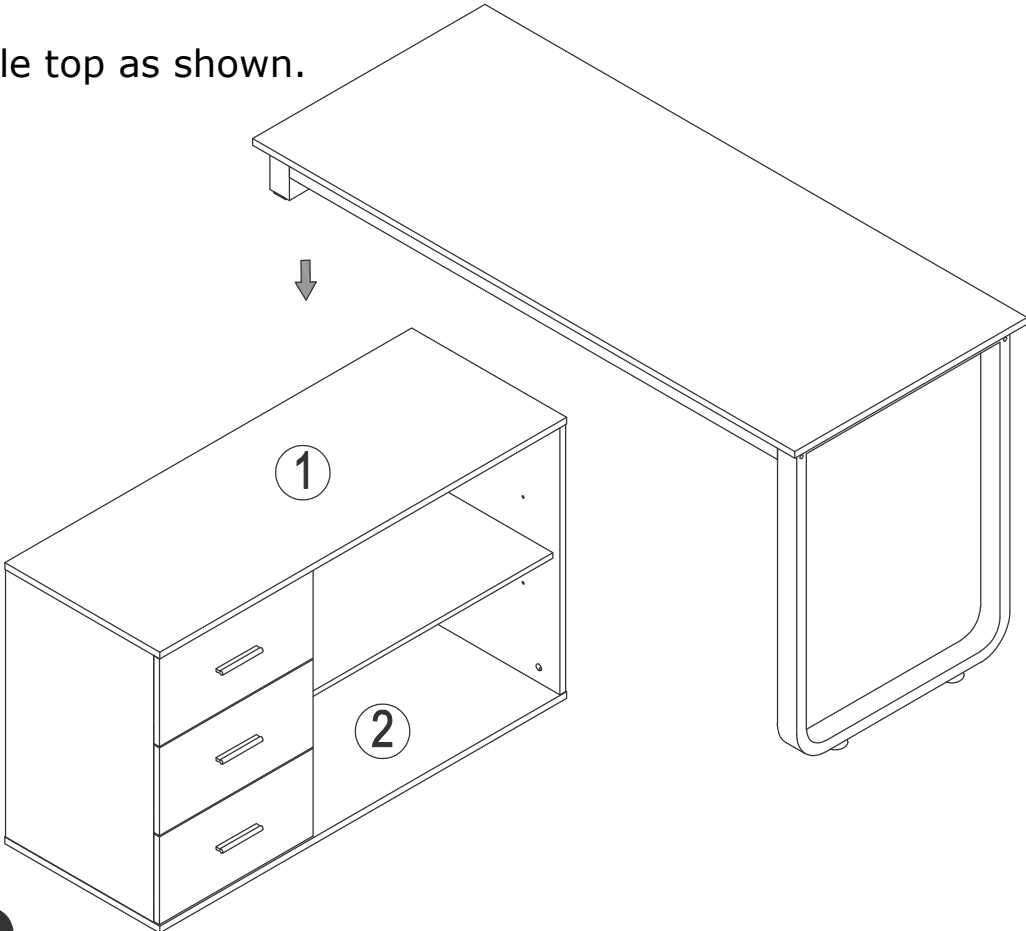

OR

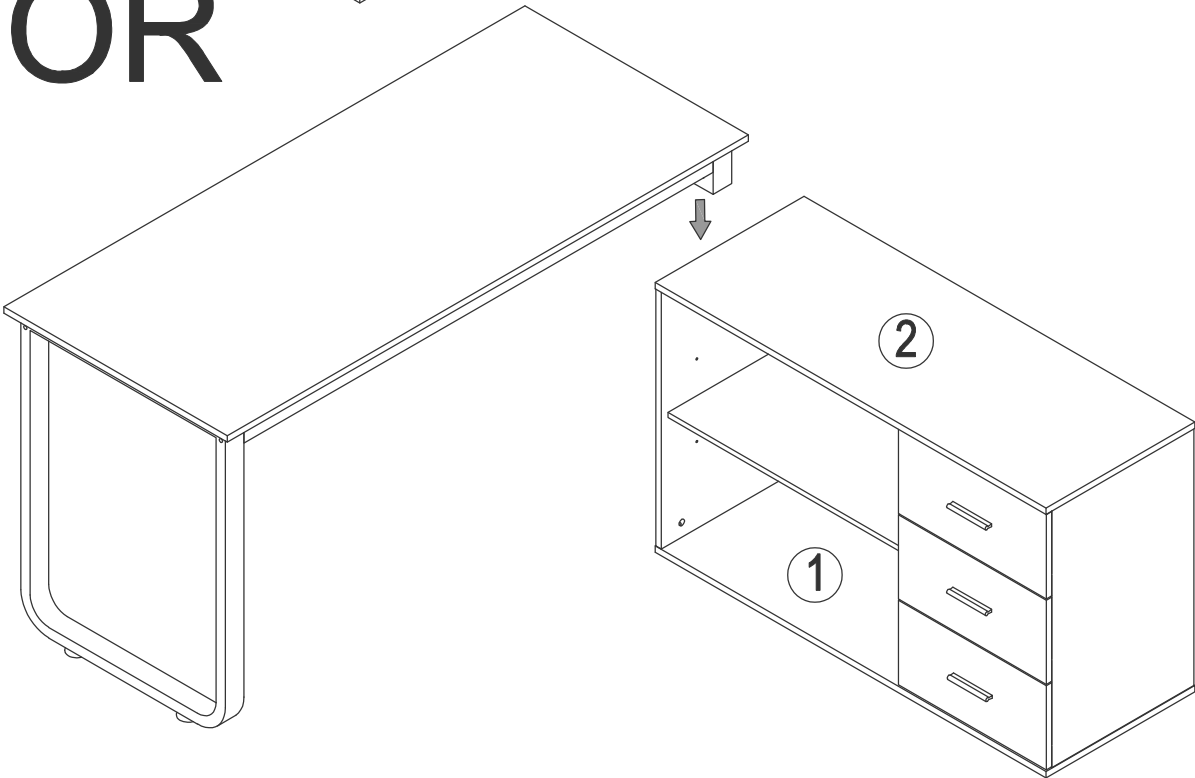

24

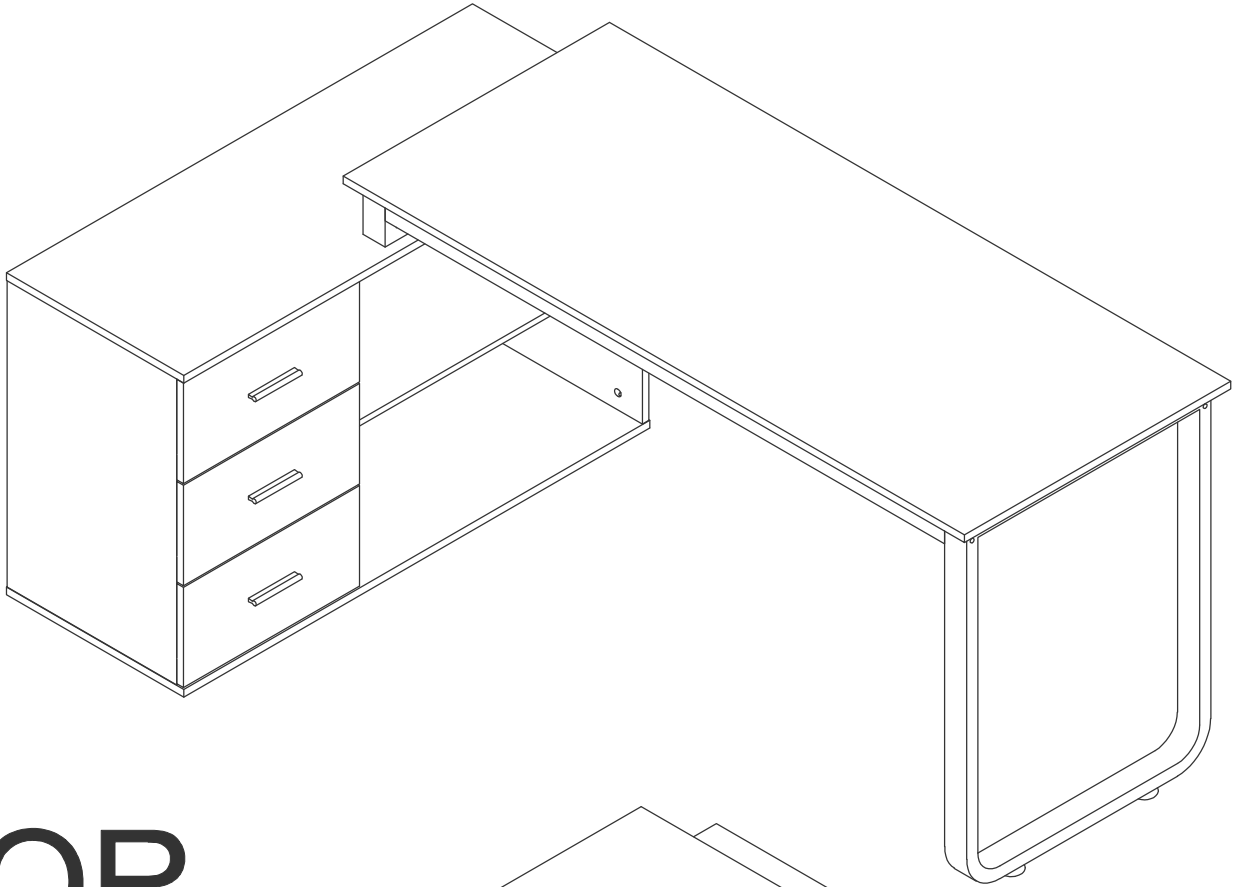

OR

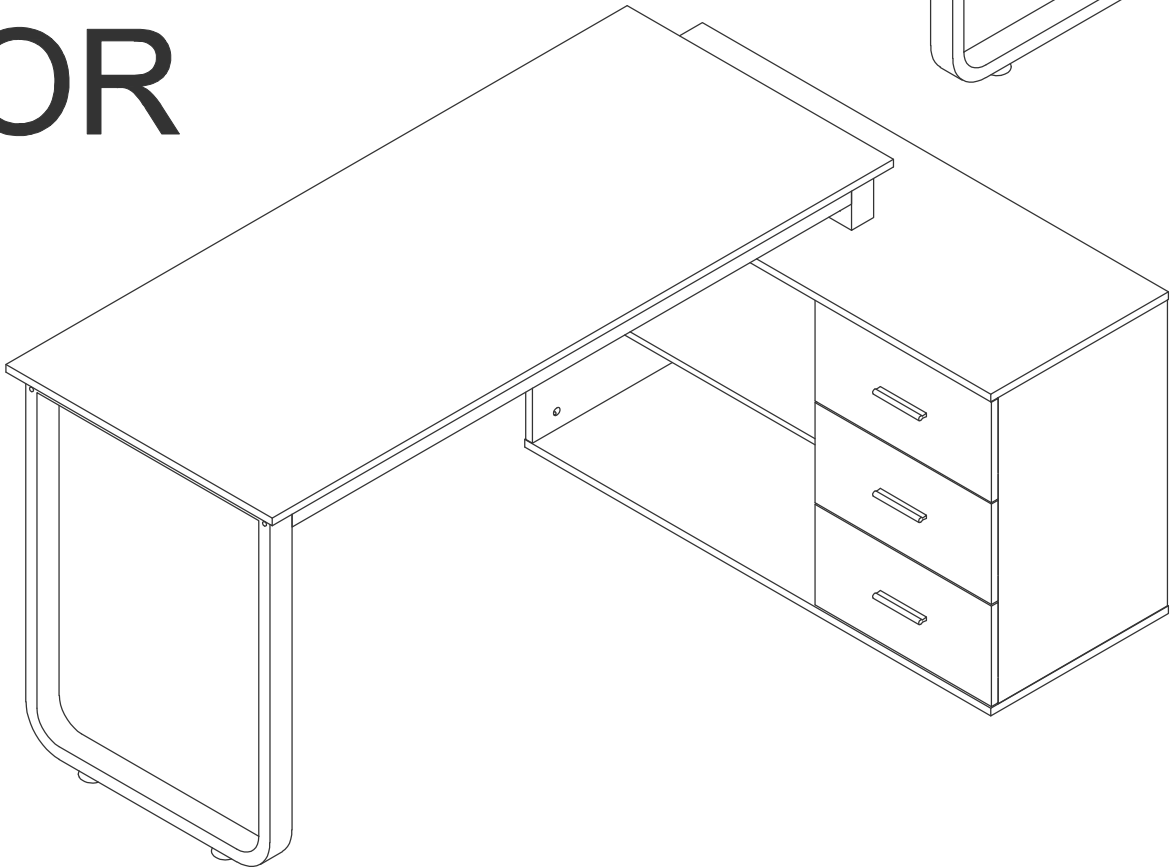

WARRANTY

WARRANTY CLAIMS

- There is a 30-day warranty for broken furniture or any other problems that do not work properly. The warranty will start from the date of purchase which must be verified by proof of purchase.
- Before making a claim, we may be able to answer your query, simply call us. Please leave your purchase order number, along with some details of the problem, if you want a replacement part. We will arrange within 48 hours. If there is out of stock, we will reply with a shipping date.
- The product must be used in accordance with the instructions provided. For health reasons.
- For other reasons, if the furniture needs to be returned, it must be cleaned and dried and operated within 30 days of receipt.

Type of Warranty Claim

- Failure to follow the furniture instructions will invalidate the warranty. Attention please.
- Does not include damage during installation, but includes damage during transportation.

Scope of responsibility

- Shall not bear any responsibility for misuse or user damage and / or loss of parts during the installation of furniture.
- After using, the damage and scratches of the furniture are not covered by the warranty.

The Warranty Relates to All Bought in The Us and Covers The Following Areas

- Sheet parts: 1 month from the date of purchase.
- Electrical parts: 1 month from the date of purchase.

RETURNS

CHANGED YOUR MIND AND NEED TO RETURN YOU ITEM?

PLEASE FOLLOW THE BELOW INSTRUCTIONS:

- If you have purchased and have simply changed your mind, follow the retailer's instructions for returns.

DEFECTIVE ITEMS

- If your item is defective in any way, i.e. it doesn't work but you can't identify why, in the first instance, please call us.

DAMAGED ITEMS

- If you receive an order with obvious shipping damage from the retailer, then we suggest the delivery is refused. If the delivery has been accepted and then shipping damage is found, please follow the specific instructions advised by the retailer.
In all circumstances please save all packaging material and paperwork for the order. Please be aware that if you dispose of packaging material or attempt to return the merchandise without contacting the fulfiller, you jeopardise your chances of making a claim, and you may not receive a credit for the return.