

NOTE:

This brochure contains IMPORTANT safety info. Please read and keep for future reference.

MAINTAINANCE AND WARNING

- 1.Keep furniture away from heat sources.
- 2.Do not clean furniture with harsh cleaner or polishes.Do not use detergents,solvents,abrasives,spray packs or leather cleaner. Use non-color mild soa with warm water to clean spills(Mix 1:10 soap to water).
- 3.Do not place furniture under direct sunlight,material will possibly fade over time.
- 4.Do not use on site dry cleaning machine.Children should not climb or jump on the furniture.
- 5.Do not write on furniture that is not protectedby a padded barrier.
- 6.Not for commercial use,only for residential use.



Weight Limitation
40 LBS

EXPLOSIVE VIEW

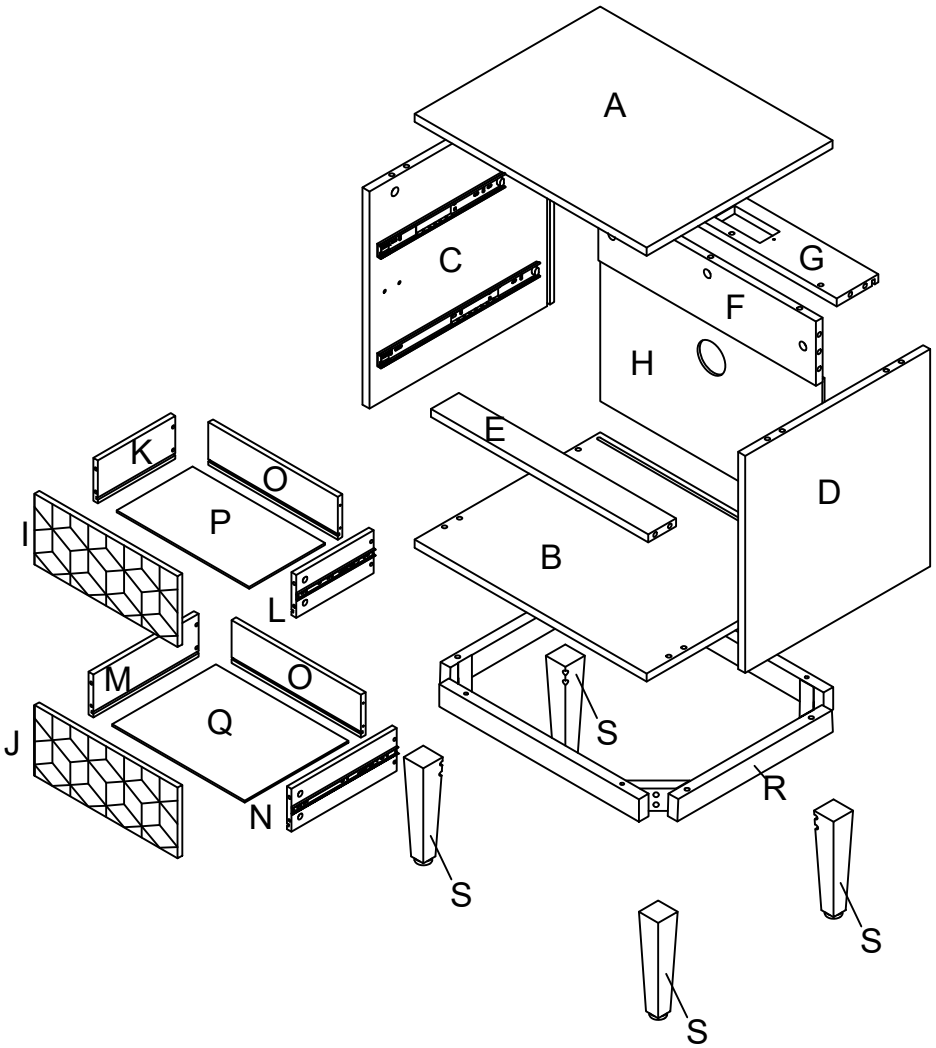



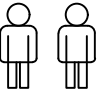



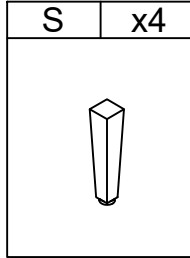
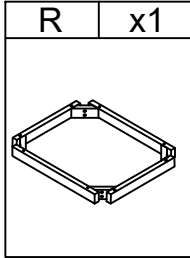
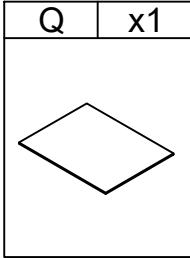
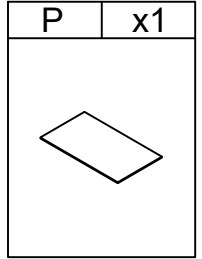
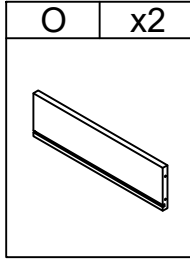
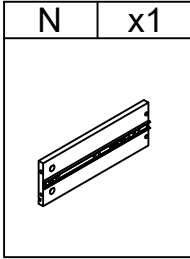
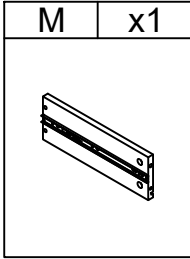
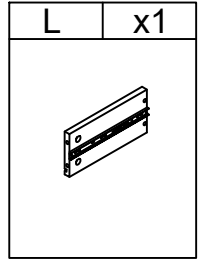
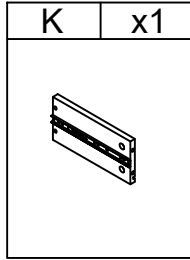
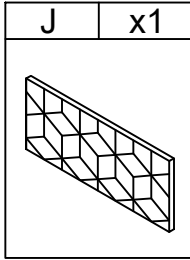
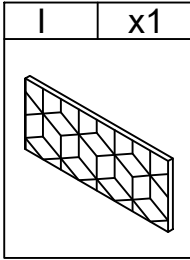
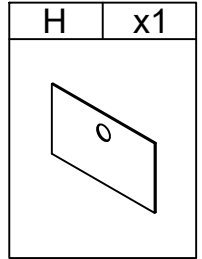
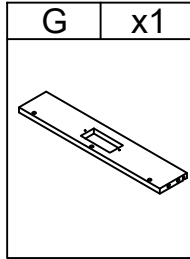
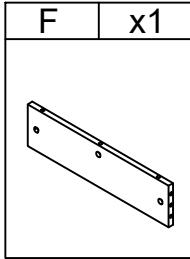
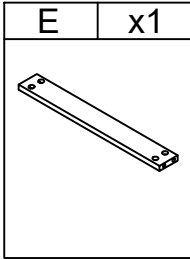
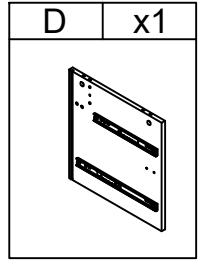
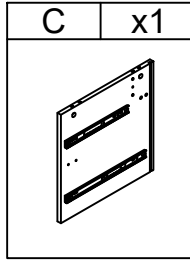
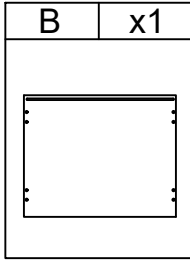
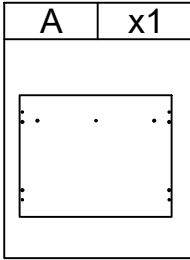



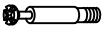



2PERSONEN





PARTS LIST

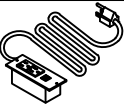





HARDWARE LIST

#1 x21  M6*35mm	#2 x21  Ø15mm*11mm	#3 x4  M7*50mm	#4 x16  Ø8*30mm	#5 x12  M3.5*14mm	#6 x4 
#7 x13  M4*35mm	#8 x1 	#9 x2  Ø8*30mm	#10 x2 	#11 x16  M6*50mm	#12 x21  Ø20
#13 x2 	#14 x1 	#15 x1 			

TOOL LIST

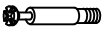
#16 x1 	#17 x1  M4
---	---

HARDWARE SPARE LIST

#1 x2  M6*35mm	#3 x1  M7*50mm	#5 x1  M3.5*14mm	#7 x1  M4*35mm	#11 x1  M6*50mm
---	---	---	---	--

ASSEMBLY INSTRUCTIONS

STEP-1

Insert bolt #1 into the corresponding hole of drawer front(I),tighten bolt #1 with screwdriver #16.

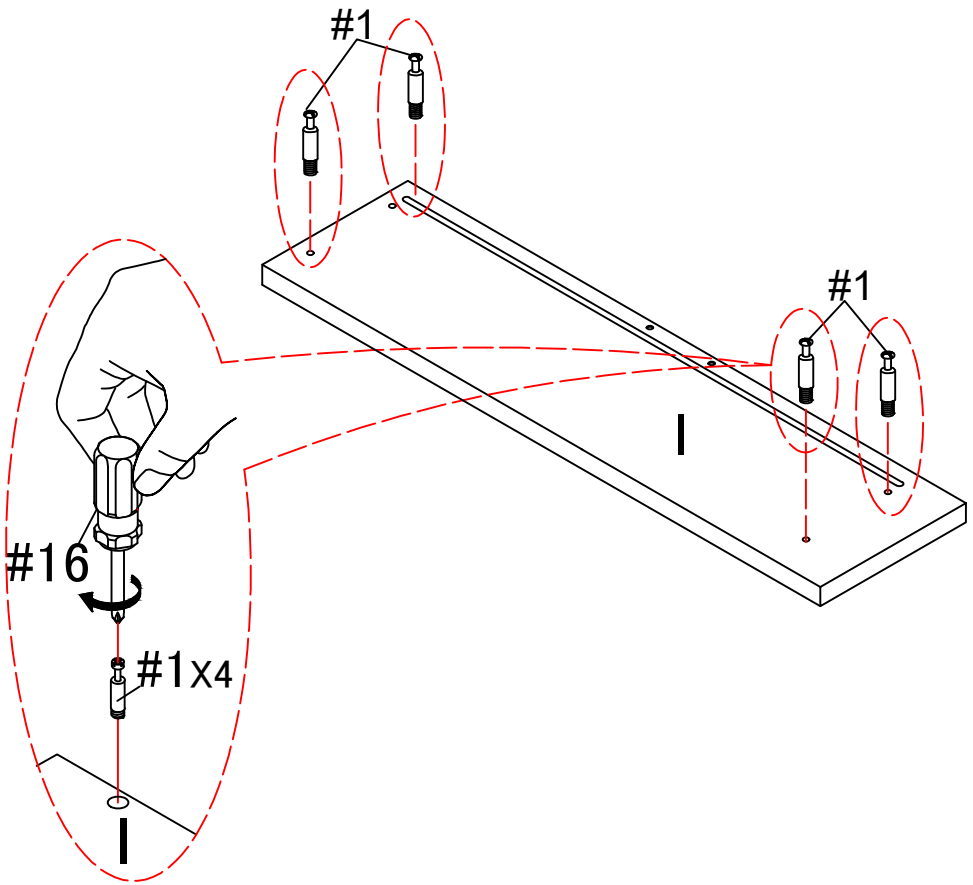

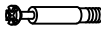

#16	x1	#1	x4
			
M6*35mm			

ASSEMBLY INSTRUCTIONS

STEP-2

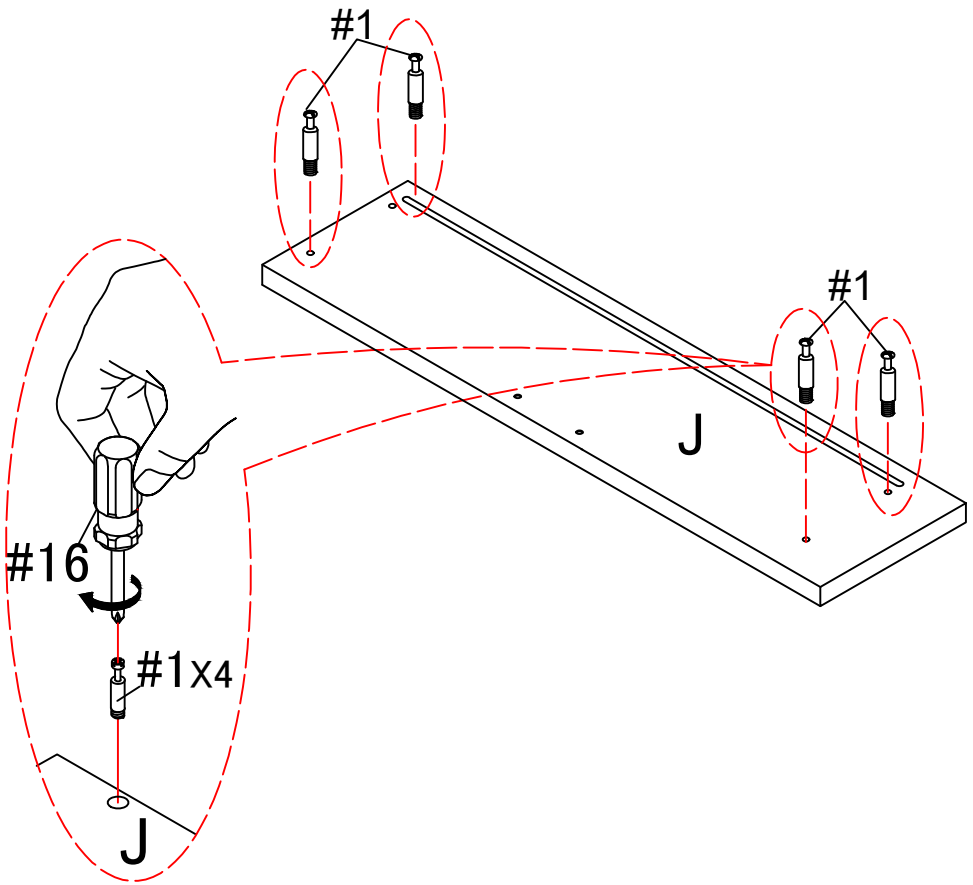
Insert bolt #1 into the corresponding hole of drawer front(J), tighten bolt #1 with screwdriver #16.

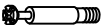

#16	x1	#1	x4
			
M6*35mm			



ASSEMBLY INSTRUCTIONS

STEP-3

Use bolt #7 to attach drawer side(K)&(L)to drawer back (O),tighten bolt #7 with screwdriver#16 , and slide in the part (P) into the groove in part (K)&(L) . make sure they are also in groove in part (O).

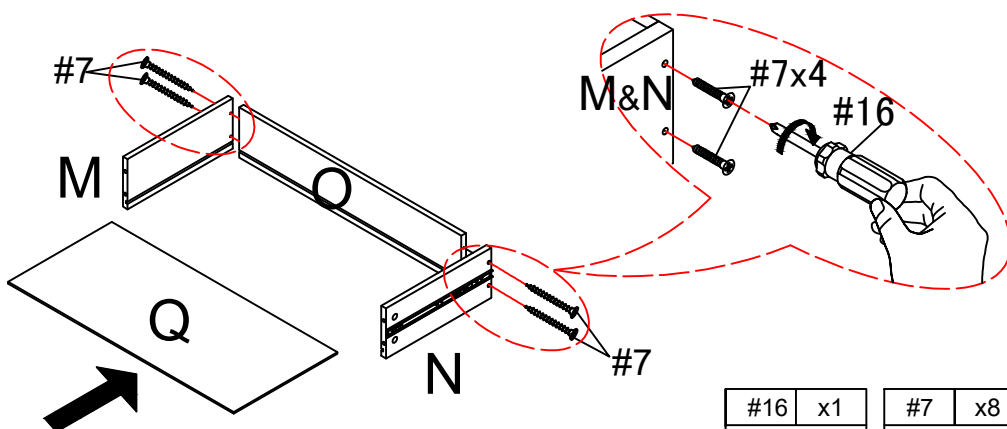
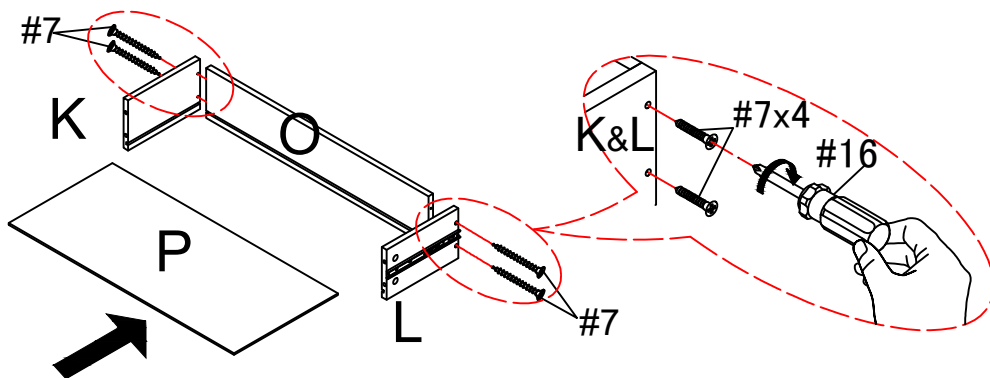
Use bolt #7 to attach drawer side(M)&(N)to drawer back (O),tighten bolt #7 with screwdriver# 16 , and slide in the part (Q) into the groove in part (M)&(N). make sure they are also in groove in part O.



#16	x1	#7	x8
			
ø4*35mm			

ASSEMBLY INSTRUCTIONS

STEP-4

Insert drawer front (I)&(J) into preassemble step 3, make sure all holes aligned and insert cam bolt #2 into the corresponding hole of drawer side panel(K)&(L)&(M)&(N), tighten cam bolt #2 with screwdriver #16. after installation, cover the screw holes with #12.

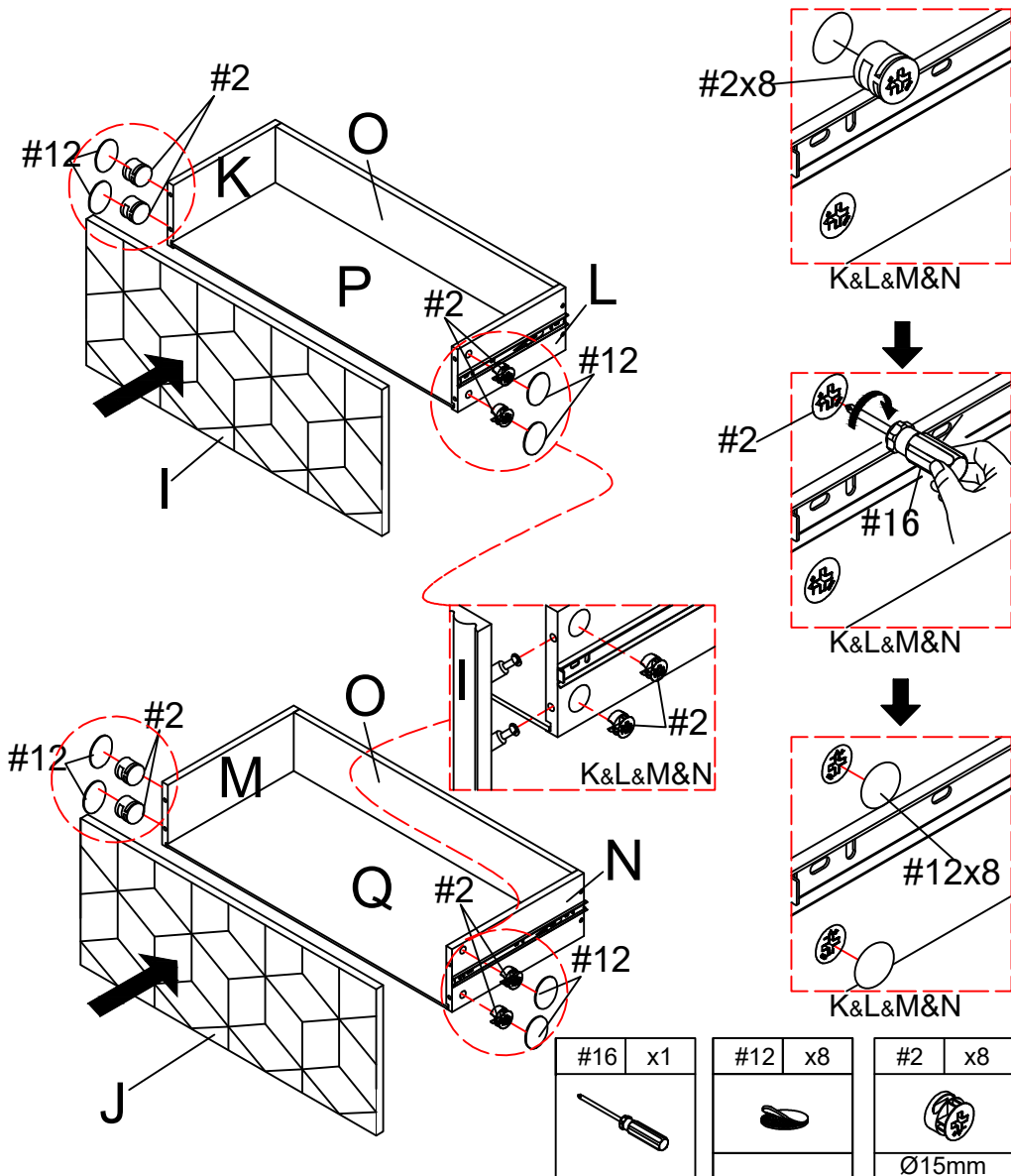



ASSEMBLY INSTRUCTIONS

STEP-5

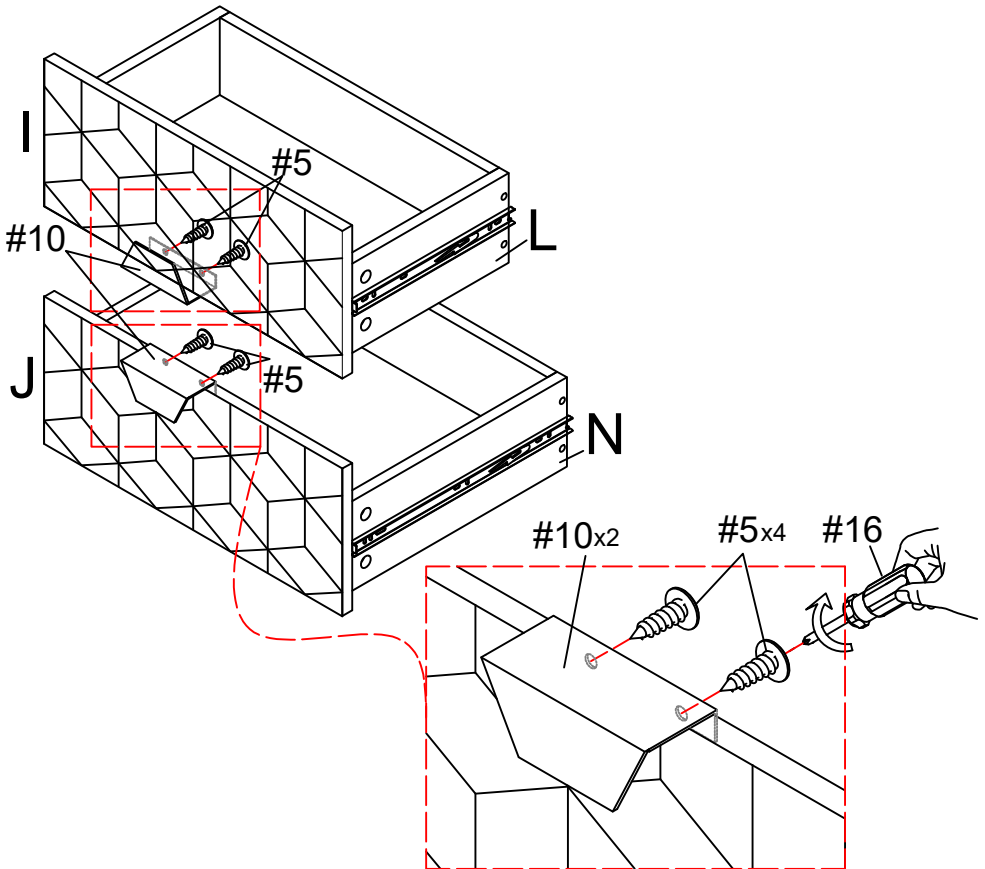
Use bolt #5 to attach handle #10 to drawer front(I)&(J), tighten bolts #15 with screwdriver #16.



#16	x1
	

#5	x4
	
Ø3.5*14mm	

#10	x2
	

ASSEMBLY INSTRUCTIONS

STEP-6

Align the holes of the (G) part with the holes of the (F) part, insert the screw #7, and tighten the screw #7 with the screwdriver #16 and insert wooden dowel #4 by hand.

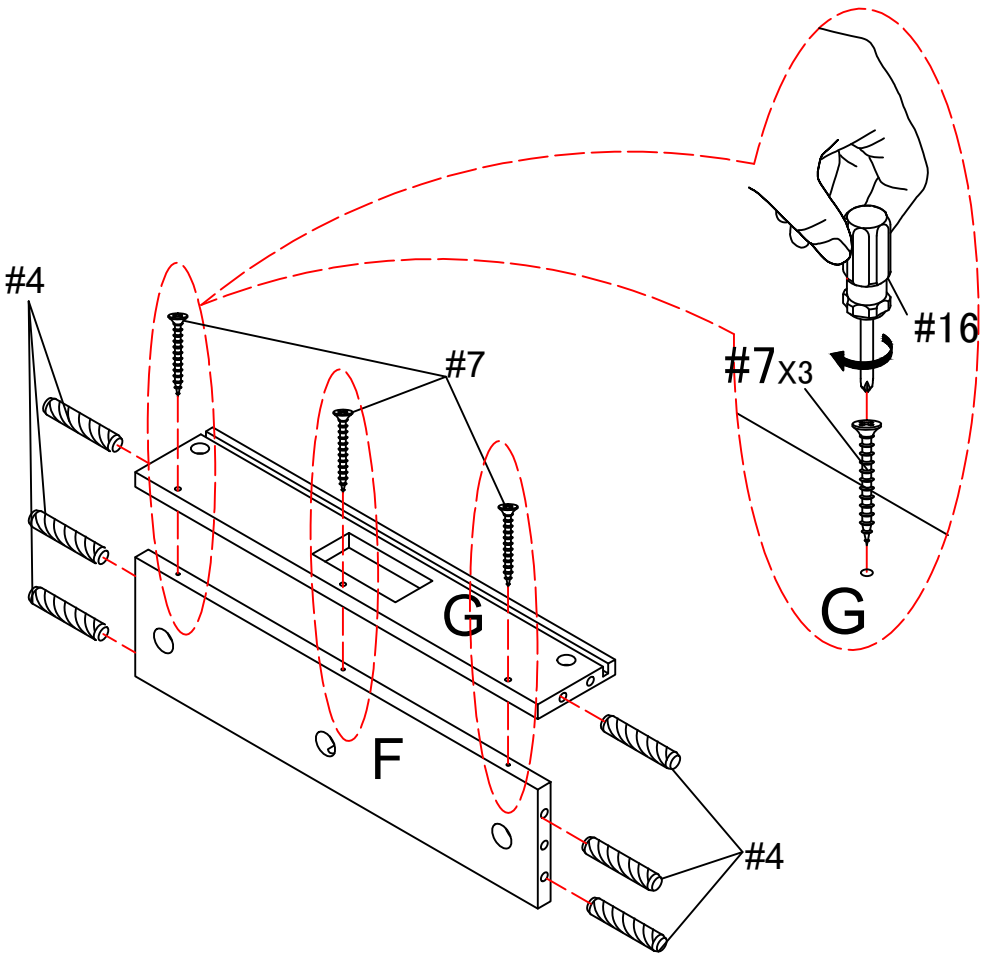

#16	x1
	

#4	x6
	
Ø8*30mm	

#7	x3
	
Ø4*35mm	

ASSEMBLY INSTRUCTIONS

STEP-7

Insert bolt #1 into the corresponding hole of side panels (C&D), tighten bolt #1 with screwdriver #16.

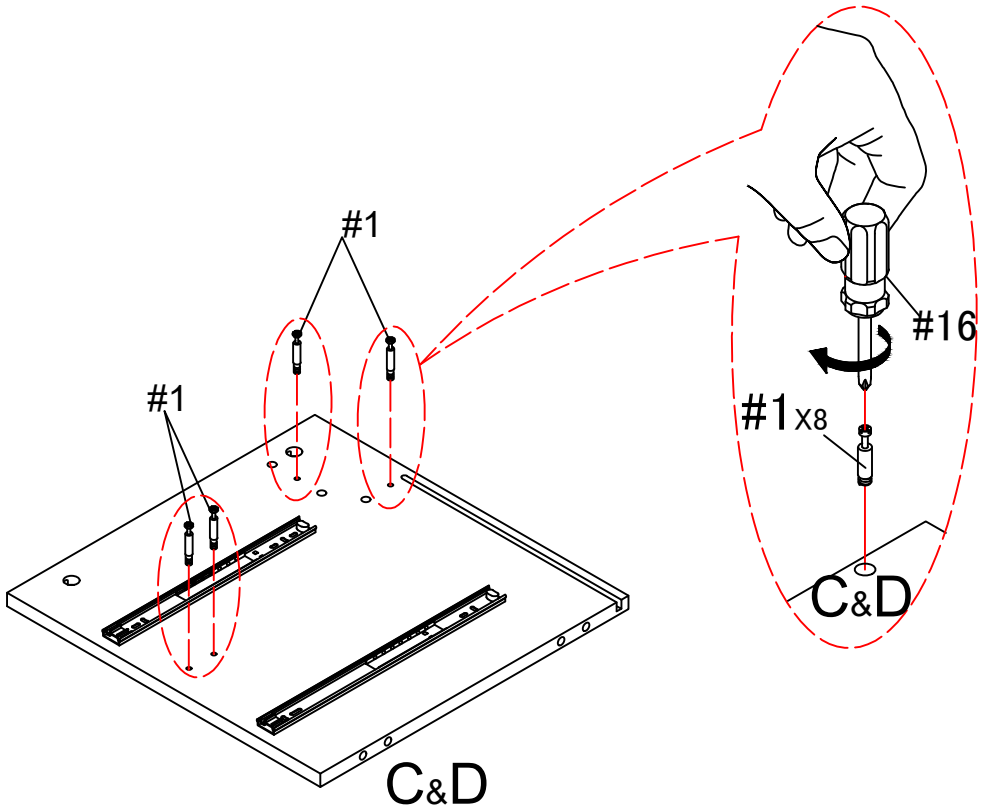

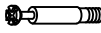

#16	x1	#1	x8
			
		M6*35mm	

ASSEMBLY INSTRUCTIONS

STEP-8

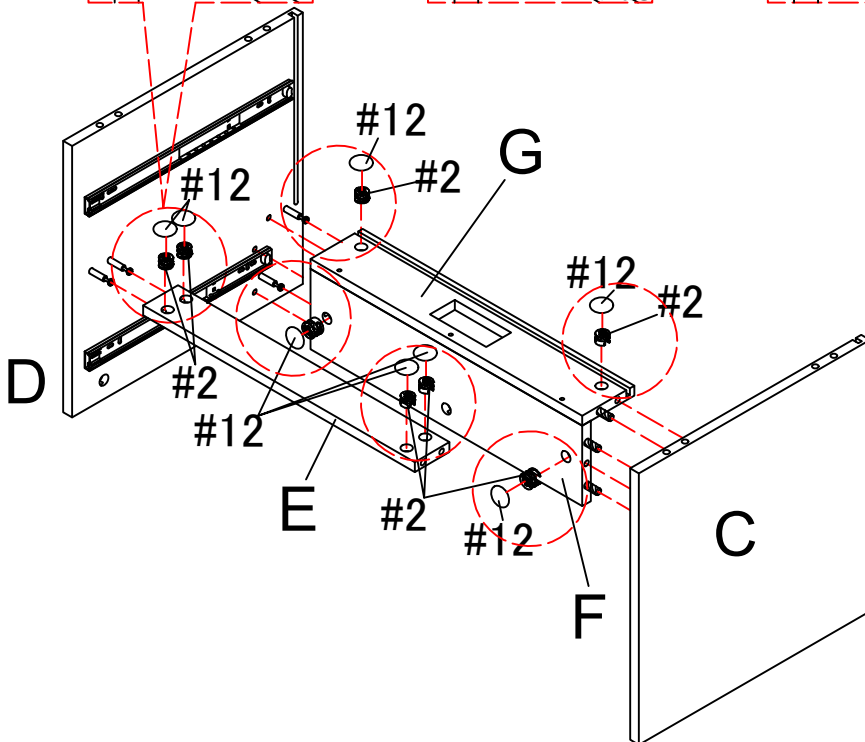
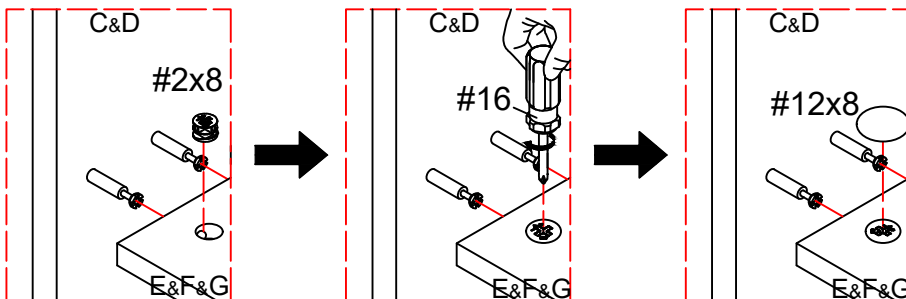
Insert the panels (G&F&E) into the side panels (C&D), make sure all holes aligned and insert cam bolt #2 into the corresponding hole of panel (G&F&E), tighten cam bolt #2 with screwdriver #16. after installation, cover the screw holes with #12.



#16	x1
	

#2	x8
	
Ø15mm	

#12	x8
	

ASSEMBLY INSTRUCTIONS

STEP-9

Slide in the part (H) into the groove in part (C&D) . make sure they are also in groove in part (G).And insert wooden pin #4 to side panel (C&D) by hand.

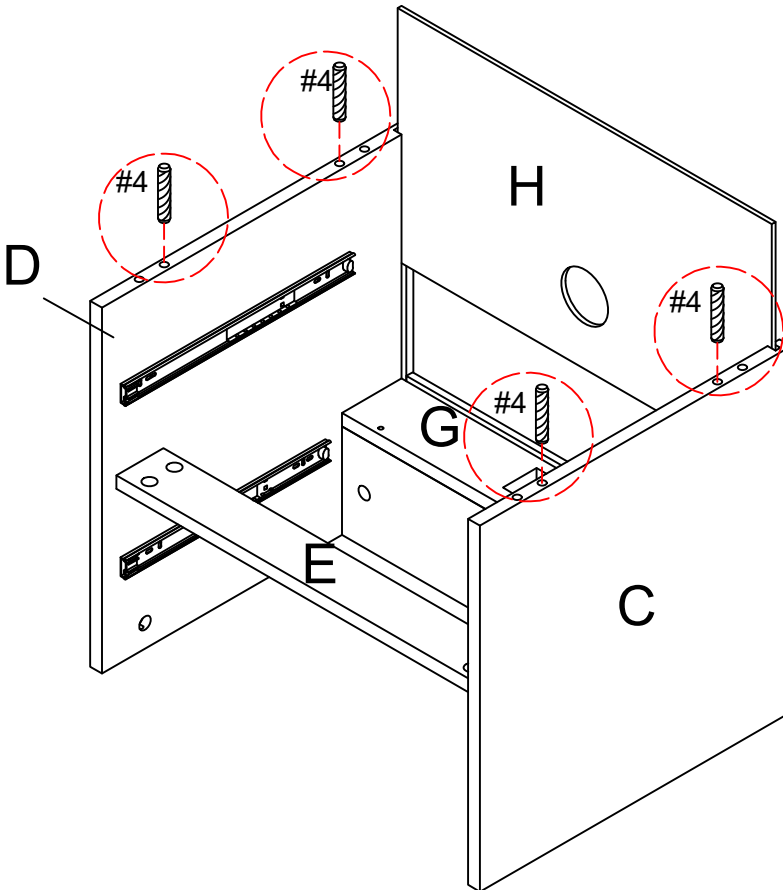



#4	x4
	
Ø8*30mm	

ASSEMBLY INSTRUCTIONS

STEP-10

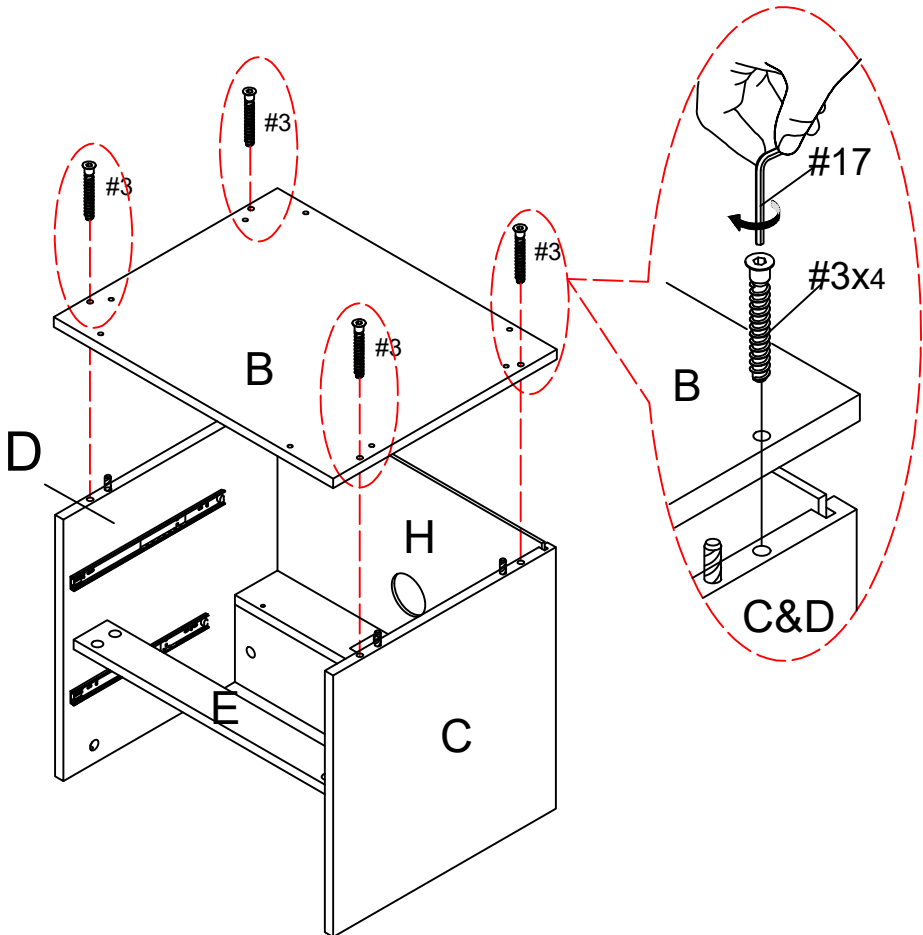
Then align the holes in part B, Insert screw #3 and push it down so that it connects to parts (C&D&H), and tighten the screw #3 with an Allen key #17.



#3	x4
	
M7*50mm	

#17	x1
	
M4	

ASSEMBLY INSTRUCTIONS

STEP-11

Connect the leg frame to the cabinet. Align the hole in the leg frame part (R) to the hole in the part B, tighten bolt #11 with allen key #17.

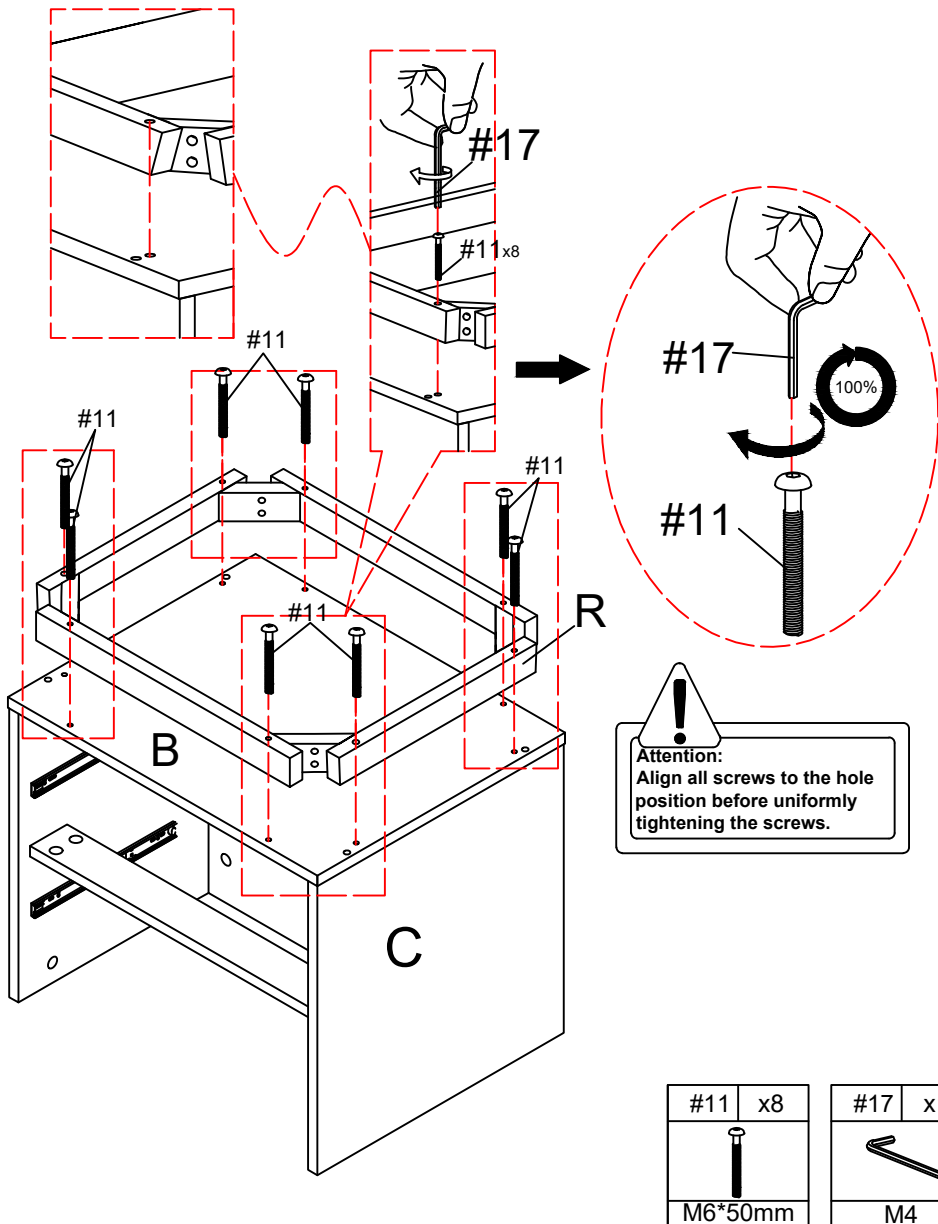



ASSEMBLY INSTRUCTIONS

STEP-12

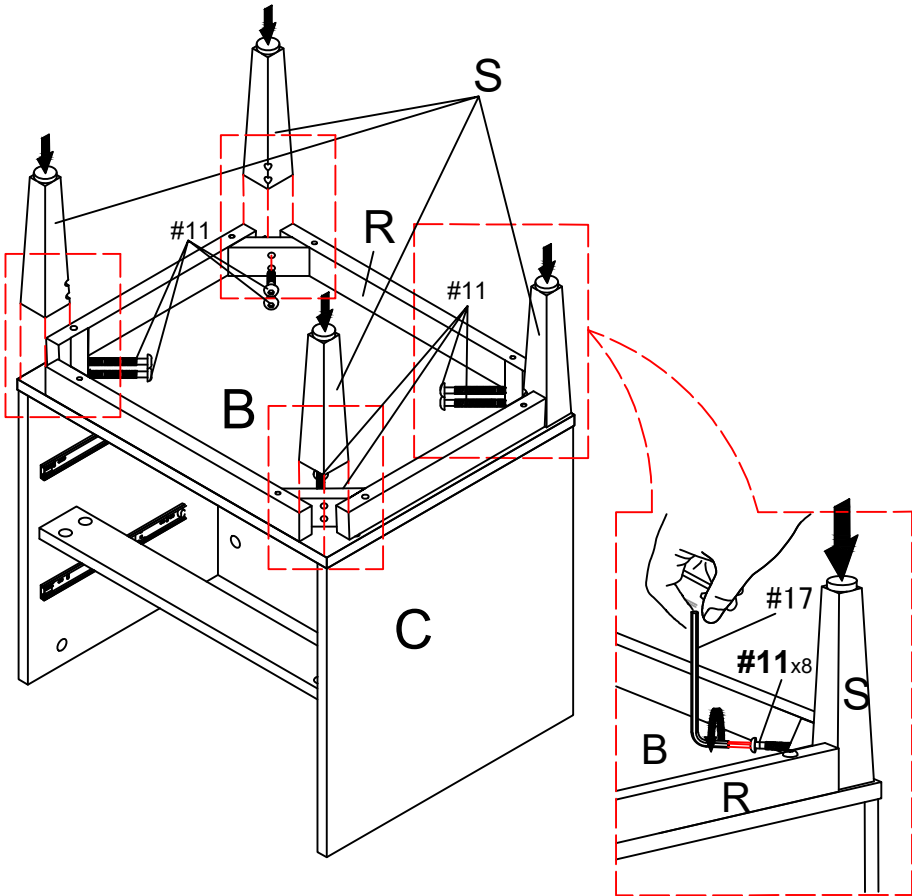
Use bolt #11 to attach leg (R) to the corresponding hole of part (B) as picture show, tighten bolt #11 with allen key #17.



#11	x8
	
M6*50mm	

#17	x1
	
M4	

ASSEMBLY INSTRUCTIONS

STEP-13

Attention:

Before the next step, adjust the feet of the locker to keep it level.

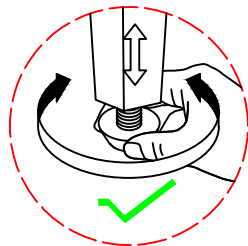
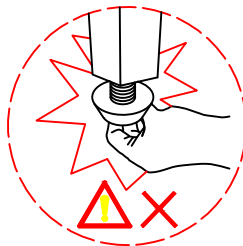
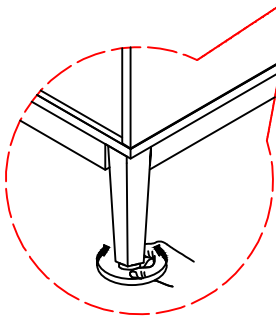
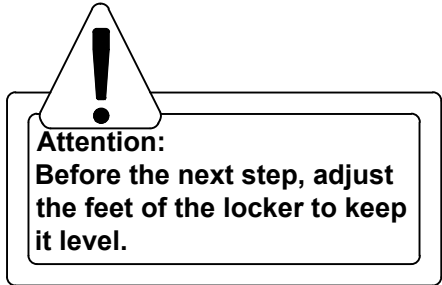
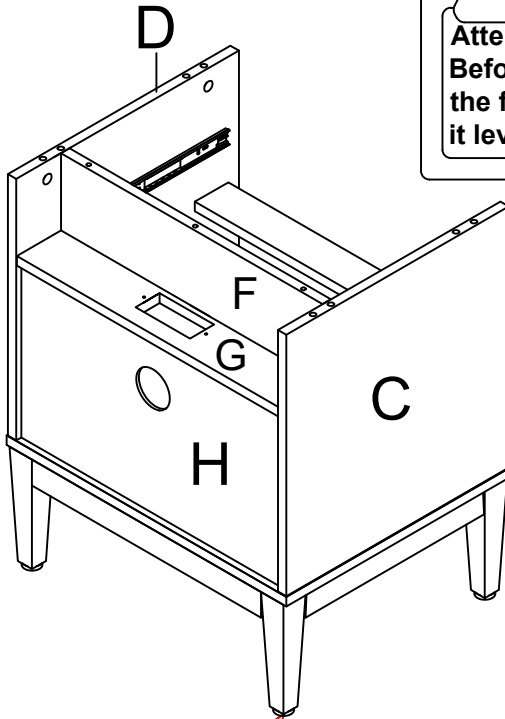



ASSEMBLY INSTRUCTIONS

STEP-14

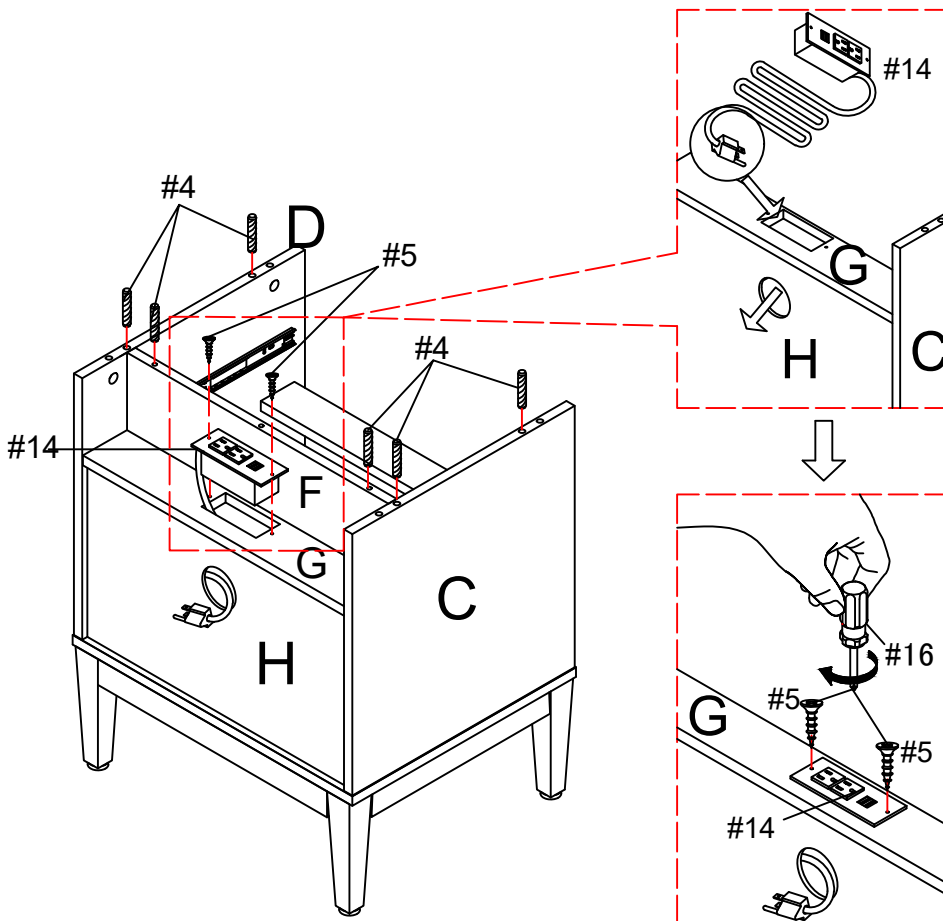
Insert wooden pin #4 to side panel (C&D&F) by hand. Connect socket #14 to part G using screw #5. and tighten it with screwdriver #16.



#16	x1
	

#4	x6
	
Ø8*30mm	

#5	x2
	
Ø3.5*14mm	

#14	x1
	

ASSEMBLY INSTRUCTIONS

STEP-15

Insert bolt #1 into the corresponding hole of top panel (A), tighten bolt #1 with screwdriver #16.

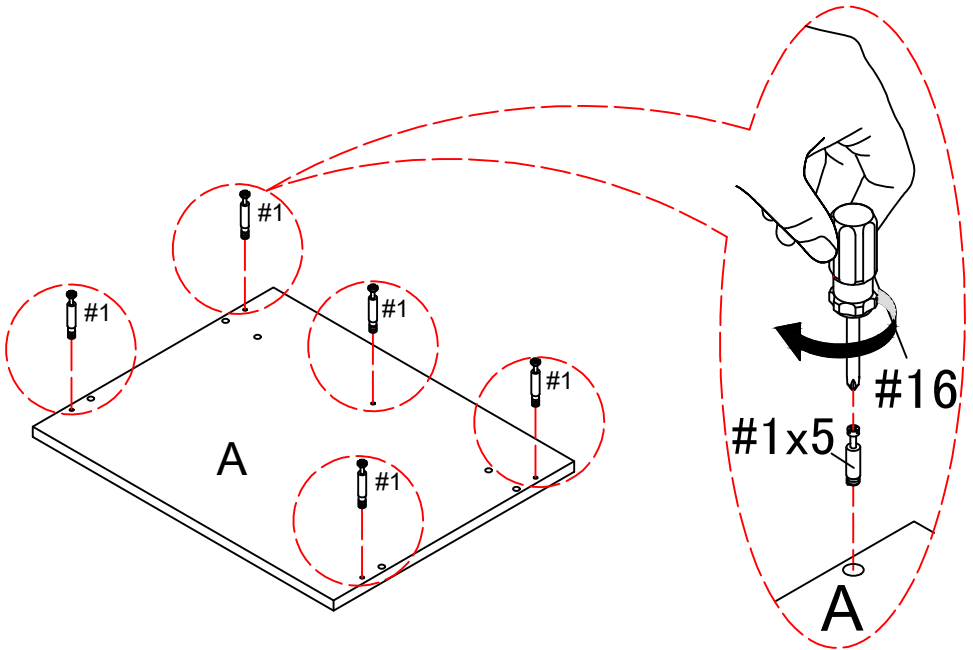

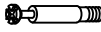

#16	x1	#1	x5
			
		M6*35mm	

ASSEMBLY INSTRUCTIONS

STEP-16

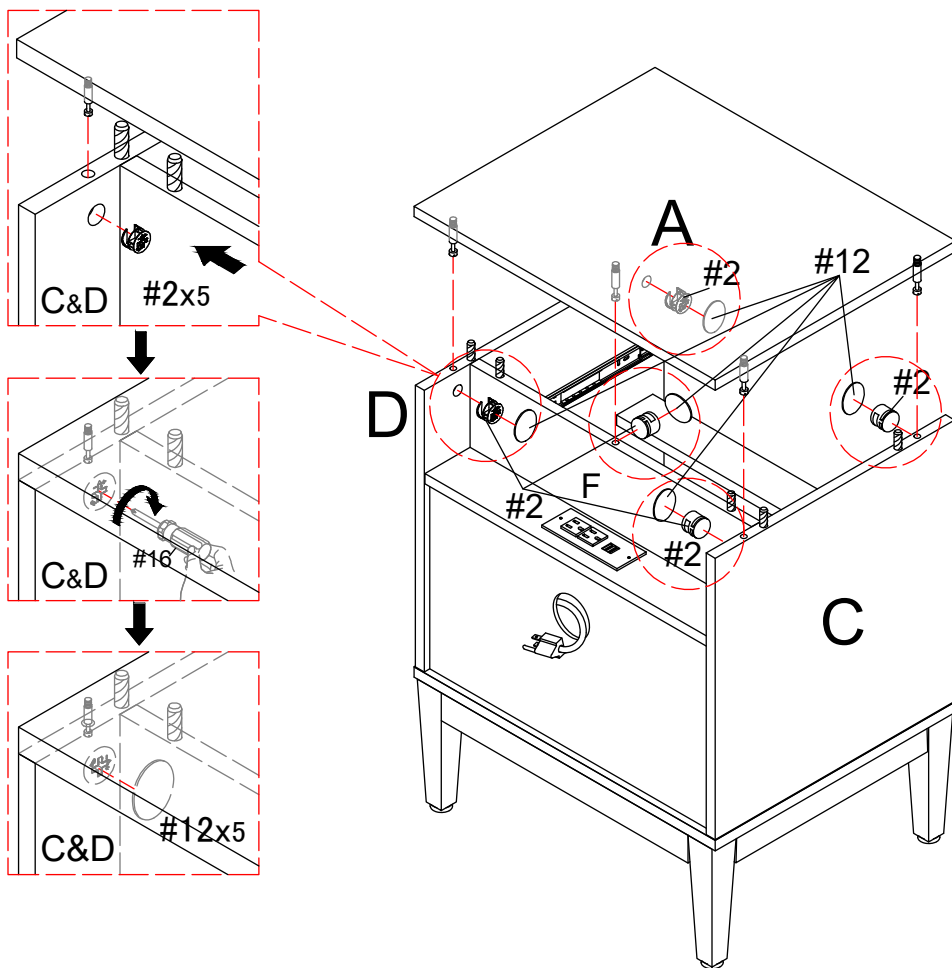
Insert the top panel (A) into the side panels (C&D&F), make sure all holes aligned and insert cam bolt #2 into the corresponding hole of panel (C&D&F), tighten cam bolt #2 with screwdriver #16. after installation, cover the screw holes with #12.



#16	x1
	

#12	x5
	

#2	x5
	
Ø15mm	

ASSEMBLY INSTRUCTIONS

STEP-17

Use screw #5 to attach plastic bracket #13 to panel (A), make sure all holes aligned and tighten screw #5 with screwdriver #16. Insert hardware #6 into part (H) as shown, screw in screw #5 using screwdriver #16 and tighten fully.

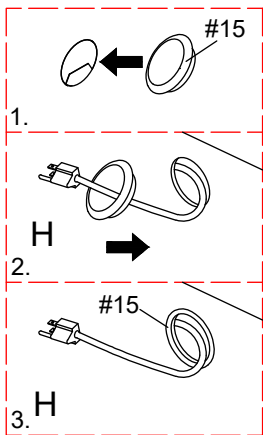
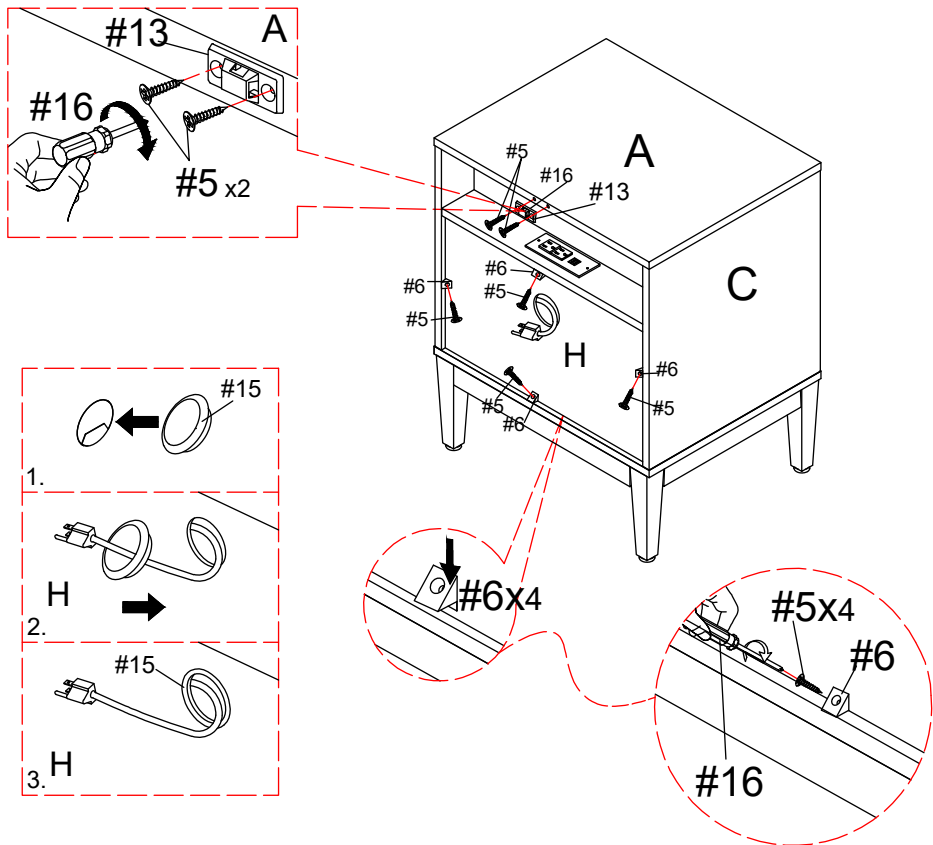

#15	x1

#16	x1

#13	x1

#5	x6
Ø3.5*14mm	

#6	x4

ASSEMBLY INSTRUCTIONS

STEP-18

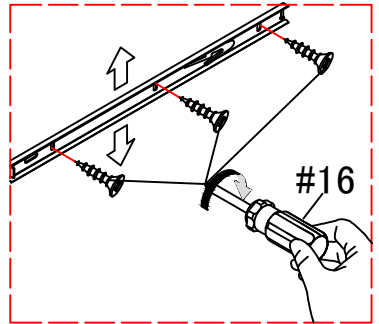
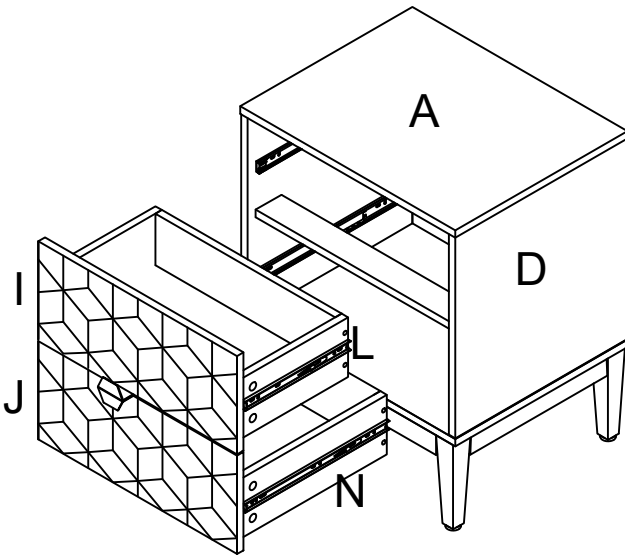

Slide rail adjustment
legend !!!

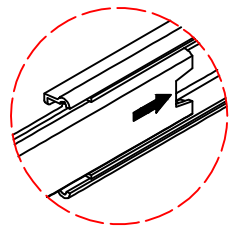
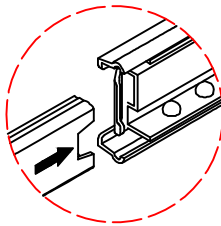
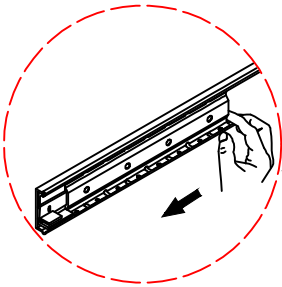

ASSEMBLY INSTRUCTIONS

STEP-19

Mark the position on the wall, that corresponds to the location of part #13 on the top panel A; Drill and insert the expandable screw #9 by hammer.



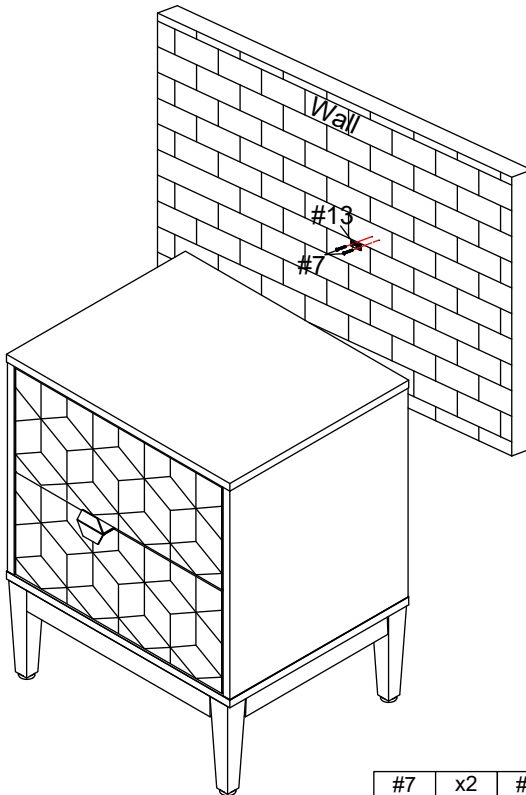

Assemble the part #13 to the wall. Align the hole in the part #13 with the expandable screw #9, use screw #7 to attach it and tighten by screwdriver 16.

Let the plastic belt #8 pass through the both part #13 and pull tightly.

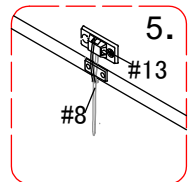
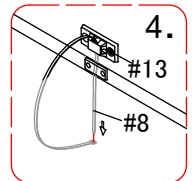
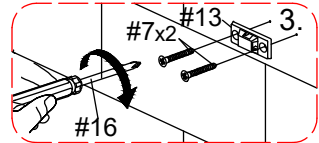
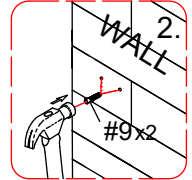
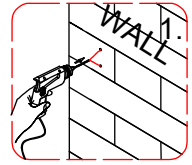

NOT PROVIDED

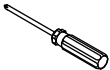

#7	x2	#8	x1	#9	x2	#13	x1	#16	x1
									
M4x35mm									

WARRANTY

1. We strive to offer high-quality products, and we also try our best to satisfy each and every customer that orders from us with product or service as needed.
2. We provide 30 days warranty starting from the time you receive the item. Each customer must provide a record of their order such as the order number, or item receipt for any items that are out of the warranty period you may also still receive.
3. Replacement parts by purchasing them with our company if they are available.