

Balance Shower Faucet Installation Manual

W-242(ES)

Warranty Duration

All components of this faucet system are covered under a lifetime limited warranty, ensuring they are free from defects in material and workmanship for the original purchaser.

Repair and Replacement

If the product shows defects in material or workmanship under normal use and within the warranty period, we will, at our discretion, either repair the product or provide a replacement at no cost to the original purchaser. Please note that proof of purchase (e.g., an invoice) is required when requesting service. The warranty does not cover damages caused by improper installation, misuse, or modifications.

Exclusions

We shall not be responsible for the following cases:

- Damage to the product caused by improper installation, misuse, unauthorized repair or replacement, or abuse (including damage during shipment).
- Damage to the product caused by improper dismantling after installation.
- Damage resulting from abnormal water pressure or impurities in water pipes, which is not covered under this warranty.
- Rust on the product due to insufficient care and maintenance, which is not covered under this warranty.
- Damage caused by natural disasters such as fire, flood, earthquake, lightning storms, etc., which is not covered under this warranty.

I hope this helps! If you have any further questions or concerns, please let me know.

Having Trouble? Contact us.

✉ Email: info@faucetsupport.com

☎ Toll Free: 1-888-969-6880



CEC **F[©]** **C** **€** **RoHS**



M6393-10
SFS-1035

CONTENT

Balance Shower Faucet Installation Manual ----- (1-6)

CONTENIDO

Manual de Instalación del Grifo de Ducha de Balance ----- (7-12)

◆ Installation and Maintenance Matters

1. Check the accessories list to verify that all parts are complete in this package.
2. Do not disassemble the main body by yourself.
3. Connect inlet pipes to supply valves.
4. Make sure inlet pipes and supply valves have no impurities and are cleaned, with no impurities in the pipeline.
5. After installation, check all joints for leakages.
6. Do not leave the rain shower system exposed to a severely corrosive environment.

Do's

1. In order to keep the mixer surface bright, please clean the mixer regularly.
2. Rinse the faucet with clean water and wipe it with a soft cotton cloth.
3. Use one of the following cleaners to remove dirt from the surface:
 - a. Mild liquid cleaner.
 - b. Colorless glass cleaner and powder cleaner that do not cause abrasion and can be dissolved completely.
 - c. Polish liquid that does not cause abrasion.

Don'ts

1. Avoid using cleaning powder, harsh cleaning chemicals, brushes and coarse cloth to prevent scratching and friction.
2. Do not use acid cleaners to clean the faucet as they may cause surface corrosion of the faucet. If the faucet is exposed to harmful acid substances, please rinse it immediately with water.

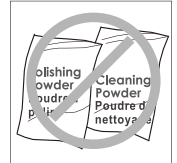
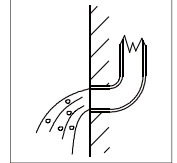
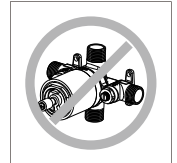

Tools Needed:

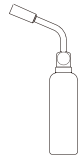
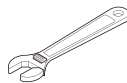
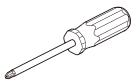

◆ 2-Function Rain Shower Faucet Set Accessories List

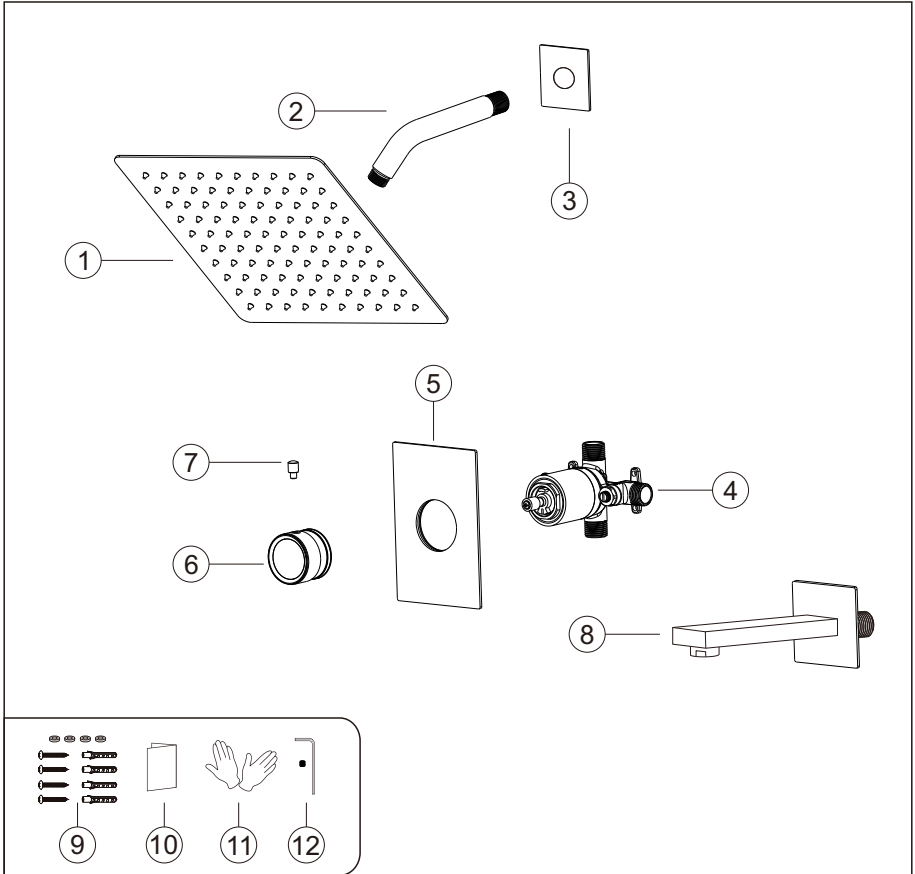

| No. | Part name | Qty | No. | Part name | Qty |
|-----|----------------|-----|-----|-----------------------|-----|
| 1 | Shower head | 1 | 7 | Handle cap | 1 |
| 2 | Shower arm | 1 | 8 | Bathtub spout | 1 |
| 3 | Shower arm cup | 1 | 9 | Main body spare parts | 4 |
| 4 | Main body | 1 | 10 | Instruction manual | 1 |
| 5 | Deck plate | 1 | 11 | Gloves | 2 |
| 6 | Handle | 1 | 12 | Handle parts | 1 |

◆ Essential Dimensions & Water Pipe Lines

Unit: mm/inch

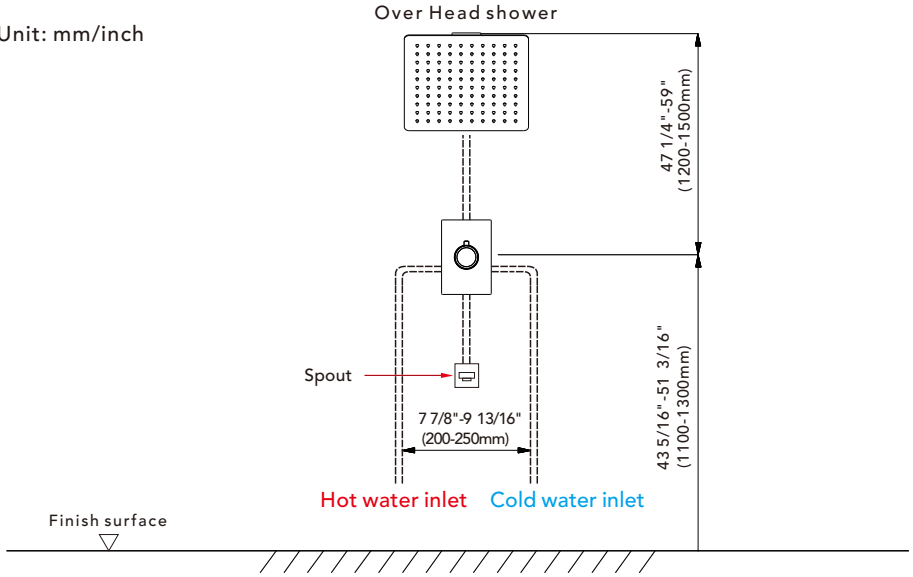

◆ Installation Depth of the Shower Arm and Spout

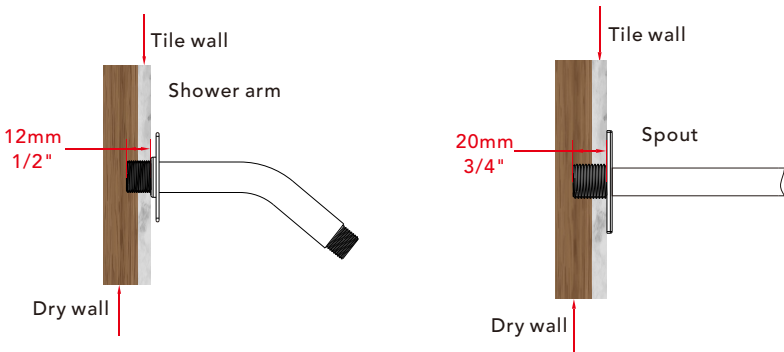

The thickness of the tile must be calculated for installation.

Connector size of male thread: USA: $1/2'' - 14\text{NPT}$, Canada: $1/2'' - 14\text{NPT}$, Europe: $G1/2''$.

◆ Installation Depth of the Main Body

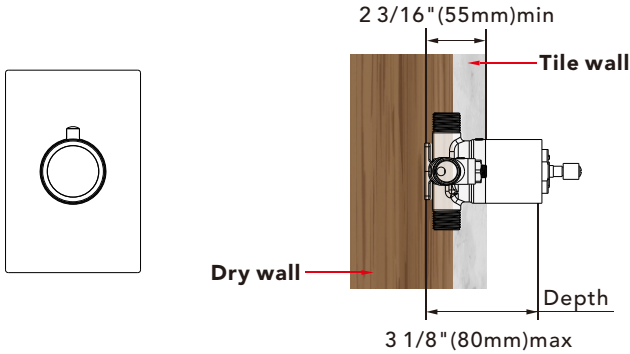

- Notice: 1. The installation depth of the main body should be no less than $2 \frac{3}{16}$ " (55mm) and no more than $3 \frac{1}{8}$ " (80mm), including the thickness of the tile. Otherwise, the deck plate cannot be installed.
2. The opening size of ceramic tile shall be smaller than the deck plate size.

◆ Piping Instructions before Tiling

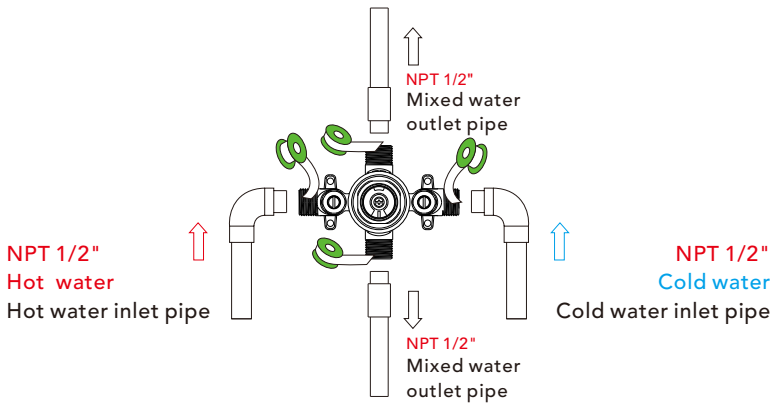

1. As shown in the figure, the inlet and outlet pipes are pre-buried. Please pay attention to the correct direction when installing the pre-buried main body.
2. Before tiling, turn on the water to test whether the left and right inlet pipes are tightly connected without leakage. Then, adjust the flow switch to the "on" position to check for leaks in the mixed outlet pipes.

◆ Main Body Valve Installation

Step1

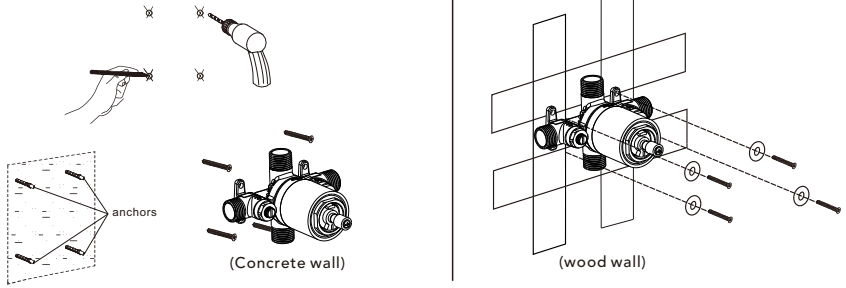

1. Make marks according to the size of the main body valve, and then drill anchors into the wall (concrete wall).
 2. Lock the main body to wood directly with screws (wood wall).
 3. When installing the main body, please mark the UP side up and do not install it upside down.
- ▲ Please note that the level meter should be parallel to the wall; otherwise, the deck plate cannot be installed.

Step2

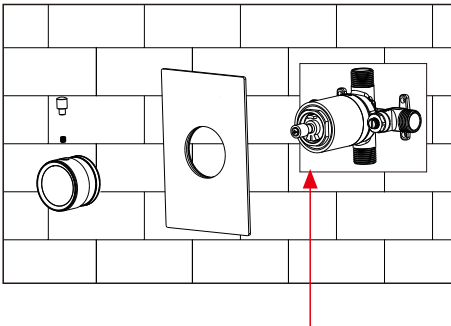

Do not remove the white wear ring; otherwise, the handwheel will be damaged.

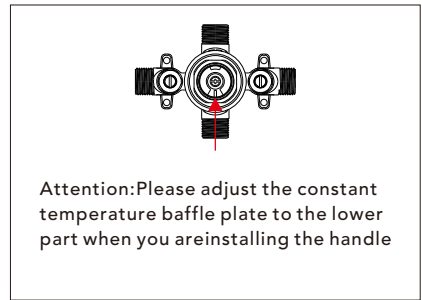

Attention: Please adjust the constant temperature baffle plate to the lower part when you are installing the handle

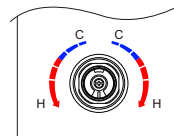

Precautions for handwheel installation

1. Use Main body spare parts and to fixed Main body on the wall and then install deck plate.
2. Please fix the main body to the wall install deck plate ,water diverter screw and water diverter cap step by step.
3. Install the handle with the screw and handle cap.

◆ Shower Head Installation

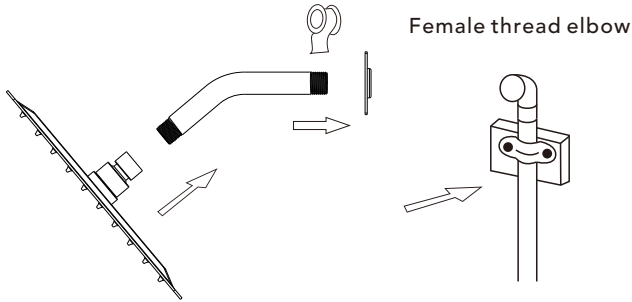

1. Connect shower arm with the cover before screwing arm into riser connection to prevent damage.
2. Fix shower head onto shower arm and apply tape to pipe threads on both ends.
3. Do not over tighten shower head. It is 360° swivel connection.

◆ Tub Spout Installation

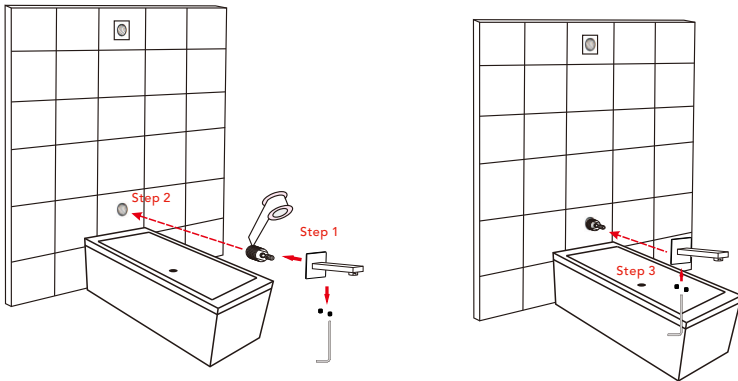

- Step1: Loosen the two screws below the water outlet tap and remove the connector. Wrap the connector with PTFE tape.
- Step2: place it into the pre-drilled hole in the wall, and tighten it using a hex screwdriver.
- Step3: Insert the end of the water outlet tap into the connector that is already installed in the wall, and retighten the two screws. Make sure to keep the outlet facing directly downward.

◆ Instalación y Cuestiones de Mantenimiento

1. Verifique la lista de accesorios para comprobar que todas las partes están completas en este paquete.
2. No desmonte el cuerpo principal por sí mismo.
3. Conecte las tuberías de entrada a las válvulas de suministro.
4. Asegúrese de que las tuberías de entrada y las válvulas de suministro no tengan impurezas y estén limpias, sin impurezas en la tubería.
5. Después de la instalación, verifique todas las uniones para detectar fugas.
6. No deje el sistema de ducha tipo lluvia expuesto a un entorno altamente corrosivo.

Hacer

1. En para mantener la superficie de la batidora brillante, limpie el mezclador regularmente.
2. Inse el grifo con agua limpia y límpielo con un suave ropa de algodón.
3. Utilice uno de los siguientes limpiadores para eliminar la suciedad de la superficie:
 - a. Limpiador líquido suave.
 - b. Limpiador de vidrio incoloro y limpiador en polvo que no causen abrasión y que se puedan disolver completamente.
 - c. Líquido pulidor que no cause abrasión.

No hacer

1. Valte con polvo de limpieza, productos químicos de limpieza duros, cepillos y tela gruesa para evitar rascar y fricción.
2. No use limpiadores de ácidos para limpiar el grifo, ya que pueden causar corrosión superficial del grifo. Si el grifo está expuesto a sustancias ácidas dañinas, enjuague inmediatamente con agua.

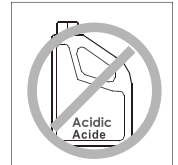
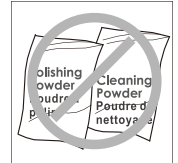
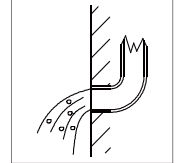
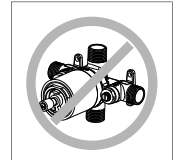

Herramientas Necesarias:

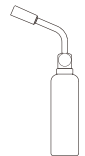
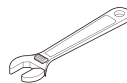
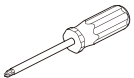

◆ Juego de Grifo de Ducha de Lluvia de 2 Funciones

Lista de Accesorios

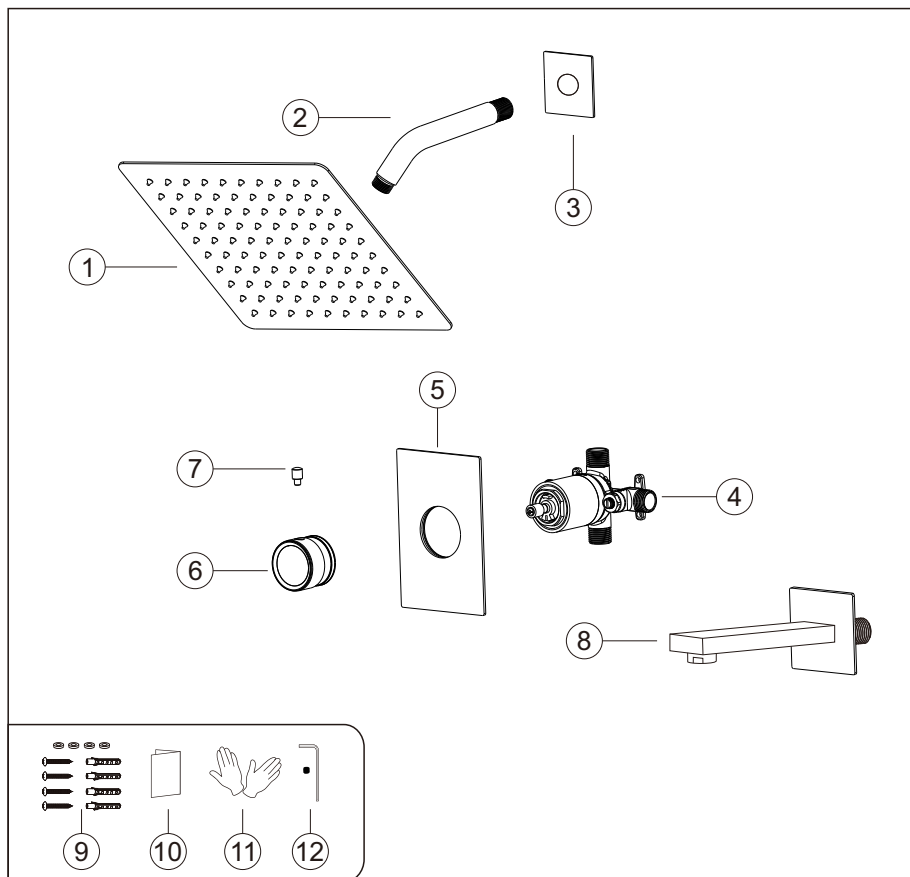

| N.º | Nombre de la pieza | Cant. | N.º | Nombre de la pieza | Cant. |
|-----|-------------------------|-------|-----|---|-------|
| 1 | Cabezal de ducha | 1 | 7 | Tapa de la manija | 1 |
| 2 | Brazo de ducha | 1 | 8 | Salida de bañera | 1 |
| 3 | Copa del brazo de ducha | 1 | 9 | Piezas de repuesto del cuerpo principal | 4 |
| 4 | Cuerpo principal | 1 | 10 | Manual de instrucciones | 1 |
| 5 | Placa de cubierta | 1 | 11 | Guantes | 2 |
| 6 | Manija | 1 | 12 | Piezas de la manija | 1 |

◆ Dimensiones Esenciales y Líneas de Tubería de Agua

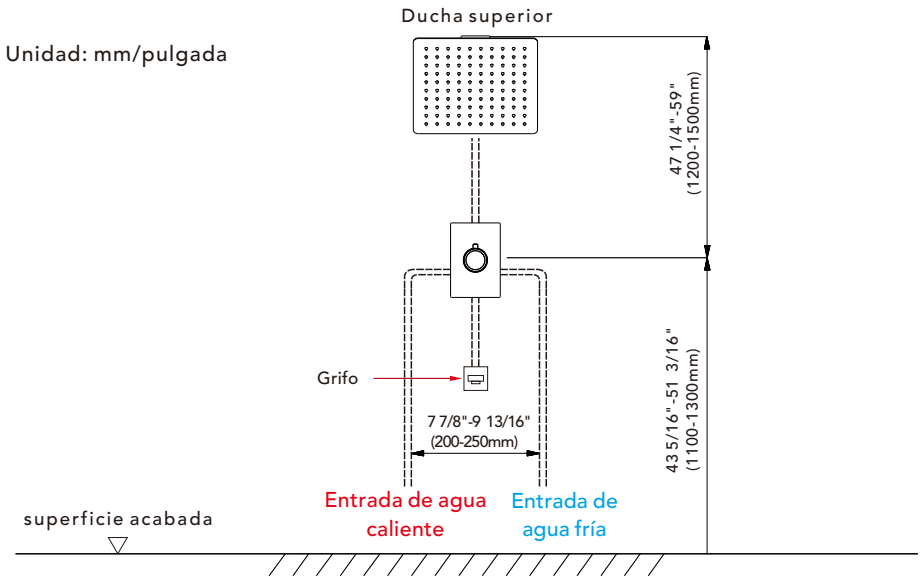

◆ Profundidad de Instalación del Brazo de Ducha y la Boquilla

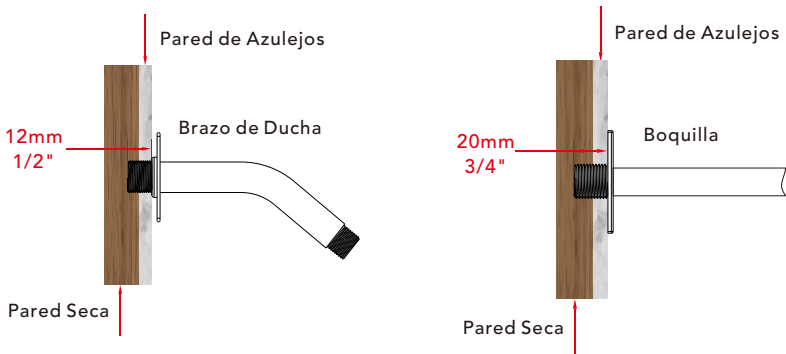

El grosor del azulejo debe ser calculado para la instalación.

Tamaño del conector de rosca macho: EE. UU.: 1/2"-14NPT, Canadá: 1/2"-14NPT, Europa: G1/2".

◆ Profundidad de Instalación del Cuerpo Principal

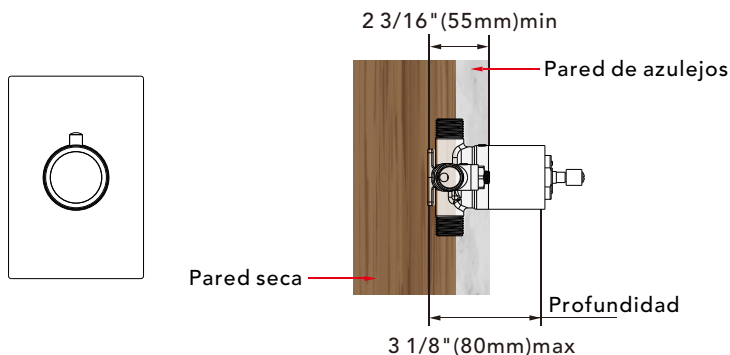

Aviso: 1. La profundidad de instalación del cuerpo principal no debe ser inferior a 2 3/16" (55 mm) y no más de 3 1/8" (80 mm), incluyendo el grosor del azulejo. De lo contrario, la placa de cubierta no podrá ser instalada.

2. El tamaño de apertura del azulejo cerámico debe ser menor que el tamaño de la placa de cubierta.

◆ Instrucciones de Tuberías antes del Alicatado

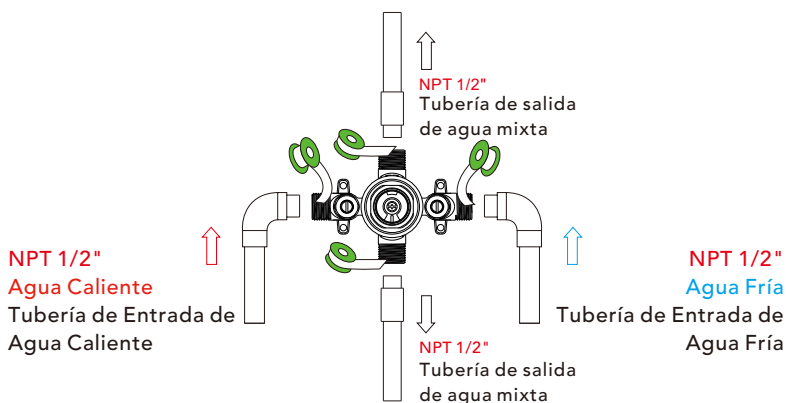

1. Como se muestra en la figura, las tuberías de entrada y salida están pre-enterradas. Por favor, preste atención a la dirección correcta al instalar el cuerpo principal pre-enterrado.

2. Antes de colocar los azulejos, abra el agua para probar si las tuberías de entrada izquierda y derecha están conectadas herméticamente sin fugas. Luego, ajuste el interruptor de flujo a la posición "on" para comprobar si hay fugas en las tuberías de salida mezcladas.

◆ Instalación de la Válvula del Cuerpo Principal

Paso 1

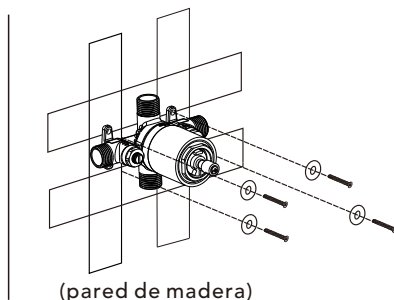
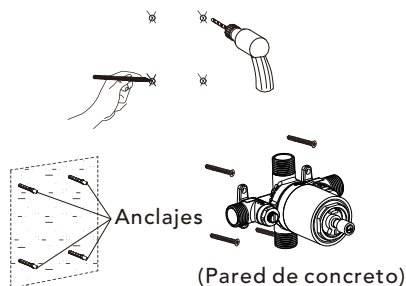

1. Marque según el tamaño de la válvula del cuerpo principal y luego perforo para colocar los anclajes en la pared (pared de concreto).
 2. Fije directamente el cuerpo principal a la madera con tornillos (pared de madera).
 3. Al instalar el cuerpo principal, por favor marque el lado UP hacia arriba y no lo instale al revés.
- ▲ Tenga en cuenta que el nivel debe estar paralelo a la pared; de lo contrario, la placa de cubierta no podrá ser instalada.

Paso 2

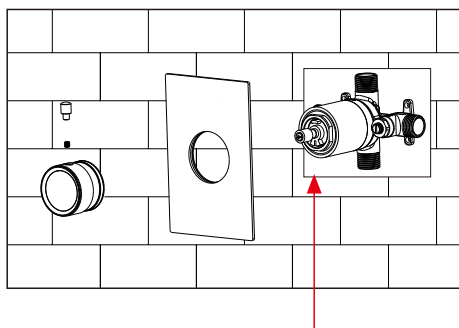

No retire el anillo blanco de desgaste; de lo contrario, la rueda manual se dañará.

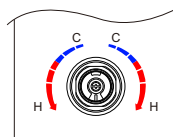

Precauciones para la instalación de la rueda manual

1. Use las piezas de repuesto del cuerpo principal para fijar el cuerpo principal en la pared y luego instale la placa de cubierta.
2. Por favor, fije el cuerpo principal a la pared e instale la placa de cubierta, el tornillo del desviador de agua y la tapa del desviador de agua paso a paso.
3. Instale la manija con el tornillo y la tapa de la manija.

◆ Instalación del Cabezal de Ducha

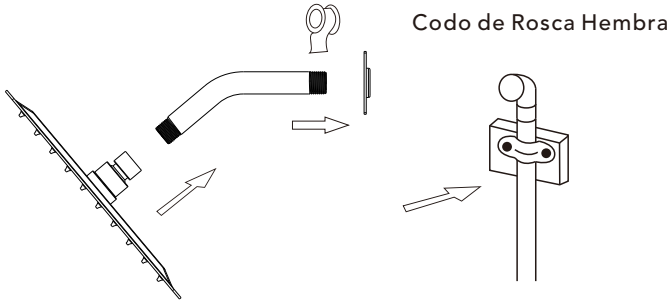

1. Conecte el brazo de la ducha con la cubierta antes de atornillar el brazo en la conexión del elevador para evitar daños.
2. Fije el cabezal de ducha al brazo de ducha y aplique cinta a las roscas de la tubería en ambos extremos.
3. No apriete demasiado el cabezal de ducha. Es una conexión giratoria de 360°.

◆ Instalación de la Boquilla de Bañera

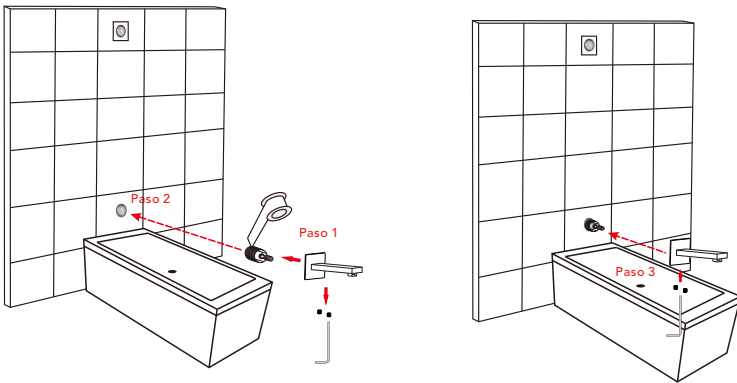

Étape 1 : Desserrez les deux vis sous le robinet de sortie d'eau et retirez le connecteur.
Enveloppez le connecteur avec du ruban PTFE.

Étape 2 : Placez le connecteur dans le trou préalablement percé dans le mur et fixez-le à l'aide d'un tournevis hexagonal.

Étape 3 : Insérez l'extrémité du robinet de sortie d'eau dans le connecteur déjà installé dans le mur et resserrez les deux vis. Assurez-vous que la sortie est orientée directement vers le bas.