

Porch Swing

Tools Needed: #2 Philips or Robertson screwdriver, wood glue and a ½ wrench.

Package Contents:

- (A) Arms...2
- (B) Arm Post...2
- (C) Back Support...3
- (D) Seat Supports...3
- (E) Scalloped Front Rail...1
- (F) Seat Slats...10
- (G) Narrow Top Slat...1

Hardware

- 2 ½" screw...8
- 1 ¾" screw...39
- Carriage bolt...2
- Lag Screw...3
- J - Bolt...4
- Washer...9
- Hex Nut...6
- Chain... (4 pcs)

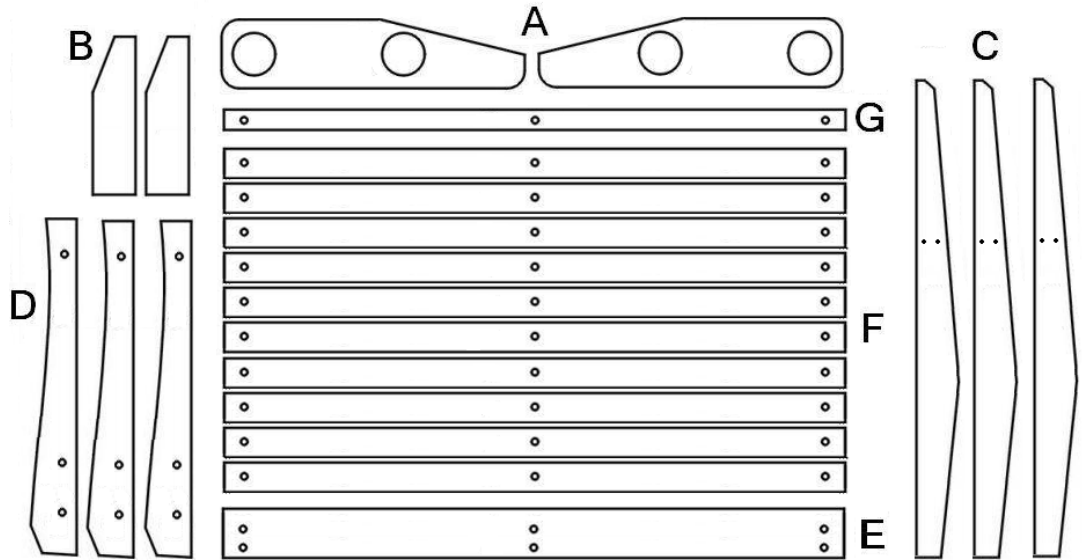

STEP 1. Build Frame

- Align 3 seat supports (D) to be even with bottom of front rail (E) as shown, Attach using 1-3/4 inch screws.

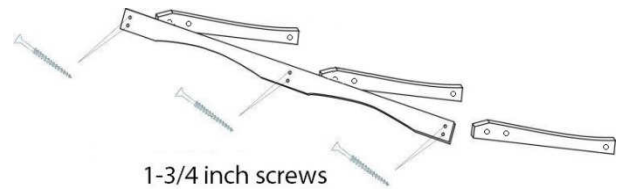

STEP 2. Attach Seat Slats

- Beginning from front of seat evenly space 5 seat slats across the seat supports and attach using 1 ¾ inch screws.

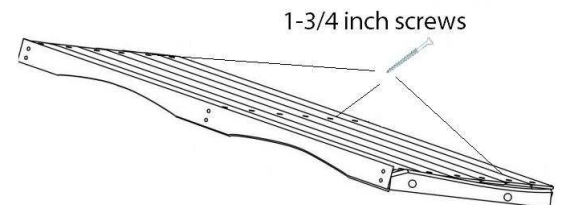

STEP 3. Attach Back Supports

- Attach 3 Back Supports (C) to the seat supports using lag screws and washers.

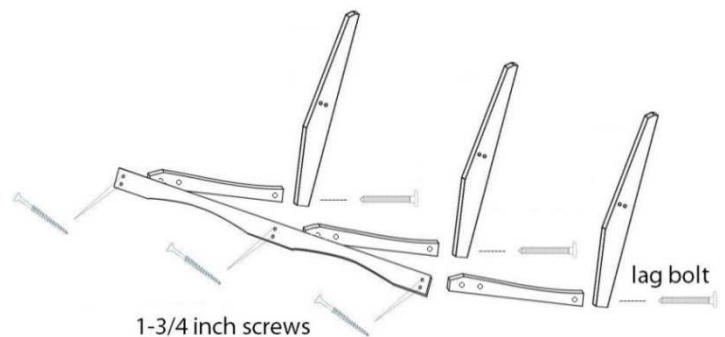

STEP 4. Attach Back Slats

- Tip the swing so it rests on the 3 Back Posts and attach the **narrow top slat (G)** along the top of the swing.
- Evenly space and attach remaining 5 slats to the back supports starting from top slat down.

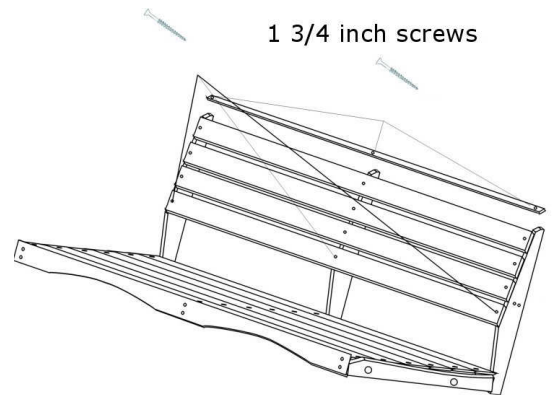

STEP 5. Attach Arms

- Mount Arm post to side of the Swing using Carriage Bolts.
- Set front of arm over arm post and align rear arm with pre-drilled holes in back post - make arm flush with back post and attach arm using 2-1/2 inch screws.
- Make inside of arm flush with arm support and attach arm to arm post using 2-1/2 inch screws. (glue is optional here)

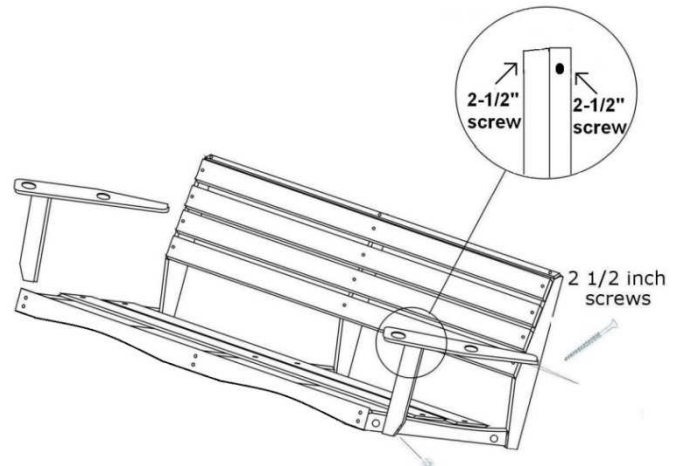

STEP 6. Hardware Placement

NOTE: If you hanging distance is higher than 8 ft. you may require additional chain.

- Attach 2 pieces of chain to each side of your roof beam or A-Frame. (space 50 inches apart)
- Use washers and hex nuts to install J-Bolts to the pre-drilled holes located on each side of the swing - leave loose.
- Insert the free ends of each chain through the guide holes on the arm and loop chain onto open end of J-Bolt.
- Tighten J-Bolt until open end of hook is depressed into the wood by about 1/4 inch and until nut is good and tight.
- To create a gentle incline raise the front of the swing by a link or two.
- Your swing is ready for use.

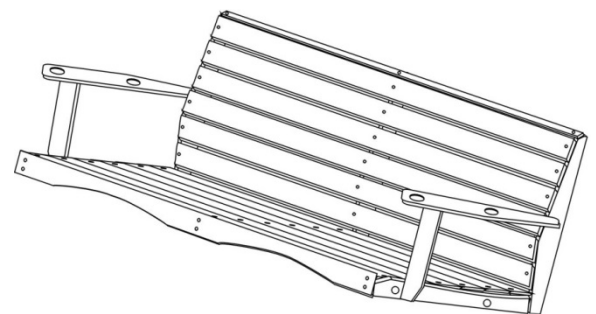

As with all outdoor furniture it is good practice to periodically check tightness of all hardware on your swing.