







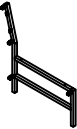
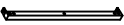

CARE AND MAINTENANCE

Wipe clean with a soft, dry cloth. Test the cleaning method on a hidden area before using them over the entire area.

NOTICE

- * Please make sure that you have all parts indicated before you begin assembly of this item.
- * This item should be assembled on a soft surface to prevent scratching the finished product during assembly.
- * This item may require periodic assembly.
- * Do not tighten bolts until completely assembled.

Part List and Hardware List

PIECE	DESCRIPTION	PICTURE	QUANTITY
A	Side frame (Left)		1x
B	Side frame (Right)		1x
C	Connecting bar (Front)		1x
D	Connecting bar (Back)		3x
E	Back cushion		1x
F	Seat cushion		1x
H1	Allen Bolt	 1/4"x5/8"	18x
H2	Allen Bolt	 1/4"x2"	5x
H3	Allen Bolt	 1/4"x1"	4x
H4	Flat washer	 $\phi 13*1.0*\phi 6.5$	23x
H5	Allen Key	 M4	1x

Product Dimensions: 27-1/2"W*30"D*36"H

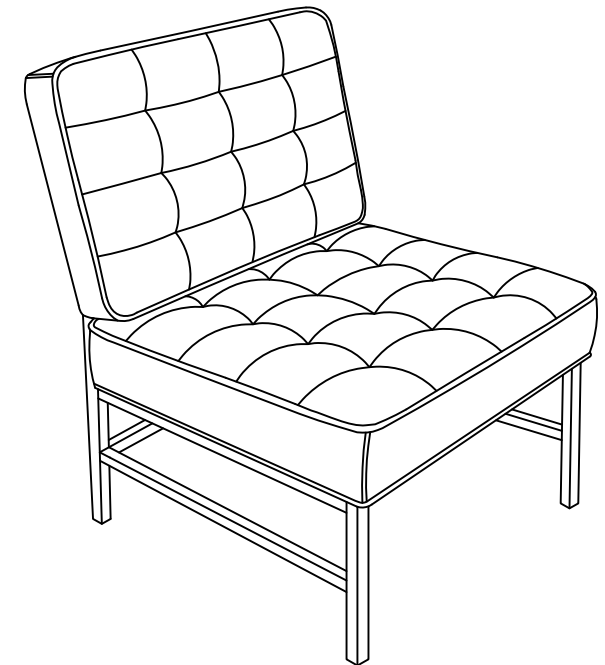

PREPARATION

Before beginning assembly of product, make sure all parts are present. Compare parts with package contents list and hardware contents list. If any part is missing or damaged, do not attempt to assemble the product.

Estimated Assembly Time: 15 minutes.

Tools Required for Assembly (included): Allen Key

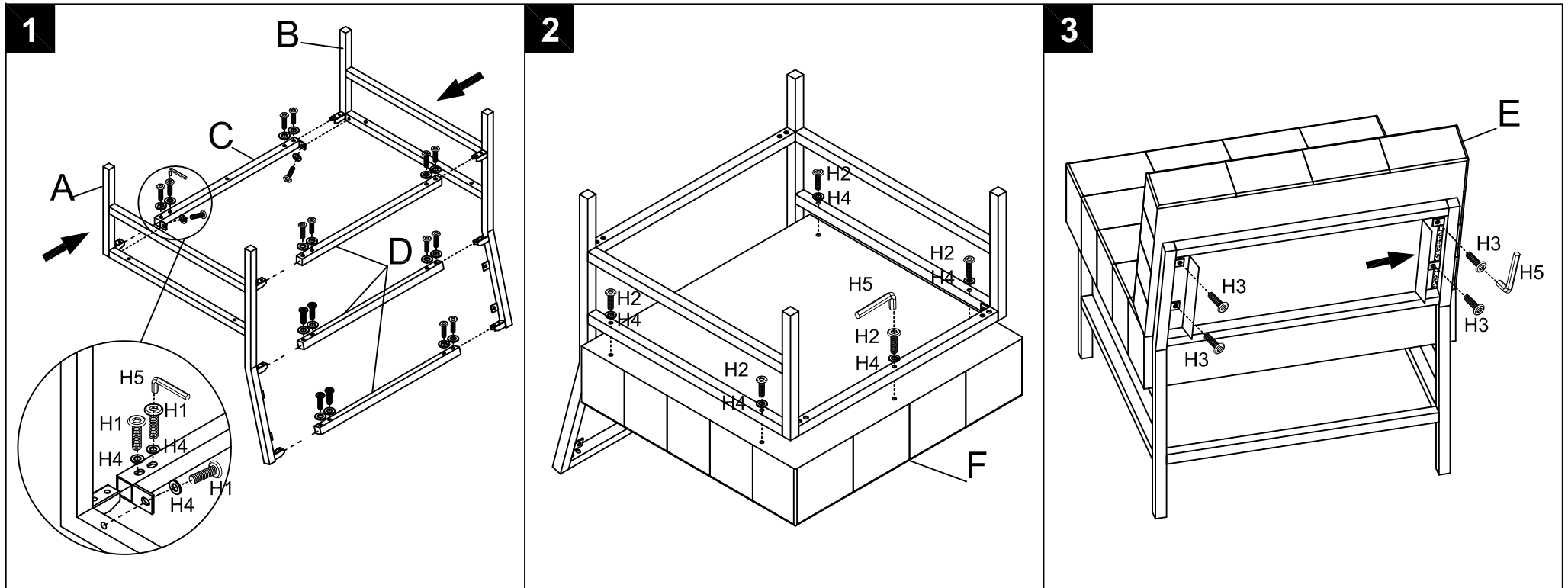

Step 1

Attach 1 connecting bar(Front) "C" and 3 connecting bars(back) "D" to the 2 side frame(Left) "A" and side frame(Right) "B". Use Allen key (H5) to lock through holes on connecting bars with 18 Flat washer (H4) with 18 Allen bolts (H1).

Step 2

Use 5 Flat washer (H4) with 5 Allen bolt (H2) to lock the seat cushion (F) with the assembled metal frame by Allen key (H5).

Step 3

Open the both Left and Right side covering on the back of back cushion (E) then alignment the back cushion with the metal frame and use 4 Allen bolt (H3) to lock the back cushion (E) with the assembled metal frame by Allen key (H5). Then stick the covering well as above picture shown.