

IMPORTANT:

- Mains Voltage: 220 ~ 240V – 50Hz
- This lamp is double insulated (Class II) and does not require an earth connection.

USER ADVICE

- Keep all packaging until after a successful installation and retain instructions for future use
- The design of the lamp may vary slightly from the illustration.

LOCATION:

- Indoor use only
- Ensure the lamp is in a location where the power cable will not cause an accident
- Place lamp on a level surface.

ASSEMBLY:

- Unpack all components onto a flat surface that will not damage them or allow them to become dirty.
- Offer the legs on to the underside of the triangular base plate and secure with the screws provided, repeat until all 3 legs are secured.
- Remove the shade ring.
- Carefully fit the bulb & shade (not included).
- Replace the shade ring

SAFETY:

- Before inserting or replacing bulbs make sure that the light is unplugged and has cooled down.
- Always disconnect from the mains after use & before cleaning or servicing.
- THE EXTERNAL FLEXIBLE CABLE OR CORD OF THIS LUMINAIRE CANNOT BE REPLACED; IF THE CORD IS DAMAGED, THE LUMINAIRE SHALL BE DESTROYED.

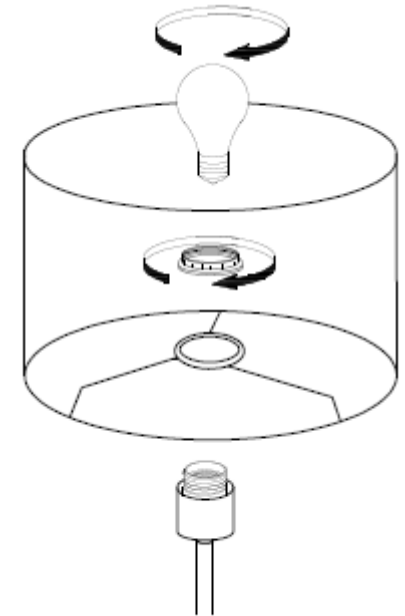
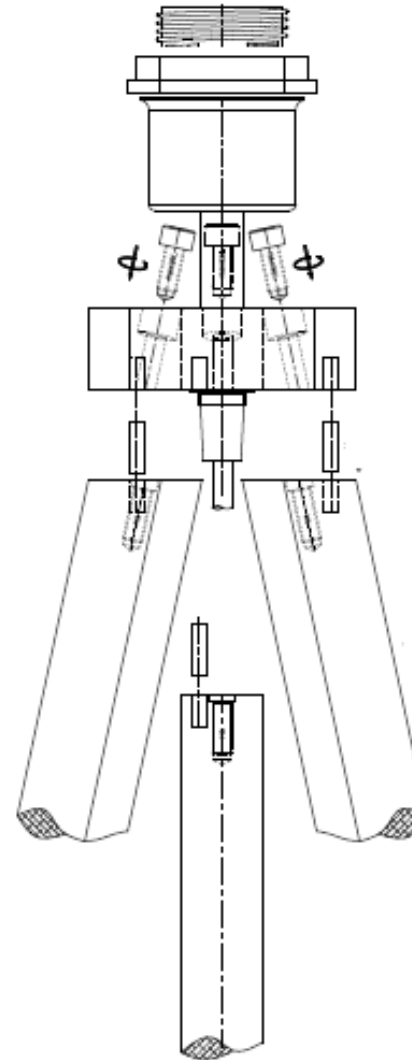

M30 9QG UK
LSE Customer Service:
0161 832 4957