

INSTRUCTION MANUAL

Kids Tent Swing



WARNING:

Adult assembly and supervision required.

This product should be unpacked and assembled by an adult, including site and tree selection.

In unassembled state, it contains potentially hazardous small objects, please keep out of children's reach.

! NOTICE

Please retain these instructions for future reference.

- Adult assembly and installation is required.
- This swing is for household, indoor/outdoor use only.
- Only use with adult supervision. Do not allow children to play alone.
- A maximum of two children are allowed on the swing at a time.
- Do not stand on or use any part of this item as a step ladder.
- Firmly secure all bolts, screws and knobs before use.
- Reconfirm that all bolts, screws, and knobs are secure every 90 days.
- This item is not intended for use by persons with reduced physical, sensory or mental capabilities, or lack of experience and knowledge, unless they have been given supervision or instruction concerning use of the item by a person responsible for their safety.
- If any parts are missing, broken, damaged, or worn, stop using this product until repairs are made and/or factory replacement parts are installed.
- Do not use this item in a way inconsistent with the manufacturer's instructions as this could void the product warranty.

AGE RANGE: 3 years old and up

USER WARNINGS

- Before use, make sure the swing is in good condition and that the hardware/hanging points are secure.
- Do not use swing if equipment is wet.
- Do not swing beyond a 45° angle.
- Do not place anything underneath the swing that could hinder or obstruct the swinging motion.
- Do not attach items to the swing (jump ropes, clotheslines, cables, chains, etc.) as this could be strangulation hazard.
- User must dress appropriately to use swing. Do not wear loose clothing or clothing with cords and drawstrings.
- Remove shoes when using swing.
- Do not jump on the swing or jump into the swing. Step onto the swing carefully.
- Do not jump off the swing.
- Do not walk or stand in the proximity of a moving swing.
- Do not push an empty swing as it may hit a person and cause injury.
- Only sit in the swing; do not stand.
- During use, stay in the center of the swing.
- Maintain control of the swing at all times.
- Do not use if any part of the swing is broken or loose.



TOOLS REQUIRED



SOCKET
WRENCH



3 AA BATTERIES



13MM
SOCKET



PENCIL
& RULER



DRILL



HAMMER



220 LBS
CAPACITY
(COMBINED)



2 PERSON
ASSEMBLY



APPROXIMATELY
30 MIN.
ASSEMBLY

HARDWARE

1

M8 x 60mm
SLEEVE
ANCHOR

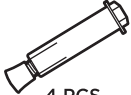

4 PCS

2

MOUNT



1 PC

3

ROPE



1 PC

4

CARABINER



2 PCS

PARTS

A

TENT



1 PC

B

TOP FRAME



3 PCS

C

BOTTOM
FRAME



4 PCS

D

CUSHION



1 PC

E

STRING LIGHTS

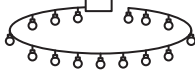

1 PC

PRODUCT ASSEMBLY

1

Slide three part B top frames into the designated sleeves inside the part A tent. Attach the top frames to one another.

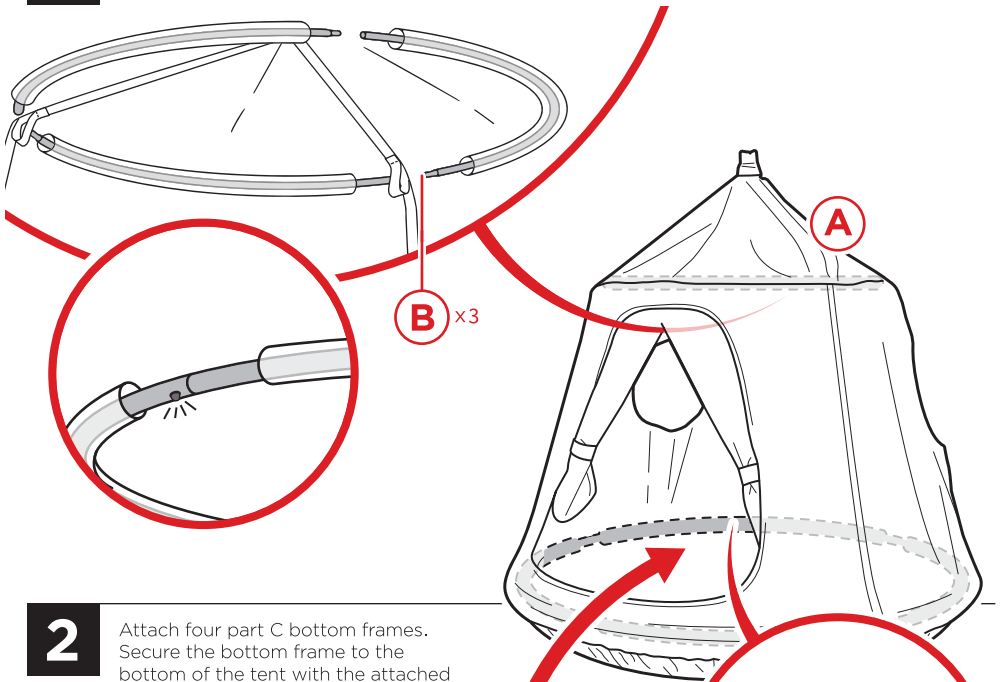

2

Attach four part C bottom frames. Secure the bottom frame to the bottom of the tent with the attached adhesive strips.

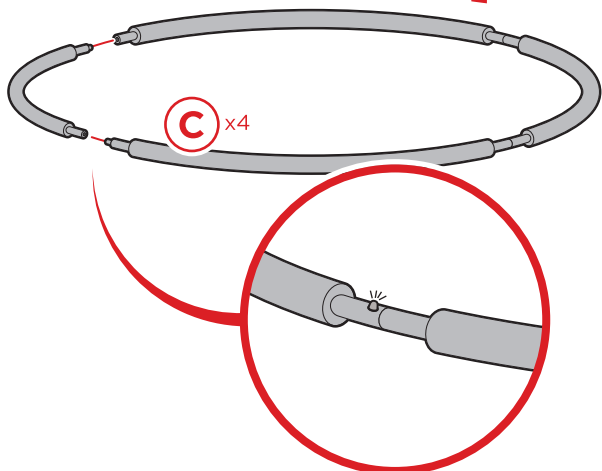

PRODUCT ASSEMBLY

3

Place the cushion D in the zippered compartment at the bottom of the tent.

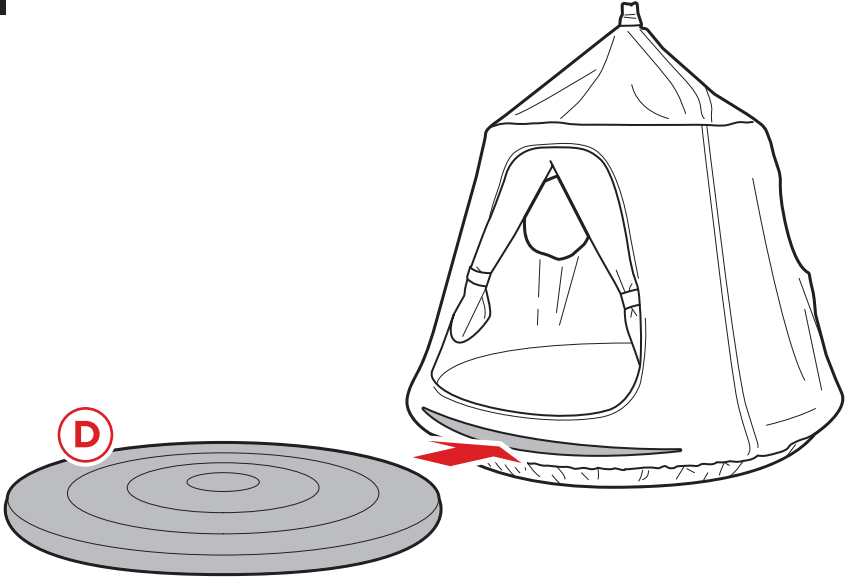

4

Install 3 AA batteries in the part E string lights. Place the battery box in the pocket, then route the string lights through the loops on the top of the tent.

Use switch to cycle between OFF, ON, and FLASHING.

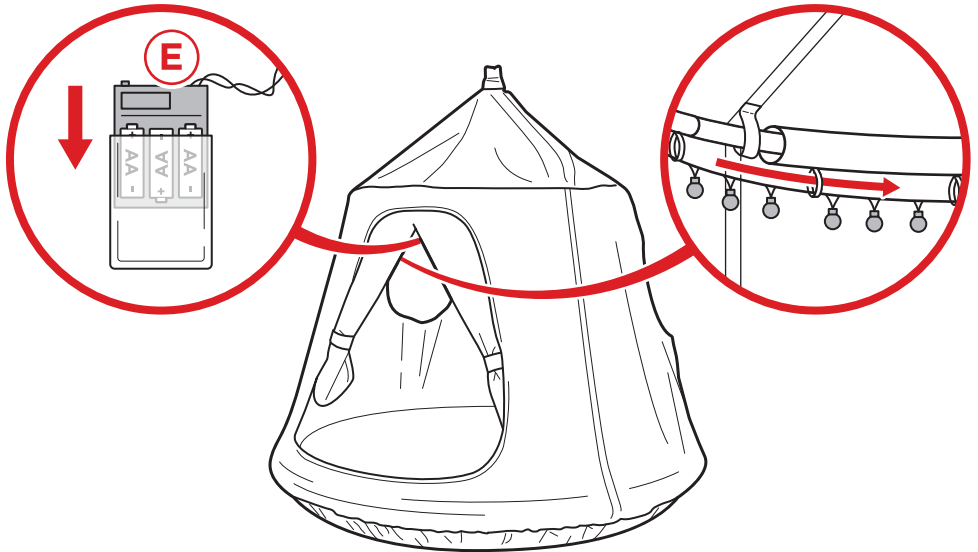

MOUNTING SWING

1

Line up the part 2 mount and use a pencil to mark the desired mounting location.

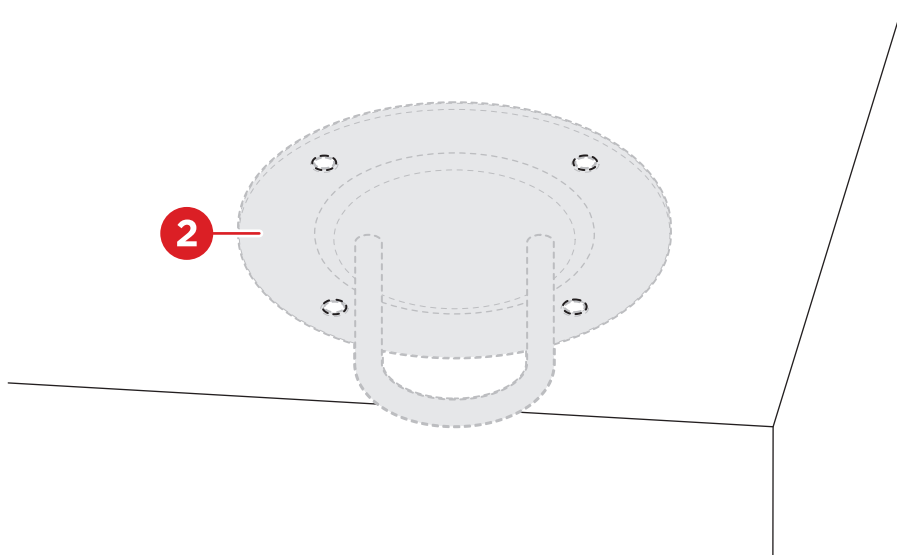

2

Drill four holes at the mounting location.

NOTE: Drill approximately a 1/4" deeper than the length of the sleeve anchor.

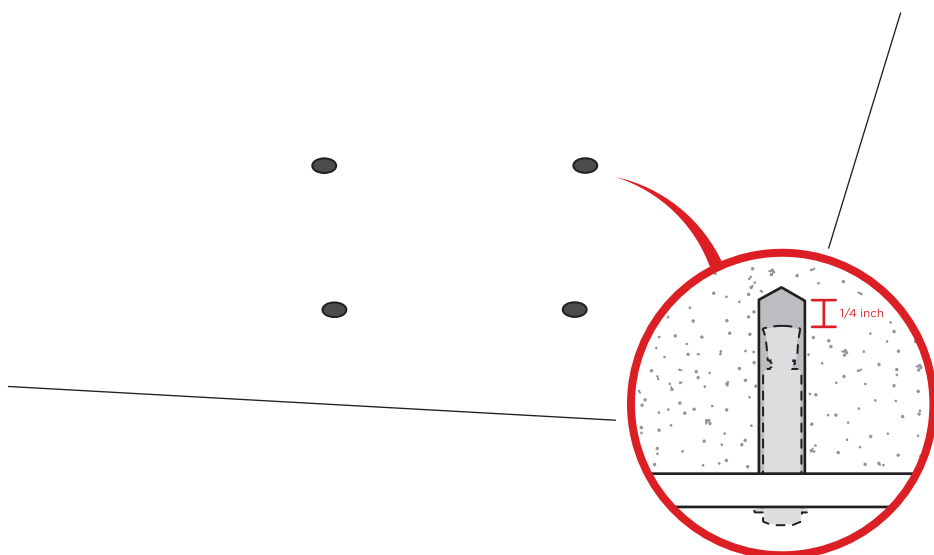

MOUNTING SWING

3

Insert four part 1 sleeve anchors into the holes. Use a hammer if necessary.
Remove the nuts/washers from the sleeve anchors.

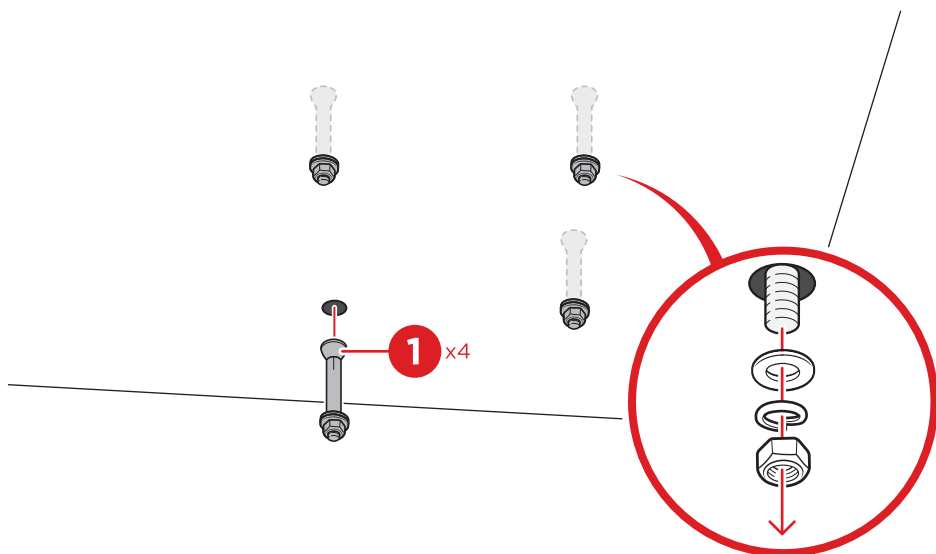

4

Place the mount, then tighten the nuts to secure the mount.

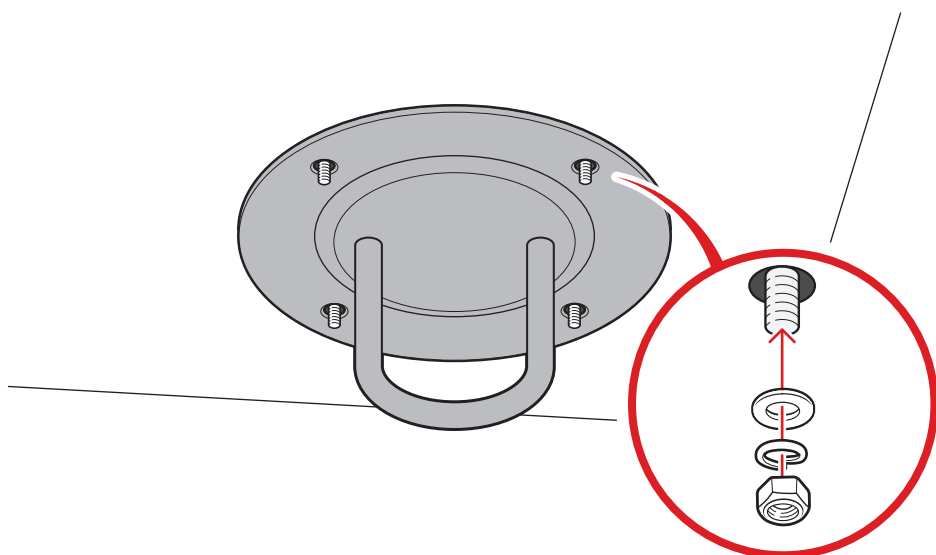

MOUNTING SWING

5

Use the part 4 carabiners and part 3 rope to hang the tent swing from the mount.

NOTE: The swing can also be installed on a stand, tree branch, beam, etc.

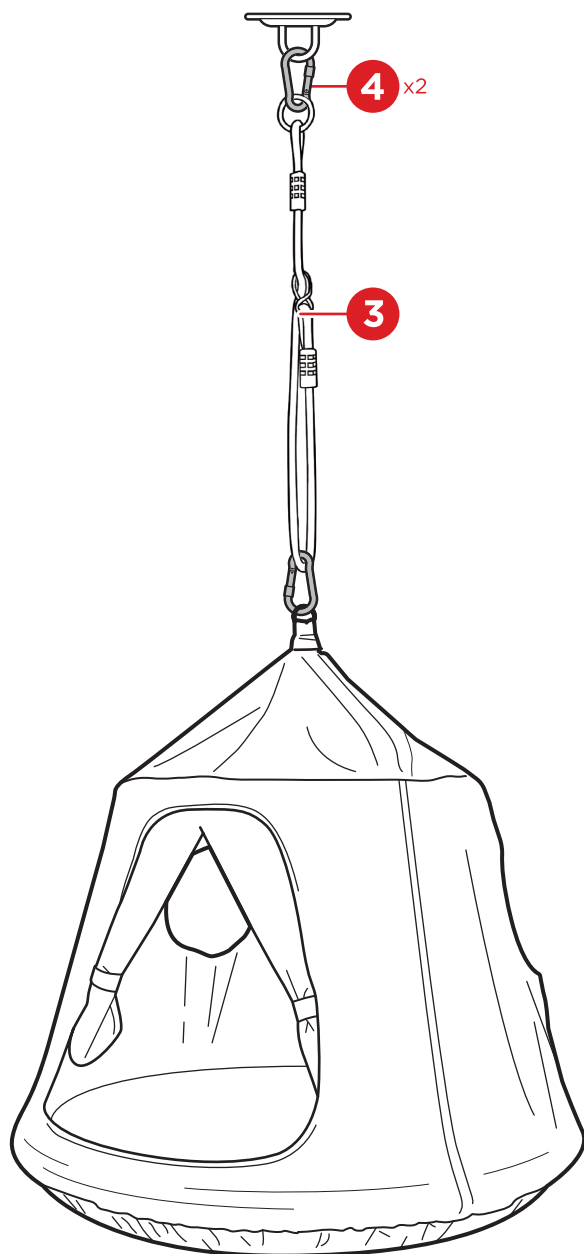

INSTALLATION TIPS

- Make sure overhead structure can support a minimum of 220 lbs. If hanging from a tree, diameter of tree limb should be 10 inches.
- Have adults test the overhead structure by pulling down or sitting in the swing.
- Do not install over concrete, asphalt, or hard ground.
- Swing should have a fall zone surrounding of the swing.
 - Fall zone should extend a minimum of 18 inches on each side and twice the swing height on the front/back.
- Place soft padding around the swing if ground is too hard.
- Do not use in a place with excessive sunlight. In warm weather, make sure that the tent swing surface is not too hot.
- Swing height should be 12 to 18 inches above the ground.
- Swing must have at least 6.5 feet of overhead and side clearance from any structure or obstruction such as a fence, garage, house, branches, wires, etc.
- Install in an area clear of wires, walls, structures, furniture, etc.

CARE AND MAINTENANCE

- Reconfirm that all nuts, bolts, and screws are tight and secure.
- Grease hardware and hanging points regularly.
- Check hardware and hanging points for rust which could affect their strength. Replace if necessary.
- Check seat, air cushion, and tent for excessive wear and tear.
- Check ropes for fraying, wear, or breakage. Replace if necessary.
- Do not leave the tent swing outdoors for an extended period of time.
- In winter season, it is recommended that the tent swing is stored indoors.
- To clean, wipe down with a damp cloth.
- Store in a dry place away from direct sunlight.
- Cover or store in a bag if unused for an extended period of time.

WARNING

Manufacturer and seller expressly disclaim any and all liability for personal injury, property damage or loss, whether direct, indirect, or incidental, resulting from the incorrect attachment, improper use, inadequate maintenance, or neglect of this product.