

COFFEE TABLE

Assembly Instructions - Please keep for future reference

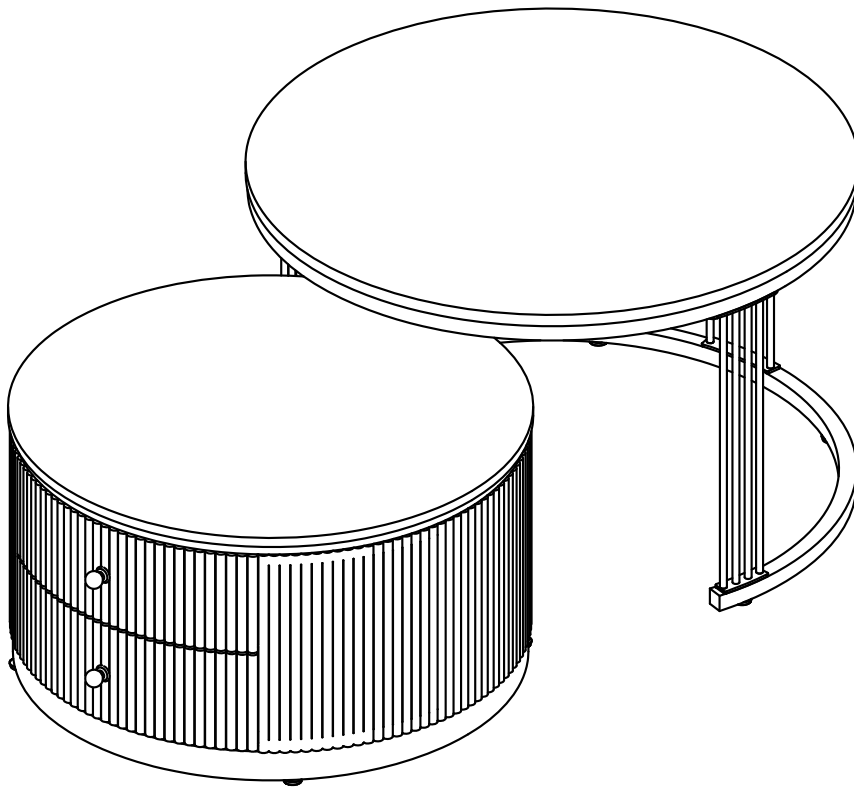

Dimensions

Width-27.56inch
Depth-27.56inch
Height-17.32 inch

Dimensions

Width-23.62inch
Depth-23.62inch
Height-12.99 inch

Important – Please read these instructions fully before starting assembly



Safety and Care Advice

Important – Please read these instructions fully before starting assembly

- Check you have all the components and tools listed on the following pages.
- Remove all fittings from the plastic bags and separate them into their groups.
- Keep children and animals away from the work area, small parts could choke if swallowed.
- Make sure you have enough space to layout the parts before starting.

- During assembly do not stand or put weight on the product, this could cause damage.
- Assemble the item as close to its final position (in the same room) as possible.
- Assemble on a soft level surface to avoid damaging the unit or your floor.
- Parts of the assembly will be easier with 2 people.



power drill is set on a low torque setting.

- To reduce the likelihood of damaging your product please ensure that your

Care and maintenance

- Only clean using a damp cloth and mild detergent, do not use bleach or abrasive cleaners.
- From time to time check that there are no loose screws on this unit.
- This product should not be discarded with household waste. Take to your local authority waste disposal centre.

Handy Hints

- Assemble all parts and bolts loosely during assembly, only once the product is complete should you fully tighten the bolts
- Regularly check and ensure That all bolts and fittings are tightened properly.

WARNING
In order to help prevent overturning – please follow these instructions







To help prevent product toppling over please follow the below steps:-

- Use the anti tip stap or wall fixing method provided (if applicable)
- Do not allow children to climb or hang on the furniture
- Do not open more than one drawer at a time
- Do not place heavy items in the top drawers
- Do not place heavy items on top of the furniture, unless the furniture has been designed for this purpose

Components - Fittings

Please check you have all the panels listed below



Note: The quantities below are the correct amount to complete the assembly. In some cases more fittings may be supplied than are required.

 M4 A x1PC	 M6*12mm B x6PCS	 M6*30mm C x6PCS
 M6*40mm D x4PCS	 E x2PCS	 M4*23mm F x2PCS

Tools required

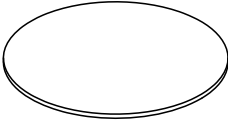
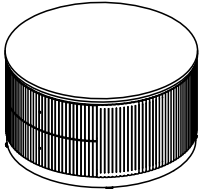
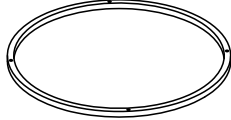
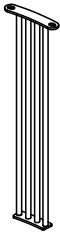

Hexagon wrench

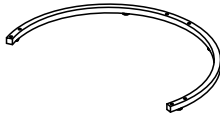
 1 x1PC	 2 x1PC	 3 x1PC
 4 x2PCS	 5 x1PC	 6 x1PC

Assembly Instructions

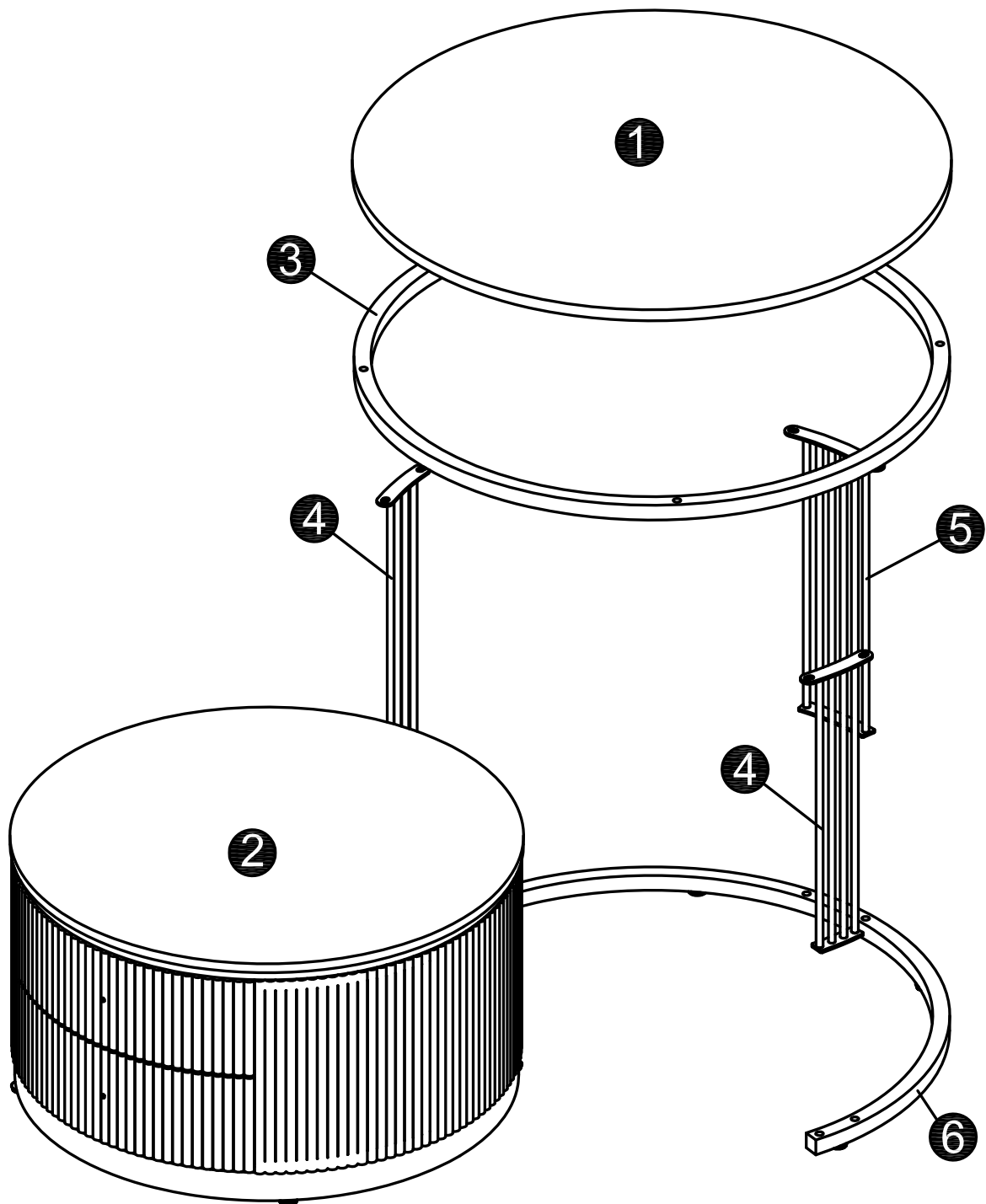

Assembly Instructions

Step 1

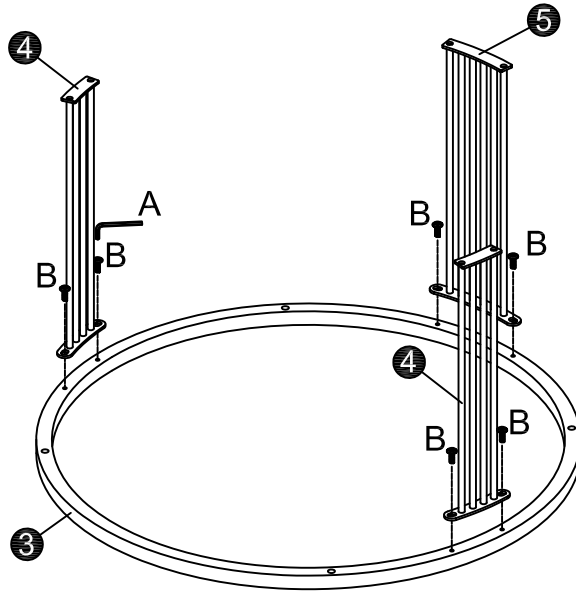

- | | | |
|---|---|------|
| A | └ | 1PC |
| B | ⚙ | 6PCS |

Step 2

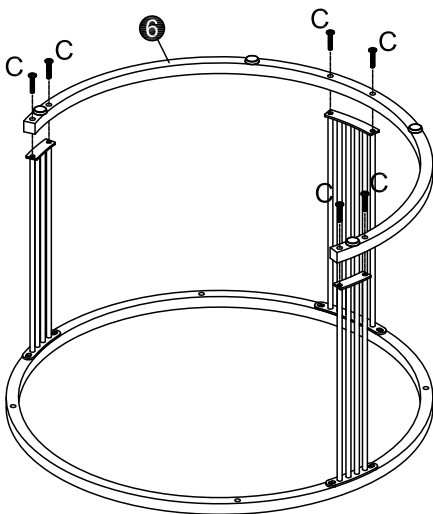

- | | | |
|---|---|------|
| C | ⚙ | 6PCS |
|---|---|------|

Step 3

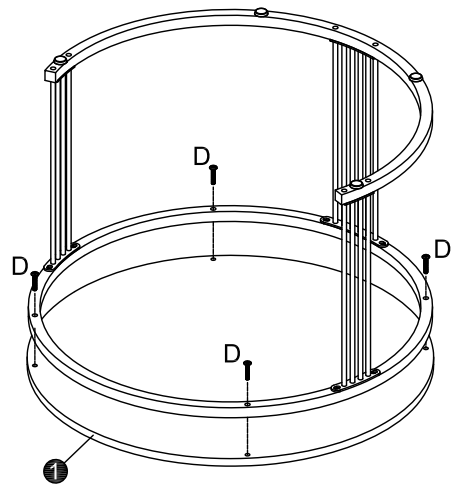

- | | | |
|---|---|------|
| D | ⚙ | 4PCS |
|---|---|------|

Assembly Instructions

Step 4

1

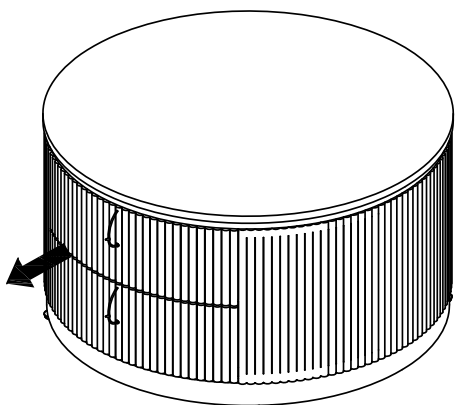

2

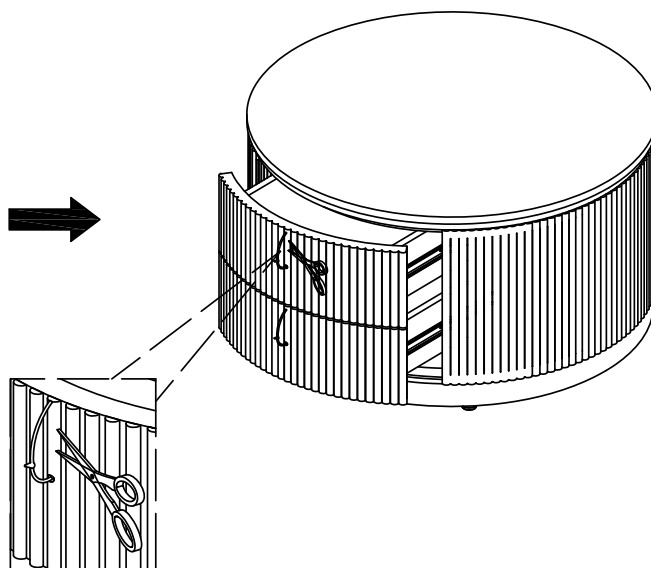

3

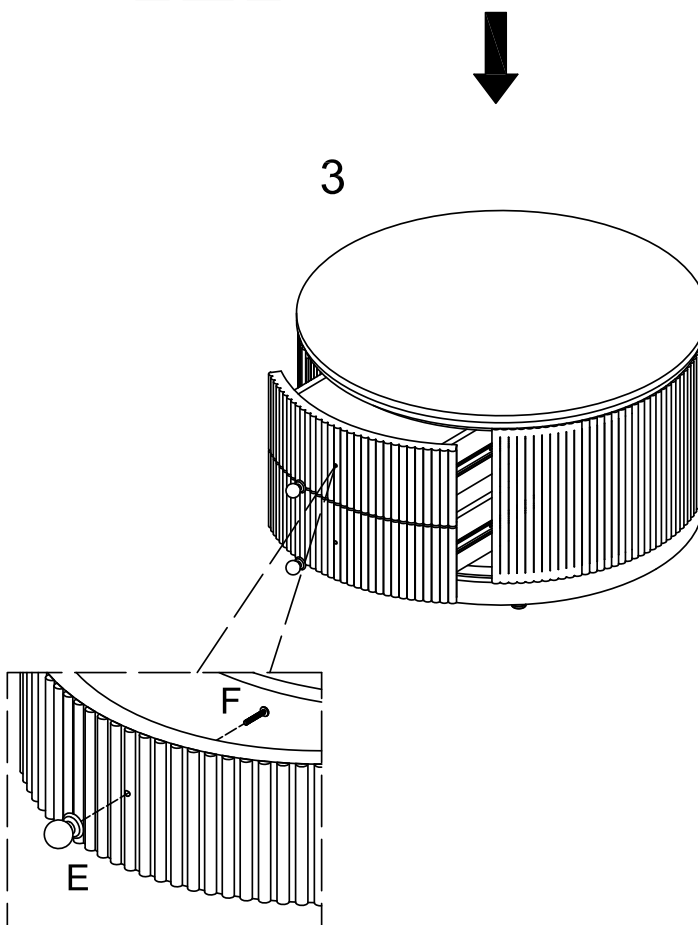

E		2PCS
F		2PCS

