

Notice de montage
 Assembling instructions
 Montageanleitung

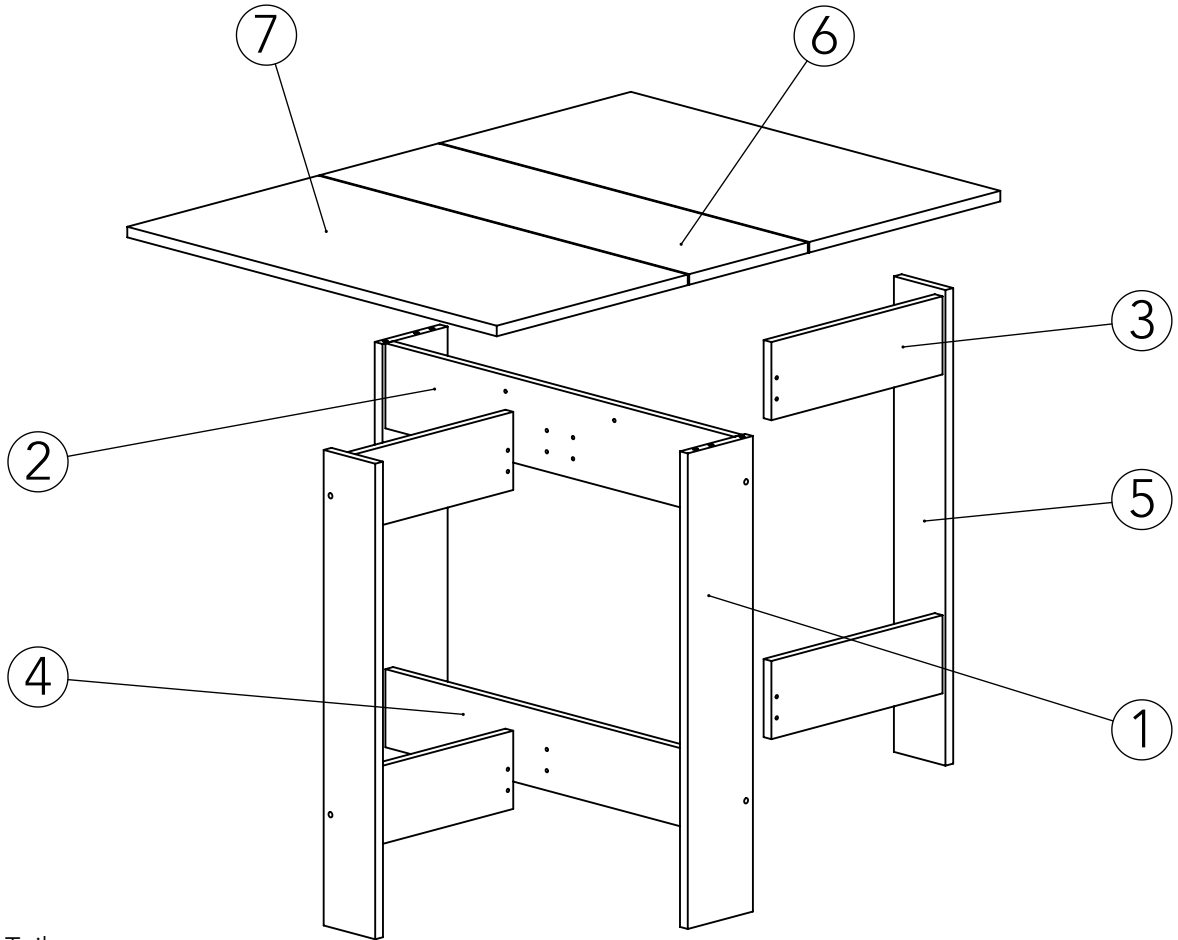

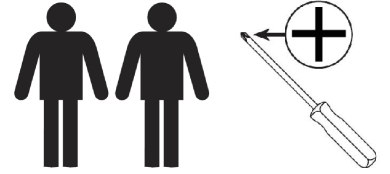





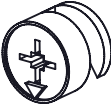

2h



N° Pièce / Part / Teile

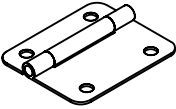

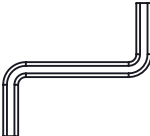
N° Pièce	Qté	Dimensions
1	2	718 x 134 x 16
2	1	128,50 x 718 x 16
3	4	118 x 352 x 16
4	1	118 x 718 x 16
5	2	718 x 106 x 16
6	1	760 x 244 x 16
7	2	760 x 393 x 16

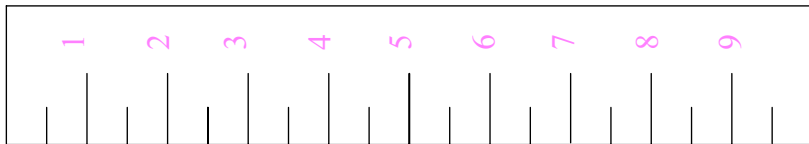
Code	Qté	Image
AA	2	
BA	2	
DA	22	
FB	44	 6.3 x 11 mm
CA	8	 6.3 x 50 mm
NE	2	
KT	10	
EDB	22	
Clef	1	



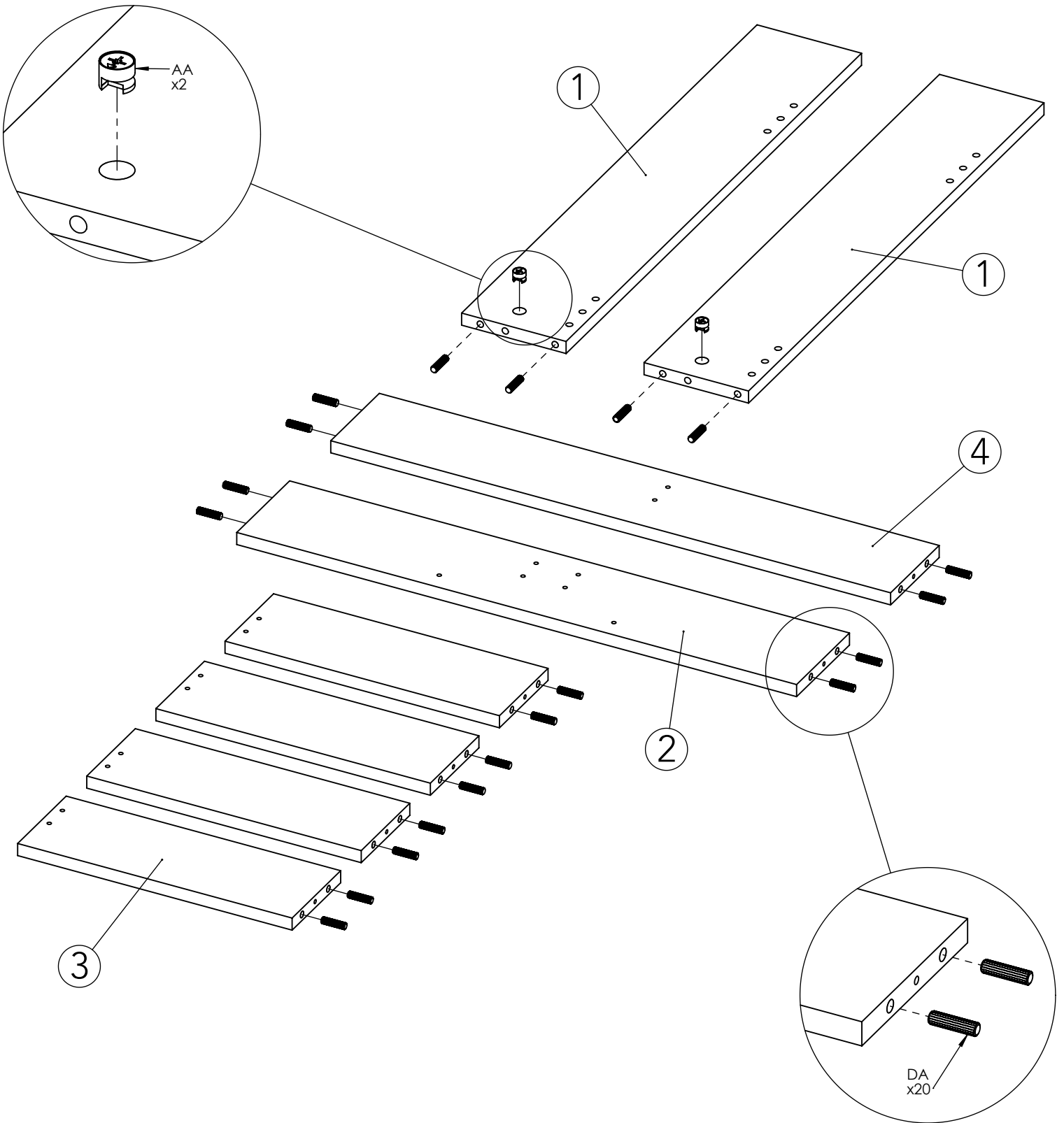

1

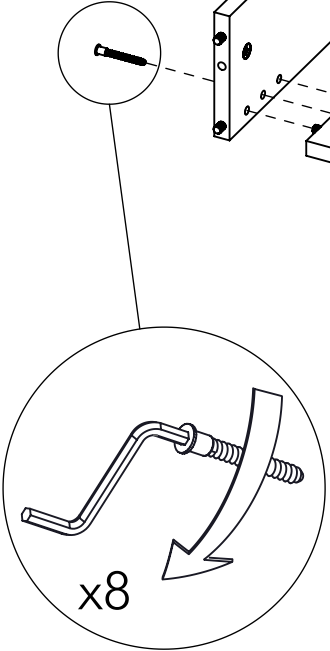
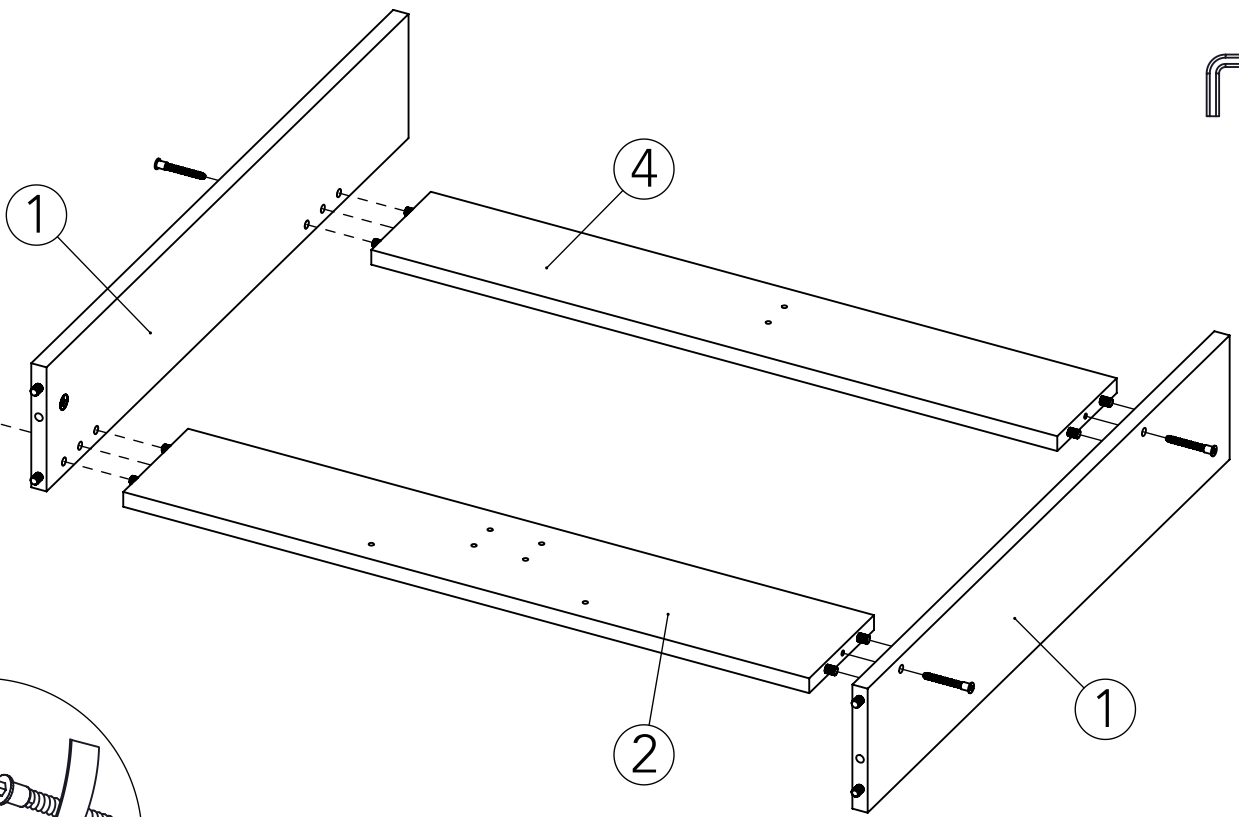
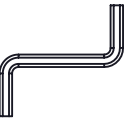

Code	Qté	Image
AA	2	
DA	20	

2



Code	Qté	Image
CA	4	 6.3 x 50 mm

3

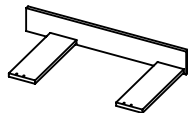
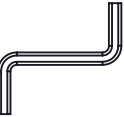
	x2	
---	----	---

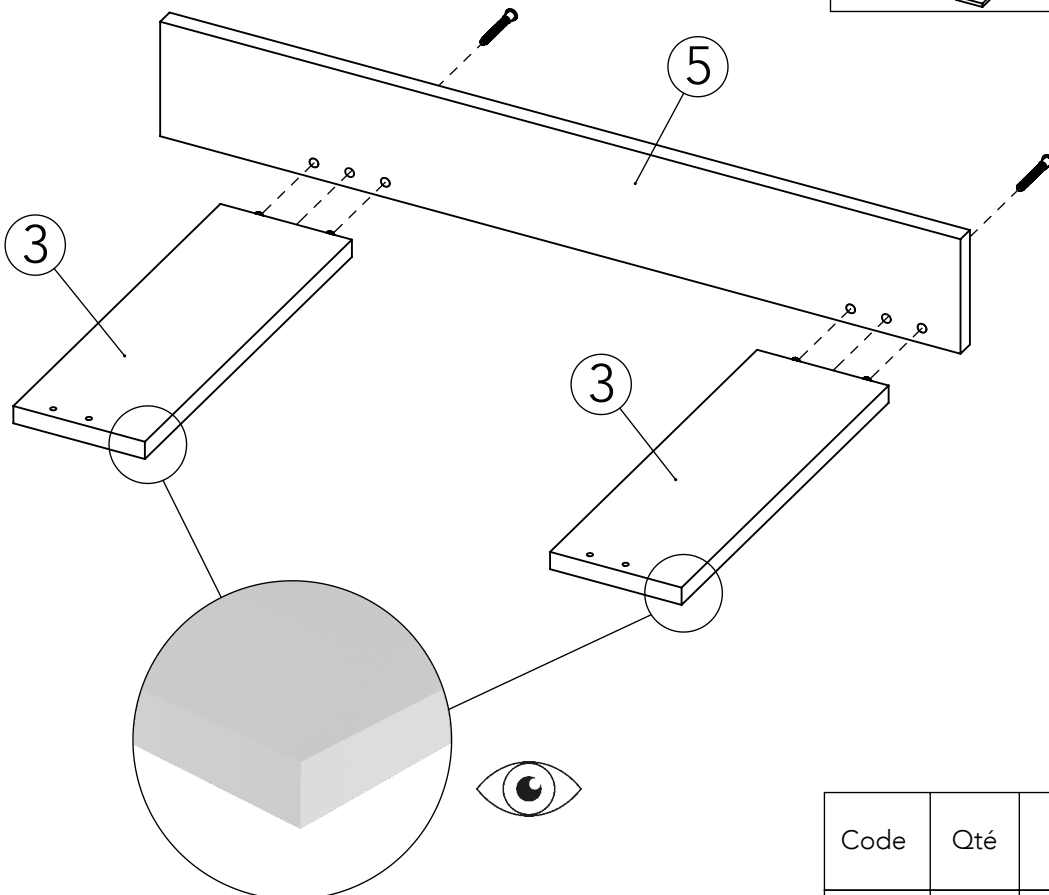

Code	Qté	Image
CA	4	 6.3 x 50 mm

4

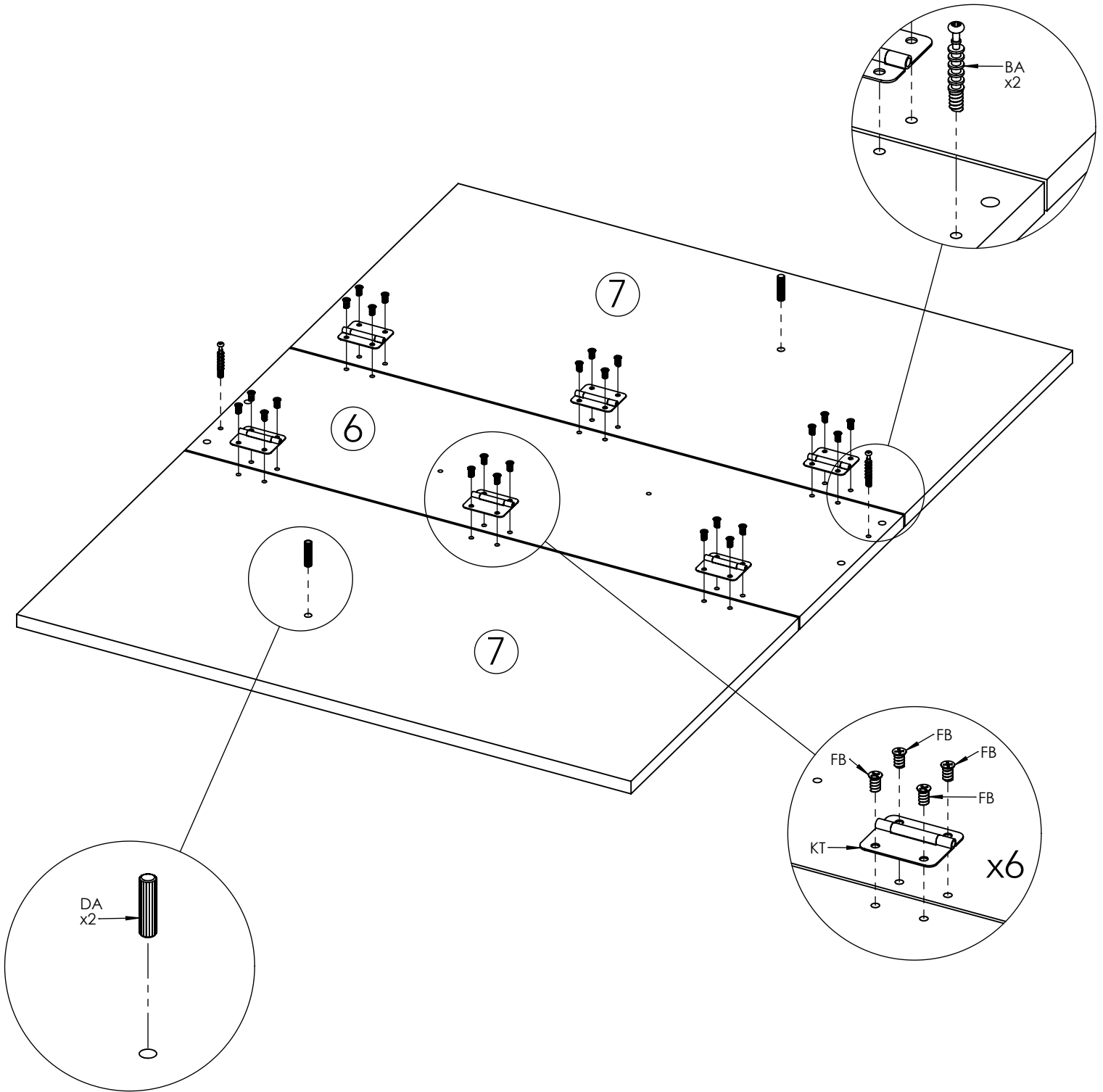
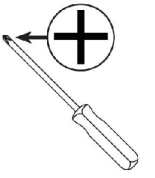

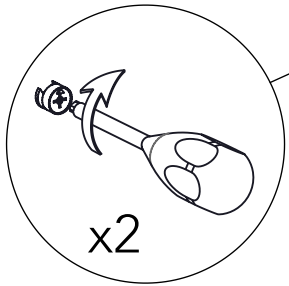
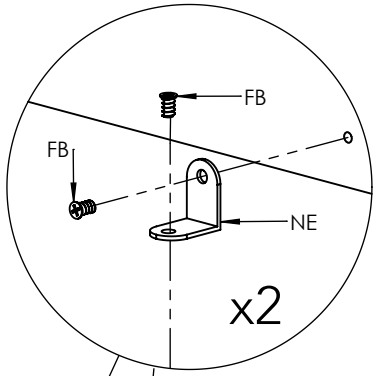
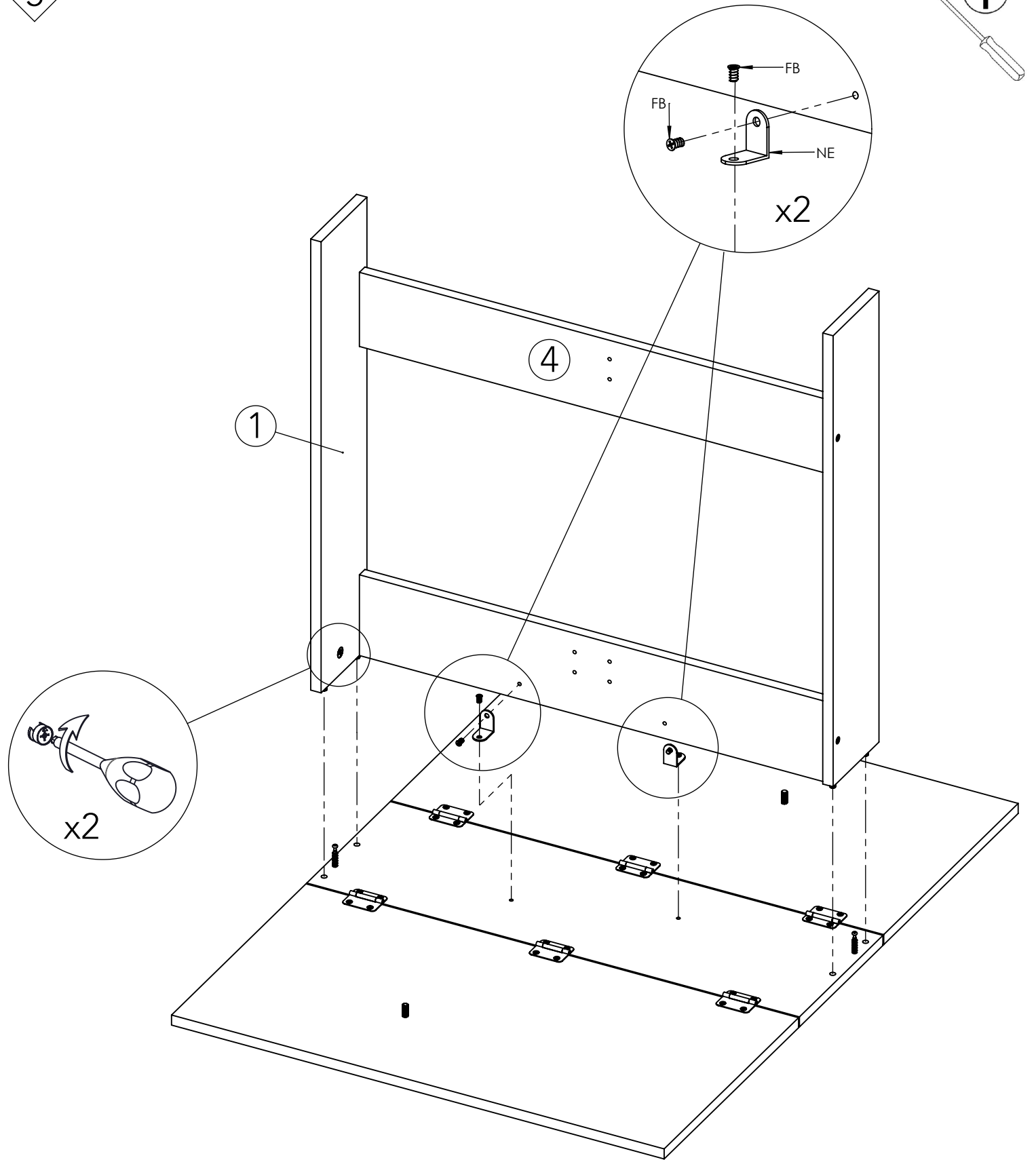
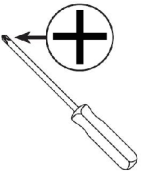

Code	Qté	Image
DA	2	
FB	24	6.3 x 11 mm
BA	2	
KT	6	

5

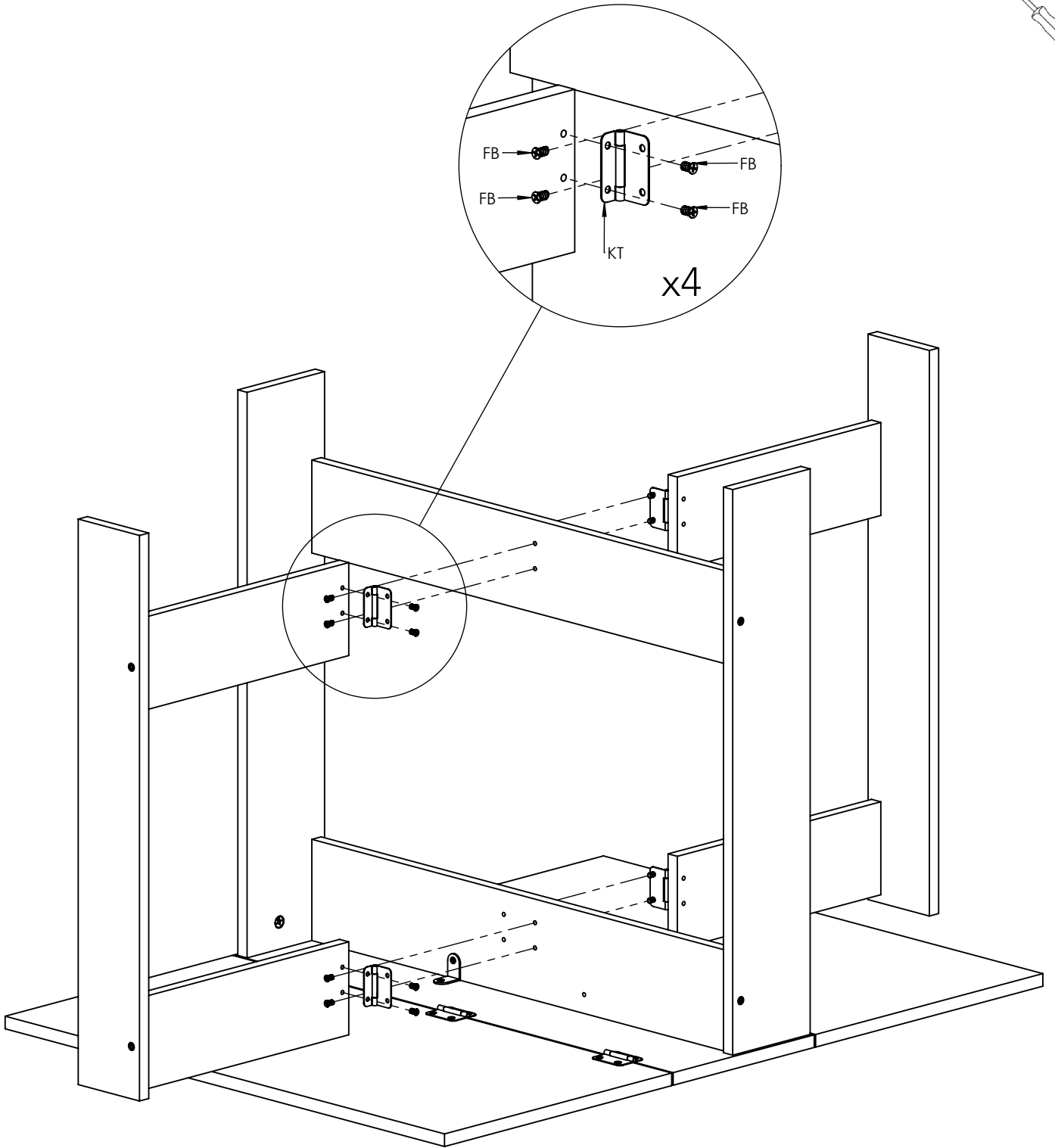
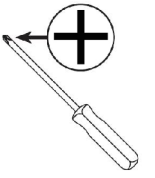

Code	Qté	Image
NE	2	
FB	4	6.3 x 11 mm



Code	Qté	Image
FB	16	 6.3 x 11 mm
KT	4	

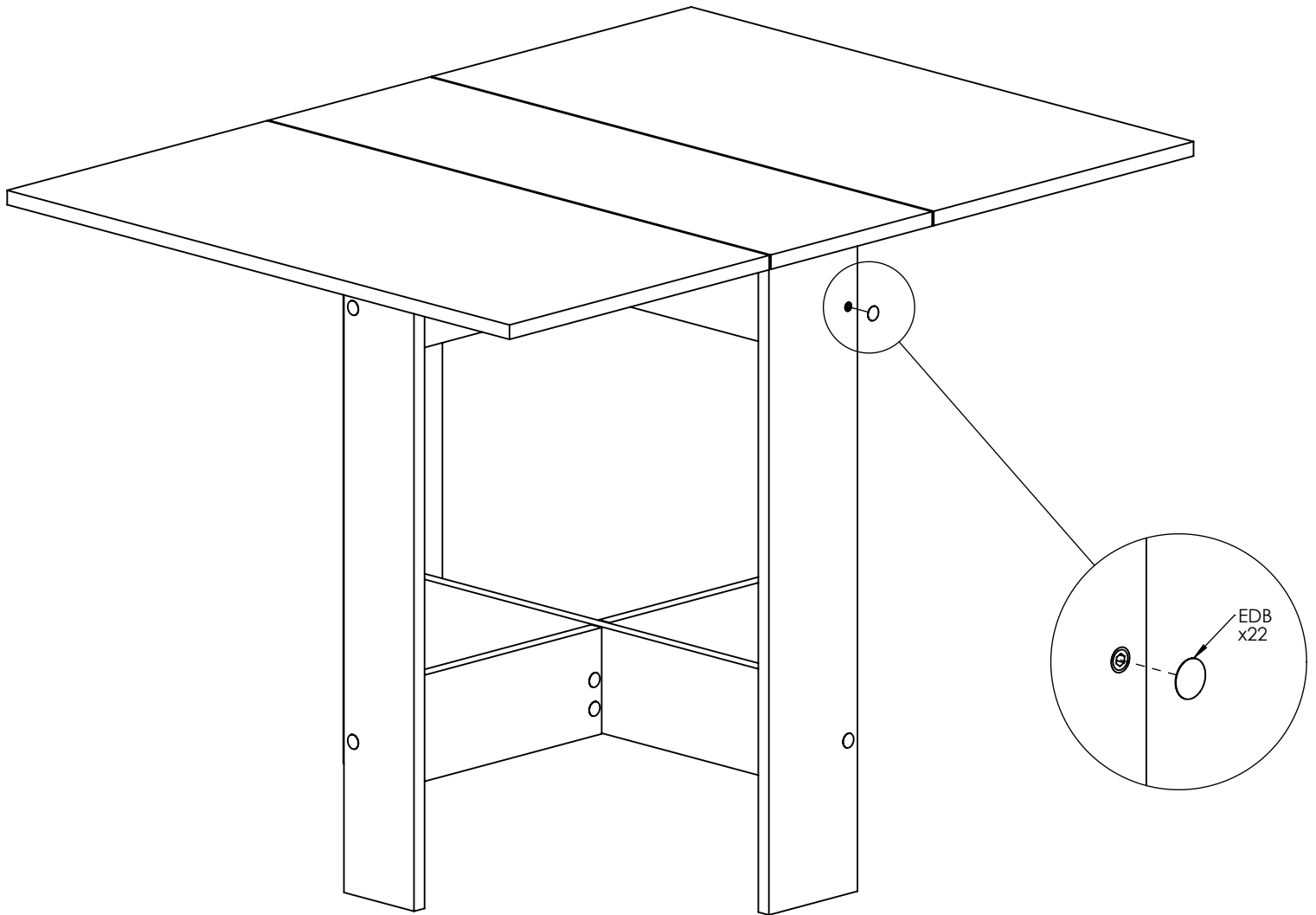

Code	Qté	Image
EDB	22	

INSTRUCTIONS D'ENTRETIEN

Laver les surfaces à l'aide d'un chiffon doux, préalablement trempé dans une solution savonneuse (max. 1%).
ATTENTION! Ne pas utiliser de produit contenant de l'alcool ou de l'abrasif.
 Essuyer à l'aide d'un chiffon doux.

CARE AND CLEANING INSTRUCTIONS

Wash the surfaces with a soft cloth damped in a mild soap solution (max 1%).
NOTE! Do not use cleaners containing alcohol or abrasives.
 Wipe the surface dry with a soft cloth.

PFLEGEHINWEIS

Zur Reinigung und Pflege verwenden sie, ein feuchter Lappen mit Seifenlauge (max 1%) zum Abwischen
WICHTIG! Keine alkoholhaltigen Mittel oder Schleifmittel verwenden.
 Die Oberfläche mit einem weichen Tuch abtrocknen.

