

ASSEMBLY INSTRUCTION FOR MIRROR INSTALLATION

HARDWARES

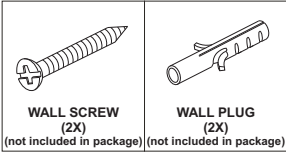

TOOLS (Not included in package)

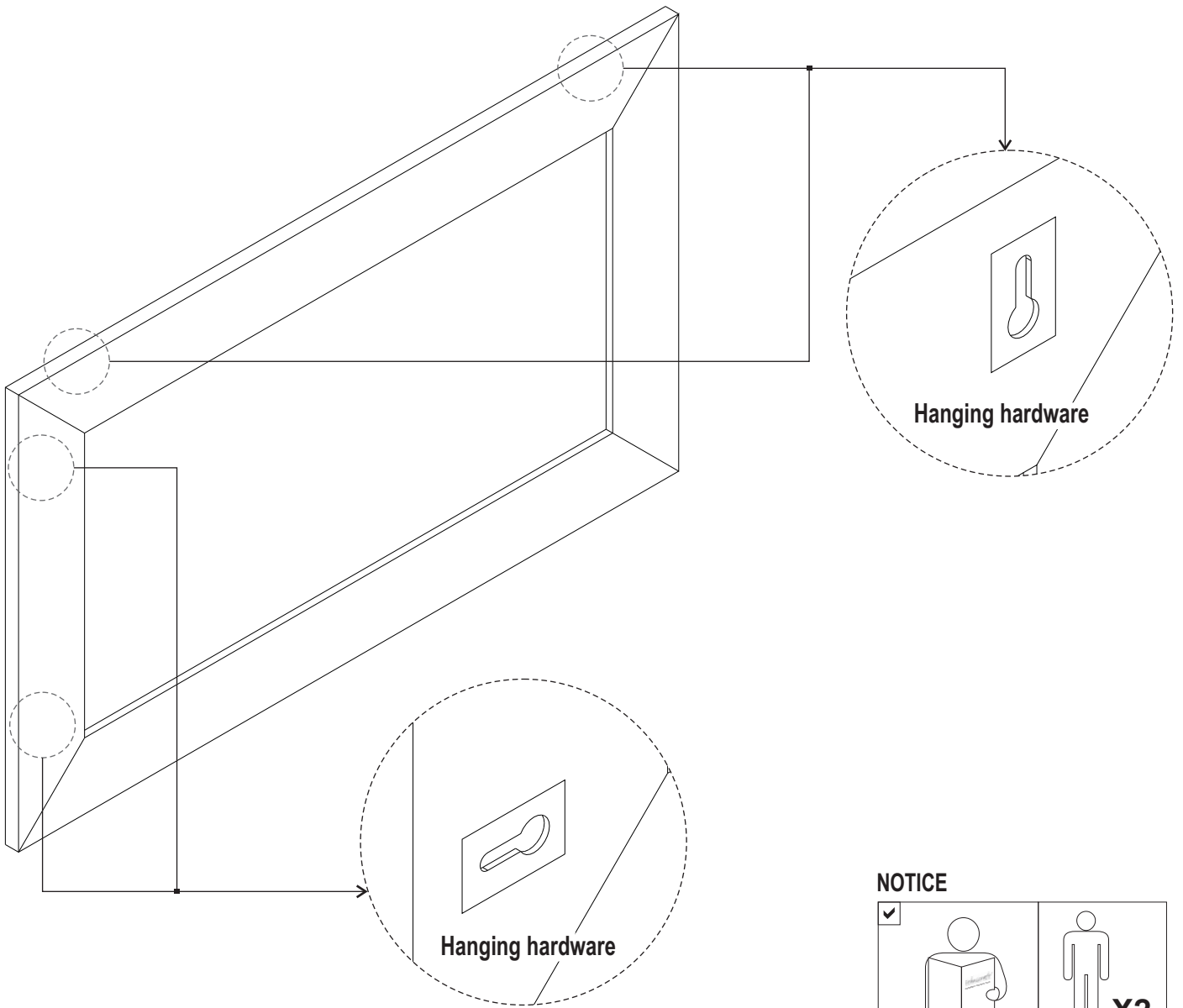
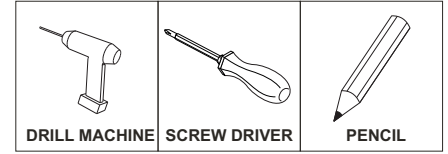

NOTICE

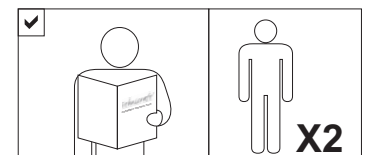

SYMBOLS



DIRECTION

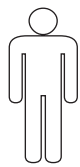

NUMBER OF PERSON NEEDED



USE HAND

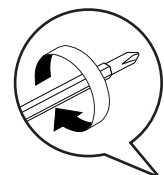

USE L KEY TO TIGHTEN

ASSEMBLY INSTRUCTION FOR MIRROR INSTALLATION

A. INSTALLING WALL PLUG

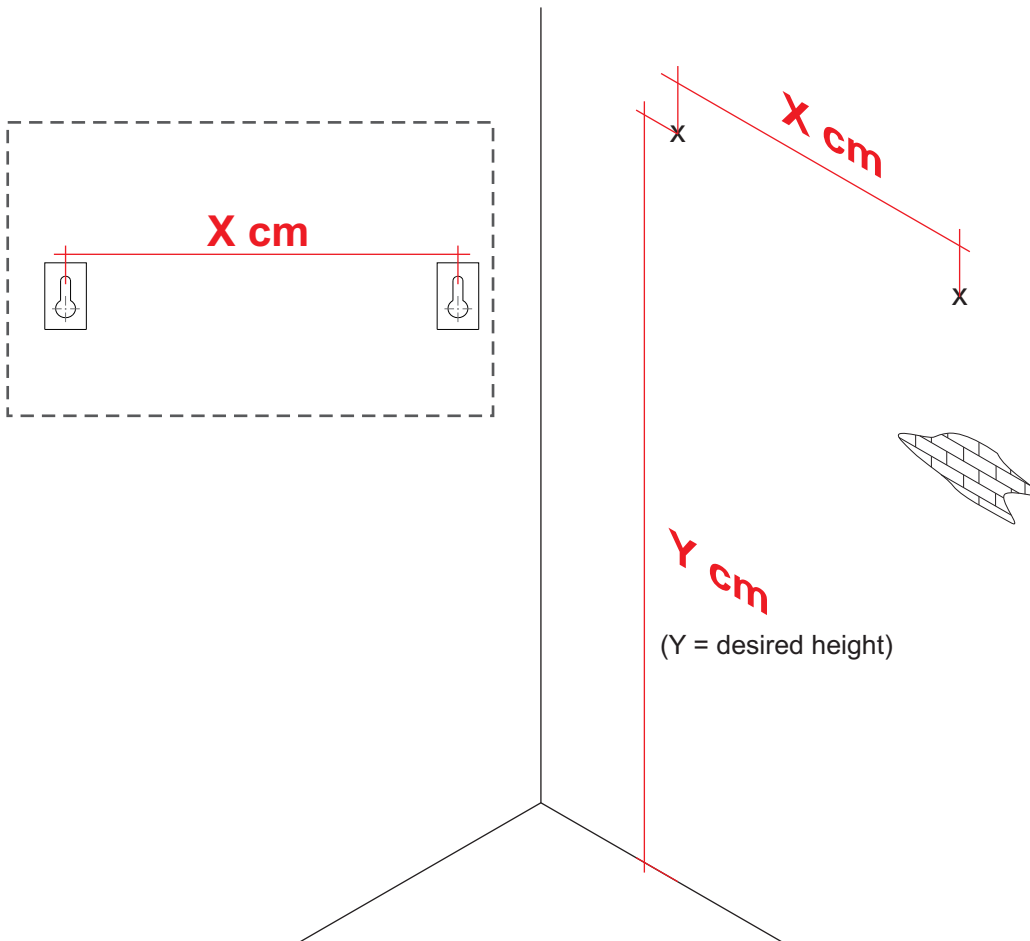

1

Ø 8 mm

2

3

i X = DRILLING MARK

B. INSTALLING MIRROR TO THE WALL

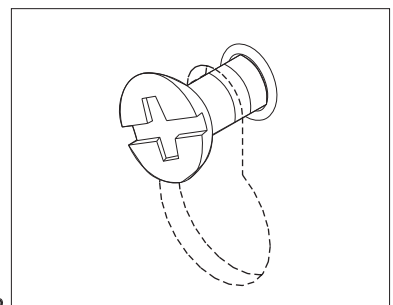
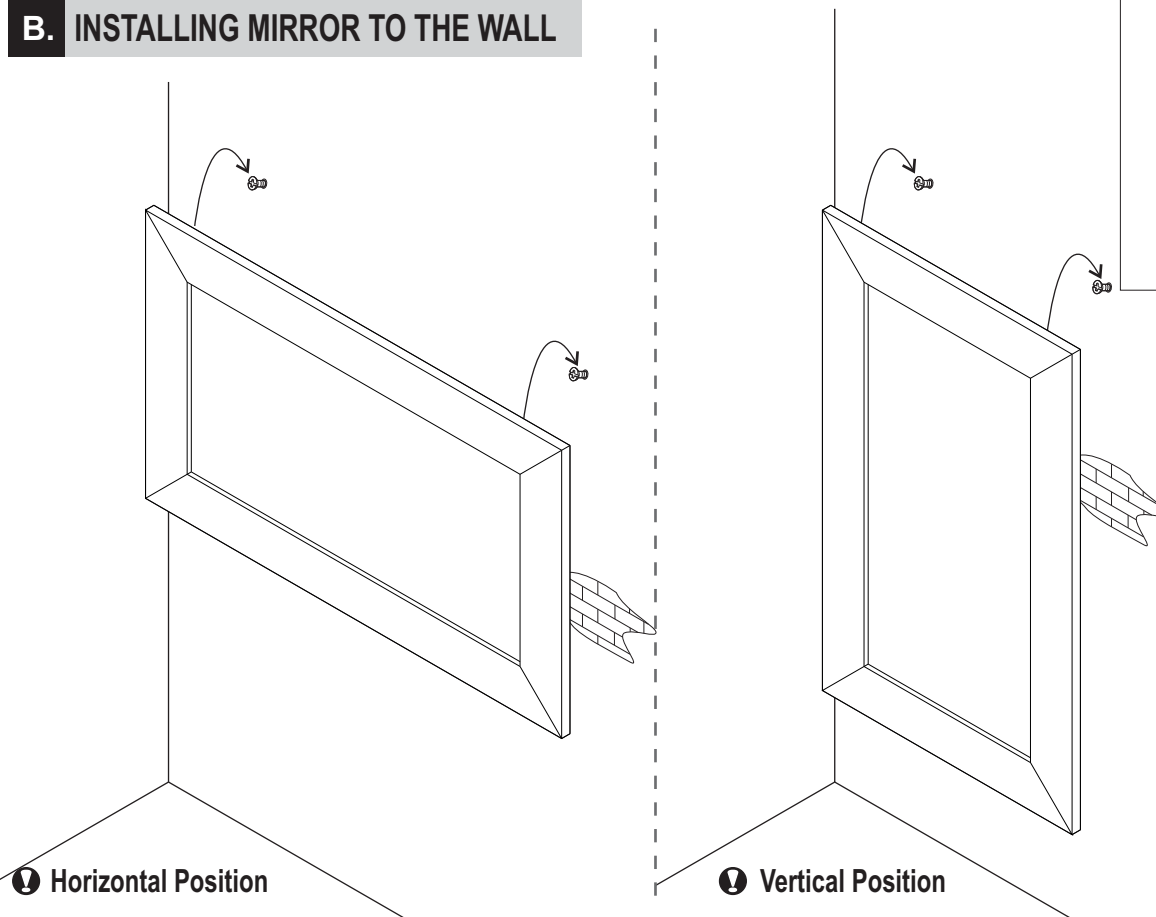



⬇ Horizontal Position

⬇ Vertical Position

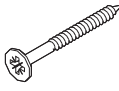

Ethnicraft

ASSEMBLY INSTRUCTION FOR ANTI-TIPPING INSTALLATION

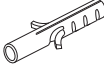
HARDWARE ENCLOSED

A  (1X) BELT ANTI-TIPPING	B  (1X) WALL SCREW M5x50mm	C  (1X) SCREW M5x30mm	D  (1X) WASHER Ø6	E  (1X) WALL PLUG M8x40mm
---	--	---	---	---

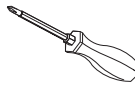
TOOLS

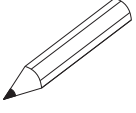
 SCREWDRIVER (not included in package)	 DRILLING MACHINE (not included in package)
 PENCIL (not included in package)	



AS WALL MATERIALS VARY,
THE SCREW INCLUDED ARE FOR BRICK WALL.
FOR ADVICE ON SUITABLE SCREW SYSTEMS,
CONTACT YOUR LOCAL SPECIALISED DEALER.

INSTALLING ANTI-TIPPING SYSTEM

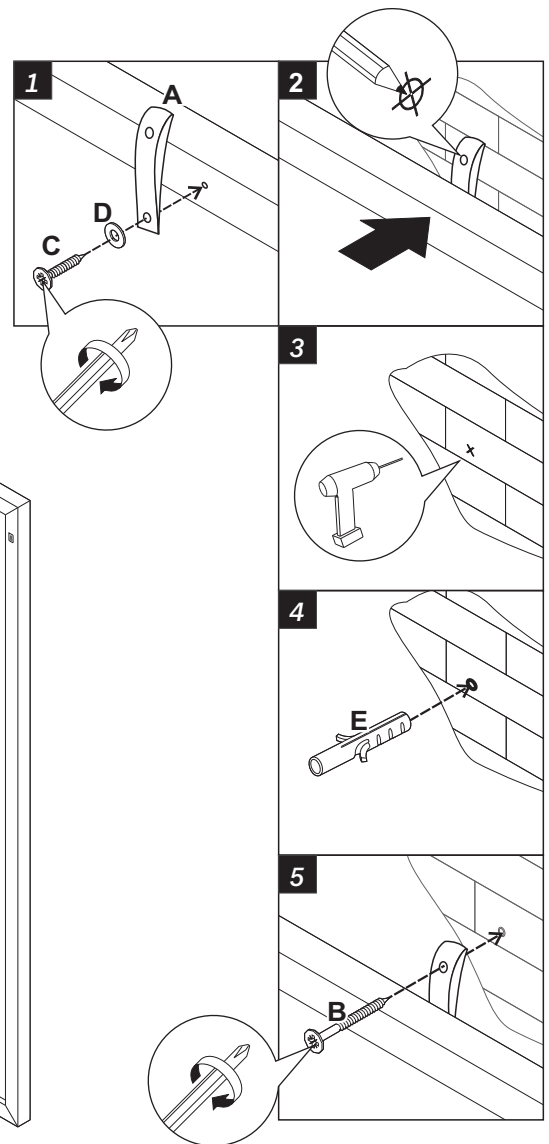
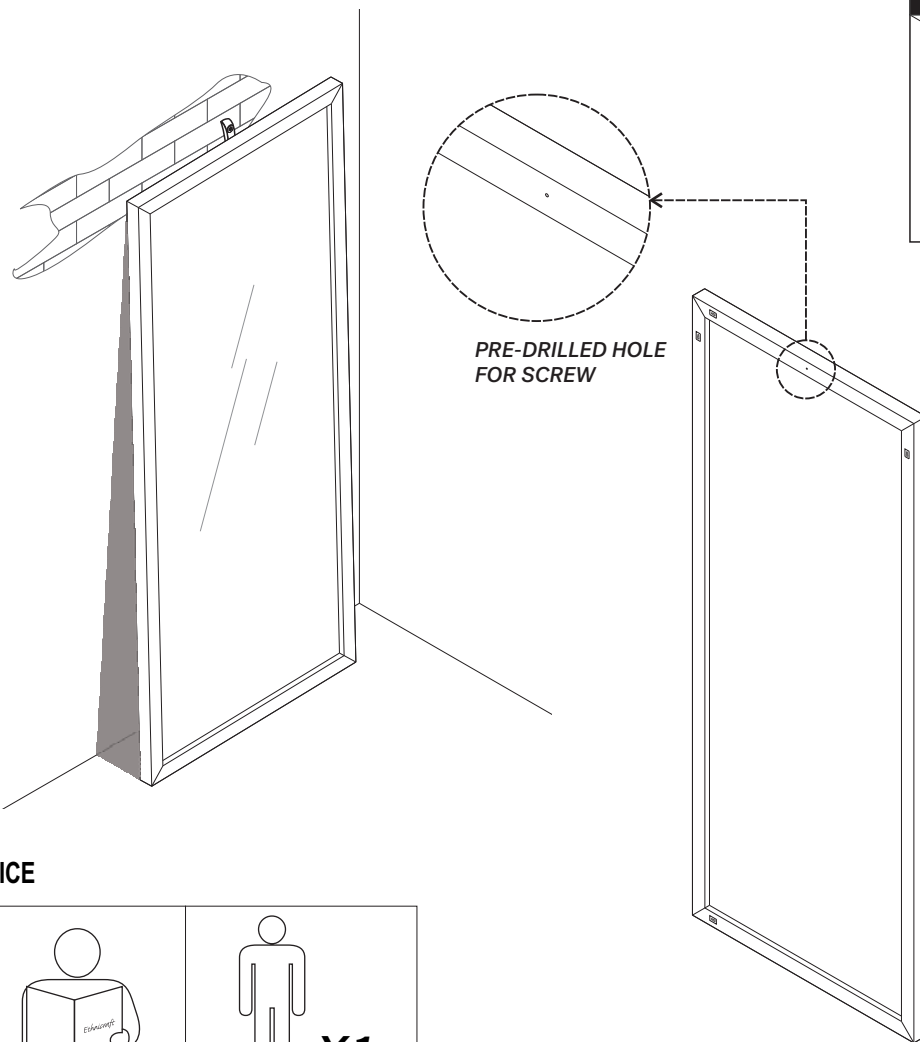

NOTICE

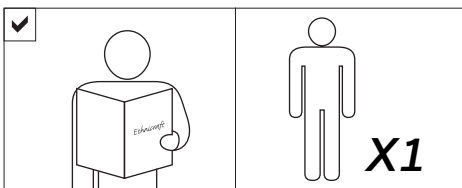

INSTRUCTION

1. Install anti-tipping belt (A), washer (D) with M5x30mm screw (C) into the pre-drilled hole on the top back frame of the mirror.
2. Using a 1/4" diameter drill bit, drill the wall at the same level as the anti-tipping belt (A) on the mirror. Install the wall plug (E) into the hole.
3. Connect the anti-tipping belt (A) with wall screw (B) into the wall plug (E).