

PRODUCT GUIDE AND INSTALLATION MANUAL

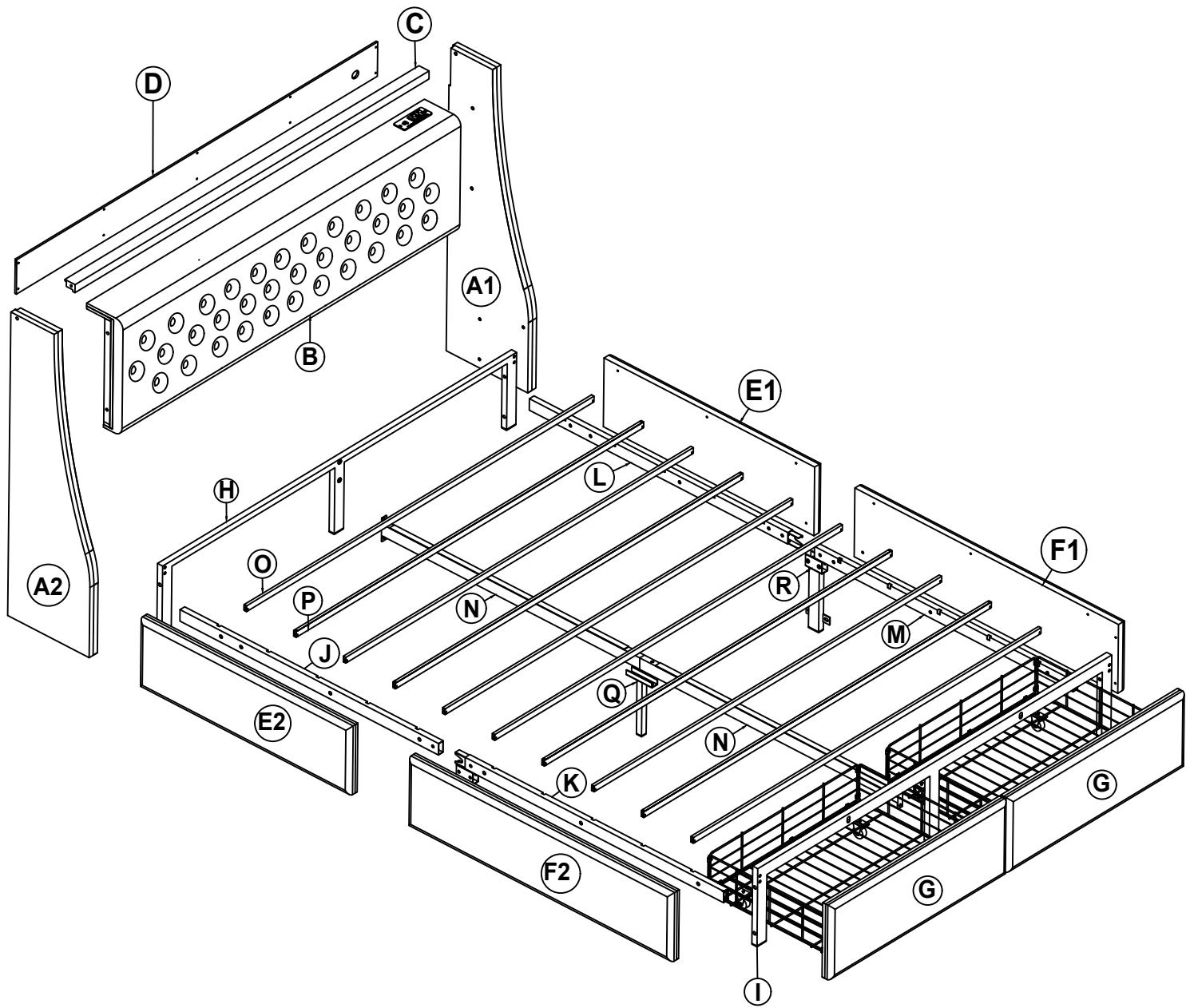

Parts List:

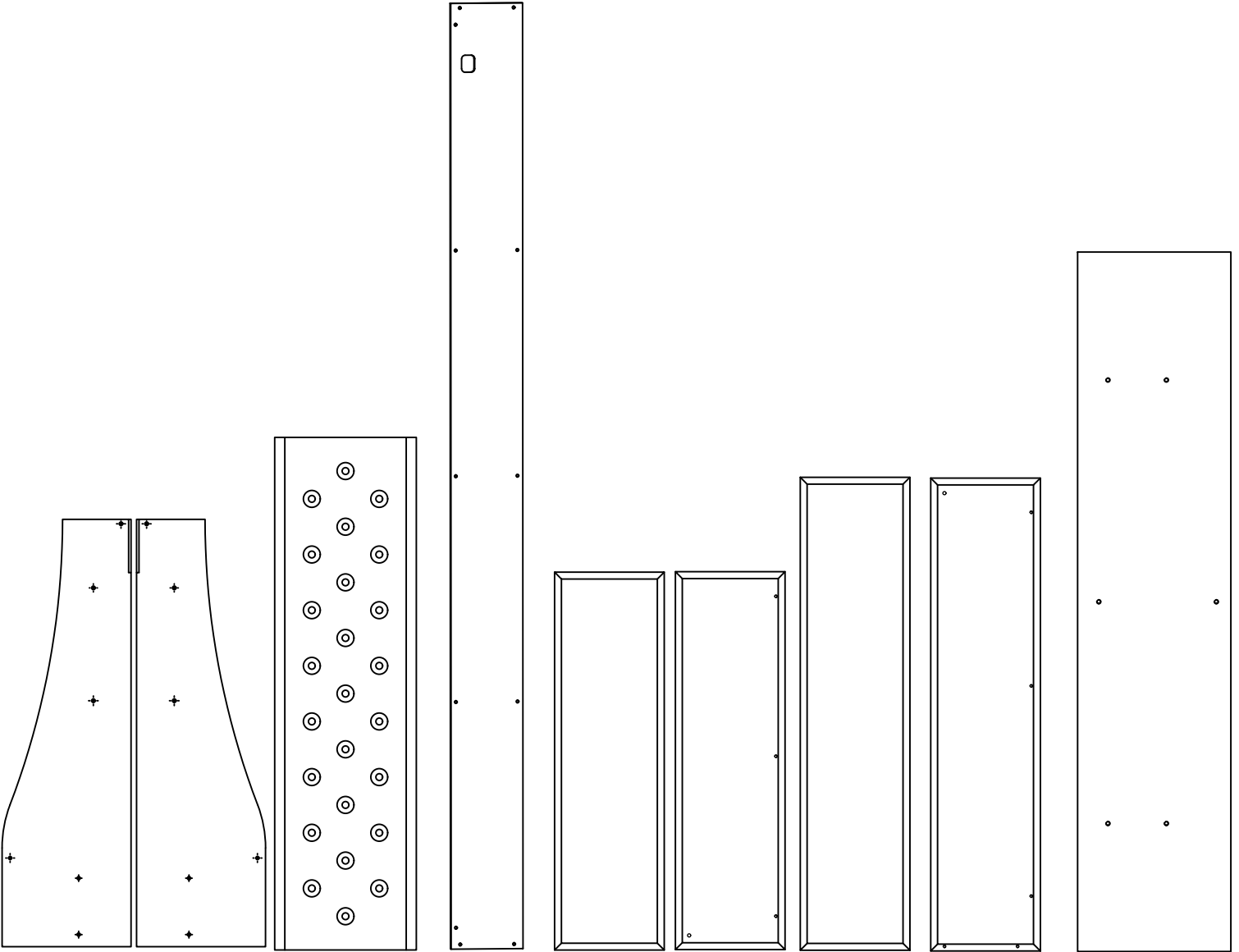

A2

1pcs

A1

1pcs

B

1pcs

D

1pcs

E1

1pcs

E2

1pcs

F1

1pcs

F2

1pcs

G

2pcs

Parts List:

Double-sided tape

EVA

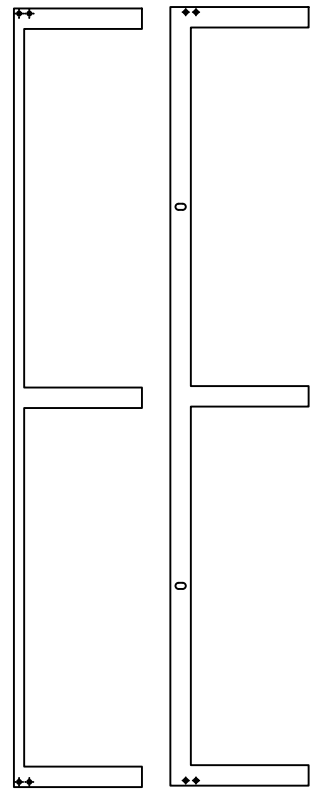

(H)
1pcs

(I)
1pcs



(J)
1pcs

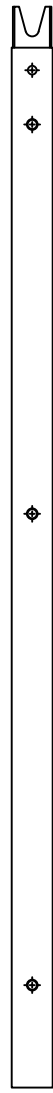

(K)
1pcs



(L)
1pcs

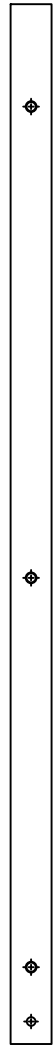

(M)
1pcs

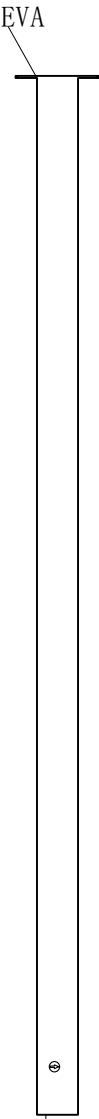

(N)
2pcs



(O)
6pcs

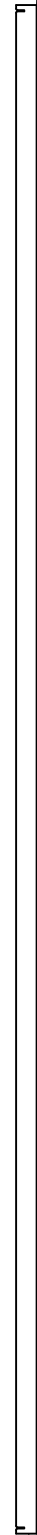

(P)
4pcs



(C)
1pcs

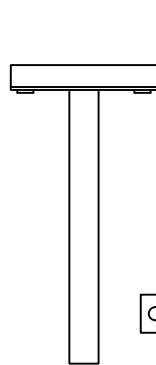

(Q)
1pcs

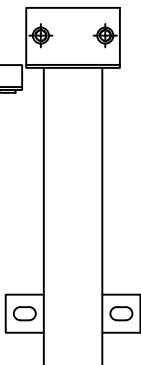

(R)
2pcs

Parts List:

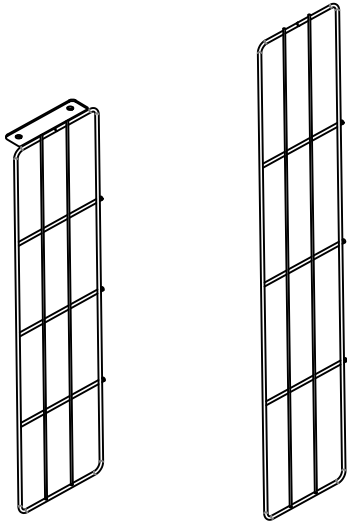

Z2
4pcs

Z3
2pcs

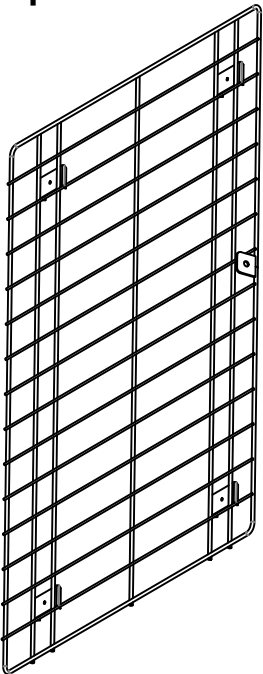

Z4
2pcs

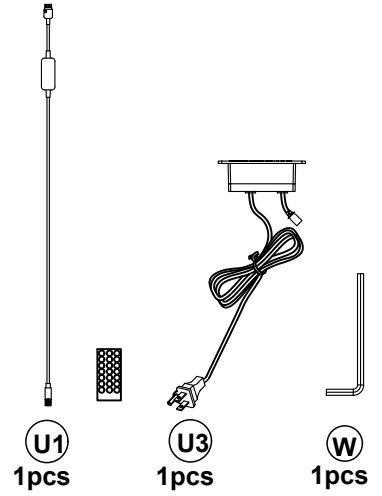

U1
1pcs

U3
1pcs

W
1pcs

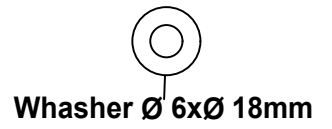

Washer Ø 6xØ 18mm



X
2pcs



M6x40mm



M6x45mm



M6x55mm



T3
4pcs



T4
4pcs



T5
8pcs



M4x15mm



M6x15mm



M6x30mm



V
16pcs



T1
14pcs



T2
12pcs



M8x35mm



M8x55mm



M8x15mm



Y1
12pcs



Y2
2pcs



Y3
4pcs

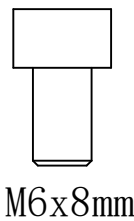

M6x8mm



Z8
2pcs



Z5
8pcs

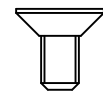

M4x6mm



Z6
8pcs

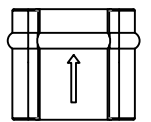

Q1
22pcs

1.1

Step 1

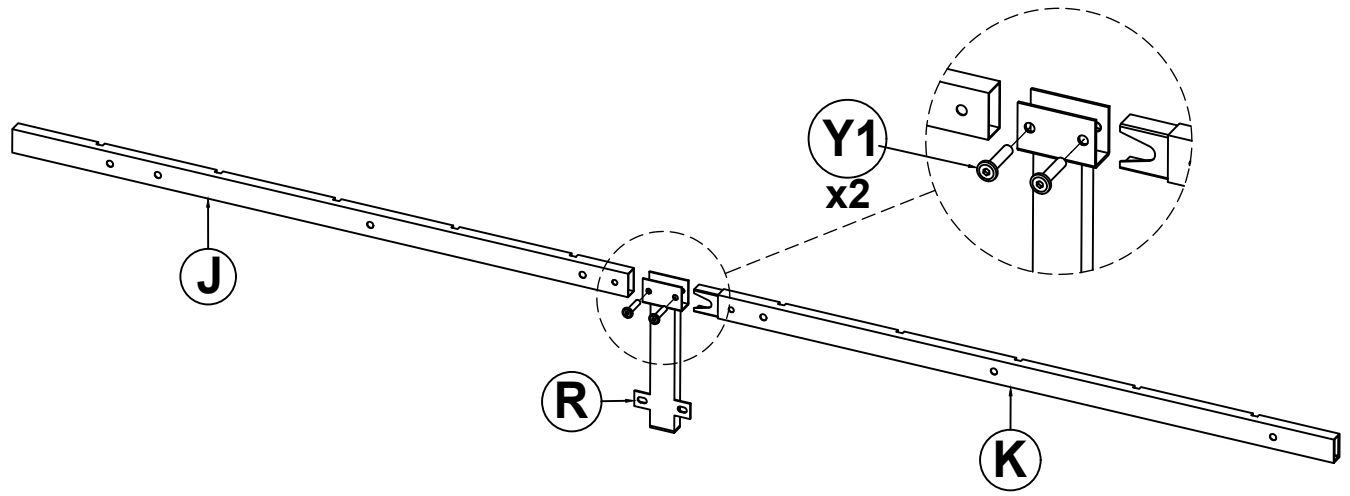

1.2

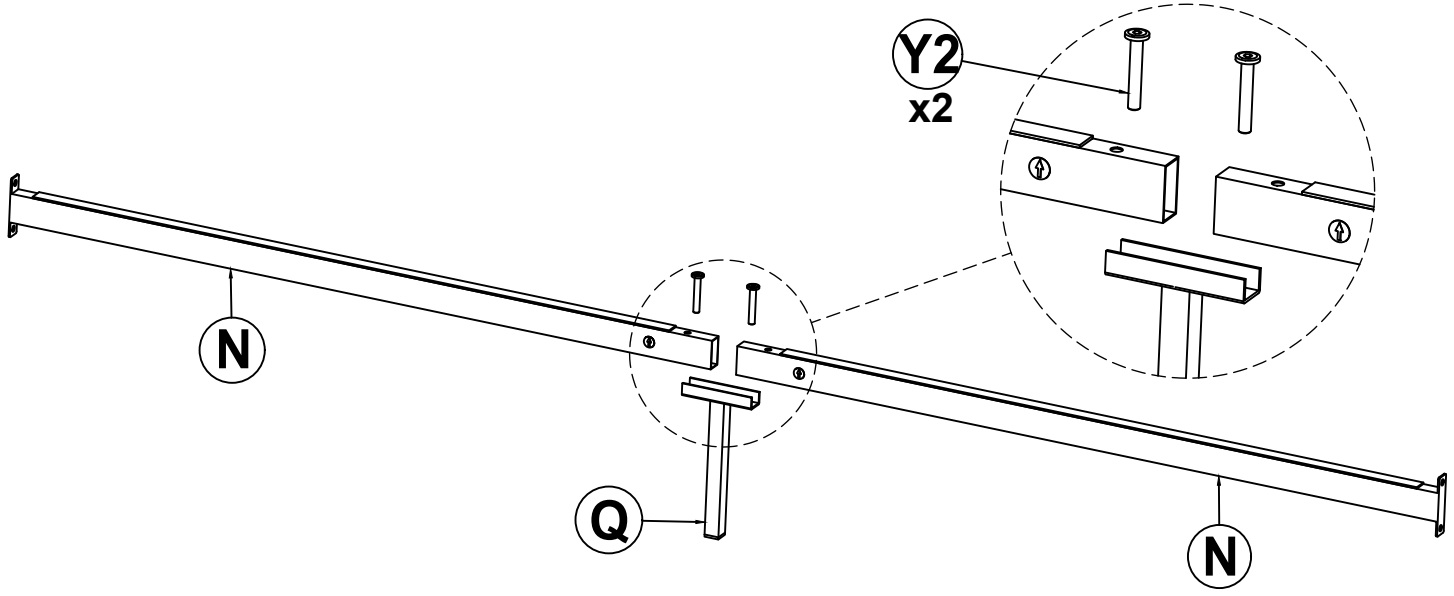

1.3

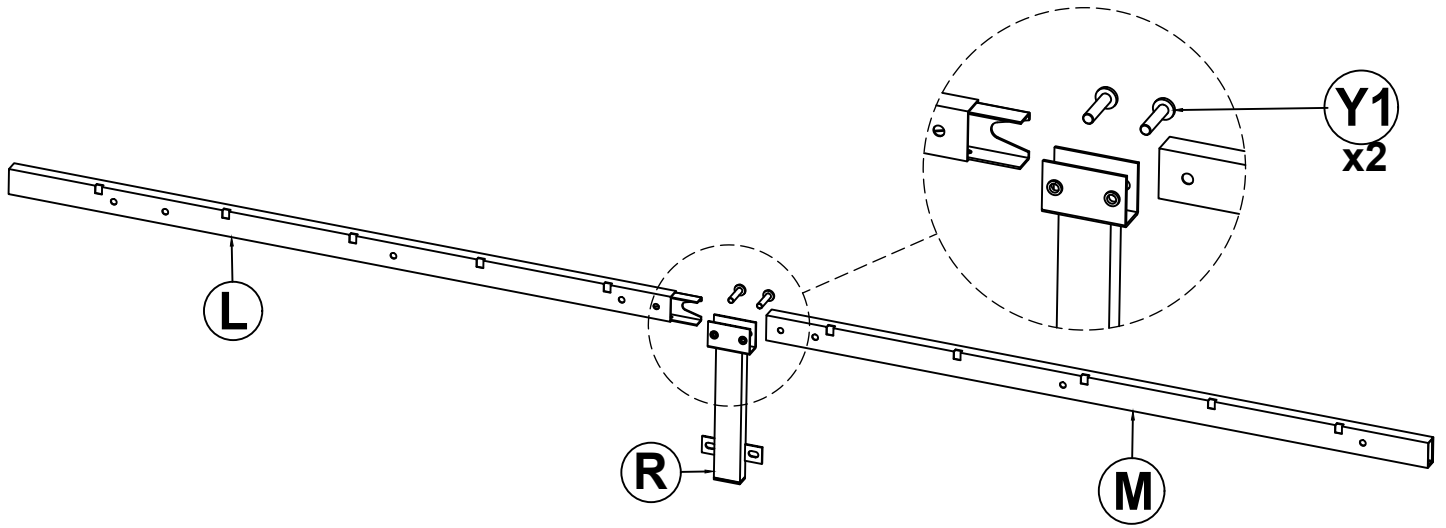

2.1

Step 2

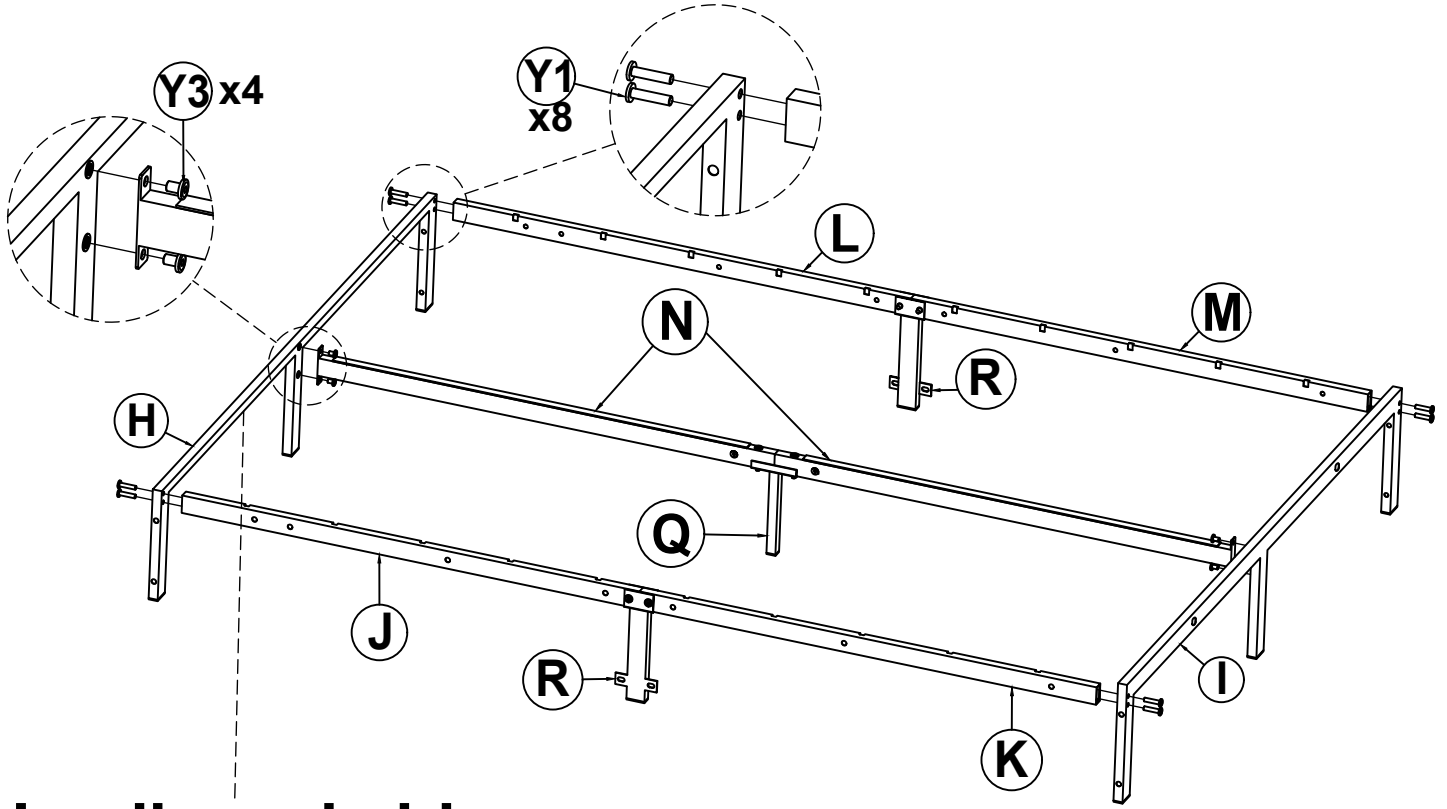

Headboard side

2.2

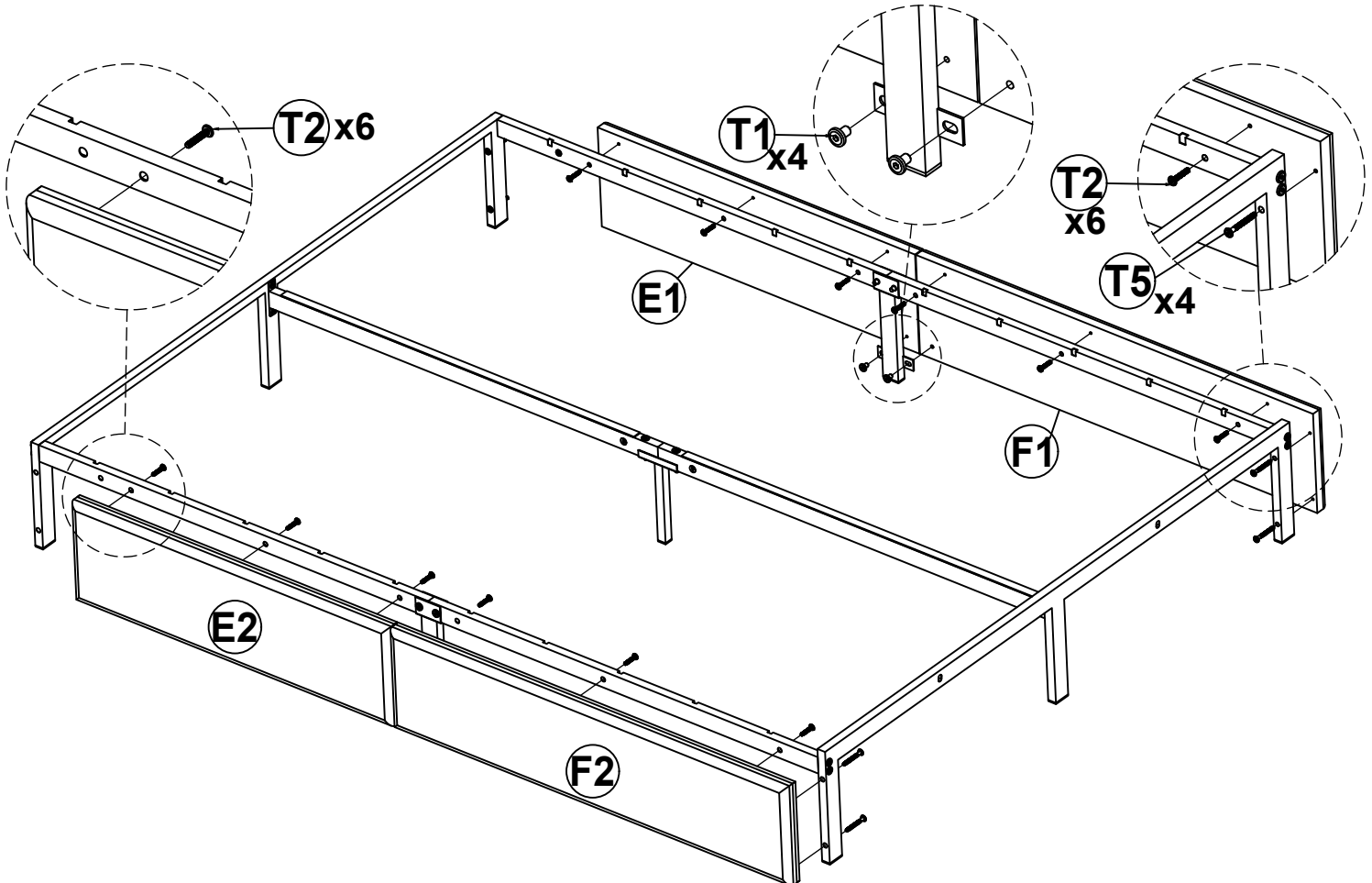

Step 3

3.1

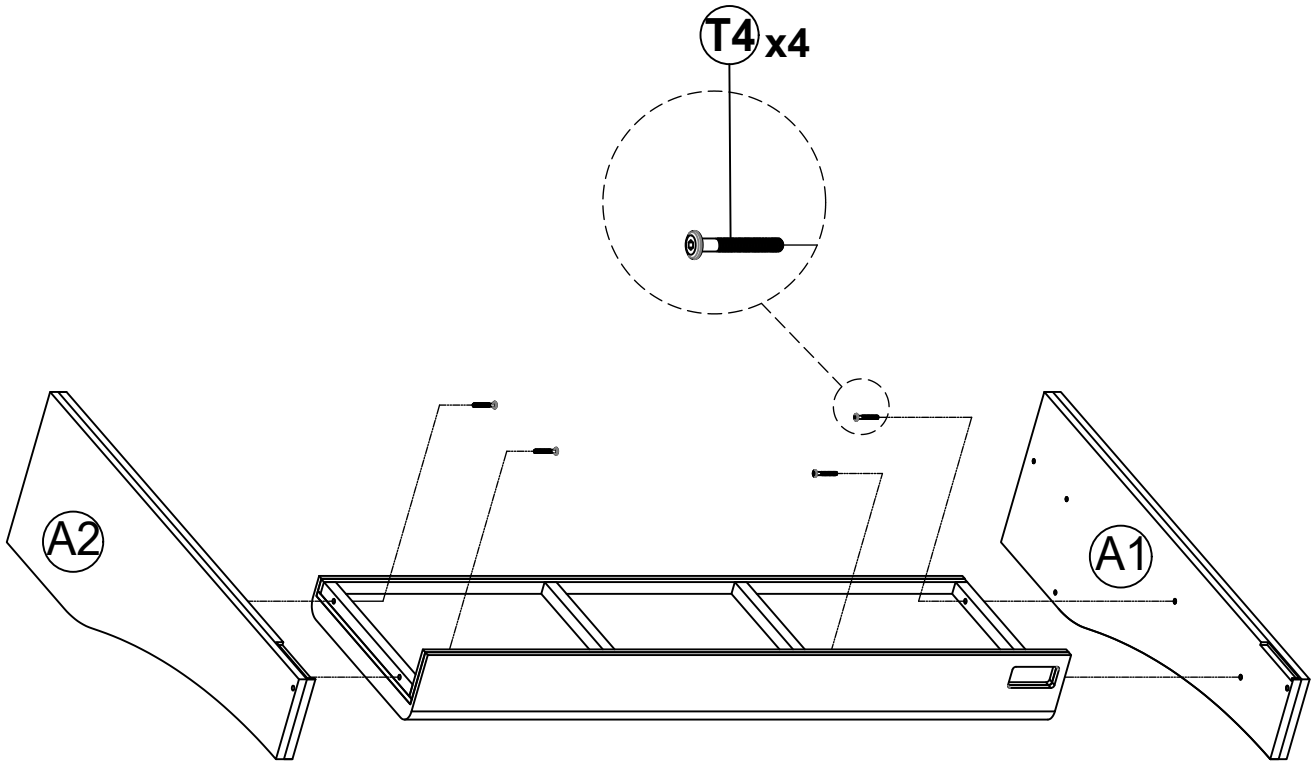

3.2

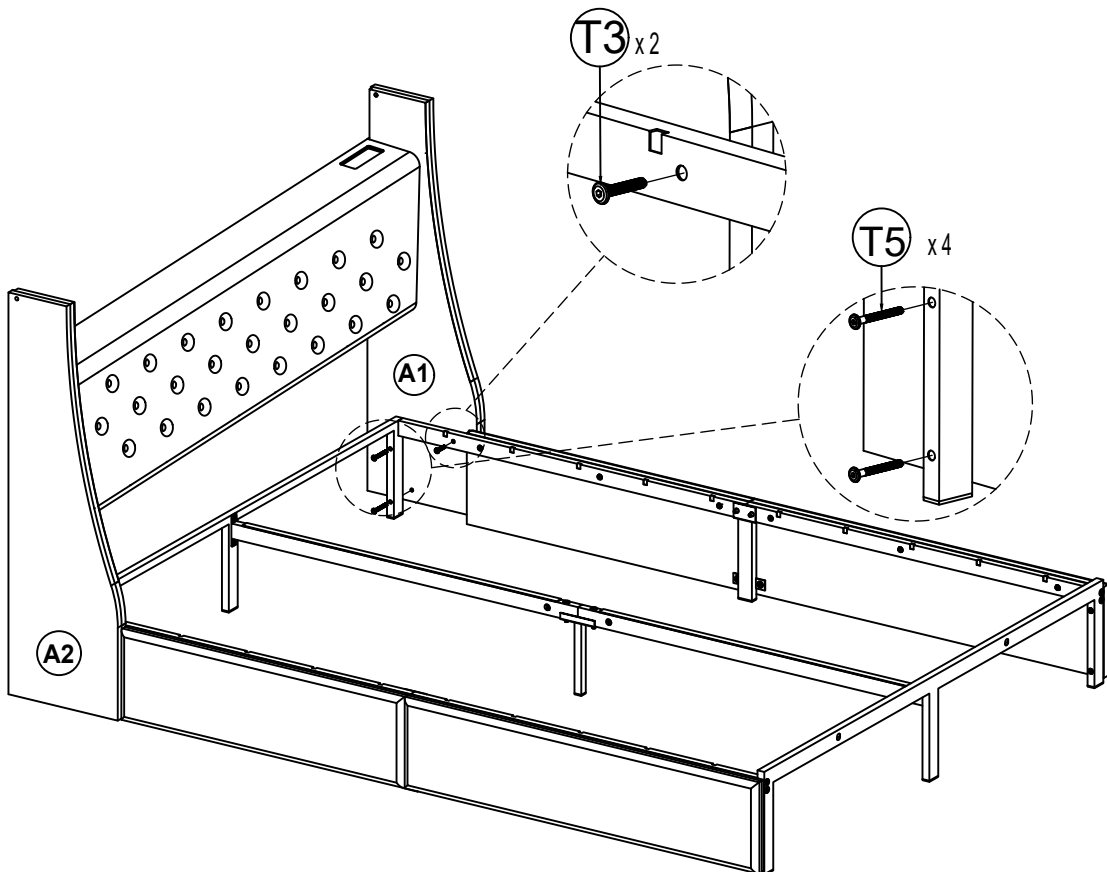

Step 4

4.1

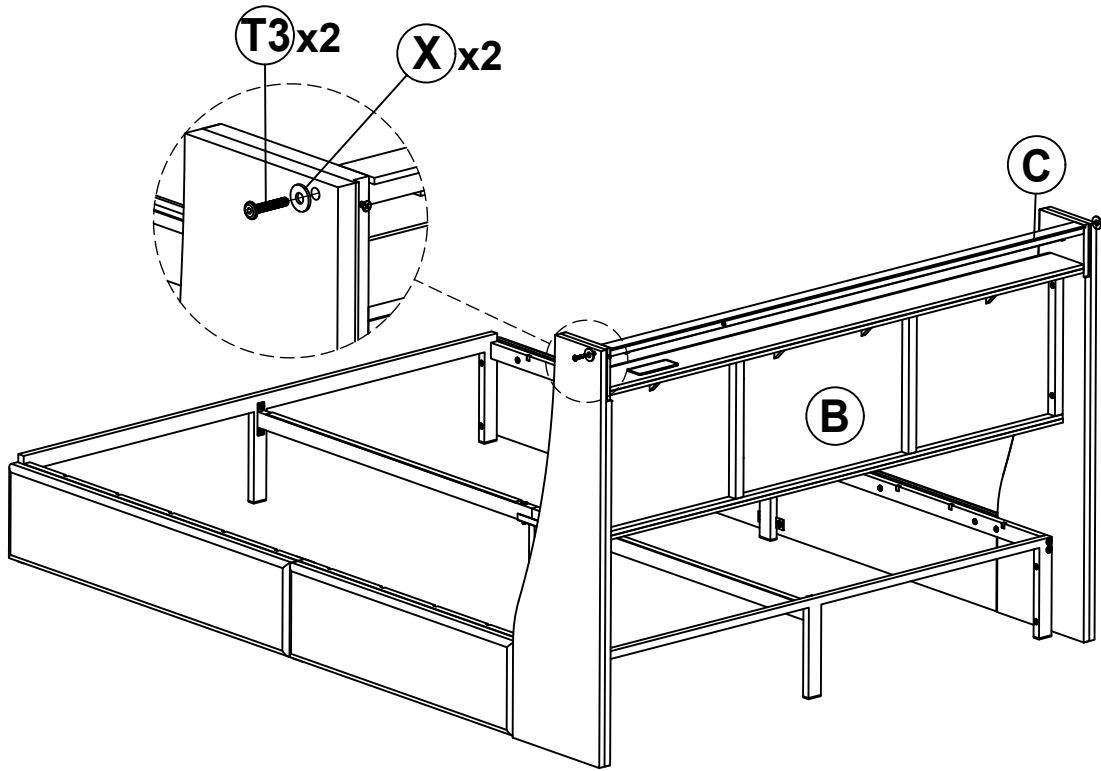

4.2

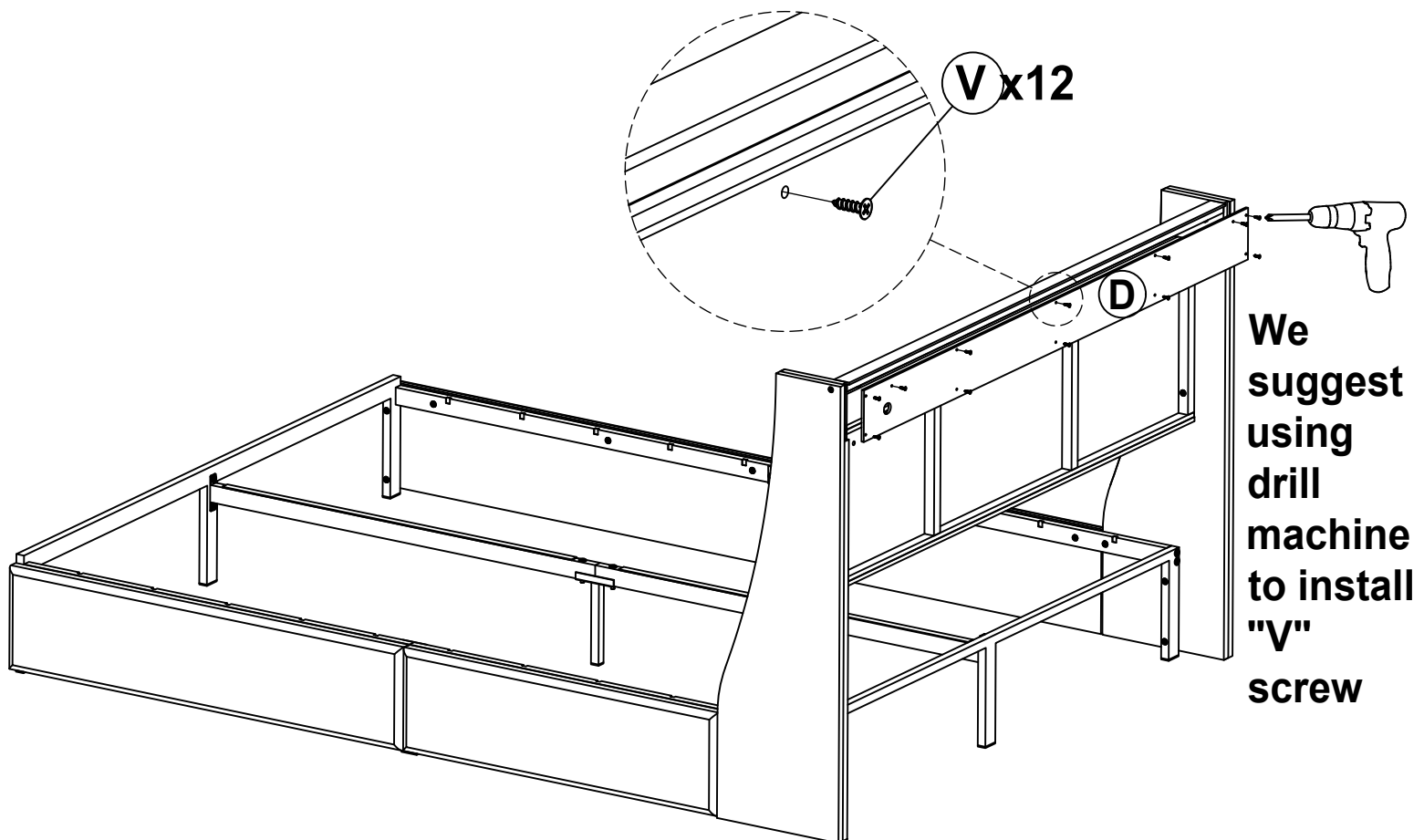

Step 5

Tear off the double-sided adhesive tape before place the mattress.

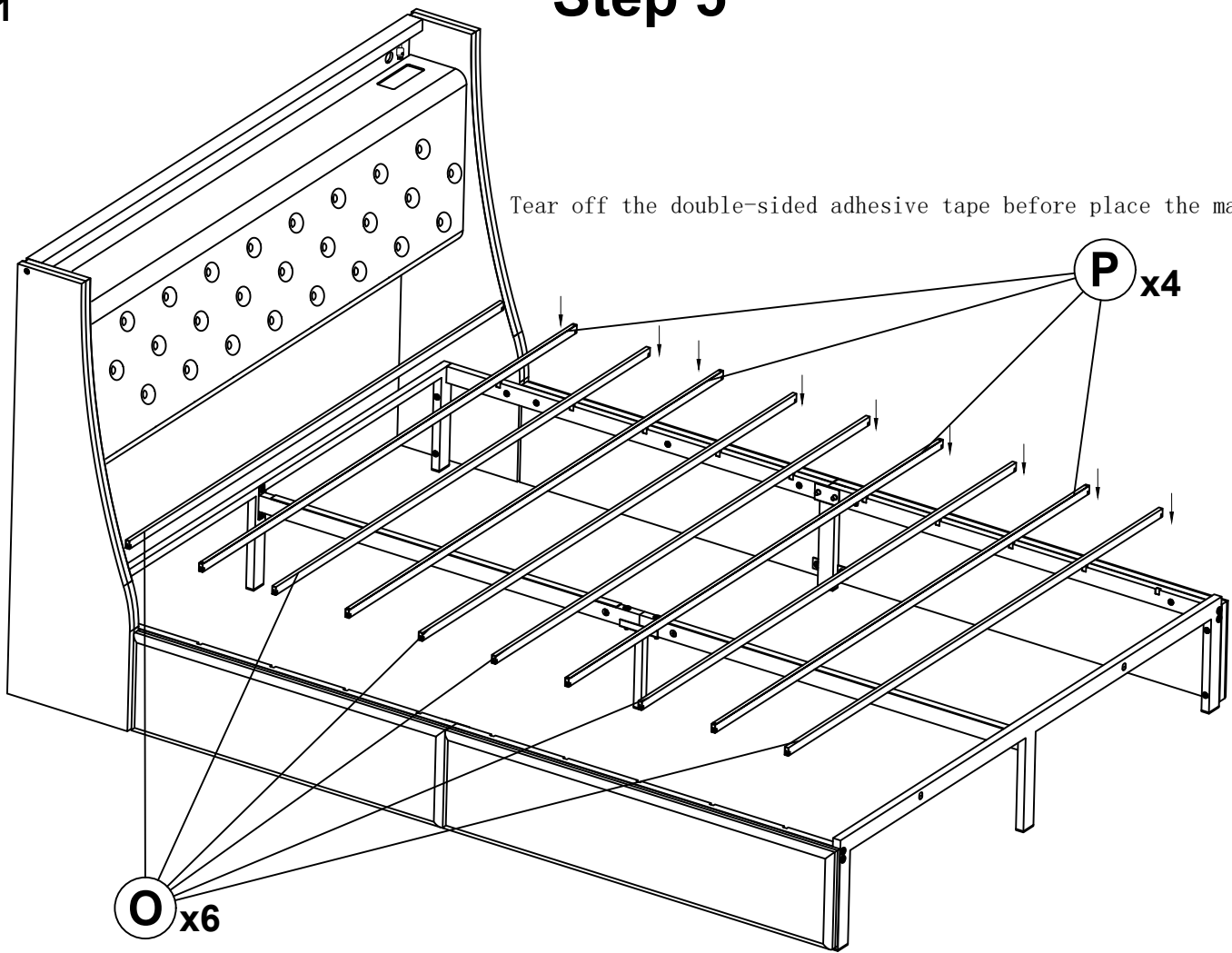

Step 6

Put all the screw in but not tighten, don't let the screws get through all the wheel's holder

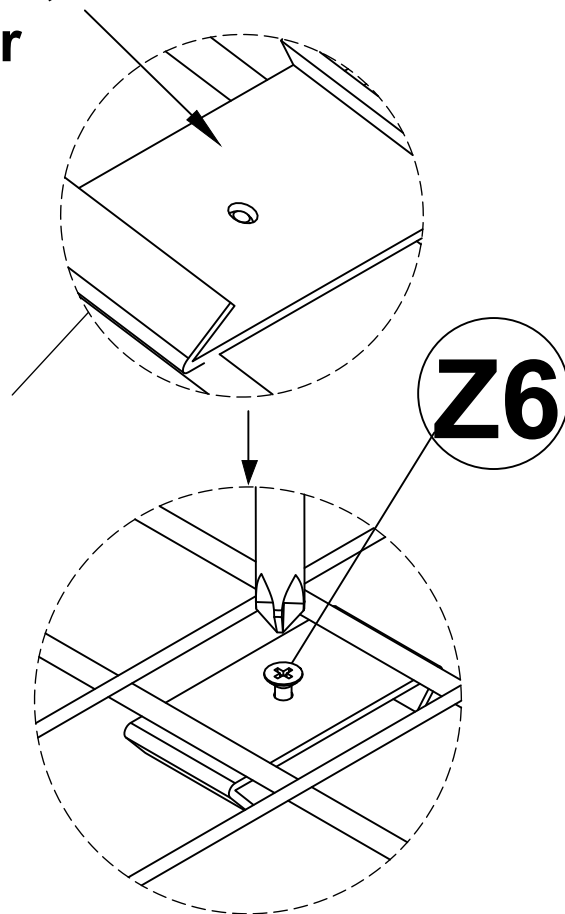
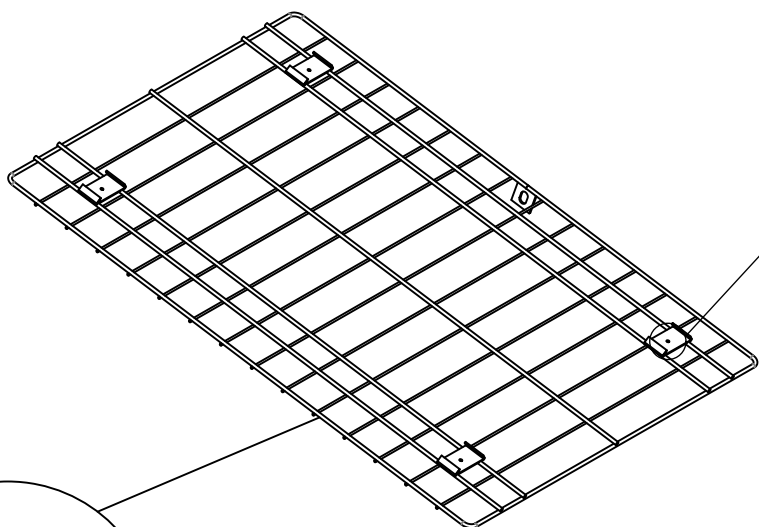

Slide in

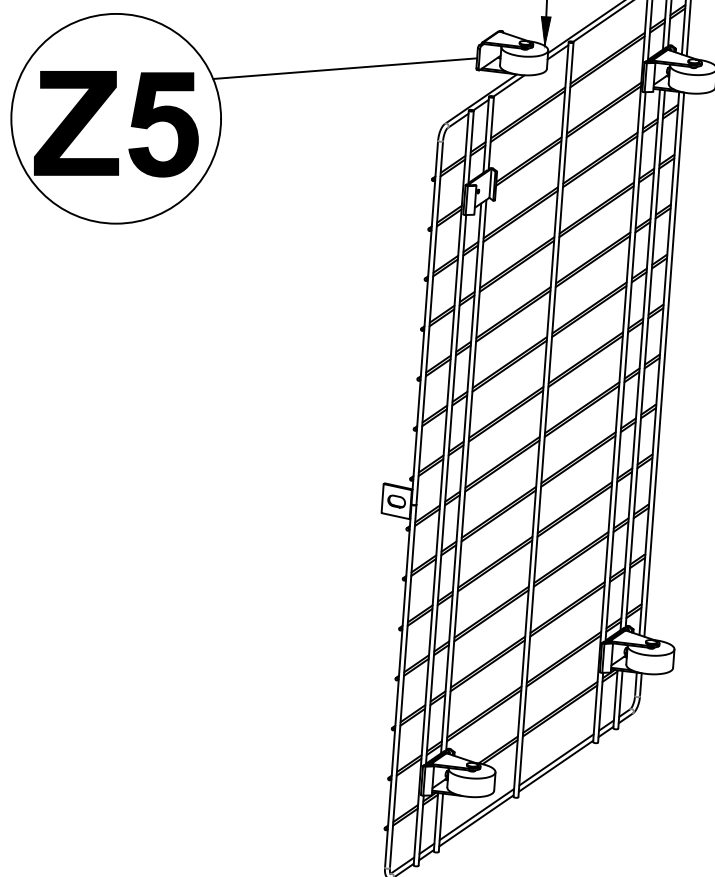

Re-tighten the screws

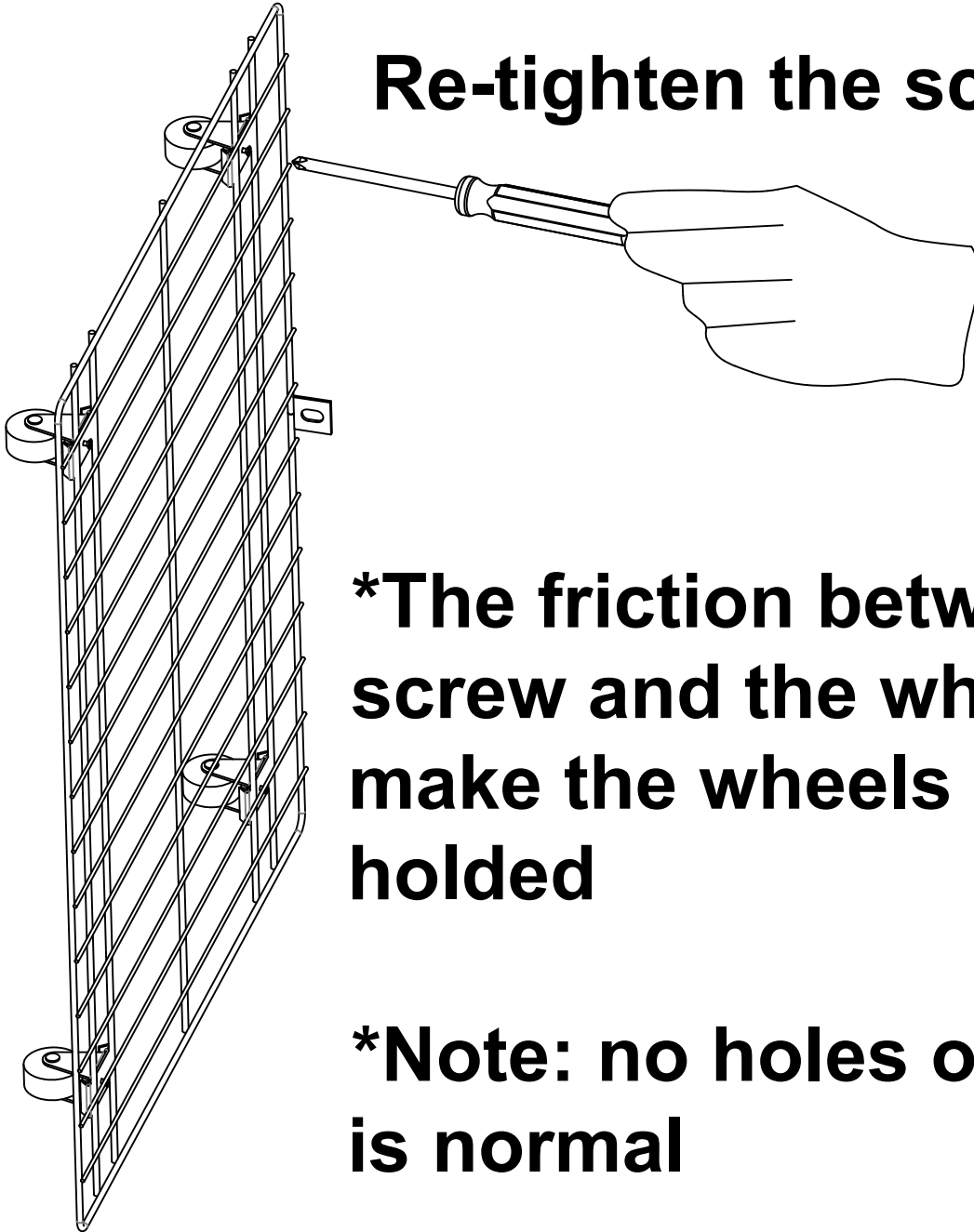

***The friction between the screw and the wheels will make the wheels can be holded**

***Note: no holes on the wheels is normal**

Detailed assembly instructions Q1

these two
lines on Q1.1
and Q1.2 need
to be matched

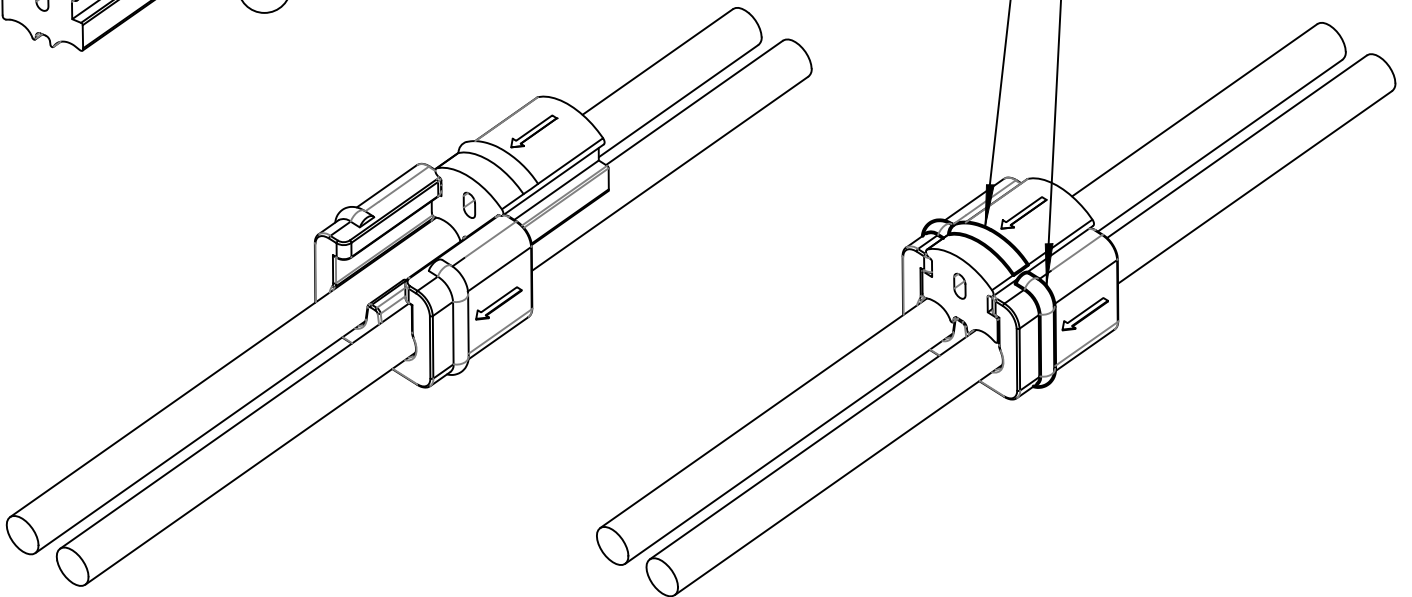
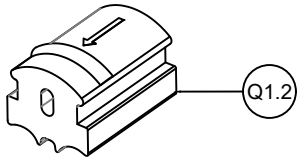
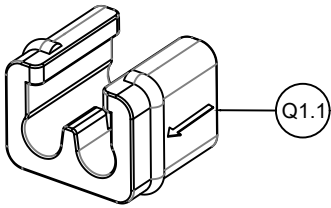

7.1

Step 7

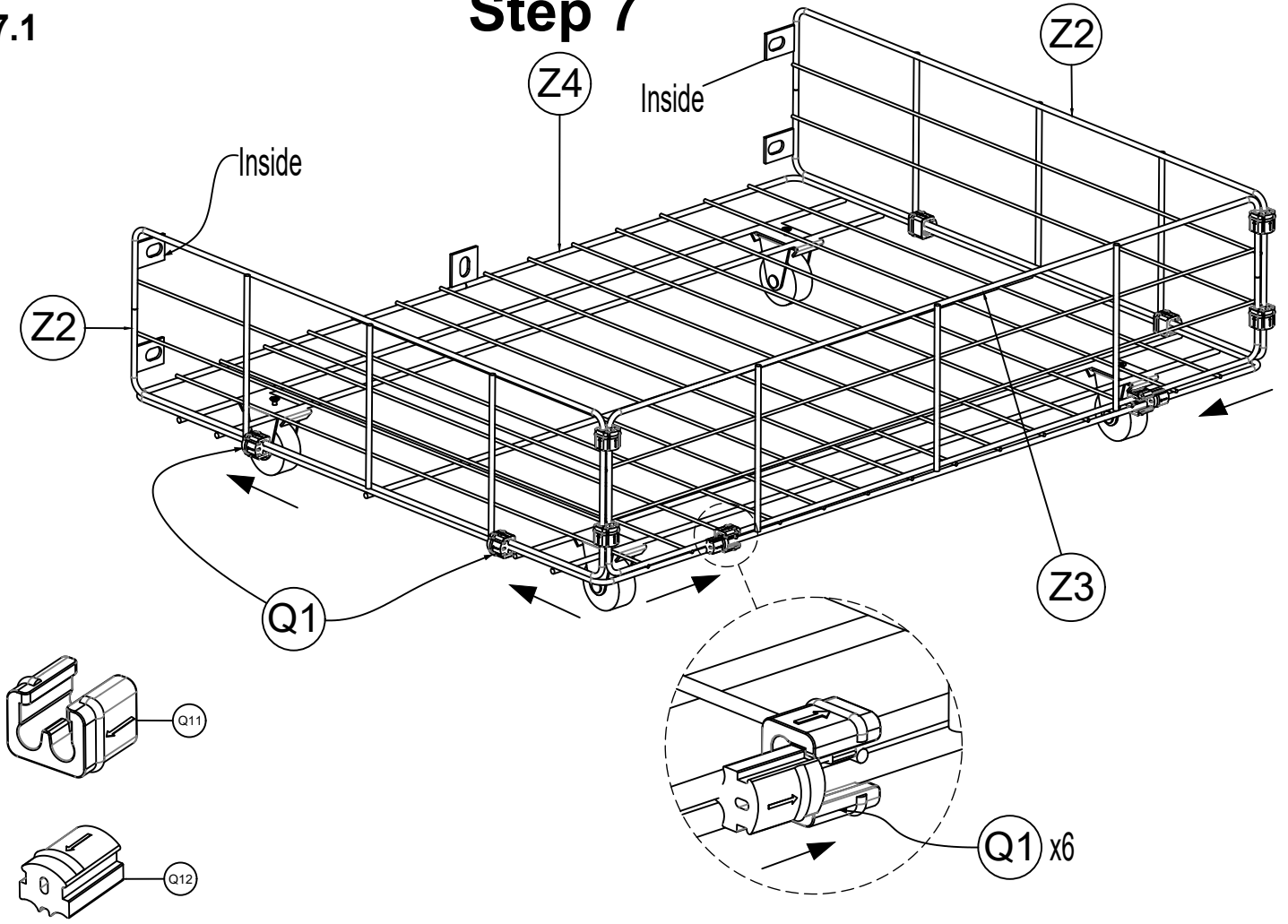

7.2

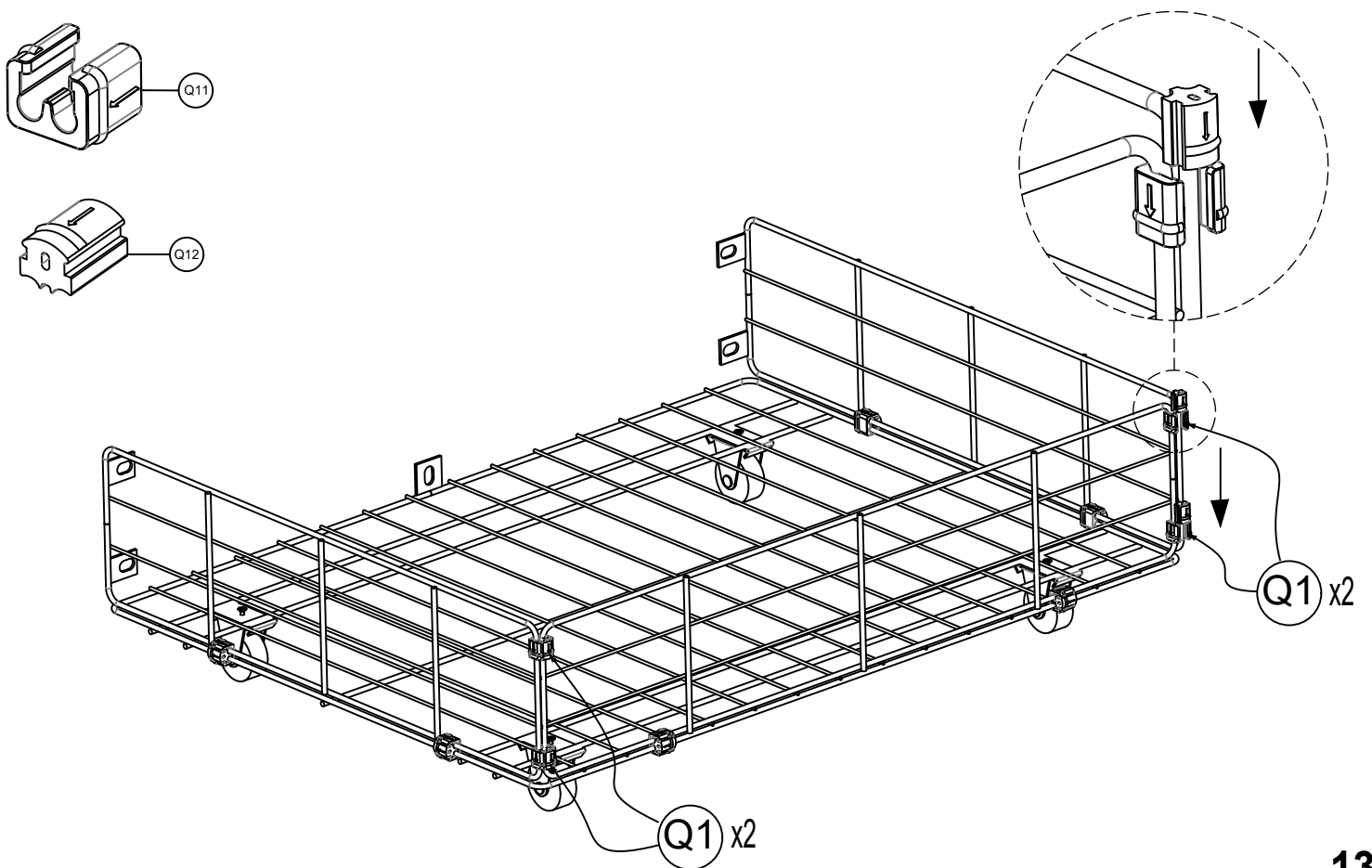

8.1

Step 8

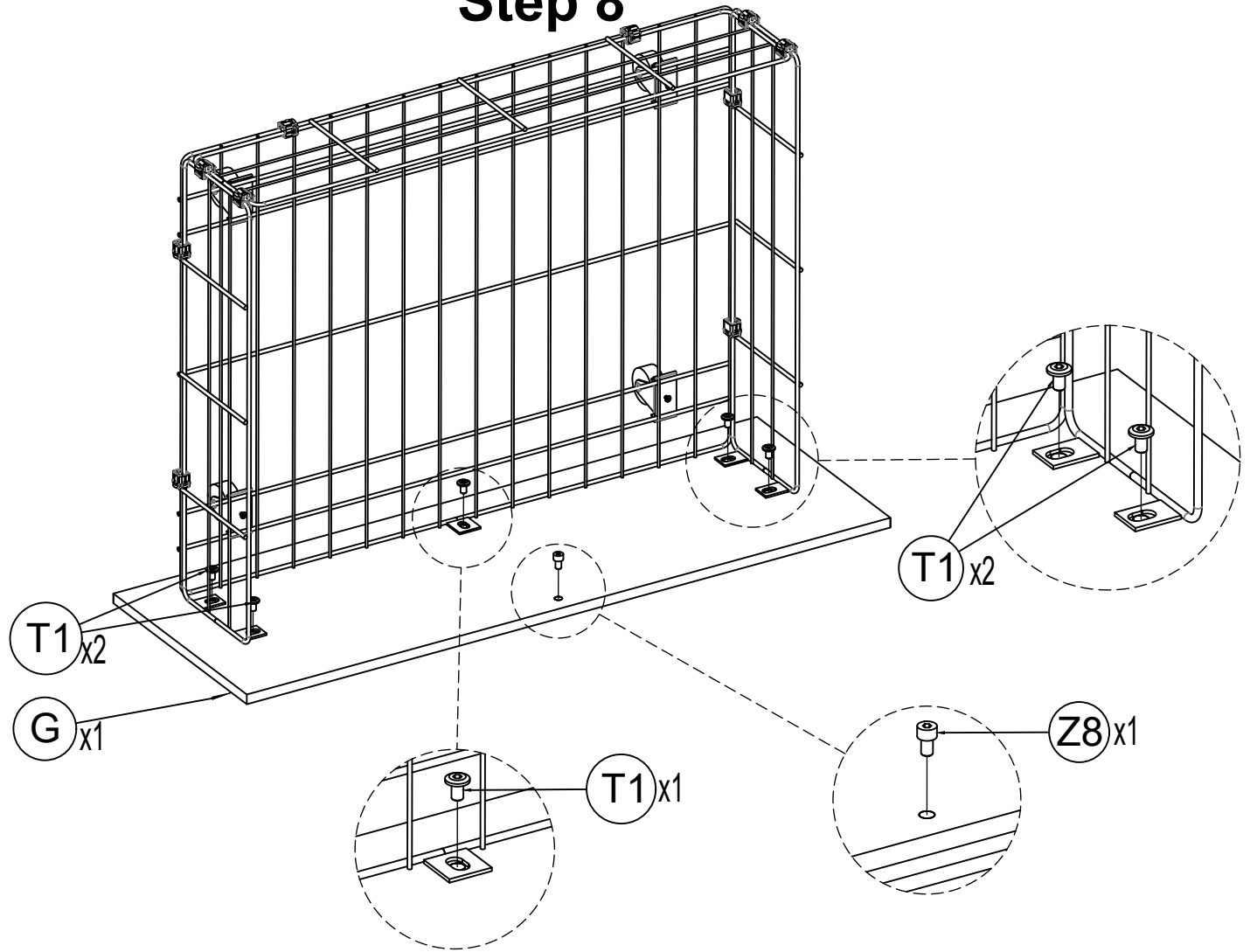

8.2

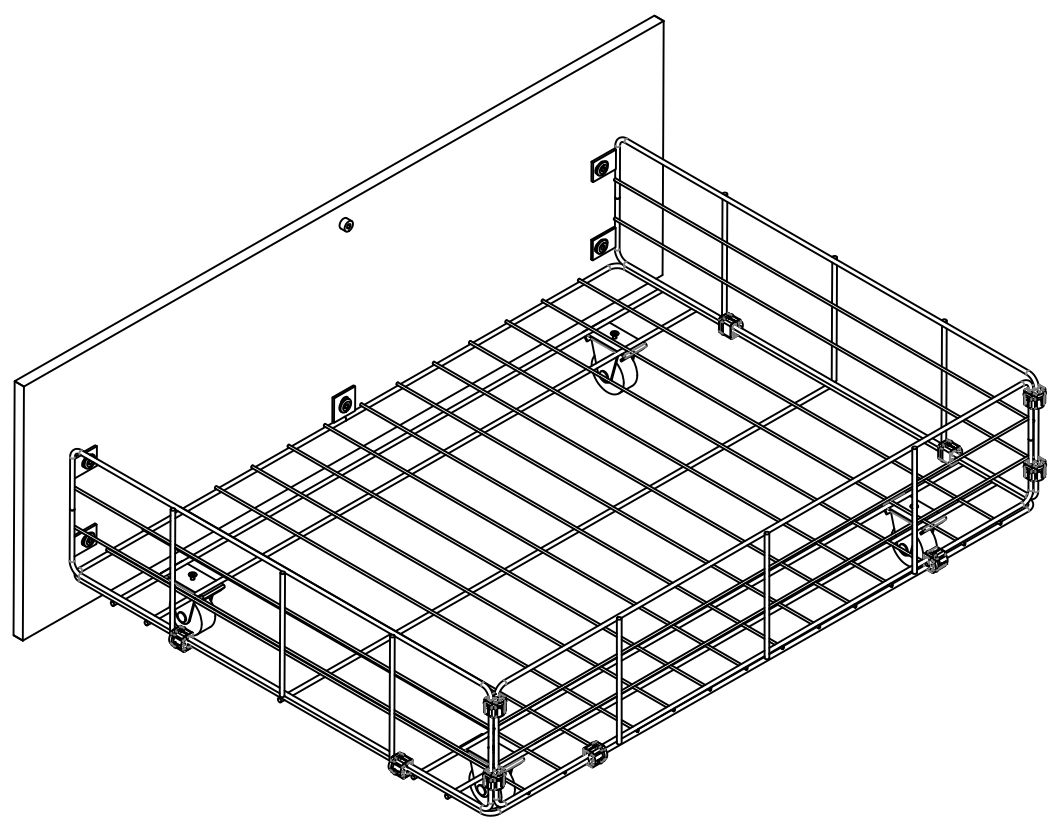

Step 9

2pcs

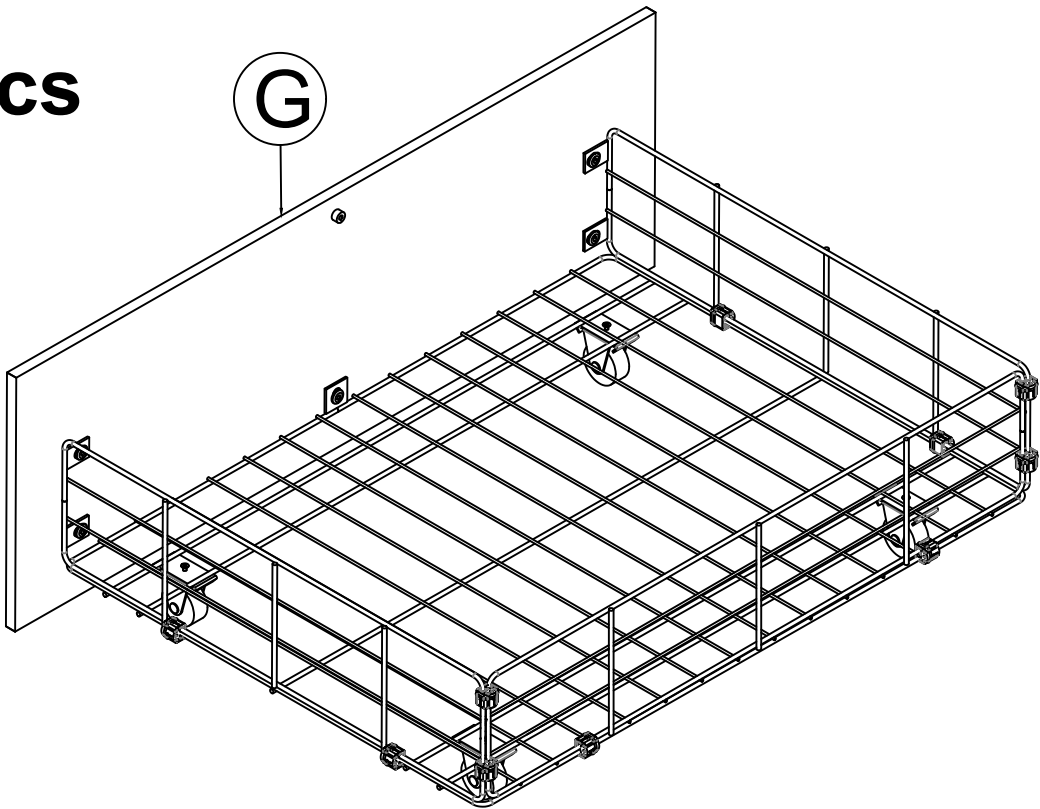

U1 X1

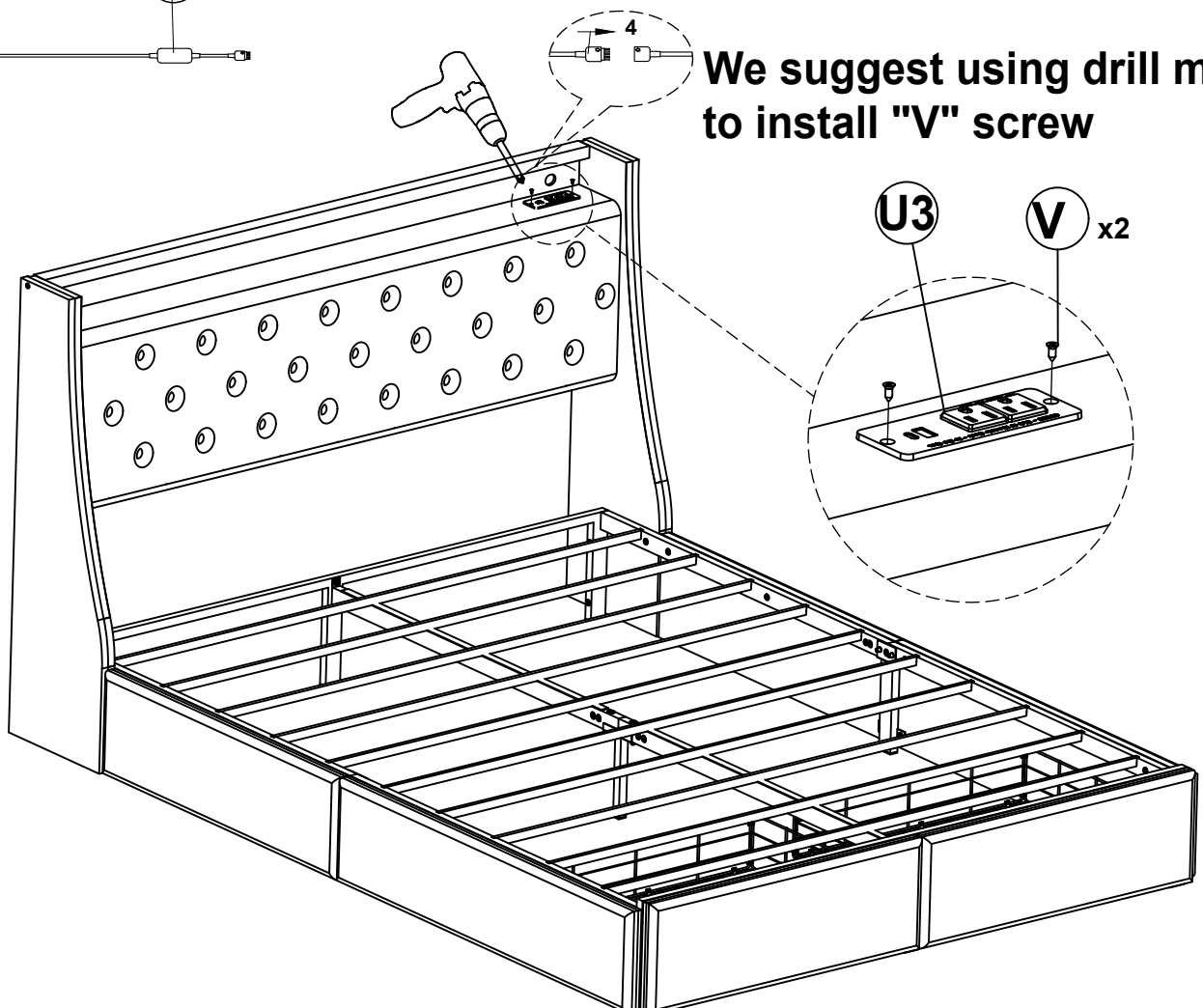

We suggest using drill machine to install "V" screw

U3

V x2

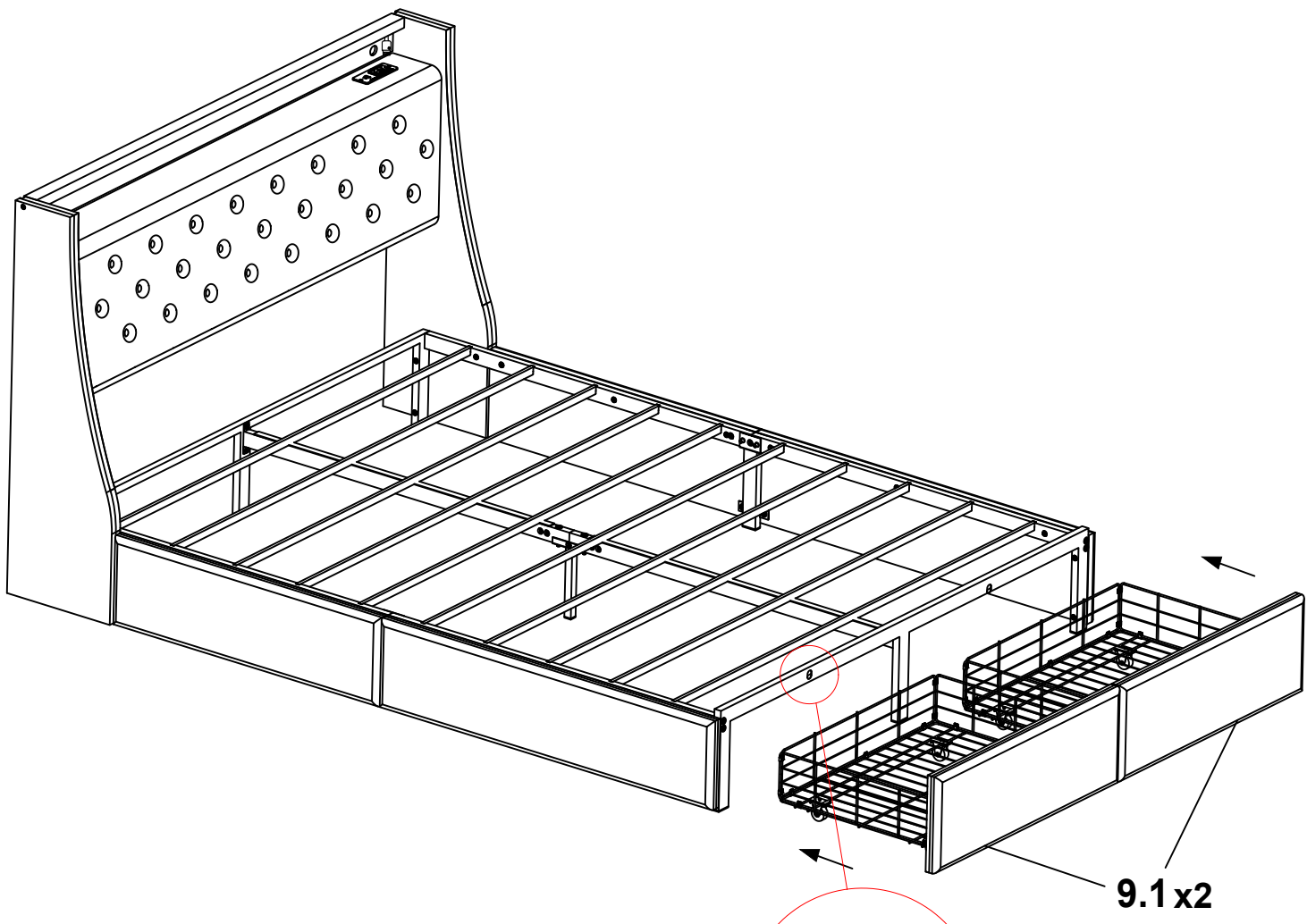

9.1x2

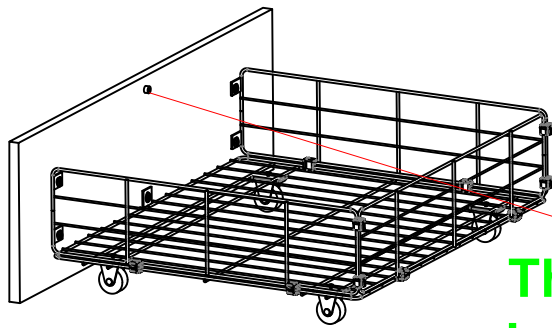

The screw head is inserted into this hole to help fix the drawer

REMOTE CONTROL

