

ASSEMBLY INSTRUCTIONS

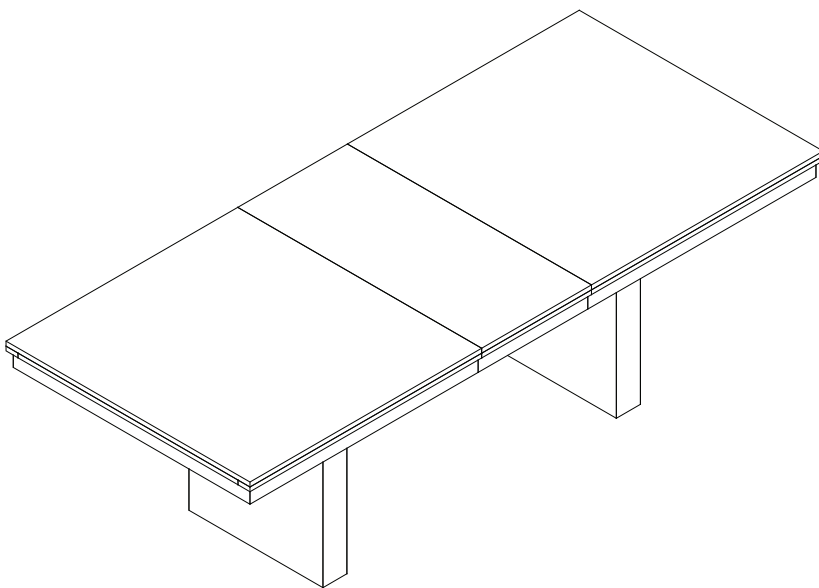

TOOLS REQUIRED



Allen Wrench

(Included)



Phillips Screwdriver

(Not Included)



2 - People
Recommended

ASSEMBLY RATING



EASY —————> DIFFICULT

The Assembly Rating is a 5-point system showing the level of effort needed to assemble a specific product.



CHECK BEFORE STARTING

Are you missing anything?

Double-check all parts, hardware and accessories listed are all accounted for.

Check out our Quick Tips!

We recommend reviewing the pre-assembly handouts. Even experts need a refresher now and then!

Should we send any replacements?

Are there any irregularities or flaws in the parts? We can send replacements!

Prep Time!

Please review the assembly instructions and all diagrams prior to assembling.

PRE ASSEMBLY INTRODUCTION

We understand building ready-to-assemble furniture can be a challenging experience for some. To help avoid confusion, we have provided some helpful tips that may speed up the process.

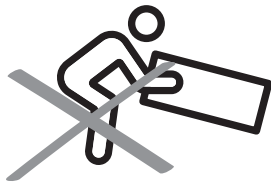

Teamwork

ALWAYS have at least two people to help with transporting and assembling the product to avoid potential injury and/or damage.

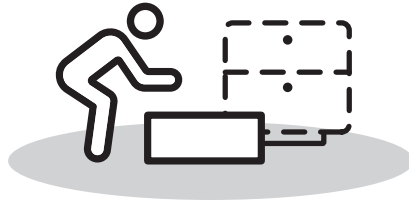
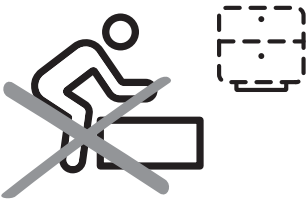

Suitable Location

Assembling near the area of the intended location is highly recommended.



Sufficient Space

Make sure you have enough space to move around during the assembly.

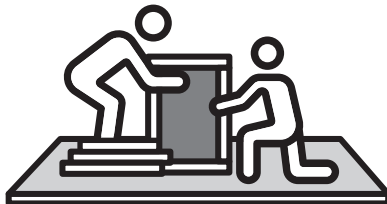

Avoid Scratches

Use cardboard, blankets or a carpeted area while assembling furniture to prevent to prevent scratches and damages.

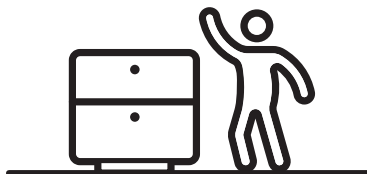
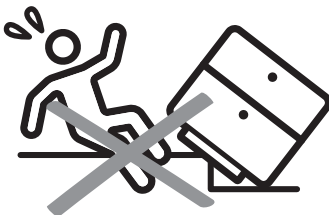

Flat Surface

Make sure the furniture rests on a flat and level surface with each leg evenly touching the floor.

ASSEMBLY AND CARE ADVICE



FAILURE TO FOLLOW THE GUIDELINES BELOW MAY RESULT IN INJURY AND/OR PROPERTY DAMAGE.



Position each part correctly and insert screws or bolts into their respective holes.

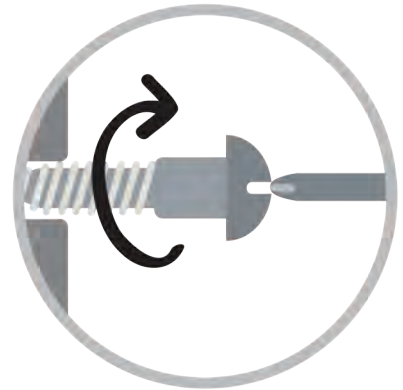

Turn clockwise to tighten and only tighten when step is completed or when instructed to do so.



Use the appropriate hand tools or power tools for assembly. Select steps, such as tightening screws and/or bolts, may require hand tools to avoid causing damage during assembly.



Save the instructions and store any supplied tools for later maintenance.



After two weeks, check and tighten any loose hardware and repeat again every six months thereafter.

IT IS THE USER'S RESPONSIBILITY TO MAINTAIN THE FURNITURE. THE HARDWARE MAY LOOSEN OVER TIME AND MAY CAUSE THE FURNITURE TO BE WOBBLY AND UNABLE TO SUPPORT ITS INTENDED WEIGHT CAPACITY. THIS MAY LEAD TO COLLAPSE AND MAY CAUSE SERIOUS INJURY.

DINING TABLE

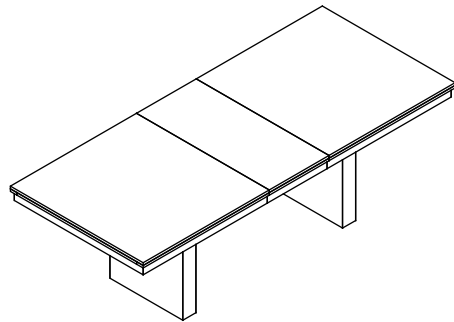
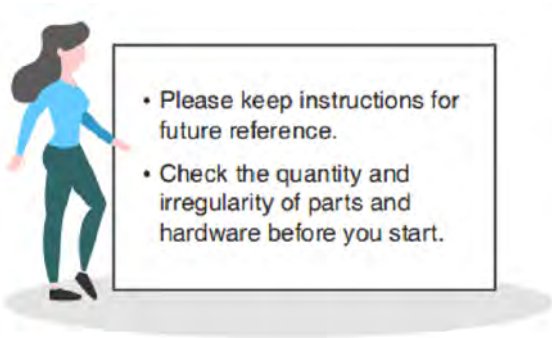

PARTS

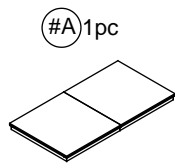
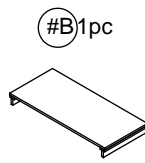

Table Top



Leaf



Legs



Stretcher



Mounting Plate

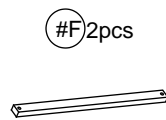

Mounting Plate Leaf

HARDWARE



Bolt $\varnothing 5/16"$ x 45mm



Nut $\varnothing 5/16"$ x 12mm



Spring washer $\varnothing 5/16"$



Flat washer $\varnothing 5/16"$ x 19mm

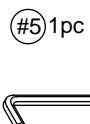



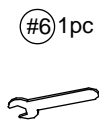



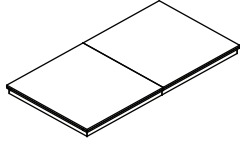

Allen key 4mm

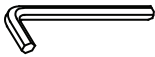
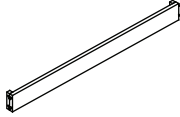

Open Wrench (1/2")

packed in 2 cases

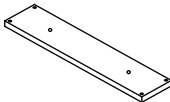
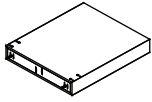
Carton	Disignation		Part	Hardware
1	Table Top (1pc)	#A		 #1 20pcs  #2 4pcs  #3 24pcs  #4 24pcs
	Leaf (1pc)	#B		 #5 1pc
	Stretcher (2pcs)	#D		 #6 1pc
	Mounting Plate Leaf (2pcs)	#F		
	Mounting Plate (2pcs)	#E		
2	Legs (2pcs)	#C		

Exploded View

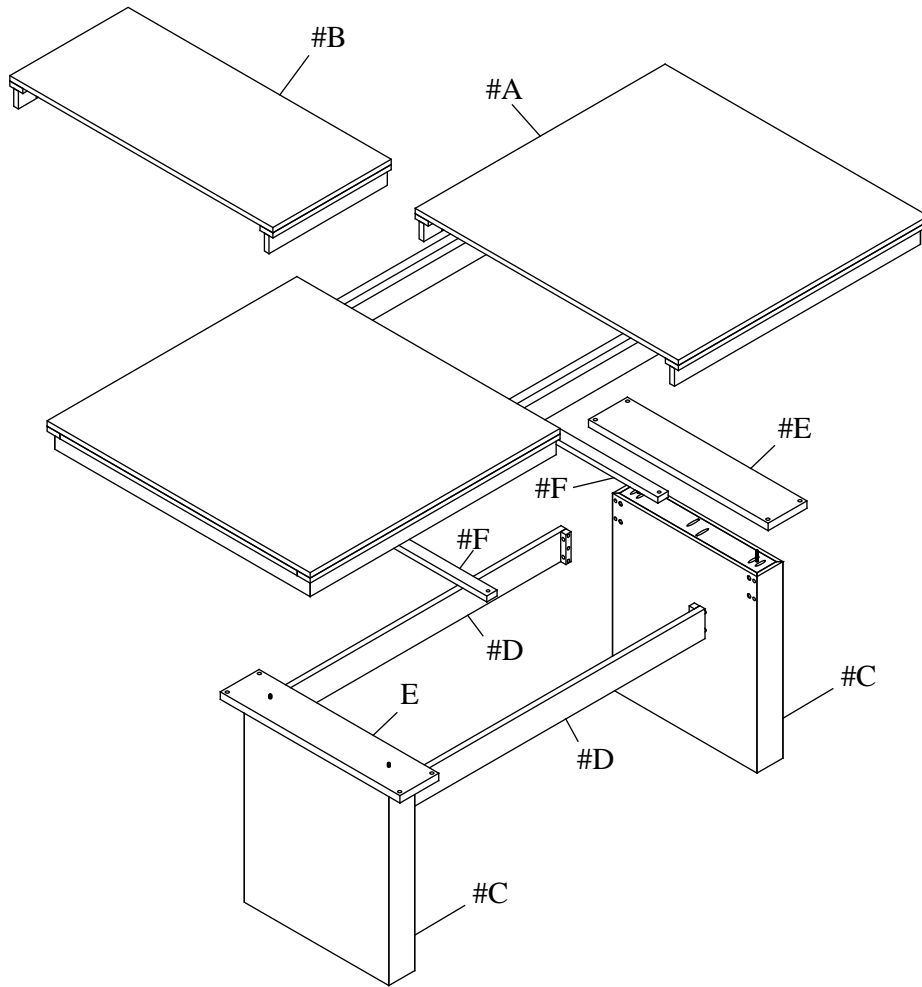

ASSEMBLY INSTRUCTIONS

Align mounting plate (#E) to the legs (#C), then secure by using bolts (#2) with washers (#3,#4).

1

Part #C x2pcs

Part #E x2 pcs

Hardware #2 x4pcs

Hardware #3 x4pcs

Hardware #4 x4pcs

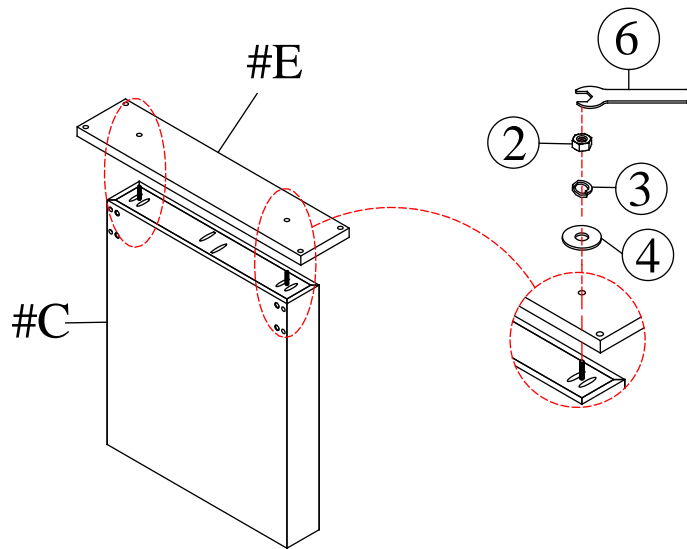

Align legs, mounting plate, mounting plate leaf (#C,#E,#F) to the table top (#A), then secure by using bolts (#1) with washers (#3,#4).

2

Part #A x1pc

Hardware #1 x12pcs

Hardware #3 x12pcs

Hardware #4 x12pcs

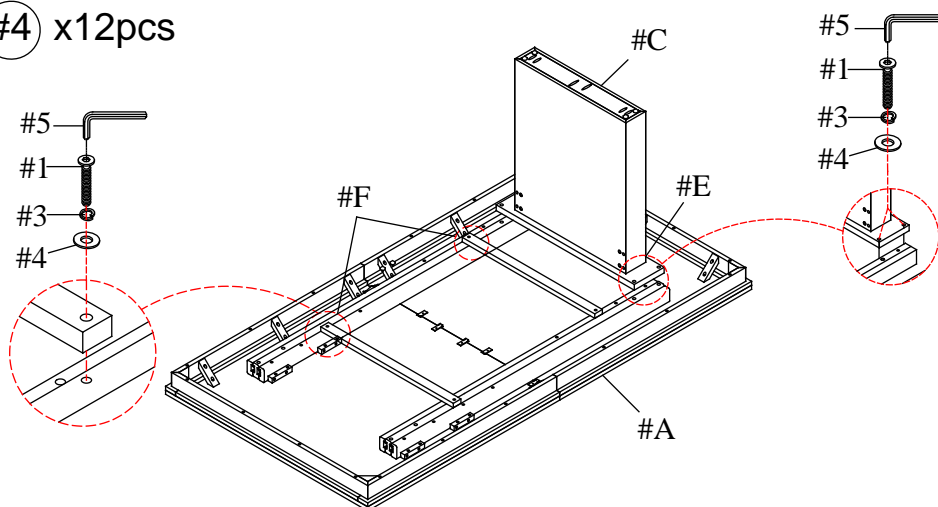

ASSEMBLY INSTRUCTIONS

3

Align stretcher (#D) to the legs (#C), then secure by using bolts (#1) with washers (#3,#4).

Part (#D) x2pcs

Hardware (#1) x8pcs

Hardware (#3) x8pcs

Hardware (#4) x8pcs

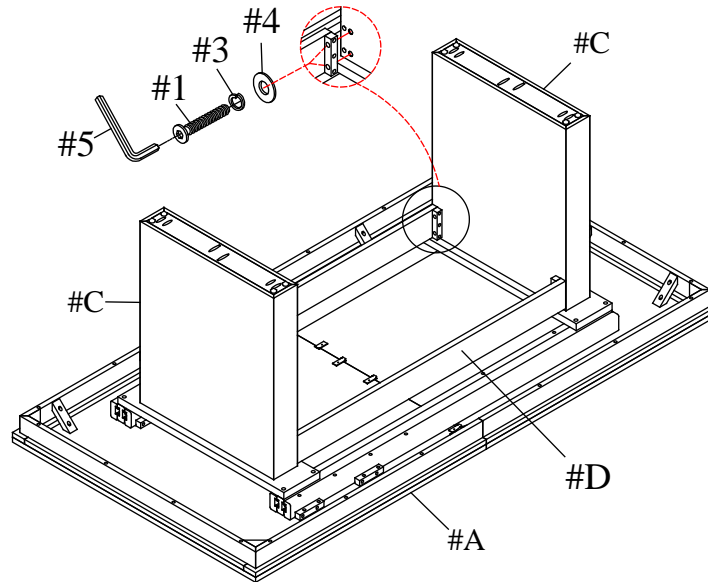

4

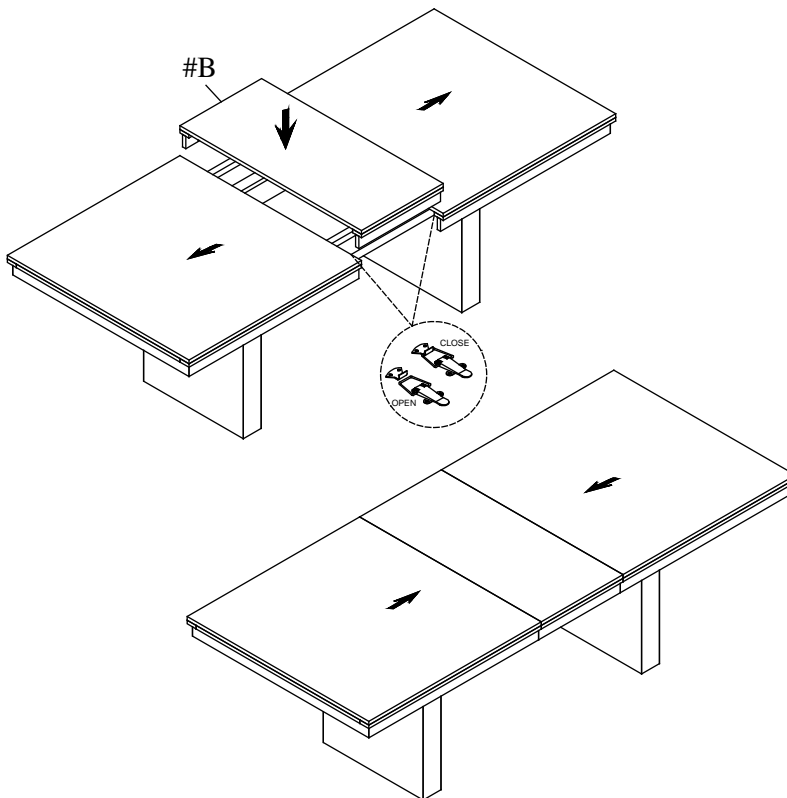

ASSEMBLY COMPLETED



Please ensure the furniture rests on an even and flat surface. If the product wobbles or feels loose, double-check all bolts and/or screws are properly tightened and secured.



Keep this handy!

Please retain this instruction manual and any order-related information for future reference.



Lift, don't drag!

To avoid damage to product please always LIFT the product when transporting or adjusting the placement.

This product is intended for RESIDENTIAL USE ONLY and not for commercial use.

ASSEMBLY INSTRUCTIONS

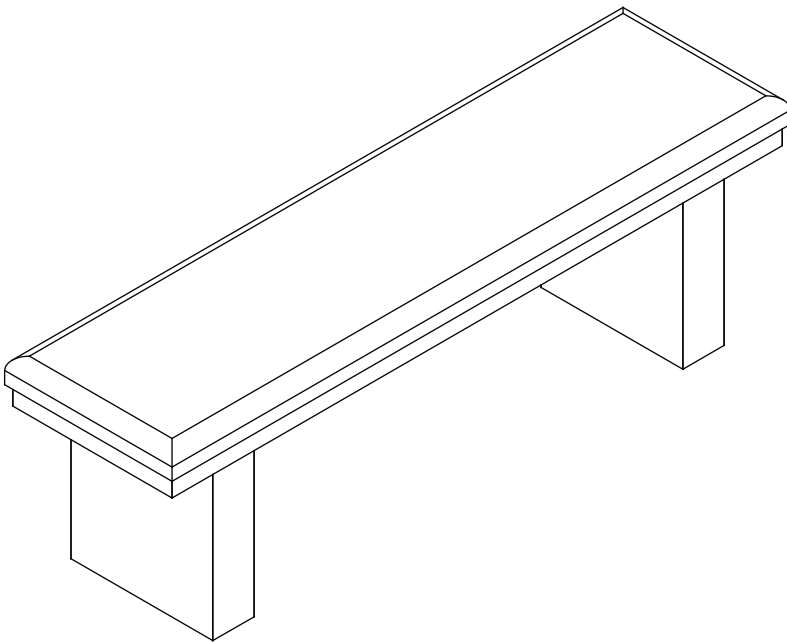

TOOLS REQUIRED



Allen Wrench

(Included)



**Phillips
Screwdriver**

(Not Included)



**2 - People
Recommended**

ASSEMBLY RATING



EASY —————> **DIFFICULT**

The Assembly Rating is a 5-point system showing the level of effort needed to assemble a specific product.



CHECK BEFORE STARTING

Are you missing anything?

Double-check all parts, hardware and accessories listed are all accounted for.

Check out our Quick Tips!

We recommend reviewing the pre-assembly handouts. Even experts need a refresher now and then!

Should we send any replacements?

Are there any irregularities or flaws in the parts? We can send replacements!

Prep Time!

Please review the assembly instructions and all diagrams prior to assembling.

PRE ASSEMBLY INTRODUCTION

We understand building ready-to-assemble furniture can be a challenging experience for some. To help avoid confusion, we have provided some helpful tips that may speed up the process.

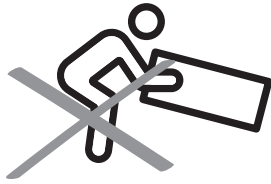

Teamwork

ALWAYS have at least two people to help with transporting and assembling the product to avoid potential injury and/or damage.

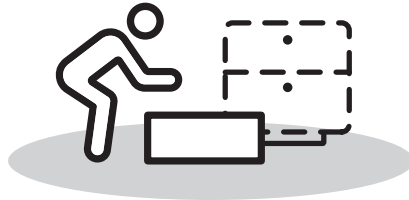
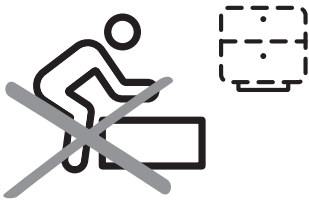

Suitable Location

Assembling near the area of the intended location is highly recommended.



Sufficient Space

Make sure you have enough space to move around during the assembly.

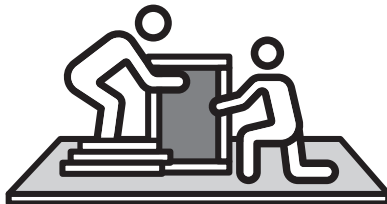

Avoid Scratches

Use cardboard, blankets or a carpeted area while assembling furniture to prevent to prevent scratches and damages.

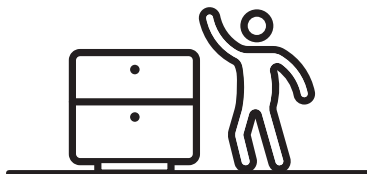
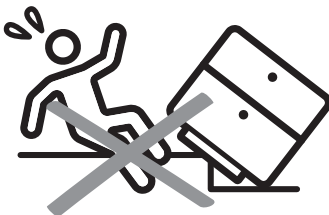

Flat Surface

Make sure the furniture rests on a flat and level surface with each leg evenly touching the floor.

ASSEMBLY AND CARE ADVICE



FAILURE TO FOLLOW THE GUIDELINES BELOW MAY RESULT IN INJURY AND/OR PROPERTY DAMAGE.



Position each part correctly and insert screws or bolts into their respective holes.

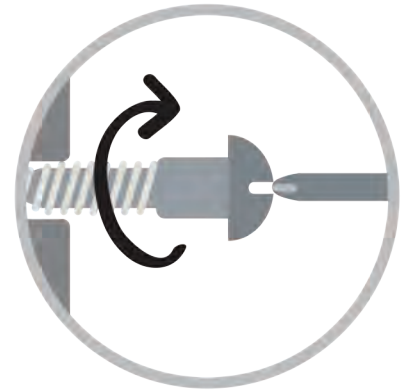

Turn clockwise to tighten and only tighten when step is completed or when instructed to do so.



Use the appropriate hand tools or power tools for assembly. Select steps, such as tightening screws and/or bolts, may require hand tools to avoid causing damage during assembly.



Save the instructions and store any supplied tools for later maintenance.



After two weeks, check and tighten any loose hardware and repeat again every six months thereafter.

IT IS THE USER'S RESPONSIBILITY TO MAINTAIN THE FURNITURE. THE HARDWARE MAY LOOSEN OVER TIME AND MAY CAUSE THE FURNITURE TO BE WOBBLY AND UNABLE TO SUPPORT ITS INTENDED WEIGHT CAPACITY. THIS MAY LEAD TO COLLAPSE AND MAY CAUSE SERIOUS INJURY.

DINING BENCH

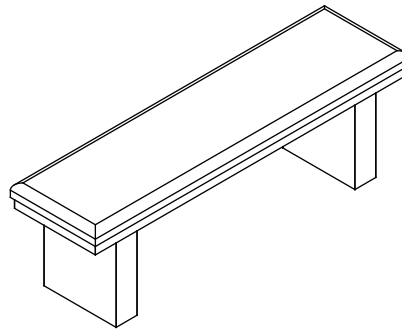
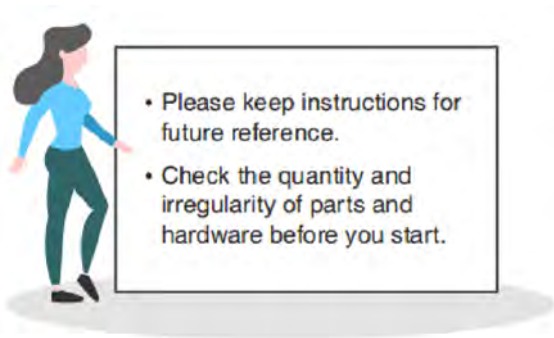

PARTS

#A) 1pc

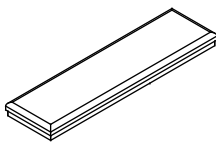

Bench Seat Frame

#B) 2pcs

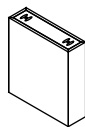

Legs

#C) 2pcs

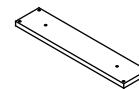

Mounting Plate

HARDWARE

#1) 12pcs



Bolt \varnothing 5/16" x 40mm

#2) 12pcs



Spring washer \varnothing 5/16"

#3) 12pcs



Flat washer \varnothing 5/16" x 19mm

#4) 1pc

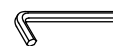

Allen key 4mm

Exploded View

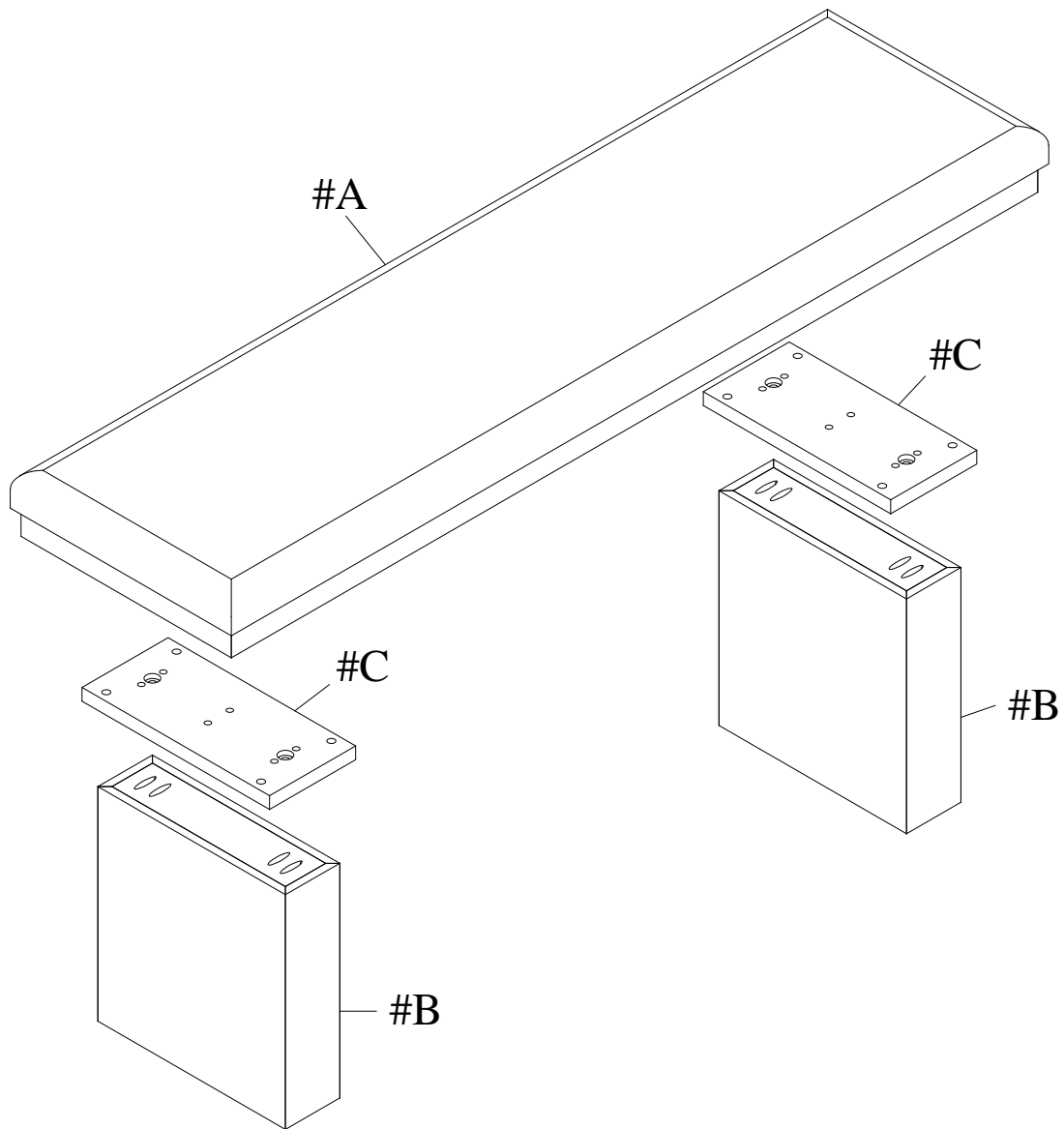

ASSEMBLY INSTRUCTIONS

1

Part #A x1pc

Part #B x2pcs

Hardware #1 x4pcs

Hardware #2 x4pcs

Hardware #3 x4pcs

Align mounting plate (#C) to the legs (#B), then secure by using bolts (#1) with washers (#2,#3).

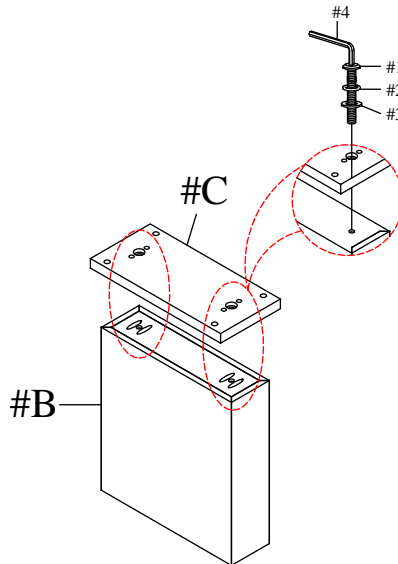

Part #A x1pc

Hardware #1 x8pcs

Hardware #2 x8pcs

Hardware #3 x8pcs

Align legs stretcher (#B,#C) to the Seat Frame (#A), then secure by using bolts (#1) with washers (#2,#3).

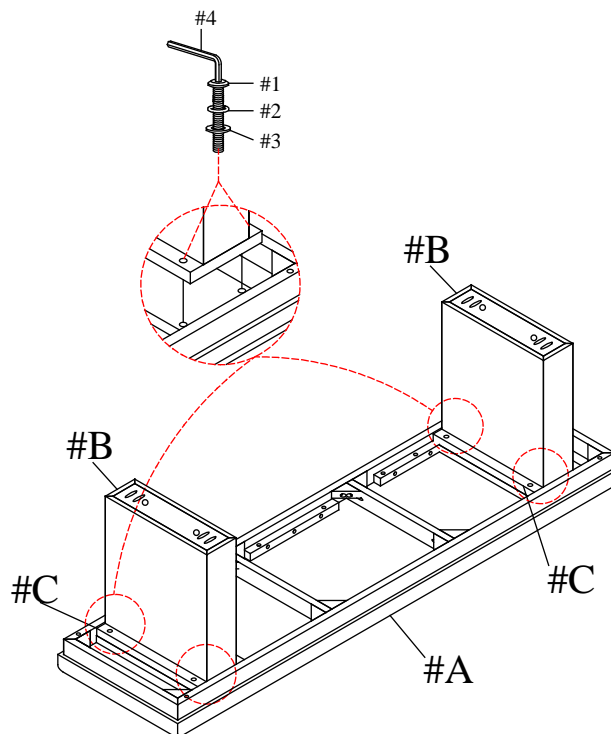

ASSEMBLY INSTRUCTIONS

3

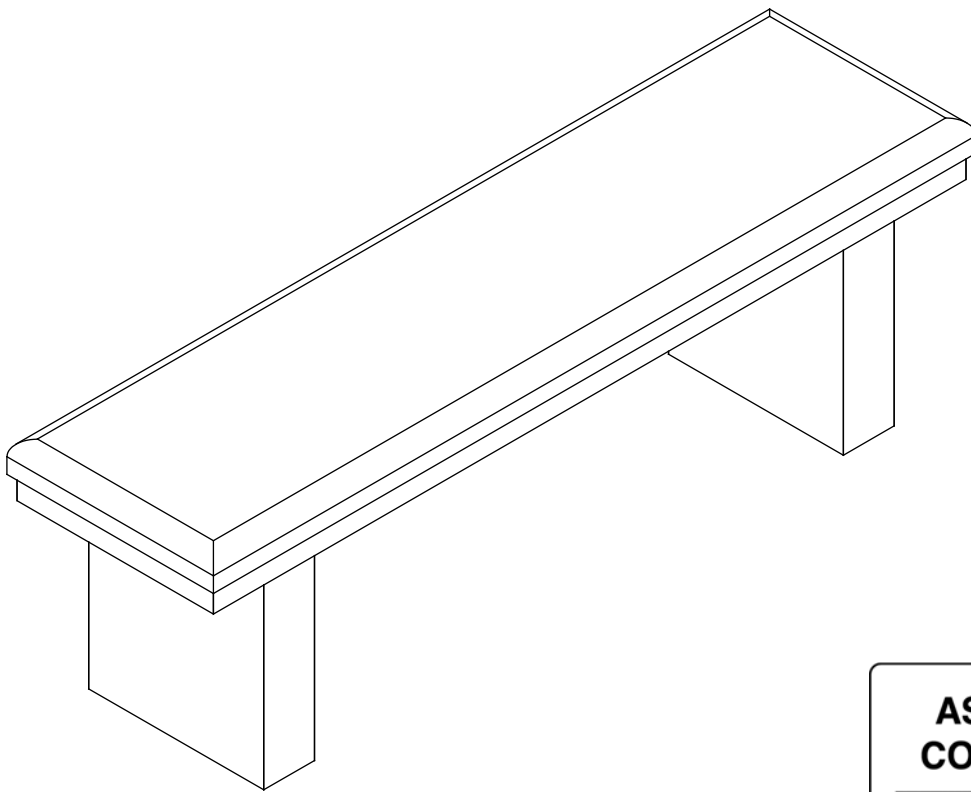

ASSEMBLY COMPLETED



Please ensure the furniture rests on an even and flat surface. If the product wobbles or feels loose, double-check all bolts and/or screws are properly tightened and secured.



Keep this handy!

Please retain this instruction manual and any order-related information for future reference.



Lift, don't drag!

To avoid damage to product please always LIFT the product when transporting or adjusting the placement.

This product is intended for RESIDENTIAL USE ONLY and not for commercial use.

ASSEMBLY INSTRUCTIONS

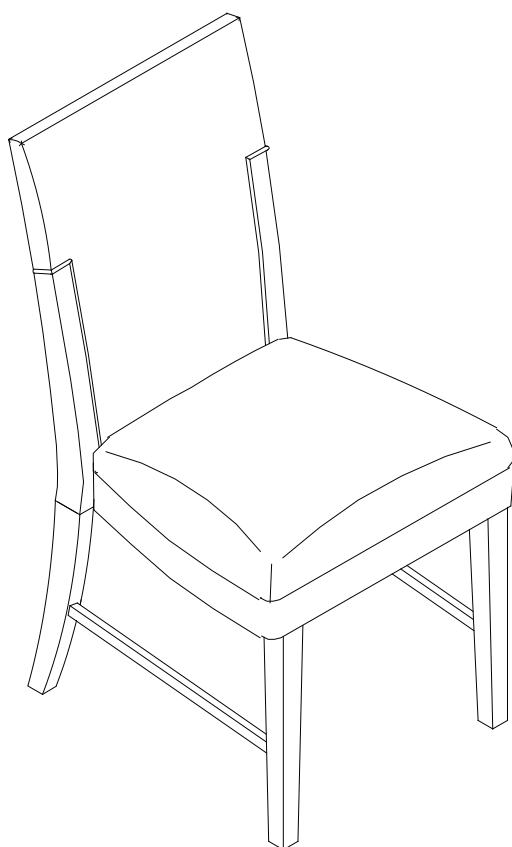

TOOLS REQUIRED



Allen Wrench

(Included)



Phillips
Screwdriver

(Not Included)



2 - People
Recommended

ASSEMBLY RATING



EASY —————> DIFFICULT

The Assembly Rating is a 5-point system showing the level of effort needed to assemble a specific product.



CHECK BEFORE STARTING

Are you missing anything?

Double-check all parts, hardware and accessories listed are all accounted for.

Check out our Quick Tips!

We recommend reviewing the pre-assembly handouts. Even experts need a refresher now and then!

Should we send any replacements?

Are there any irregularities or flaws in the parts? We can send replacements!

Prep Time!

Please review the assembly instructions and all diagrams prior to assembling.

PRE ASSEMBLY INTRODUCTION

We understand building ready-to-assemble furniture can be a challenging experience for some. To help avoid confusion, we have provided some helpful tips that may speed up the process.

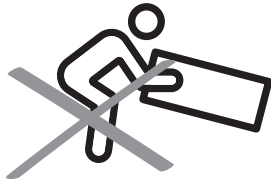

Teamwork

ALWAYS have at least two people to help with transporting and assembling the product to avoid potential injury and/or damage.

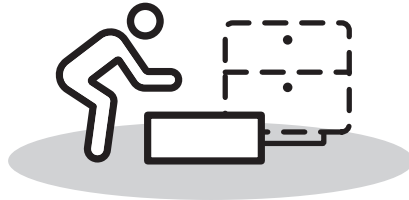
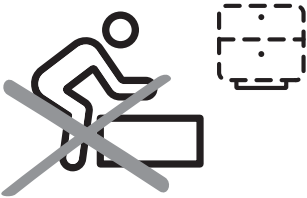

Suitable Location

Assembling near the area of the intended location is highly recommended.



Sufficient Space

Make sure you have enough space to move around during the assembly.



Avoid Scratches

Use cardboard, blankets or a carpeted area while assembling furniture to prevent to prevent scratches and damages.

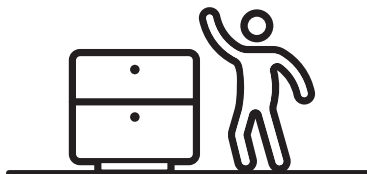
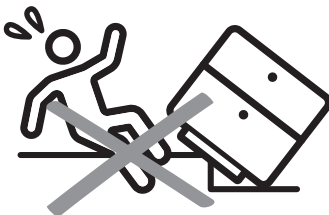

Flat Surface

Make sure the furniture rests on a flat and level surface with each leg evenly touching the floor.

ASSEMBLY AND CARE ADVICE



FAILURE TO FOLLOW THE GUIDELINES BELOW MAY RESULT IN INJURY AND/OR PROPERTY DAMAGE.



Position each part correctly and insert screws or bolts into their respective holes.

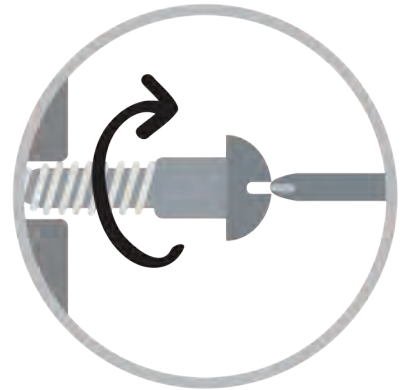

Turn clockwise to tighten and only tighten when step is completed or when instructed to do so.



Use the appropriate hand tools or power tools for assembly. Select steps, such as tightening screws and/or bolts, may require hand tools to avoid causing damage during assembly.



Save the instructions and store any supplied tools for later maintenance.



After two weeks, check and tighten any loose hardware and repeat again every six months thereafter.

IT IS THE USER'S RESPONSIBILITY TO MAINTAIN THE FURNITURE. THE HARDWARE MAY LOOSEN OVER TIME AND MAY CAUSE THE FURNITURE TO BE WOBBLY AND UNABLE TO SUPPORT ITS INTENDED WEIGHT CAPACITY. THIS MAY LEAD TO COLLAPSE AND MAY CAUSE SERIOUS INJURY.

SIDE CHAIR

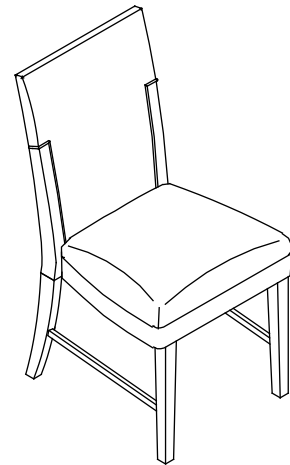
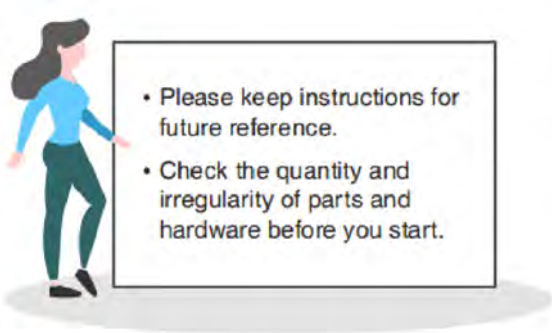

PARTS

#A 1pc

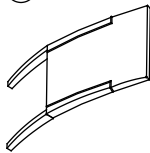

Back Frame

#B 1pc

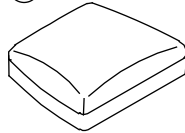

Cushion Seat

#C 2pcs

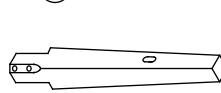

Front Legs (L+R)

#D 2pcs

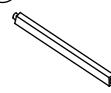

Side Stretcher (L+R)

HARDWARE

#1 2pcs



Bolt Ø 1/4" x 40mm

#2 4pcs



Bolt Ø 1/4" x 50mm

#3 4pcs



Bolt Ø 1/4" x 75mm

#4 10pcs



Spring washer Ø1/4"

#5 10pcs



Flat washer Ø1/4" x19mm

#6 1pc



Allen key 4mm

#7 4pcs



Screw #4x38mm

Exploded View

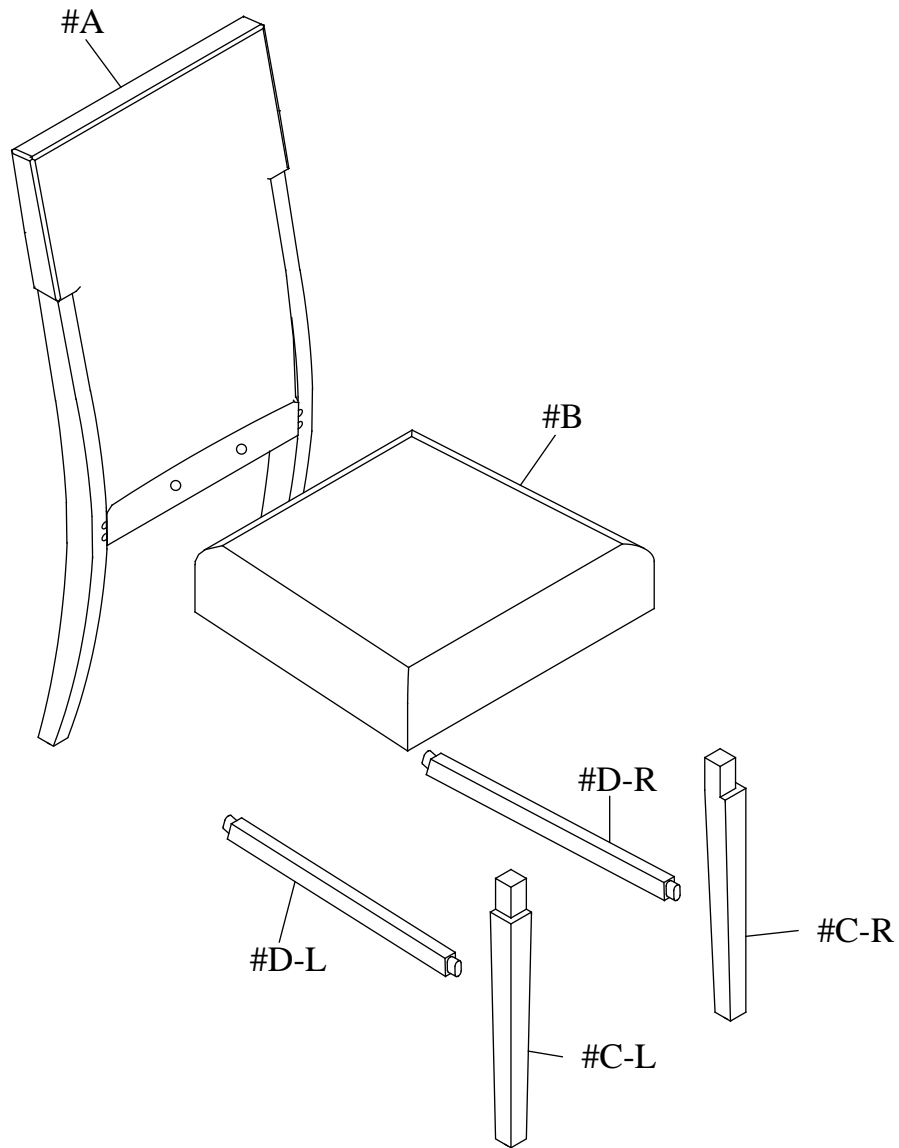

ASSEMBLY INSTRUCTIONS

1

Part #A x1pc

Part #B x1pc

Hardware #1 x2pcs

Hardware #3 x4pcs

Hardware #4 x6pcs

Hardware #5 x6pcs

Align seat frame (#B) to the Back Frame (#A), then secure by using bolts (#1,#3) with washers (#4,#5).

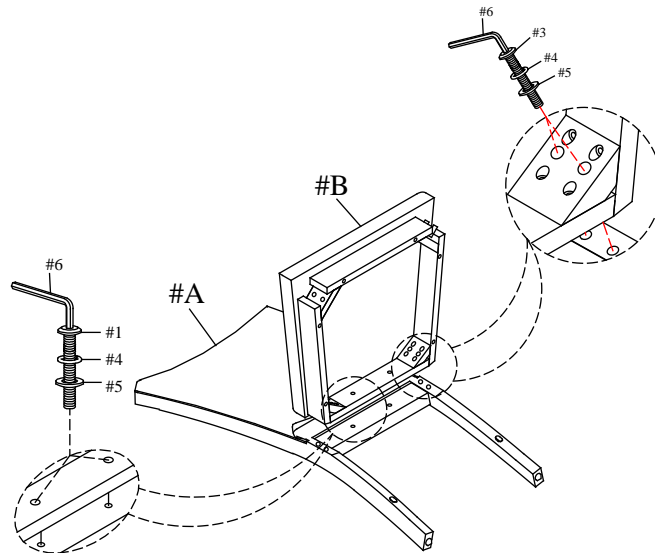

Align legs, seat frame (#C,#B) to the side stretcher (#D,#C,#A), then secure by using screw (#7) bolts (#2) with washers (#4,#5).

2

Part #C-R+L x2pcs

Part #D-R+L x2pcs

Hardware #2 x4pcs

Hardware #4 x4pcs

Hardware #5 x4pcs

Hardware #7 x4pcs

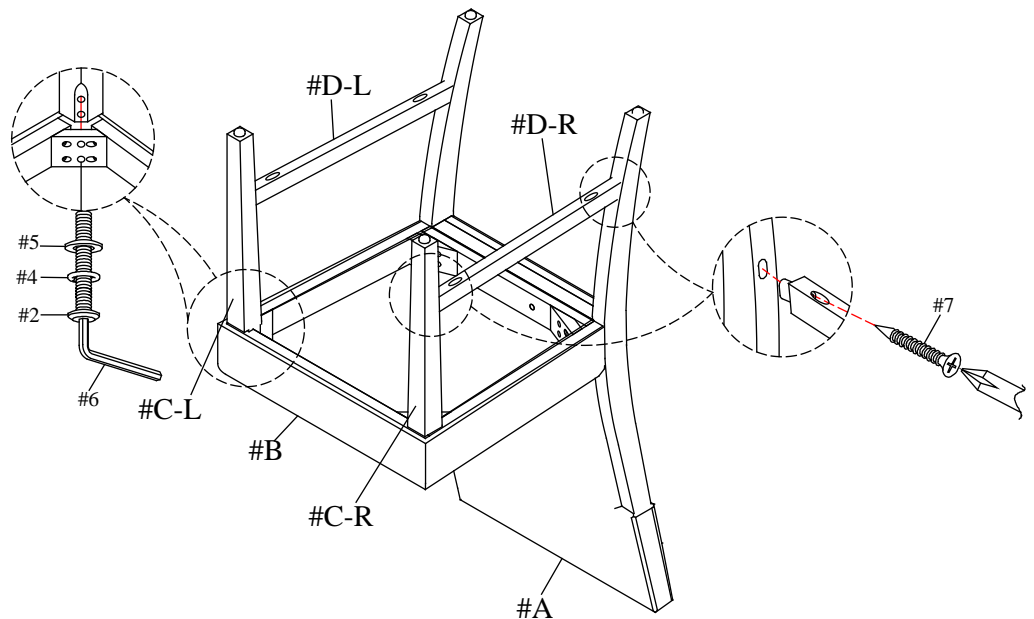

ASSEMBLY INSTRUCTIONS

3

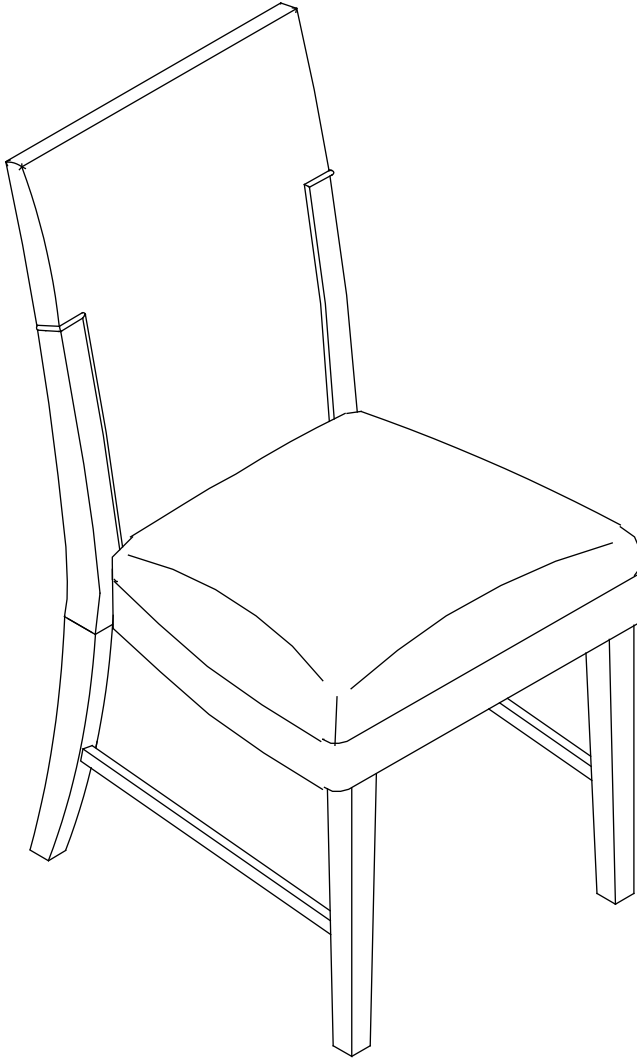

ASSEMBLY COMPLETED



Please ensure the furniture rests on an even and flat surface. If the product wobbles or feels loose, double-check all bolts and/or screws are properly tightened and secured.



Keep this handy!

Please retain this instruction manual and any order-related information for future reference.



Lift, don't drag!

To avoid damage to product please always LIFT the product when transporting or adjusting the placement.

This product is intended for RESIDENTIAL USE ONLY and not for commercial use.