

ASSEMBLY INSTRUCTIONS

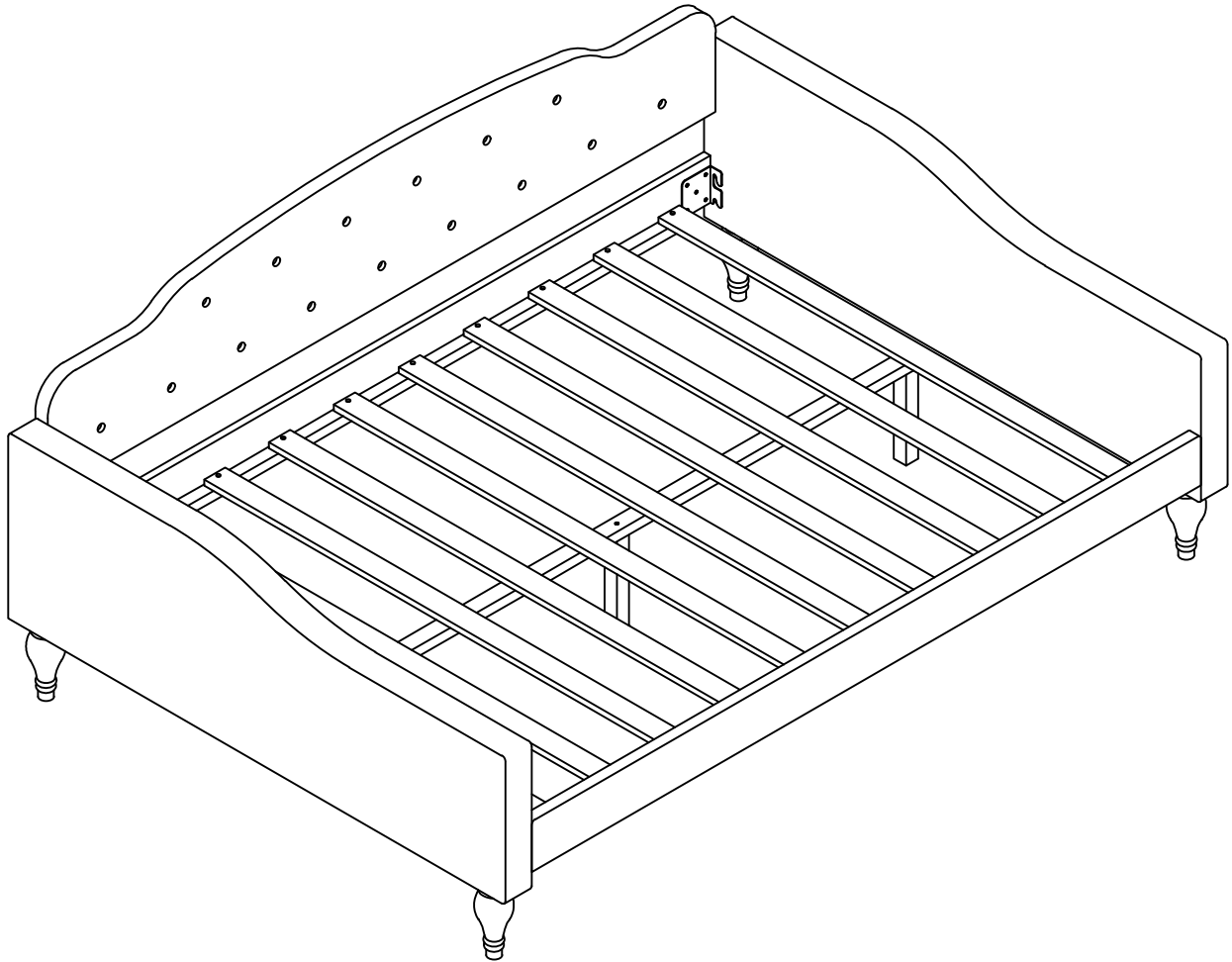

IMPORTANT NOTE

****PLACE ALL PARTS ON A CLEAN AND SMOOTH SURFACE SUCH AS A RUG OR CARPET TO AVOID THE PARTS FROM BEING SCRATCHED**

**** BEFORE YOU BEGIN , KINDY FOLLOW THE ASSEMBLY INSTRUCTIONS STEP BY STEP**

****DO NOT TIGHTEN ALL SCREWS AND BOLTS UNTIL THE BED IS FULLY SET-UP**



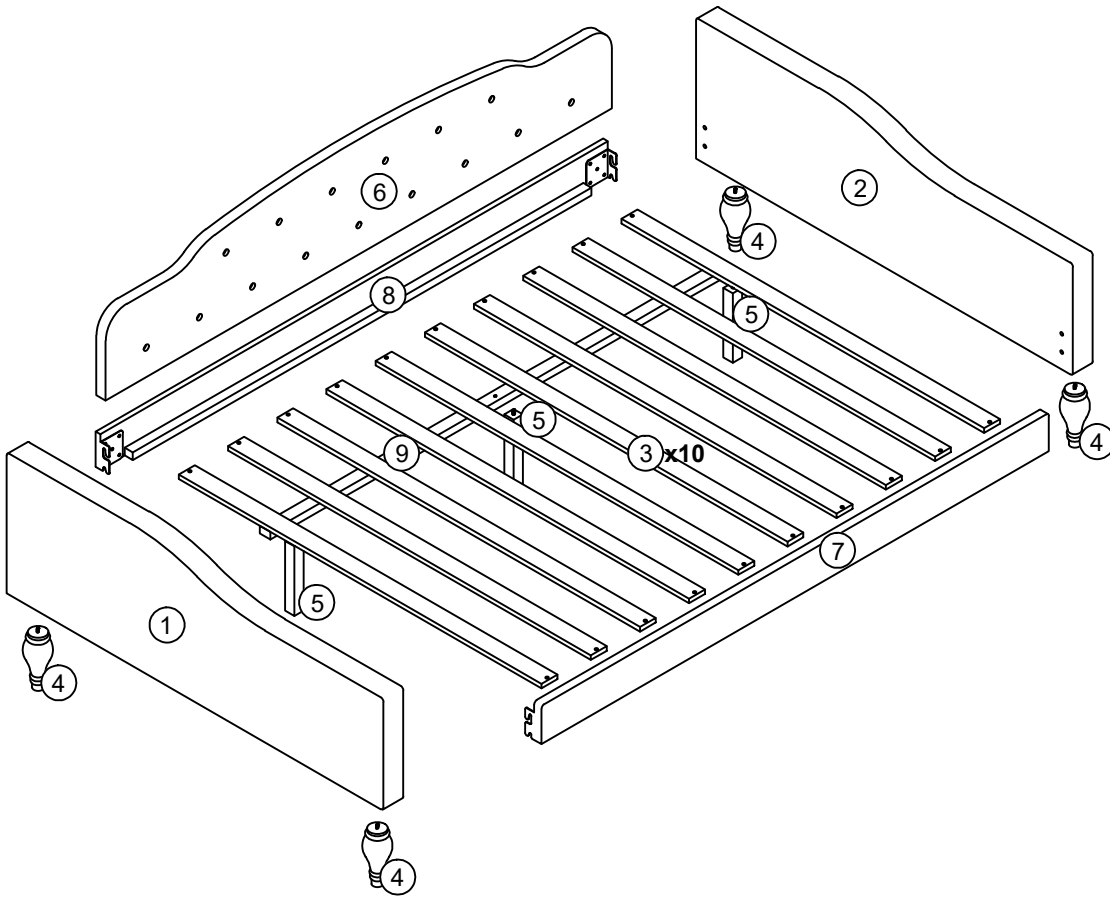

ASSEMBLY INSTRUCTIONS



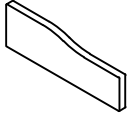
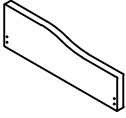

ASSEMBLY INSTRUCTIONS

PARTS IDENTIFICATION

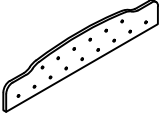

WF 310870(BOX1)

1	Left Arm		1pc	2	Right Arm		1pc
3	Slat Roll (1365x60x15mm)		10pcs	4	Legs		4pcs
5	Support leg		3pcs				

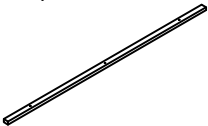
WF 310871(BOX2)

6	Back Panel		1pc	7	Left Upper Rail		1pc
8	Right Upper Rail		1pc	9	Center Rail		1pc

HARDWARE LIST IN WF 310871

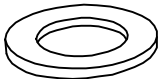
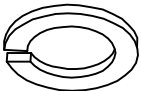
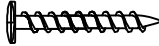
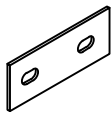
<p>A</p>  <p>Short Bolt (16 pcs) (5/16"X25mm)</p>	<p>B</p>  <p>Allen Wrench (1 pc) (m4x75mm x32mm)</p>	<p>C</p>  <p>Flat Washer (16 pcs)</p>
<p>D</p>  <p>Spring Washer (16 pcs)</p>	<p>E</p>  <p>Flat Head Screw (24 pcs) (m4x30mm)</p>	<p>F</p>  <p>Bracket (4 pcs) (100mmx40mmx2mm)</p>



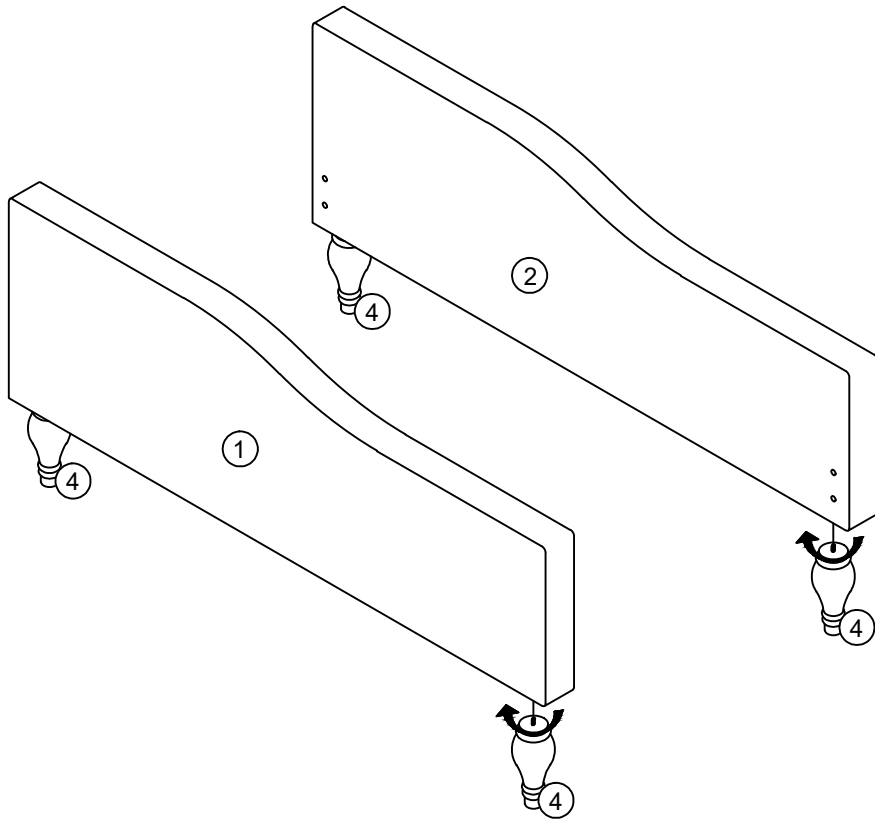

ASSEMBLY INSTRUCTIONS

STEP 1

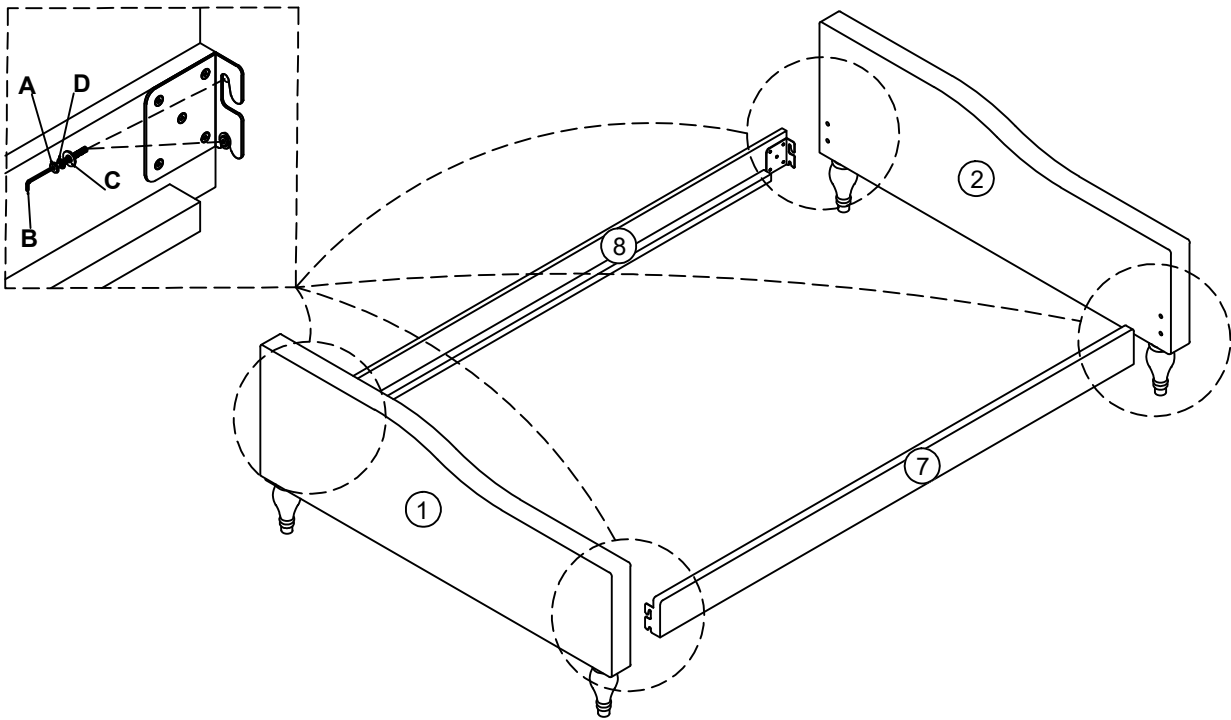

STEP 2





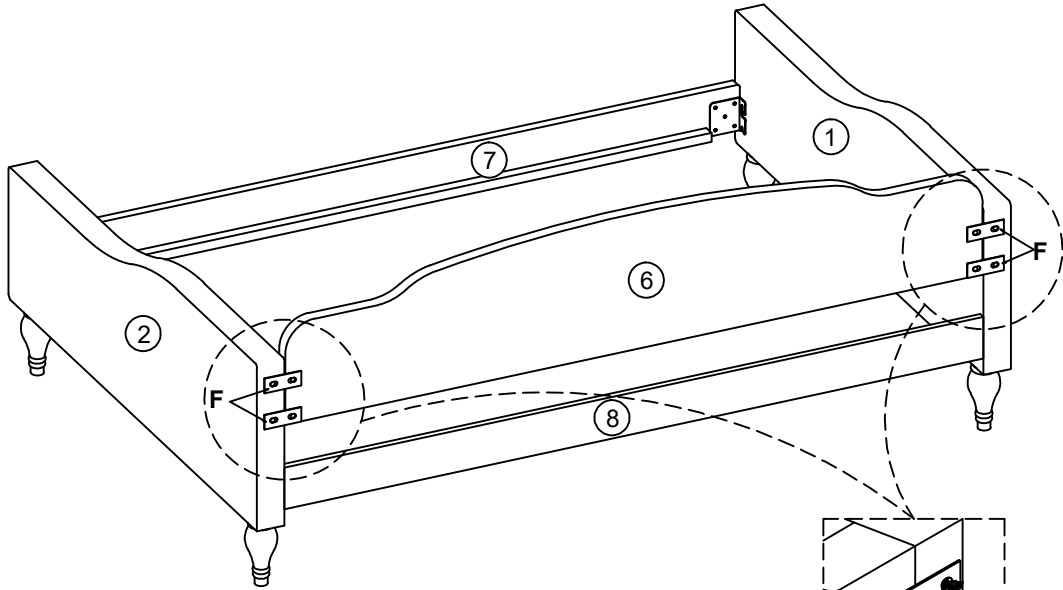

A	Bolt (5/16" x 25mm)		8pcs	D	Spring Washer		8pcs
B	Allen Wrench (M5x75mm x32mm)		1pc	C	Flat Washer		8pcs

ASSEMBLY INSTRUCTIONS

STEP 3



F	Bracket (100mmx40mmx2mm)		4pcs				
A	Bolt (5/16" x 25mm)		8pcs	D	Spring Washer		8pcs
B	Allen Wrench (M5x75mm x32mm)		1pc	C	Flat Washer		8pcs

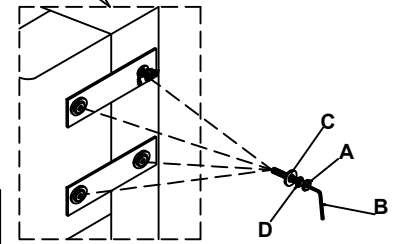

STEP 4

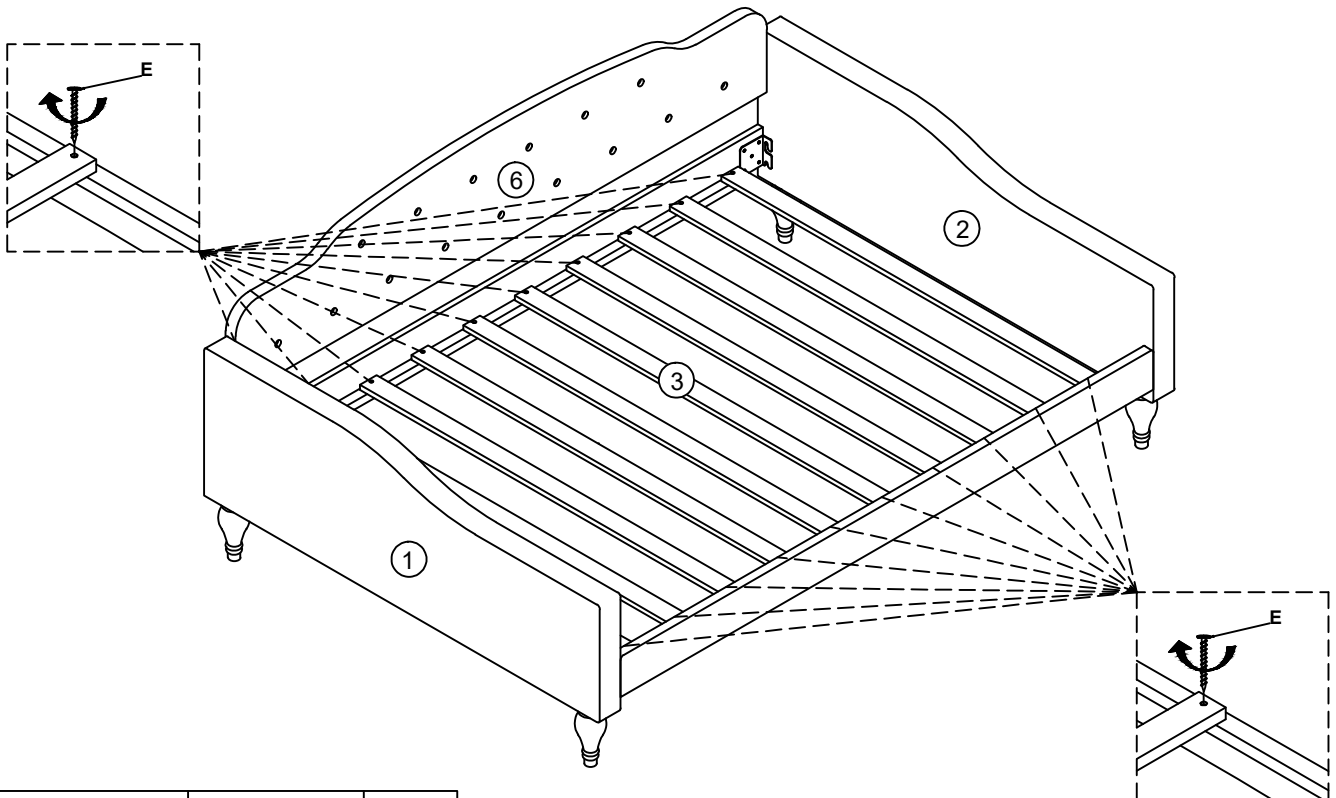

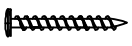
E	Flat Head Screw (m4x30mm)		20pcs
---	-------------------------------------	---	-------

ASSEMBLY INSTRUCTIONS

STEP 5

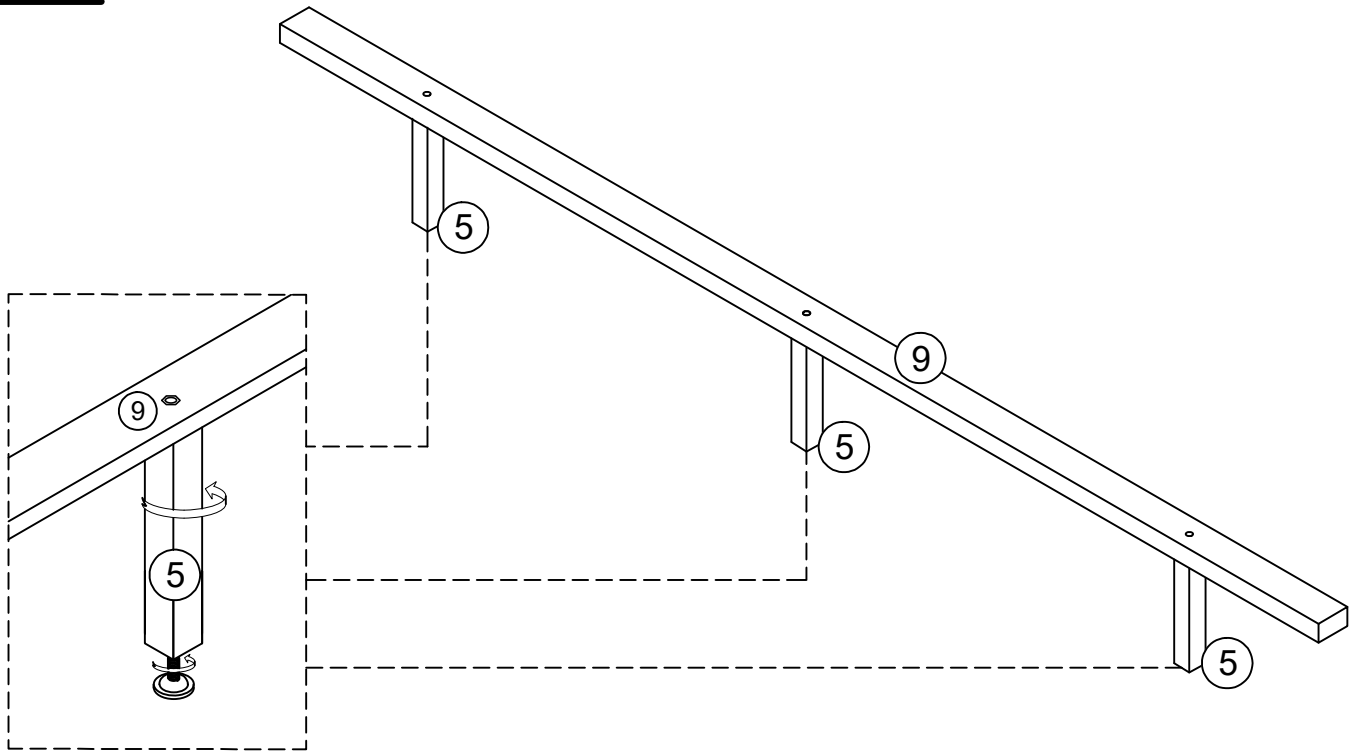

STEP 6

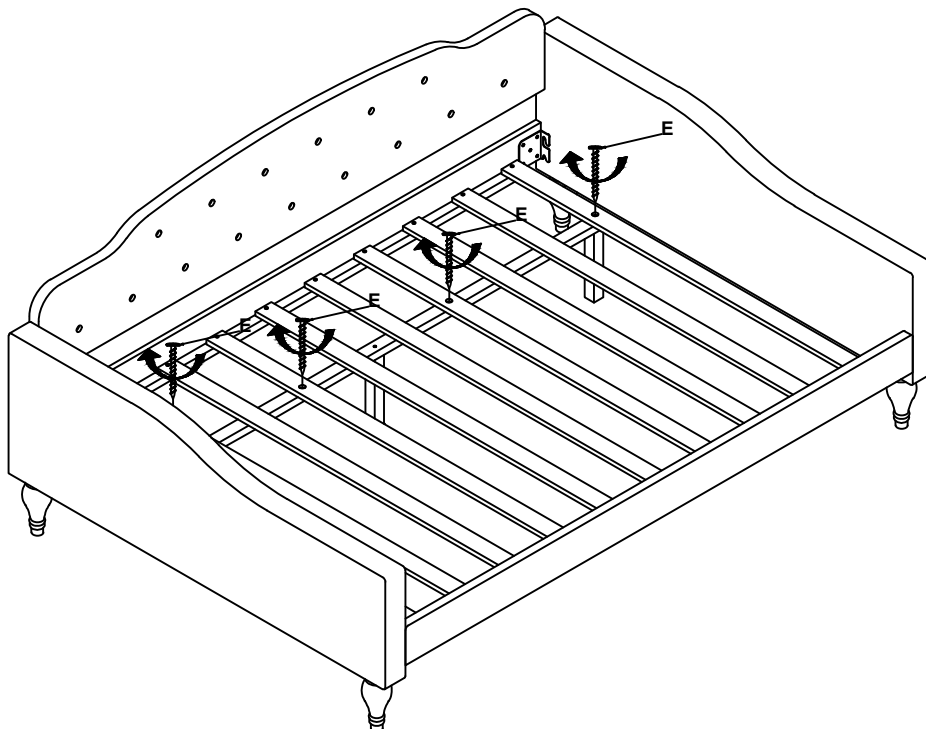

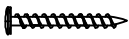
E	Flat Head Screw (m4x30mm)		4pcs
---	------------------------------	---	------

ASSEMBLY INSTRUCTIONS

STEP 7
COMPLETE

