

WARNING!!

Children have died from furniture tipover. Tip restraints have been included with this product; you must install the tip restraints according to these instructions in order to minimize the risk of furniture tipping.

NEVER allow children to climb or hang on furniture, including drawers or cabinet doors.

In addition to installing the restrains, to help prevent tip-over

1. **NEVER** put a TV or other heavy objects on top of this product".
2. Do not stand on the product

⚠ WARNING	
	<p>Children have died from furniture tipover. To reduce the risk of furniture tipover:</p> <ul style="list-style-type: none">• ALWAYS install tipover restraint provided.• NEVER put a TV on this product.• NEVER allow children to stand, climb or hang on drawers, doors, or shelves.• NEVER open more than one drawer at a time.• Place heaviest items in the lowest drawers.• Do not defeat or remove the drawer interlock system.
	<p><i>This is a permanent label. Do not remove!</i></p>

Assembly Instructions



Caution : You must read this before you proceed



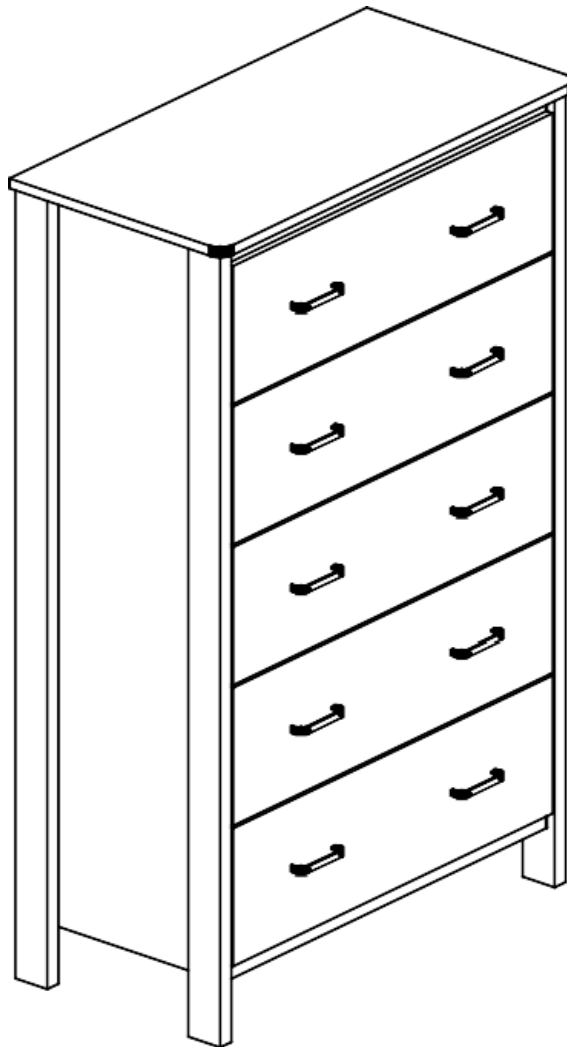

Sets often ship in multiple boxes and may arrive a day or two apart.

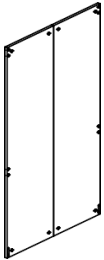
5 Drawer Chest

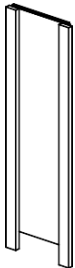
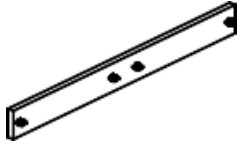
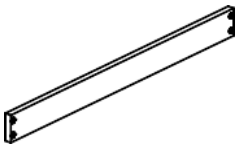
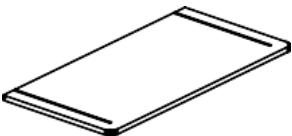
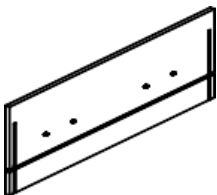

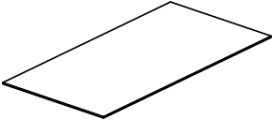
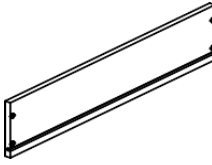

Parts List

Label	Picture	Description	QTY
A		Back Panel	2
B		Side Panel (R)	1
C		Side Panel (L)	1
D		Back Apron	2
E		Front Apron	3
F		Top Panel	1
G		Drawer Front	5

H		Drawer Side (R)	5
I		Drawer Side (L)	5
J		Drawer Base	5
K		Drawer Back	5
L		Handle	10

Hardware

Label	Picture	Description	QTY
①		Anti Tipping	2 Sets
②		Bolt (M4x16mm)	21 Pcs

Assembly Preparation

Before
Beginning
Assembly:

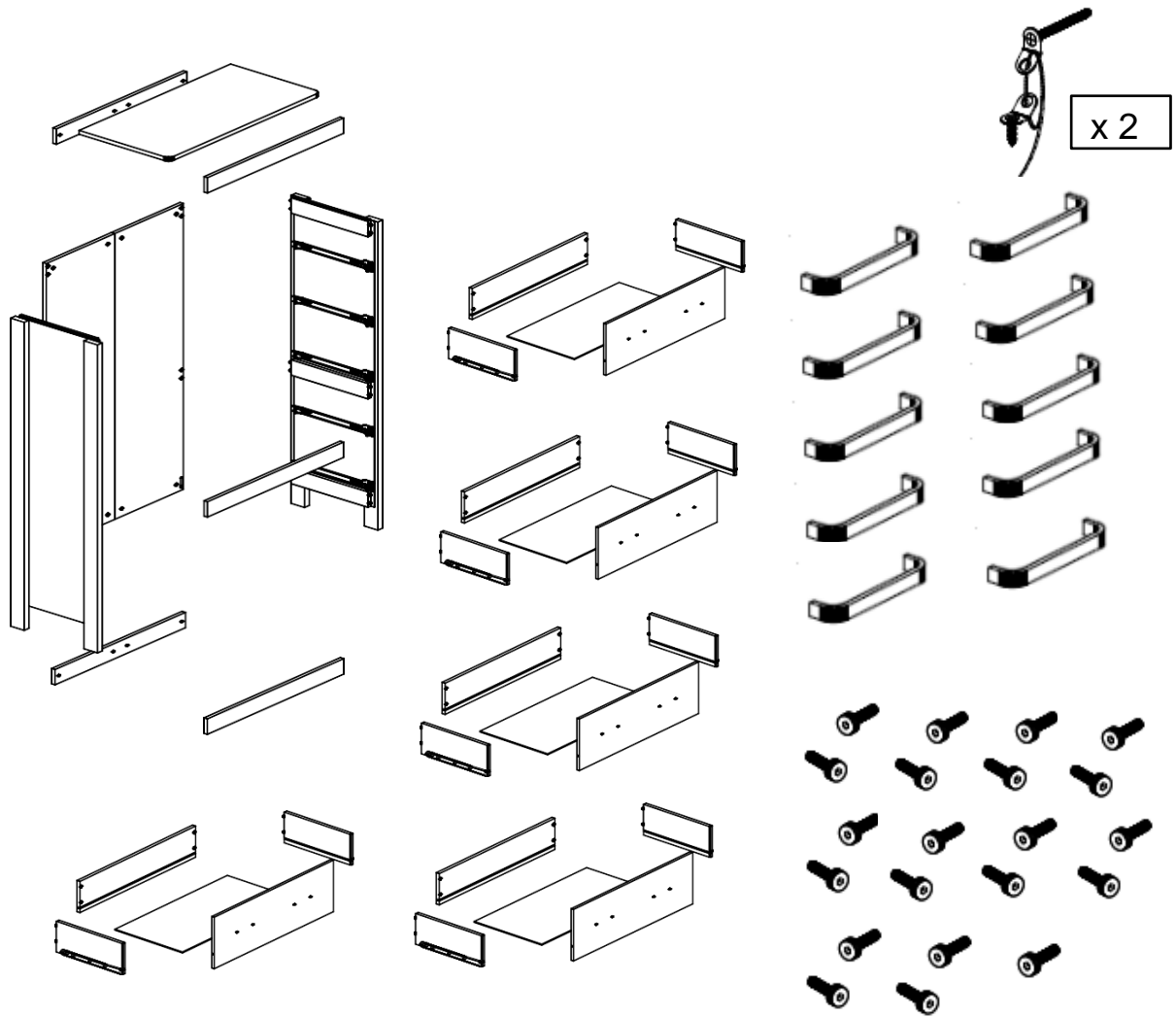

- Read instructions, cover to cover-

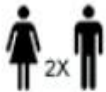

- Have 2 adults on hand for assembly-



- Do not assemble on flooring or carpet-



- Assemble on a clean non-marring surface (packing foam)-



- Save all packaging until finished-

Assembly Steps

Overview

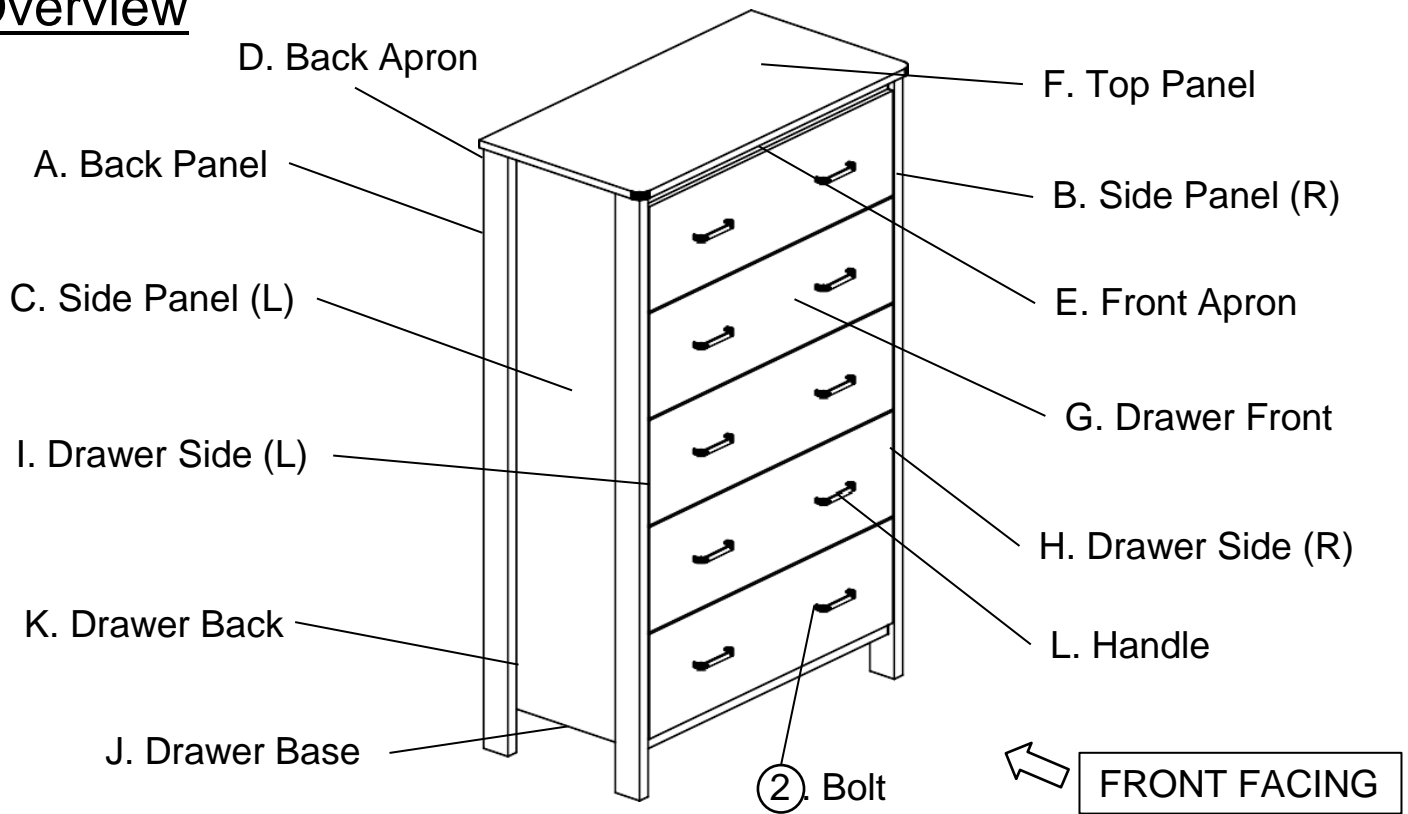

This 5 Drawer Chest has multiple parts and may require up to 30 minutes to assemble. To give an overview on the 5 Drawers Chest parts, the above picture is to help you put the various parts into perspective. Please read through the instructions below to familiarise yourself with the parts and steps before assembly.

Step 1

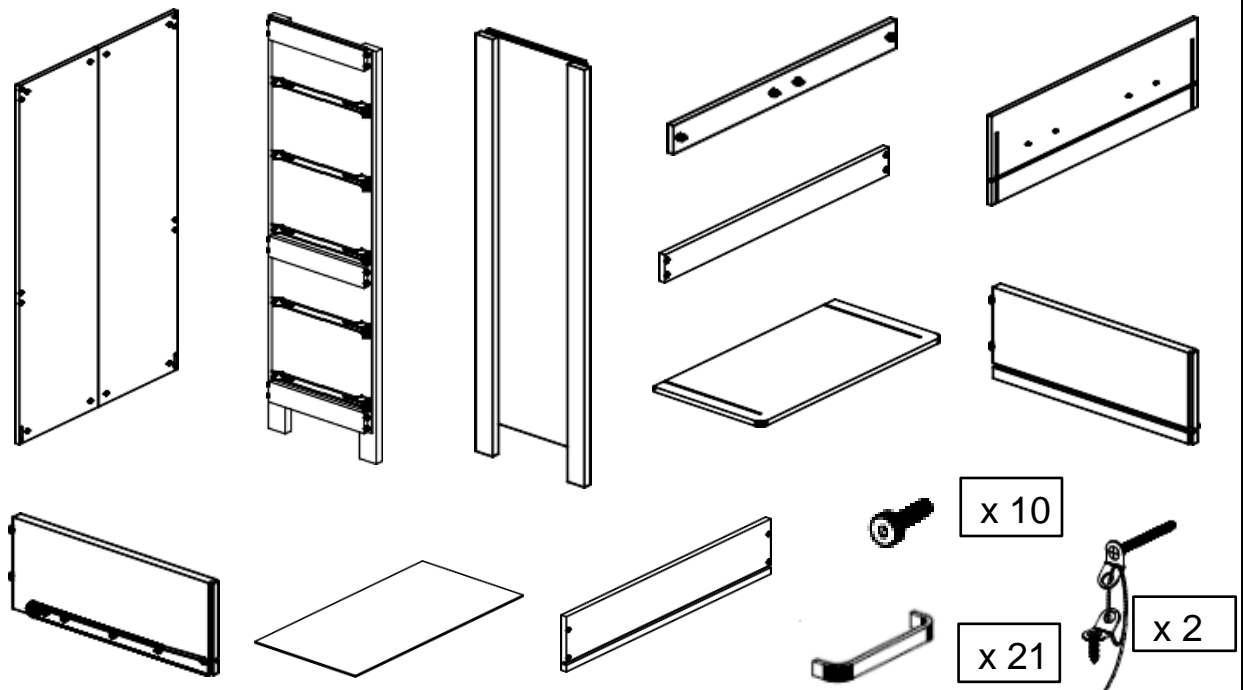

Unpack and place all parts on a clean, non-marring surface. Before starting the assembly work, make sure the surface is clean and soft to avoid any scratches or damage.

Step 2

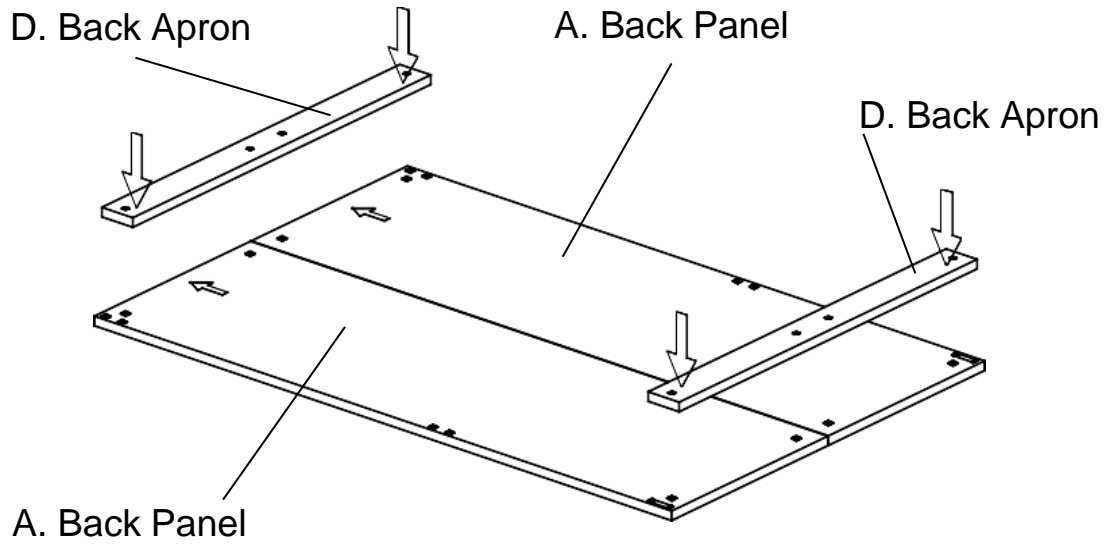

Place the A. Back Panels side by side, then align the D. Back Apron directly to the mounting position as the picture shown

Step 3

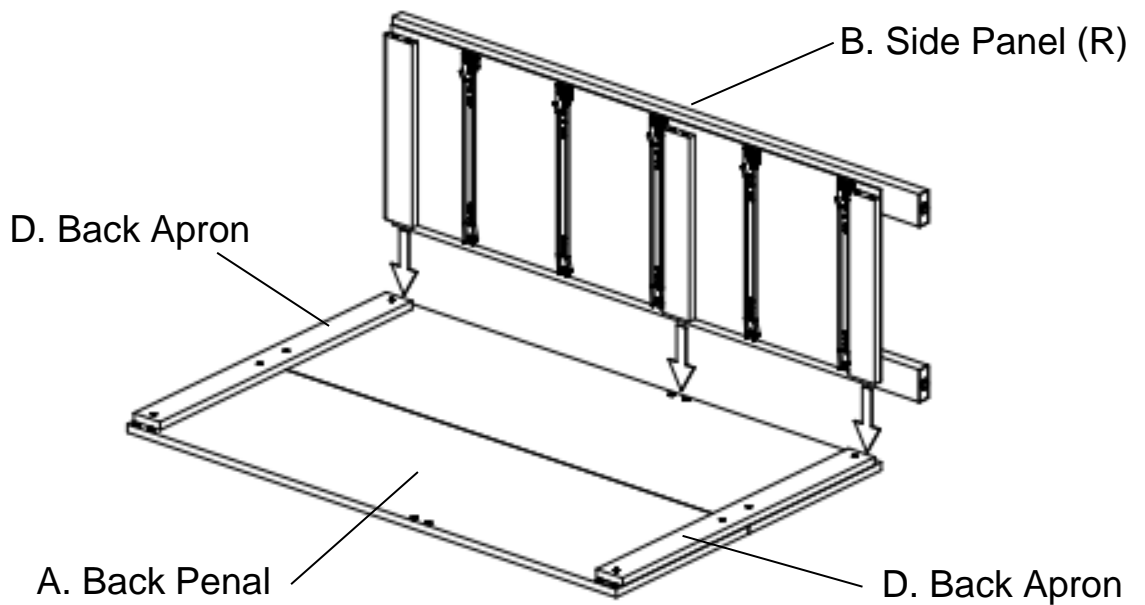

Then insert the B. Side Panel (R) directly into the mounting position.

Step 4

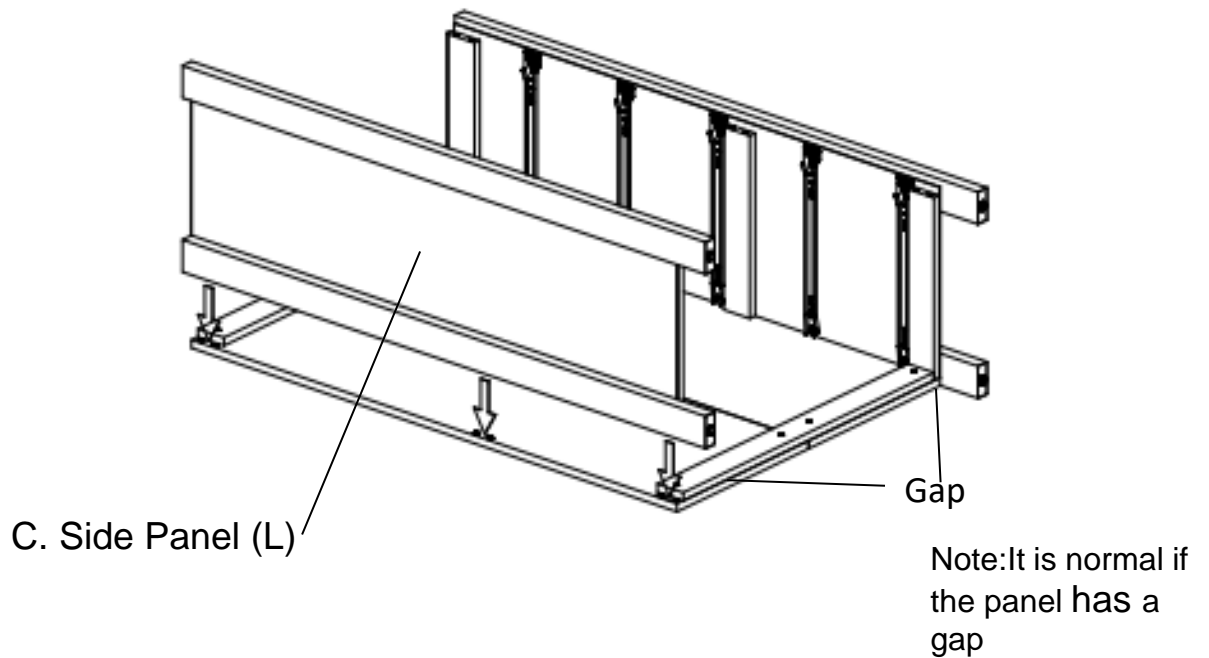

Repeat step 3 for the C. Side Panel (L) as shown. Align the compress fit locking dowels with the corresponding receptor holes, then push them firmly into final locked position, please note once locked, these will not come back apart without potential damage

Step 5

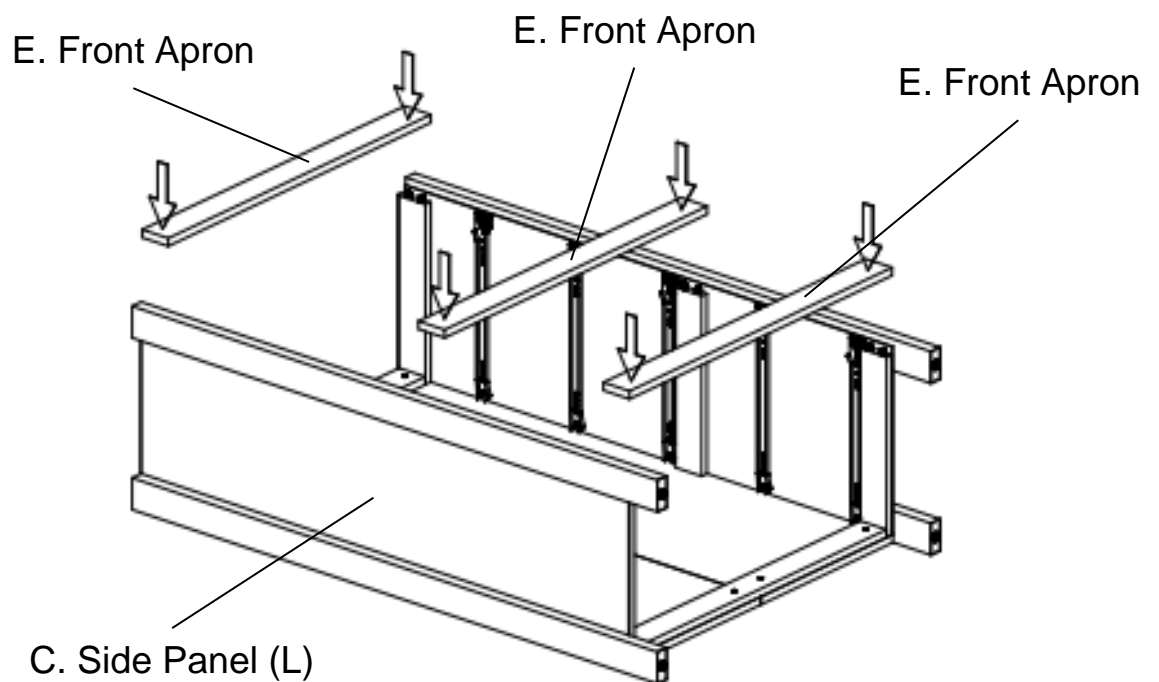

Put the parts E. Front Apron into the correct position and push them firmly into final locked position as shown.

Step 6

Note:
Gently slide
the panel F
down into
place.

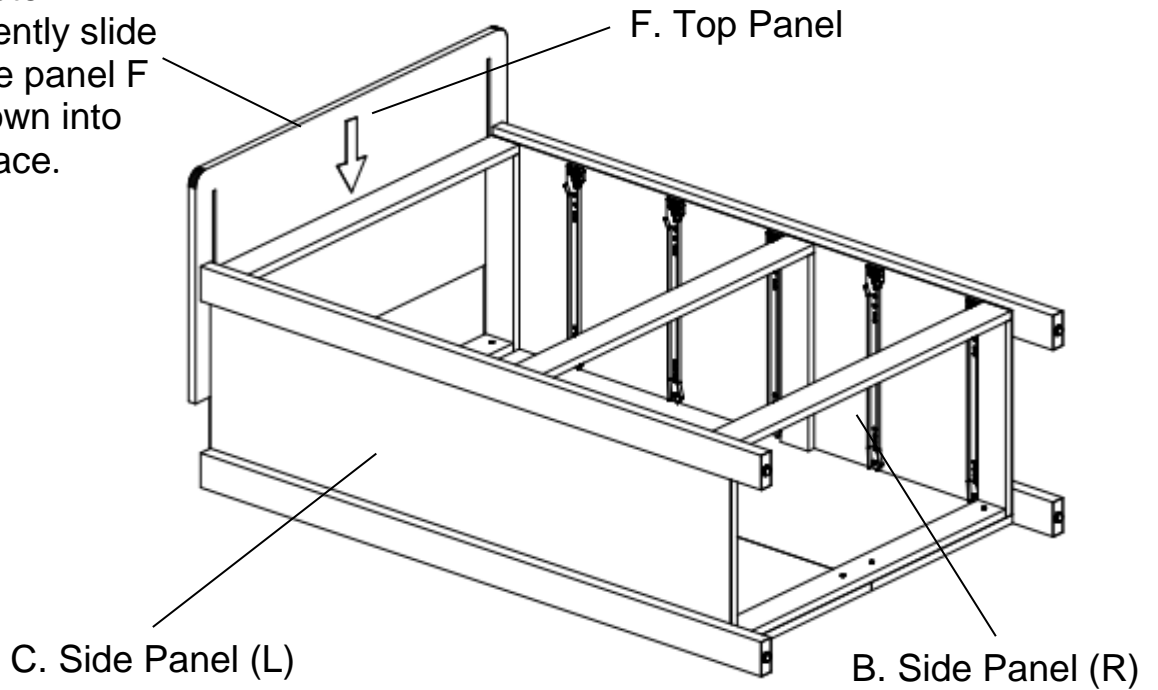

Align the dovetails on parts F. Top Panel with the grooves on B. Side Panel (R) and C. Side Panel (L), then gently slide the F. Top Panel into position.

Step 7

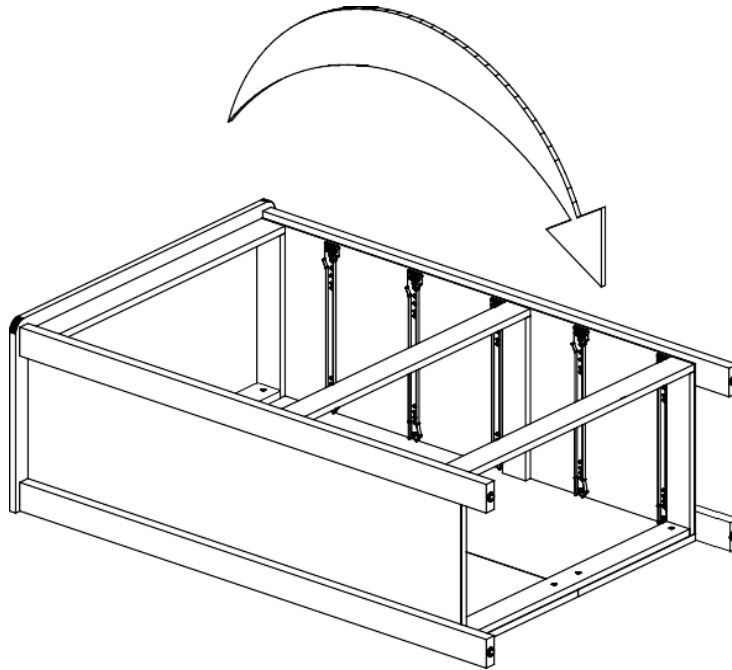

Rotate the cabinet 90° carefully in an upright position, the Top Panel should be on the top.

Step 8

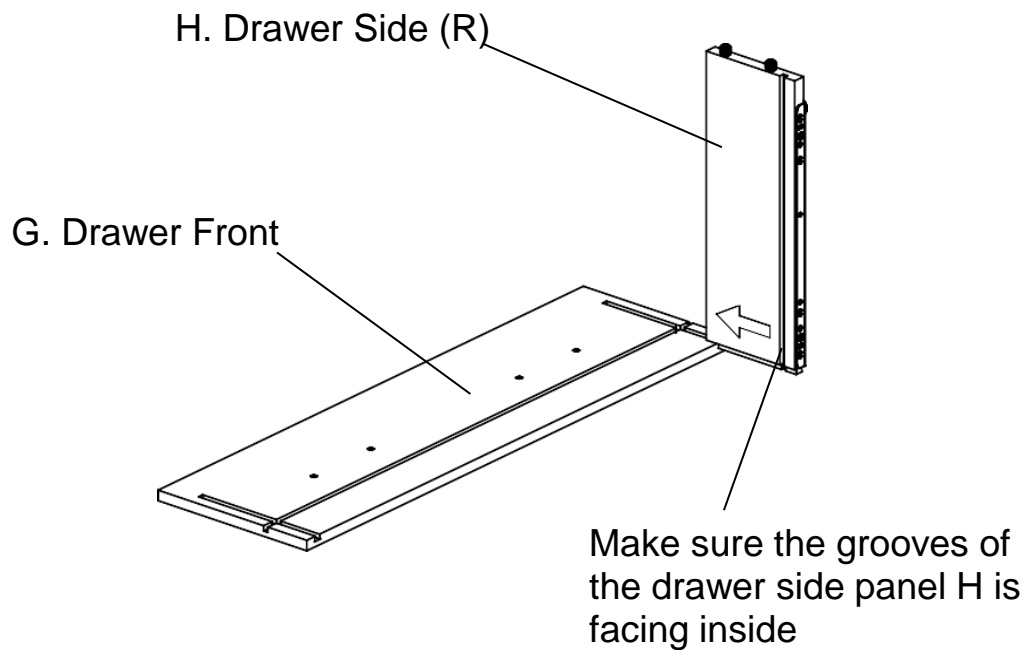

Align the dovetails on parts H. Drawer Side (R) with the grooves on part G. Drawer Front then gently slide them into position

Step 9

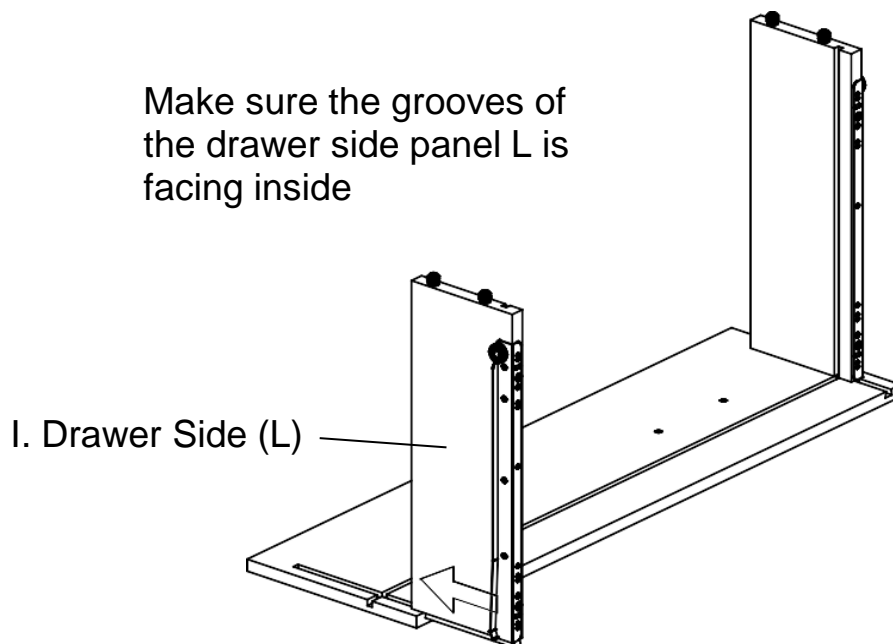

Repeat step 8 as shown to slide in I. Drawer Side (L).

Step 10

J. Drawer Base

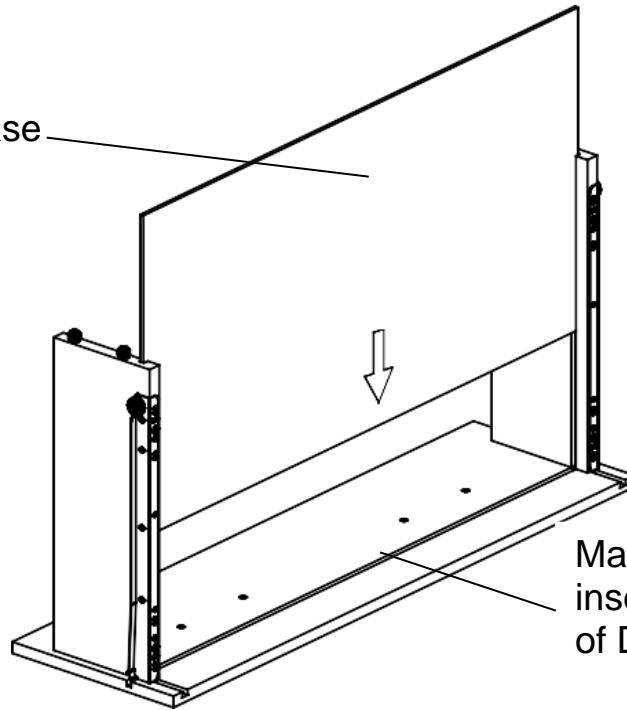

Make Sure the Part J
insert into the grooves
of Drawer Front

Ensure the grooves in the drawer sides and the drawer front are properly positioned as shown above, then slide panel J. Drawer Base into place

Step 11

K. Drawer Back

Make sure the
part K is insert
to the grooves
of Drawer Front

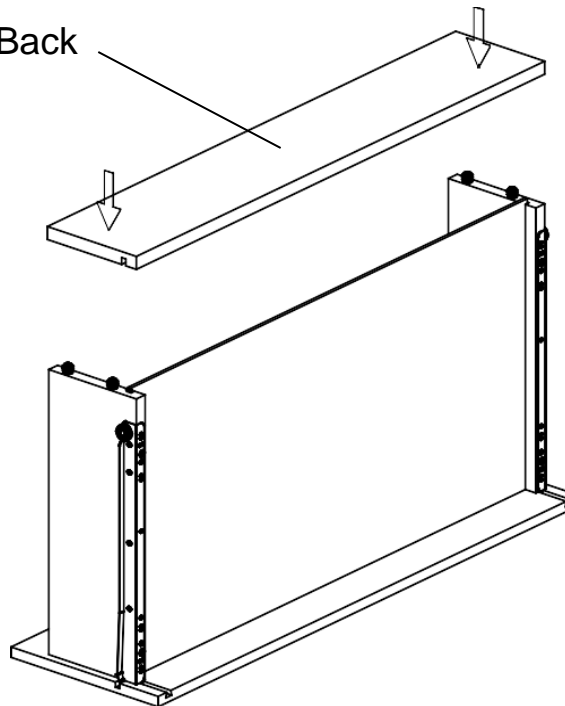

Align the back
panel groove on
panel K with the
back panel, then
press firmly on all
4 corners and
compress fit panel
J to panels H and
I.

Follow the same compress fit locking style for the panel K as in step 5, as shown. Ensure the Panel K.Drawer Back is fit into the final locked position.

Step 12

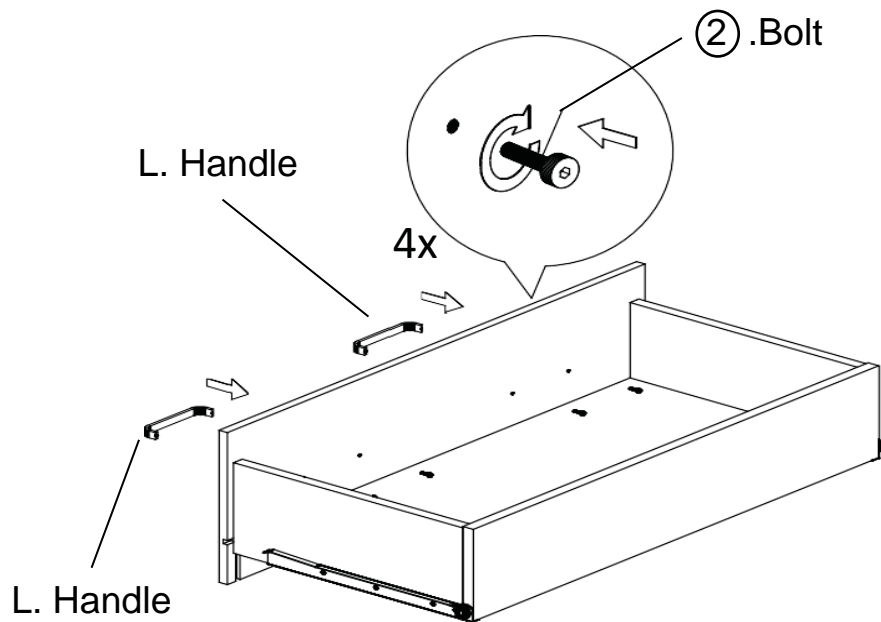

Using the hand, tighten the Bolt ② with the L. Handle until tightened as shown. Repeat Step 8 to Step 12 respectively for the remaining 4 drawers. Set up the remaining 4 drawers in order.

Step 13

The sticker marking is for Anti Tipping Braket (b) position (Estimate 2" below the top panel)

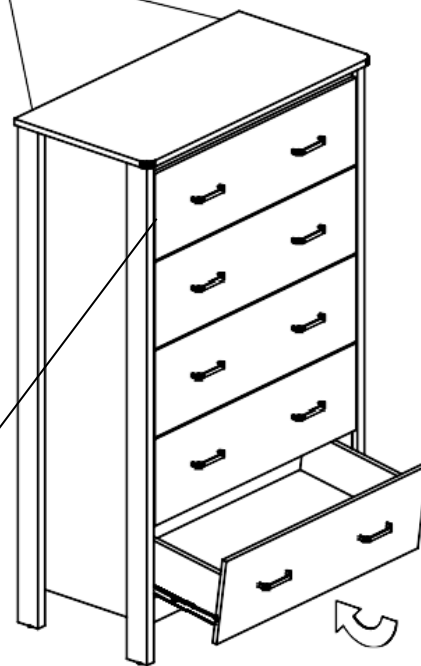
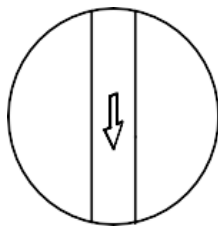

* The drawer with the warning label sticker is only put on the top

Tilt the completed drawer slightly to align the rail wheels with the fixed side rails, then slide them into place and your finished 5 Drawers Chest is ready to use!

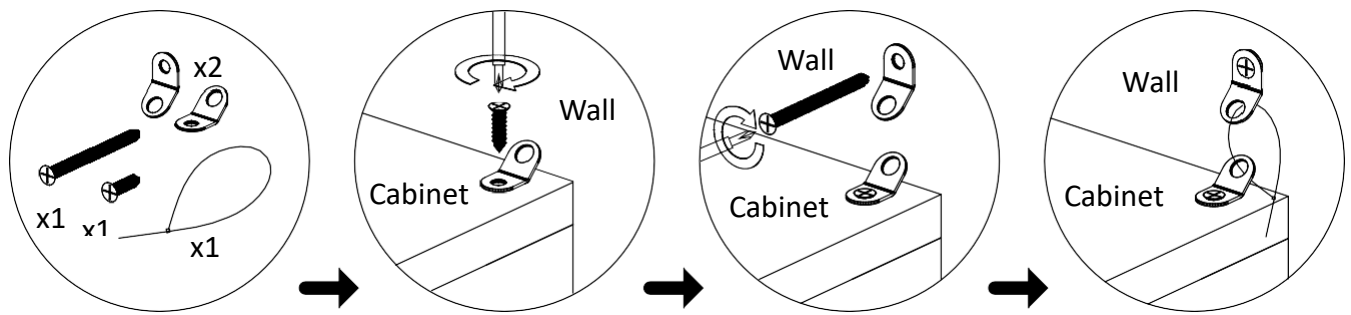

Installation Instruction:

This tip restraint must be attached to a wall stud using the 2" screw enclosed.

1. Attach a bracket securely to the back top rail of the furniture using the 5/8" screw provided, through the smaller hole.
2. Locate the other bracket on the wall over a wall stud and 2 inches below the mounting bracket secured to the back of your unit. Attach to the wall stud using the 2" screw provided, though the smaller hole.
3. Place the furniture into position so both mounting brackets are vertically in line.
4. Lace the end of the restraint strap through the larger hole in each mounting bracket. Bring both ends together and slide the flat end through the locking end and draw it through until all slack is removed.
5. Confirm that the strap is securely laced and locked.

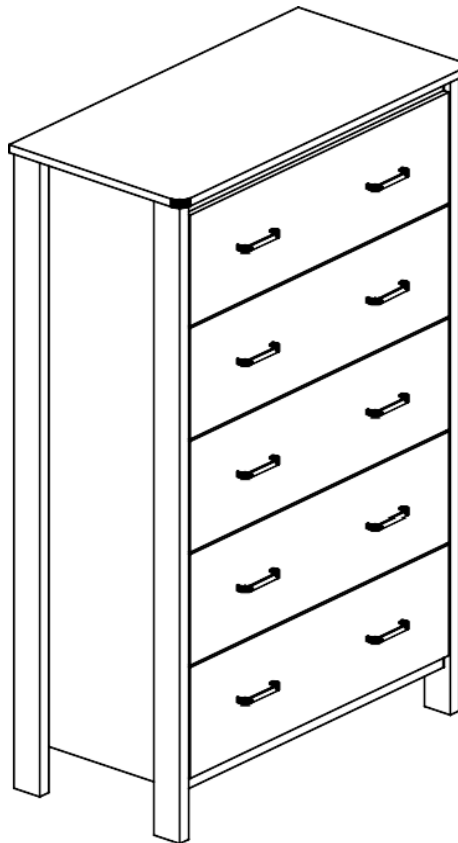

Your 5 Drawer Chest is ready for use.
 5 Drawer Chest should only be used on a flat, level surface.

This

Care & Maintenance



- Furniture may scratch floor. We recommend using furniture pads to protect your floors



- Do not put hot items directly on furniture surface.



- Do not clean furniture with harsh cleansers or polish.



- Do not place furniture under direct sunlight.



- Do not place furniture near heating or cooling vents.



- Do not write on furniture without a padded barrier to protect the surface.



- Do not place furniture outside . For indoor use only.



- Not for commercial use. For residential use only.



- Stains may be removed with mild soap solution and damp cloth.



- Children should not climb or jump on the furniture.



- Dust and pick-up spills using a clean, non-colored, lint-free cloth.

Questions & Answers about Proposition 65

- What is Proposition 65?

Proposition 65 requires businesses to provide warnings to Californians about significant exposures to chemicals that cause cancer, birth defects or other reproductive harm. These chemicals can be in the products that Californians purchase, in their homes or workplaces, or that are released into the environment. By requiring that this information be provided, Proposition 65 enables Californians to make informed decisions about their exposures to these chemicals.

Proposition 65 also prohibits California businesses from knowingly discharging significant amounts of listed chemicals into sources of drinking water.

Proposition 65 requires California to publish a list of chemicals known to cause cancer, birth defects or other reproductive harm. This list, which must be updated at least once a year, has grown to include approximately 900 chemicals since it was first published in 1987.

- What types of chemicals are on the Proposition 65 list?

The list contains a wide range of naturally occurring and synthetic chemicals that include additives or ingredients in pesticides, common household products, food, drugs, dyes, or solvents. Listed chemicals may also be used in manufacturing and construction, or they may be byproducts of chemical processes, such as motor vehicle exhaust.

- What does a warning mean?

If a warning is placed on a product label or posted or distributed at a workplace, a business, or in rental housing, the business issuing the warning is aware or believes that it is exposing individuals to one or more listed chemicals.

By law, a warning must be given for listed chemicals unless the exposure is low enough to pose no significant risk of cancer or is significantly below levels observed to cause birth defects or other reproductive harm.

- Where can I get more information on Proposition 65?

If you have specific questions on the administration or implementation of Proposition 65, you can contact OEHHA's Proposition 65 program at P65.Questions@oehha.ca.gov, or by phone at (916) 445-6900.