

CARE AND MAINTENANCE

THE SURFACE OF THE BLOCK SHOULD BE TREATED BEFORE USE WHEN NEW AND PERIODICALLY THEREAFTER WITH A "FOOD GRADE" MINERAL OIL (BLOCK OIL) TO HELP PREVENT BACTERIAL PENETRATION AND TO ALLOW FOR EASY CLEAN UP.

DO NOT ALLOW MOISTURE OF ANY KIND TO STAND ON WOOD SURFACE FOR LONG PERIODS OF TIME.

BUTCHER BLOCK SURFACE SHOULD BE THOROUGHLY CLEANED AFTER EACH USE WITH A WELL WRUNG, MOIST SOAPY TOWEL, CLOTH, OR ANTIBACTERIAL WIPE. AVOID THE USE OF HARSH CHEMICALS OR ABRASIVE MATERIALS TO CLEAN THE SURFACE OF THE BUTCHER BLOCK AS THESE MAY HARM THE NATURAL WOOD SURFACE.

BE SURE THAT THE WOOD SURFACE IS DRIED COMPLETELY AFTER USE AND / OR CLEANING TO PREVENT WARPING, CRACKING, AND SEPARATION

Complete the look!



SPEEDRACK



PAPER TOWEL HOLDER



KNIFE HOLDER



TOWEL BAR & "S" HOOK

ASSEMBLY INSTRUCTION

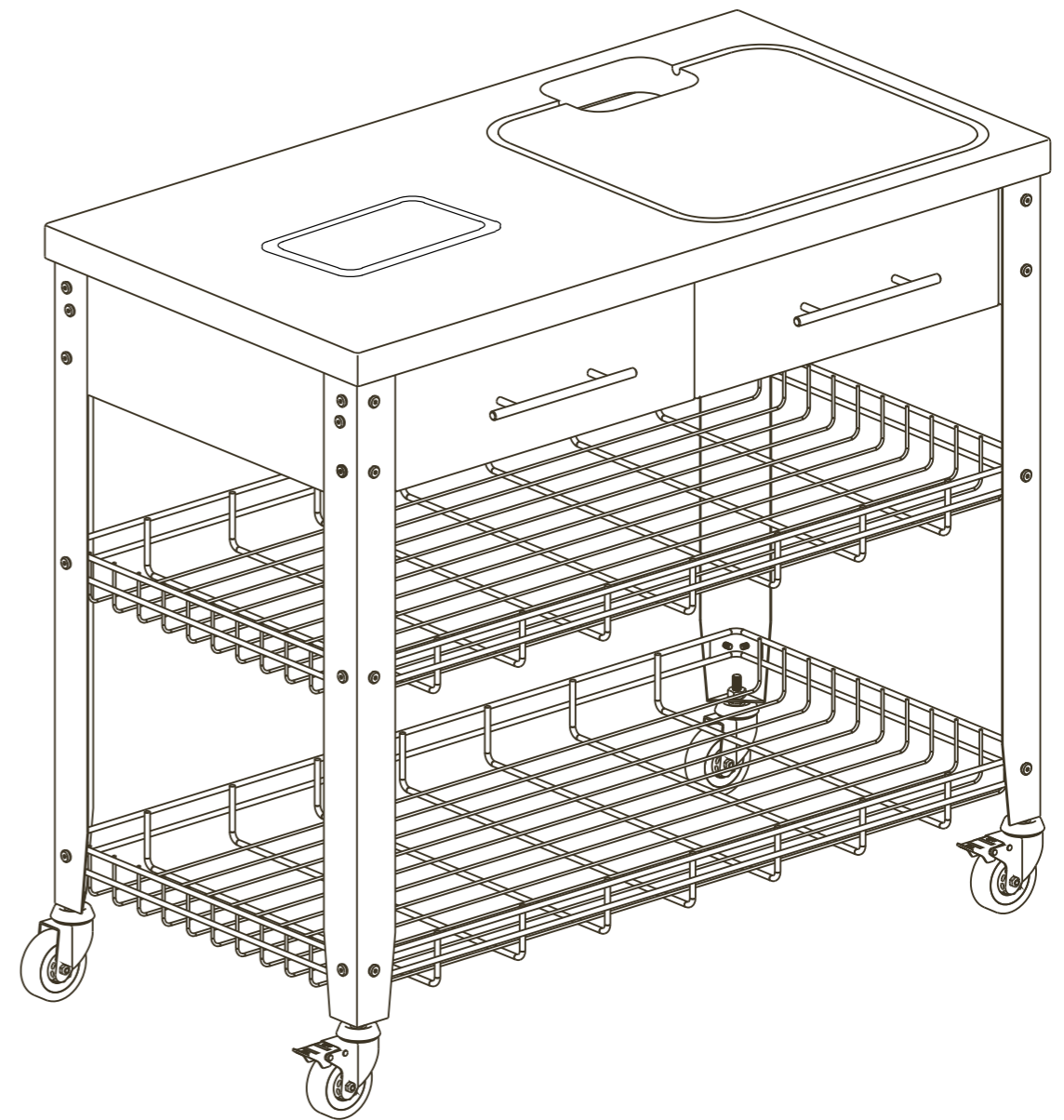

STEP 3.

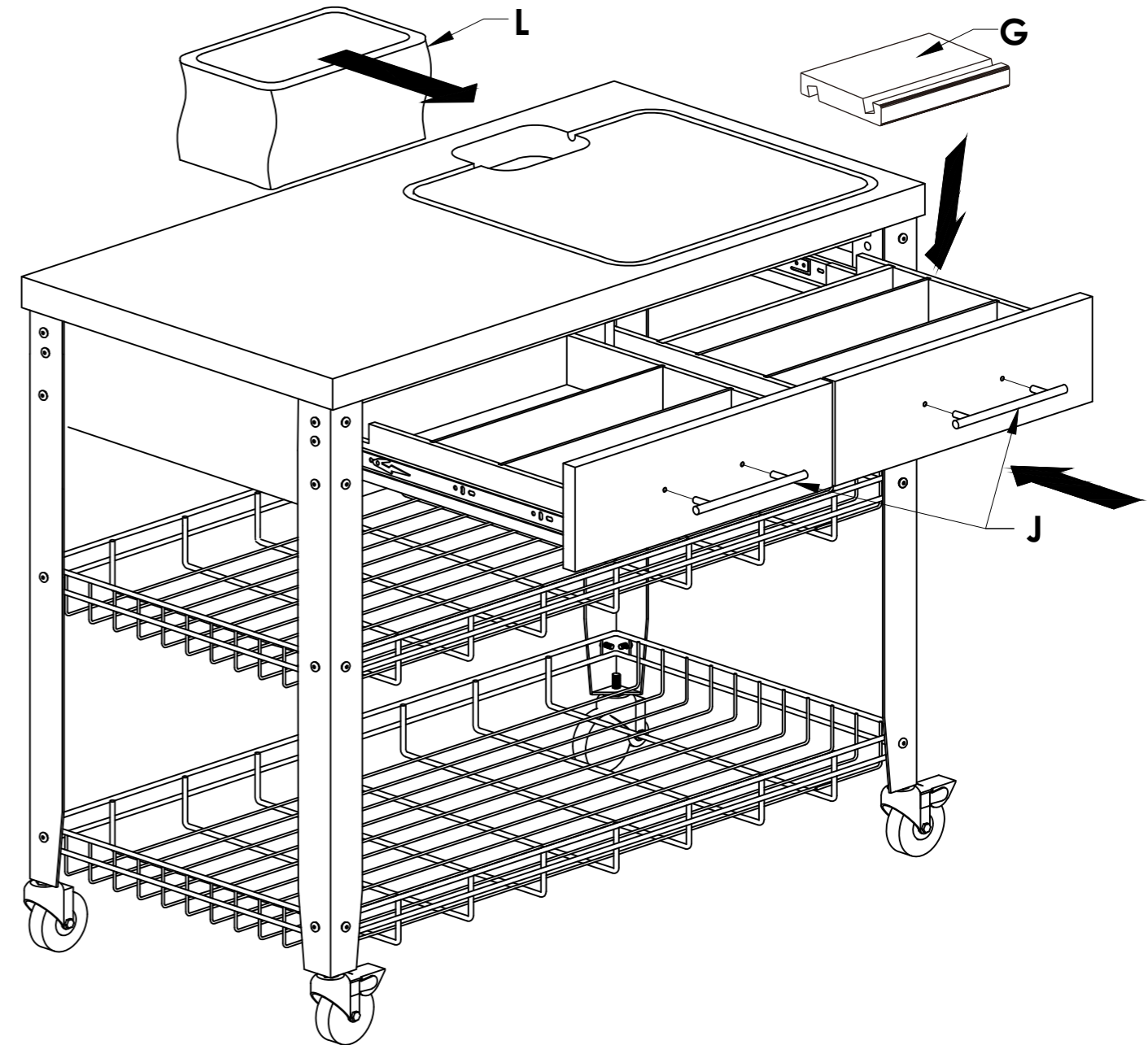

ASSEMBLY TIPS: STADIUM SERIES WORK STATION™

TOOLS NEEDED: PHILLIPS HEAD SCREWDRIVER

Unpack all parts carefully.

Cover work surface with soft blanket or similar substance so as not to damage the unit or your work surface.

Step 1

- Lay top panel Assembly (C) upside down on stable surface.
- Install leg frames (B) to the top assembly (C) using short bolts (N) and allen Key (RM) NOTE: The side of the each leg that has the additional hole must be lined up with holes on each end of the cart. These holes are for the installation of the towel bar. Do not tighten at this time. Leave approximately 1/8 inch exposed thread pattern so the shelves can be installed.
- Install the 2 brake wheels (BW) using wheel wrench (Q) to the front side of the cart.
- Install 2 wheels (B) to the back side of the cart using wheel wrench (Q).
- NOTE: bolts (U) and 2 nuts (XA) are cosmetic only and will be used on Step 2.
- Install upper shelf (A) to leg frames (B) using bolts (N) and nuts (X) Do not tighten. (Install the upper shelf first, remembering that the cart is upside down so for assembly this will be the lower of the 2, closest to the top frame (C).) Now install the lower shelf using bolts (N) and nut (X). Use the holes closet to the wheels for this shelf. After both shelves are secured you can tighten all bolts and nuts from step 1.

Step 2

- Cover the holes of the legd on both sides with bolts (U) and Nuts (XA) using allen key (RM). Additional towel bar accessories shall be attached here where you can purchase

Step 3

- Install the 2 drawer handles (J) to the drawer fronts using bolts (O) and a Phillips head screw driver. Please note that drawer handles (J) and bolts (O) are currently installed on the inside of the drawer for shipping. Insert Trash ring (L) into opening in the back panel of top frame (C) or replace with a Chef pan accessories where you can purchased

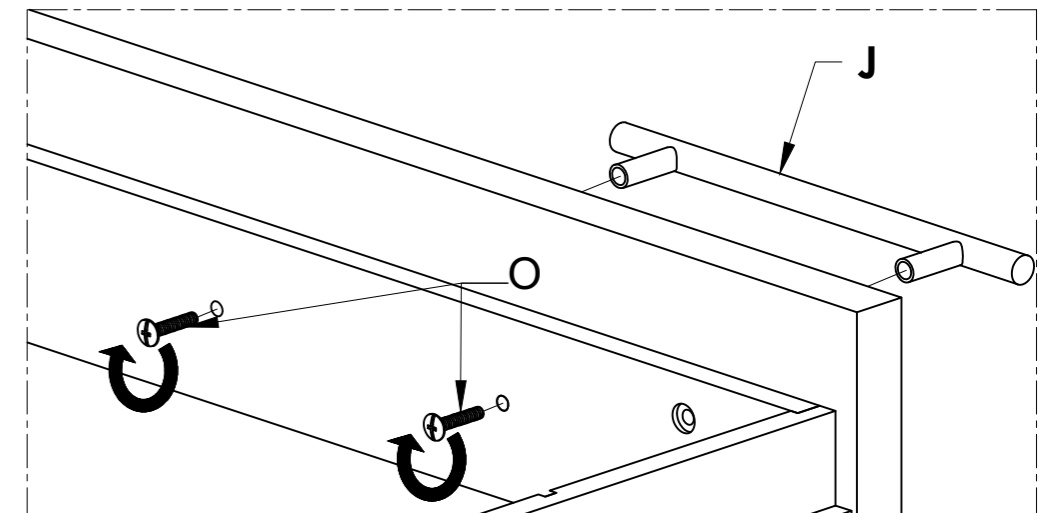

CONGRATULATIONS!

Your Chef Work and Storage station is now ready for years of service.

STEP 2.

Hardware Identification

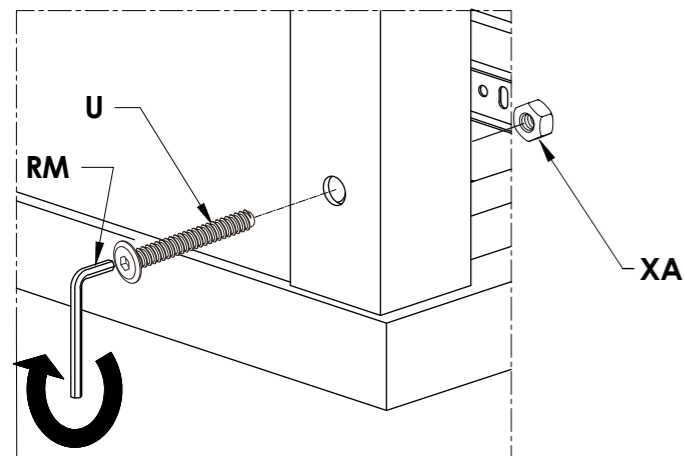
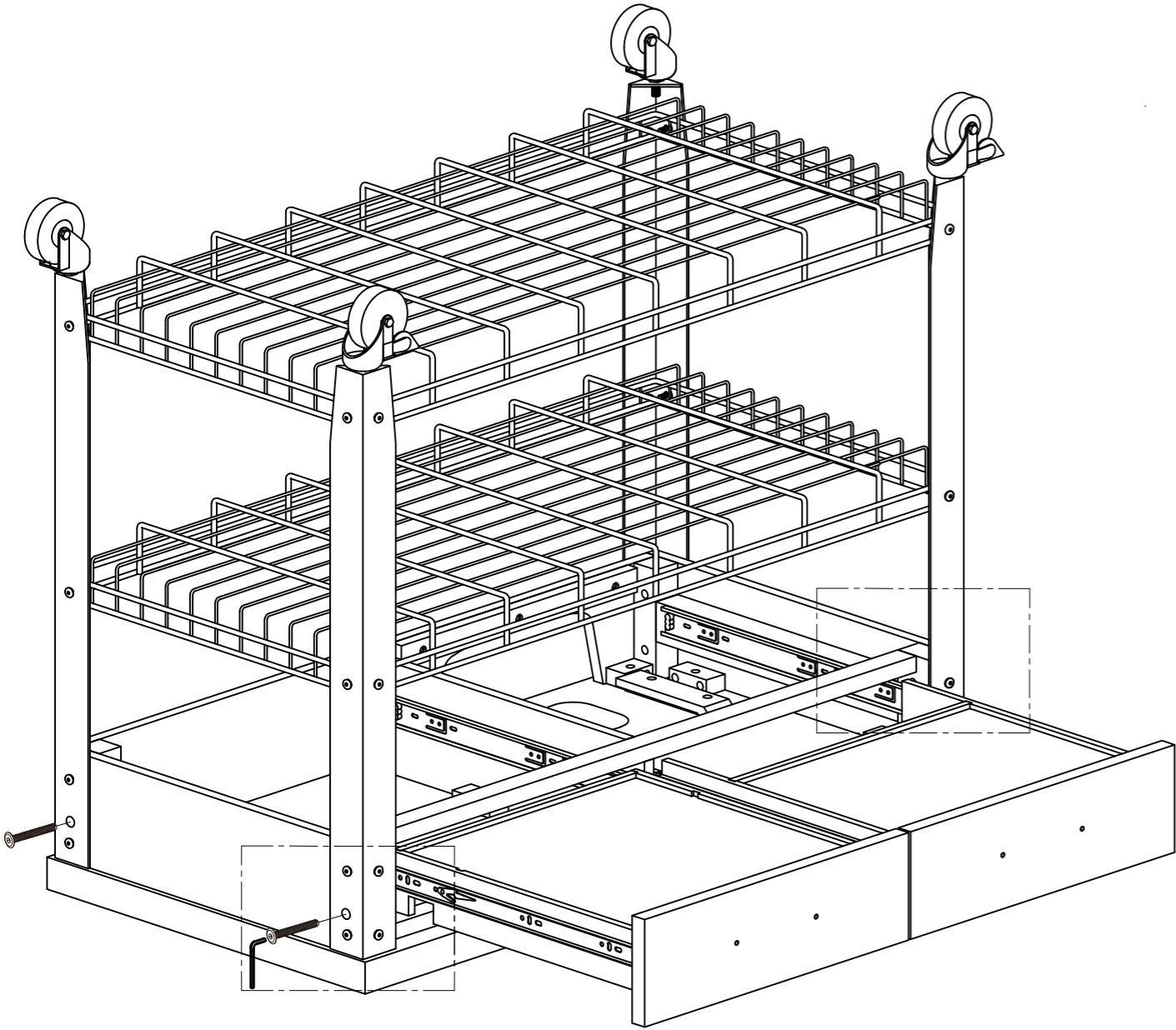

BW.BRAKE WHEEL

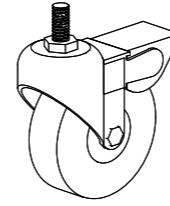

2-EACH

W.WHEEL



2-EACH

N.SHORT BOLT JCB



32-EACH

RM.ALLEN KEY



1-EACH

Q.BIG WRENCH



1-EACH

U.LONG BOLT JCB



4-EACH

XA.NUT



4-EACH

O.OIL

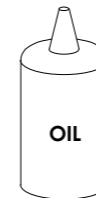

1-EACH

X.WASHER



32-EACH

Part Identification

C.TOP ASSEMBLY

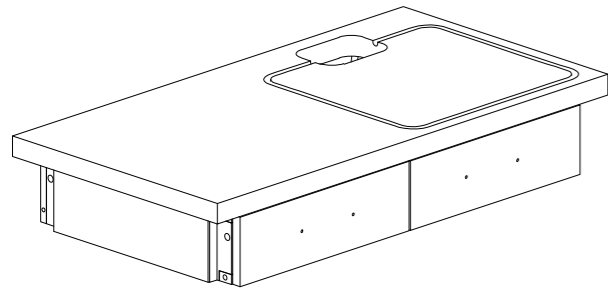

1-EACH

A.BASKET SHELF

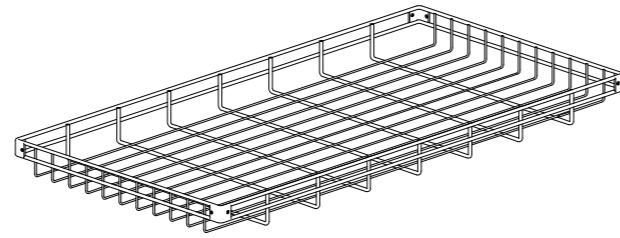

2-EACH

B.LEGS

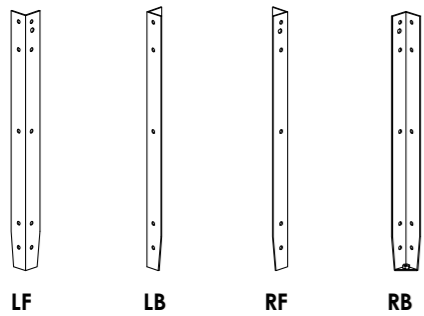

4-EACH

J.HANDLE

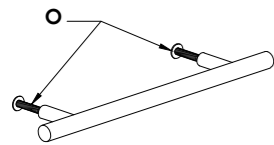

2-EACH

L.TRASH RING



1-EACH

G.TABLET HOLDER

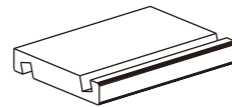

1-EACH

STEP 1.

