

Assembly Instructions

————— BED198AQ —————

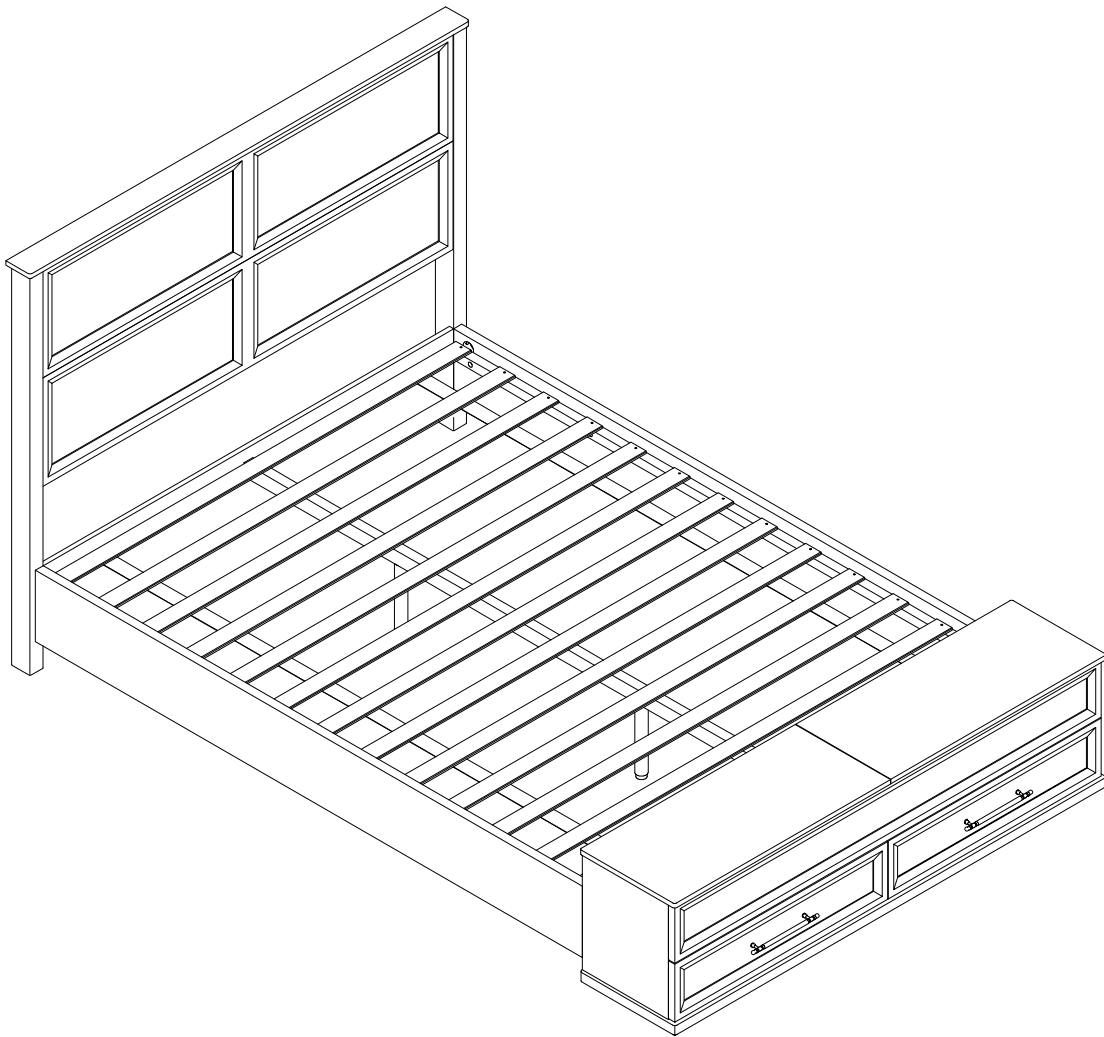

The product is packed in 2 boxes. If only a box was received, please wait for several business days or contact us for further help.

General Guidelines

- Please read the following instruction carefully and use the product accordingly.
- Please keep this manual and hand it over when you transfer the product.
- This summary may not include every detail of all variations and considered steps. Please contact us when further information and help are needed.

Notes

- The product is intended for indoor use only. The product must be assembled and used in accordance with the provisions of the manual. Personal injury and/or damage to product may occur if products are used outside of their intended purposes and/or if products have been changed/modified from their original design. The seller does not assume any responsibility or liability with respect to any injury/damage caused by incorrect assembly or improper use.
- Avoid long-term exposure to humid environments to prevent mildew.
- Keep the product away from fire sources and high temperatures. Do not expose the product to direct sunlight.
- Do not place any hot objects on the surface of the product.
- If there are any defective or missing parts after unpacking, please cease assembly immediately and contact us.
- Please assemble the item on a spacious surface and do not place the unwrapped product directly on the ground to avoid product damage.
- Please do not stand or sit on the wooden boards.
- Please wear gloves during the assembly and/or disassembly process to avoid scratches from any sharp edges.
- Please match the corresponding part and fitting based on the part number in the manual.
- If the part does not match with the fitting, please check the piece as specified in this manual.
- During assembly, first loosely align all screws with the corresponding pre-drilled holes and then tighten the screws one by one.
- Periodically inspect screw tightness while the product is in use. If necessary, retighten to ensure structural integrity.
- If you accidentally spill water or another liquid on the surface, immediately wipe clean with a dry towel.
- Please keep the product away from sharp, pointed objects and corrosive substances to prevent product damage.
- Please place this item on level, solid ground during use.

Warnings

- During assembly, keep all small parts out of the reach of children. It may be fatal if swallowed or inhaled.
- Children should not climb or play on the product in order to avoid tipping over the furniture and causing serious injury.
- To avoid the potential dangers of suffocation, please keep all parts and packaging (film, plastic bags, foam, etc.) away from babies and children.
- Keep sharp objects and corrosive items away from the product to avoid any damage or injury.
- Do not shake or move violently during use to avoid tipping over the product.

Parts List (EN)

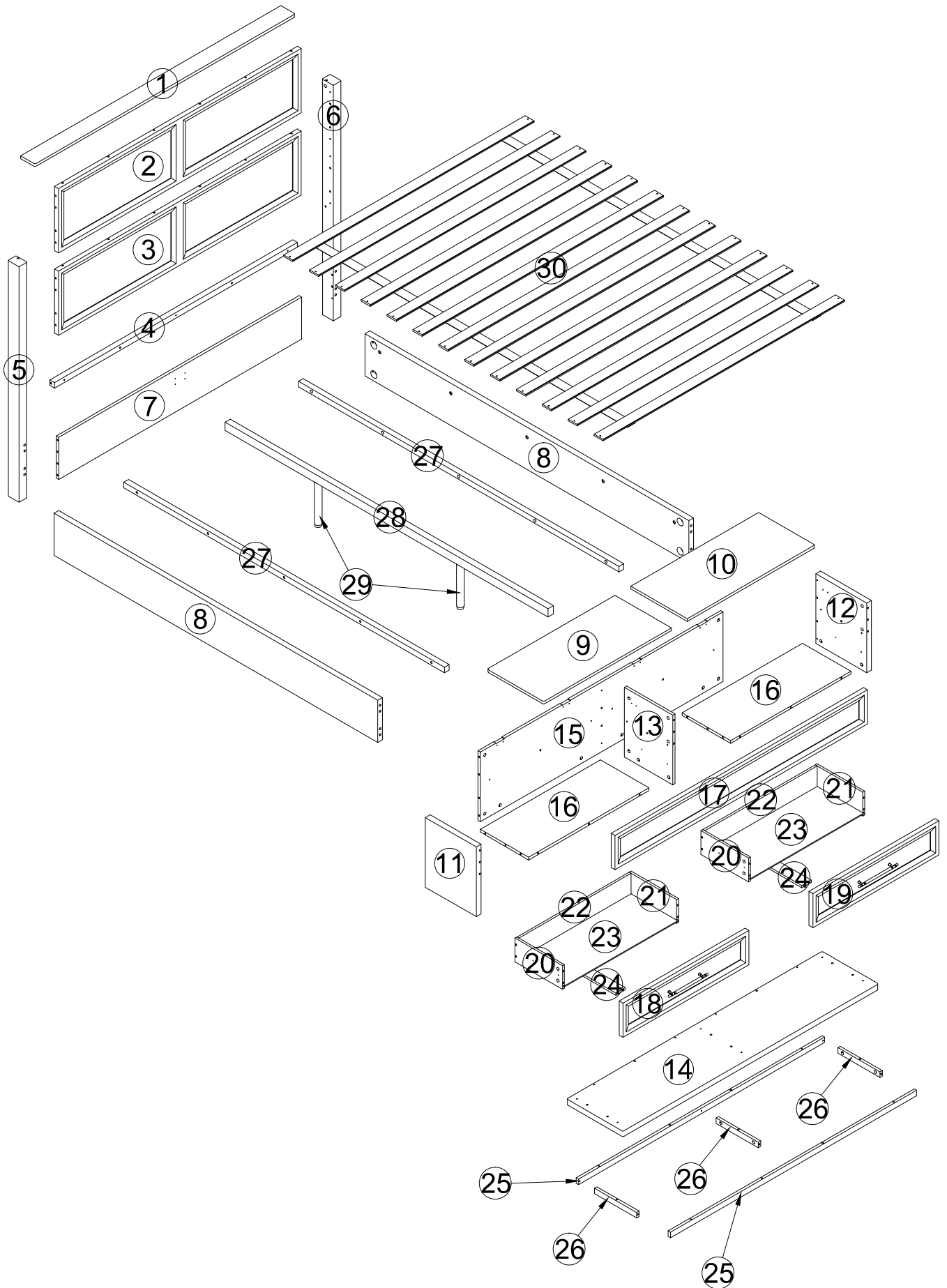

Parts List (EN)

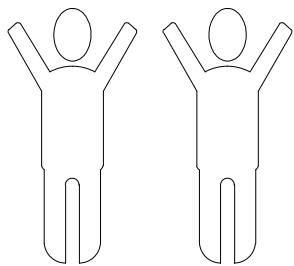

It takes two people to work together to assemble the product.

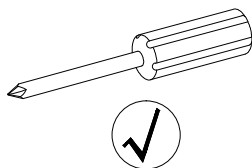

Recommended to use a screwdriver to assemble the product

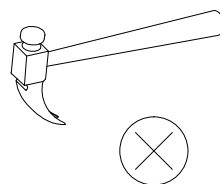

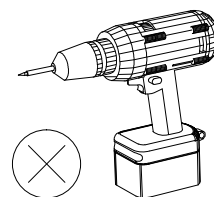

Do not use a hammer, it might damage the board.



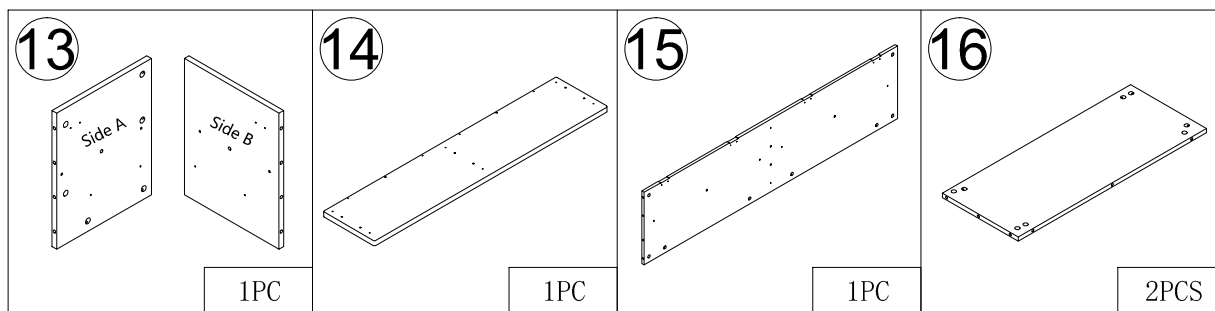
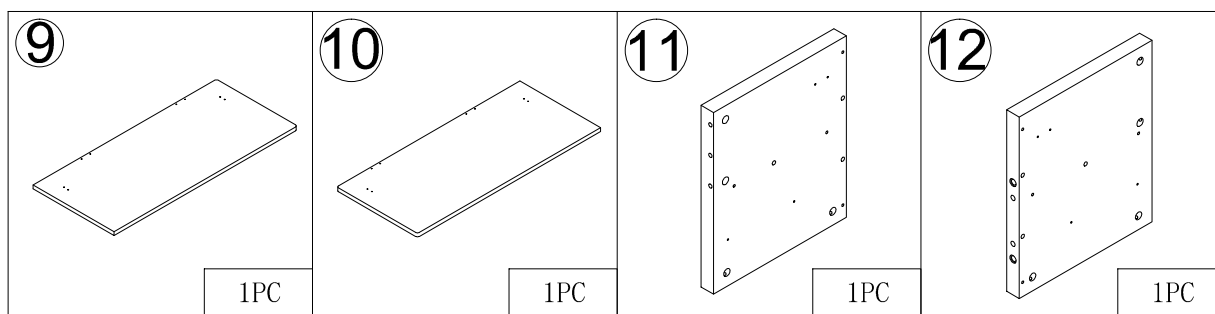
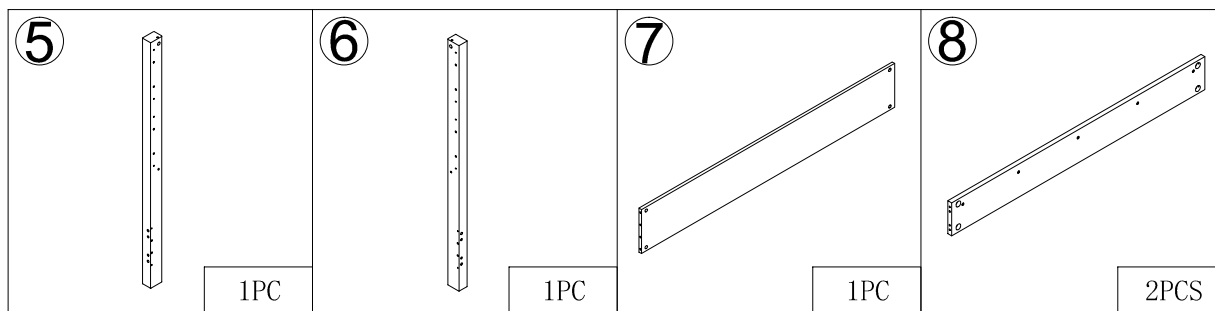
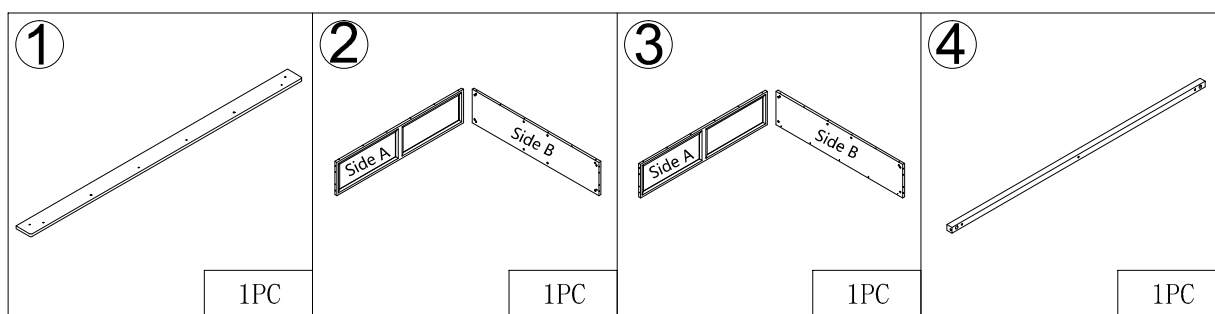



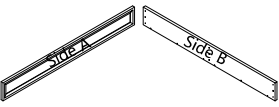
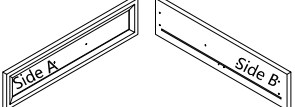
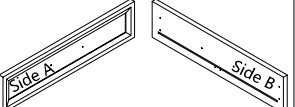
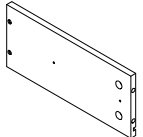
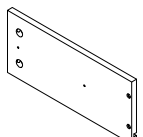
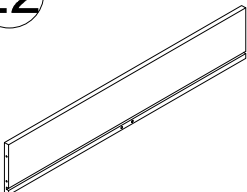
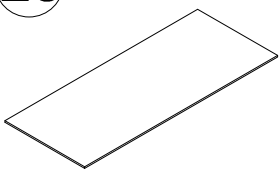
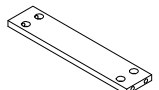
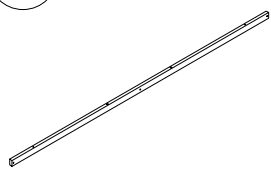
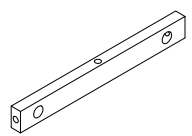
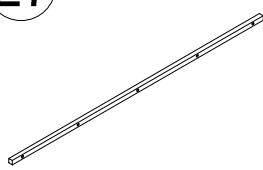
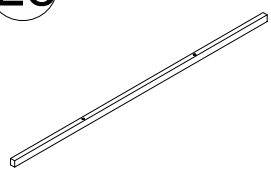

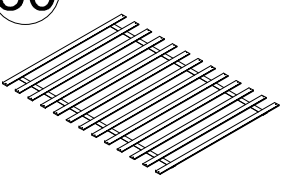

The use of an electric wrench is not recommended. If used, please set the torque to the minimum.



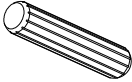
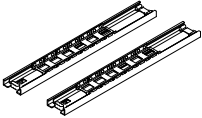

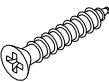
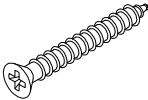

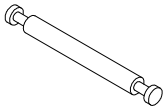
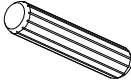
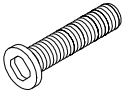
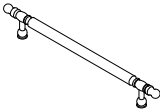
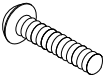

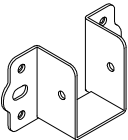
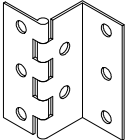
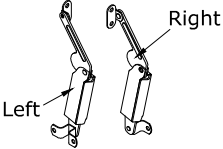
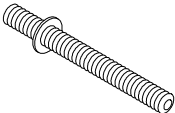

Parts List (EN)

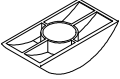
<p>17</p>  <p>1PC</p>	<p>18</p>  <p>1PC</p>	<p>19</p>  <p>1PC</p>	<p>20</p>  <p>2PCS</p>
<p>21</p>  <p>2PCS</p>	<p>22</p>  <p>2PCS</p>	<p>23</p>  <p>2PCS</p>	<p>24</p>  <p>2PCS</p>
<p>25</p>  <p>2PCS</p>	<p>26</p>  <p>3PCS</p>	<p>27</p>  <p>2PCS</p>	<p>28</p>  <p>1PC</p>
<p>29</p>  <p>2PCS</p>	<p>30</p>  <p>1PC</p>		

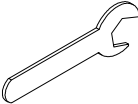
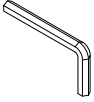
Parts List (EN)

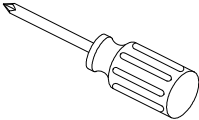
<p>No. A Quantity:78+4 Pcs Cam Lock Dowel 8*28mm</p> 	<p>No. B Quantity:86+4 Pcs Cam φ15</p> 	<p>No. C Quantity:9+1 Pcs Sticker Ø20</p> 	<p>No. D Quantity:48+3 Pcs Dowel 8*30mm</p> 
<p>No. E Quantity:2 Sets Drawer Slider 10"</p> 	<p>No. F Quantity:56+4 Pcs Screw M3.5*14mm</p> 	<p>No. G Quantity:2+1 Pcs Screw M3.5*25mm</p> 	<p>No. H Quantity:41+3 Pcs Screw M4*30mm</p> 
<p>No. I Quantity:8+1 Pcs Foot Pad Ø20</p> 	<p>No. J Quantity:4+1 Pcs Double-ended rod 6*64mm</p> 	<p>No. K Quantity:8+1 Pcs Dowel 10*40mm</p> 	<p>No. L Quantity:10+1 Pcs Screw M8*35mm</p> 
<p>No. M Quantity:2 Pcs</p> 	<p>No. N Quantity:4+1 Pcs Screw M4*18mm</p> 	<p>No. O Quantity:2 Pcs Adjust The Foot</p> 	<p>No. P Quantity:2+3 Pcs Rubber particles Ø10</p> 
<p>No. Q Quantity:2 Pcs U-shaped hardware 86*45*30</p> 	<p>No. R Quantity:4 Pcs Hinge</p> 	<p>No. S Quantity:2 Sets Support rod</p> 	<p>No. T Quantity:4+1 Pcs Full tooth screw M8*80mm</p> 

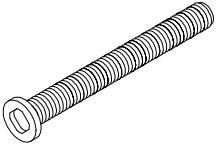
Parts List (EN)

<p>No. U Quantity: 8 Pcs Gasket 29*15*7</p> 	<p>No. V Quantity: 8 Pcs Hex nut M8</p> 	<p>No. W Quantity: 1 Pc Wrench</p> 	<p>No. X Quantity: 1 Pc Allen Key 5#</p> 
<p>No. Y Quantity: 4 Pcs Glove</p> 	<p>No. Z Quantity: 1 Pc Screwdriver</p> 	<p>No. A-1 Quantity: 8+1 Pcs Screw M3.5*12mm</p> 	<p>No. A-2 Quantity: 4+1 Pcs Screw M8*130mm</p> 
<p>No. A-3 Quantity: 4+1 Pcs Gasket</p> 			

Instructions For Fastening CAM-BOLT and CAM-LOCK

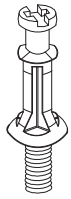

CAM-BOLT



CAM-LOCK

Tools Required

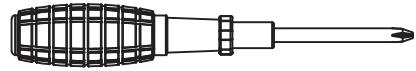

INSERTING AND TIGHTENING CAM-BOLT

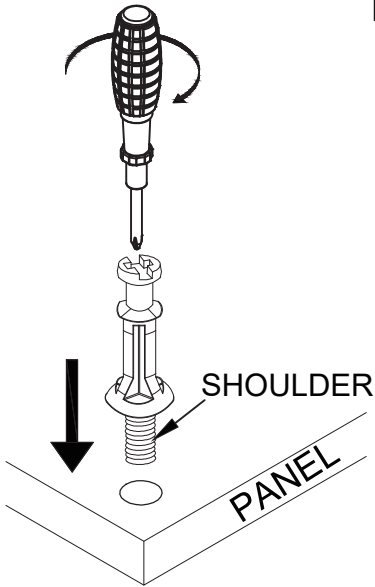

Place Cam-bolt on pre-drilled hole and screw in vertically

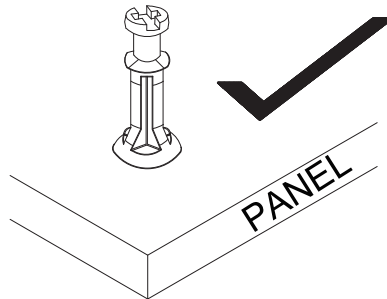

Shoulder is flushed (on the same level) with the panel.

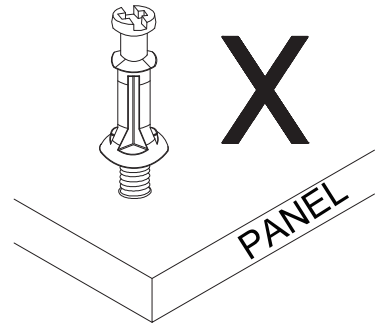

Shoulder is above the panel.

Place Cam-bolt on the designated pre-drilled holes on the panel. Use a Phillips Screwdriver to screw-in Cam-bolt vertically until shoulder is flushed (on the same level) with panel.

INSERTING CAM-LOCK

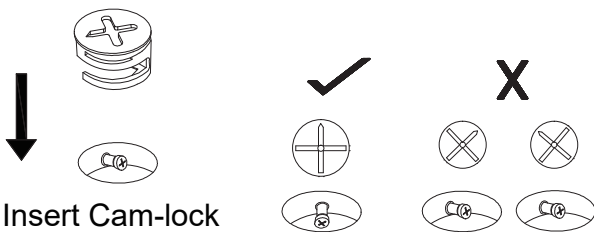

Insert Cam-lock with arrow align to Cam-bolt head

CORRECT

WRONG

TIGHTENING CAM-LOCK

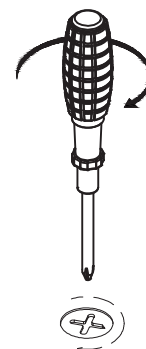

Align the arrow on the Cam-lock to the Cam-bolt head and insert the Cam-lock. Ensure Cam-lock is fully inserted.

Use a Flat-head Screwdriver to turn Camlock clockwise so it locks onto the head of the Cam-bolt. Turn until it is snug (about 3/4ths of a turn) -- over-tightening could damage Cam-lock or/and Cam-bolt.

STEP 1

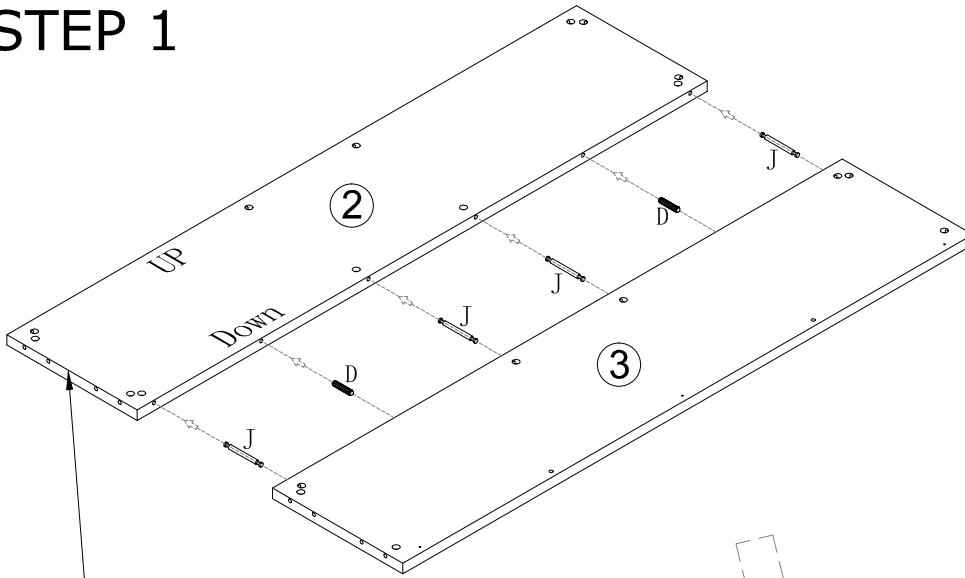

! Align the arrow on the Cam-lock to the Cam-bolt head and insert the Cam-lock. Ensure Cam-lock is fully inserted.

Please note that this board is assembled in an up-down manner, and there are labels on the components, assemble according to the marked direction.

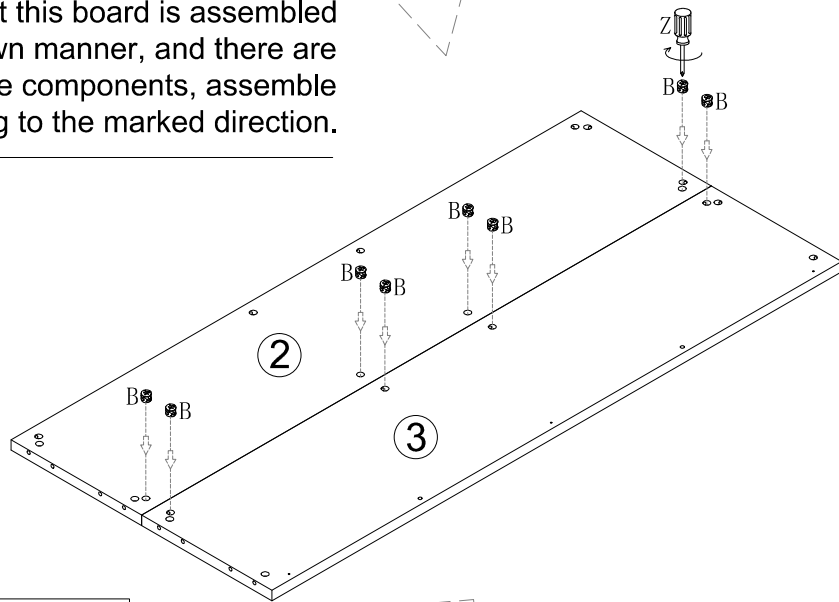

INSERTING AND TIGHTENING CAM-BOLT

Insert Cam-lock with arrow align to Cam-bolt head

CORRECT

WRONG

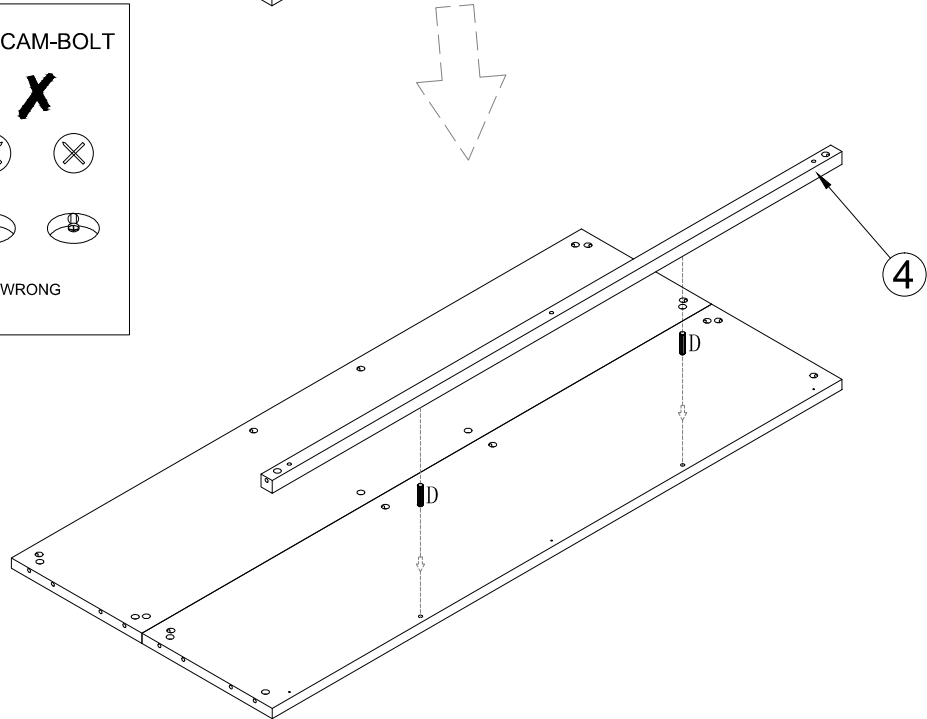

	B×8PCS
	D×4PCS
	J×4PCS

STEP 2

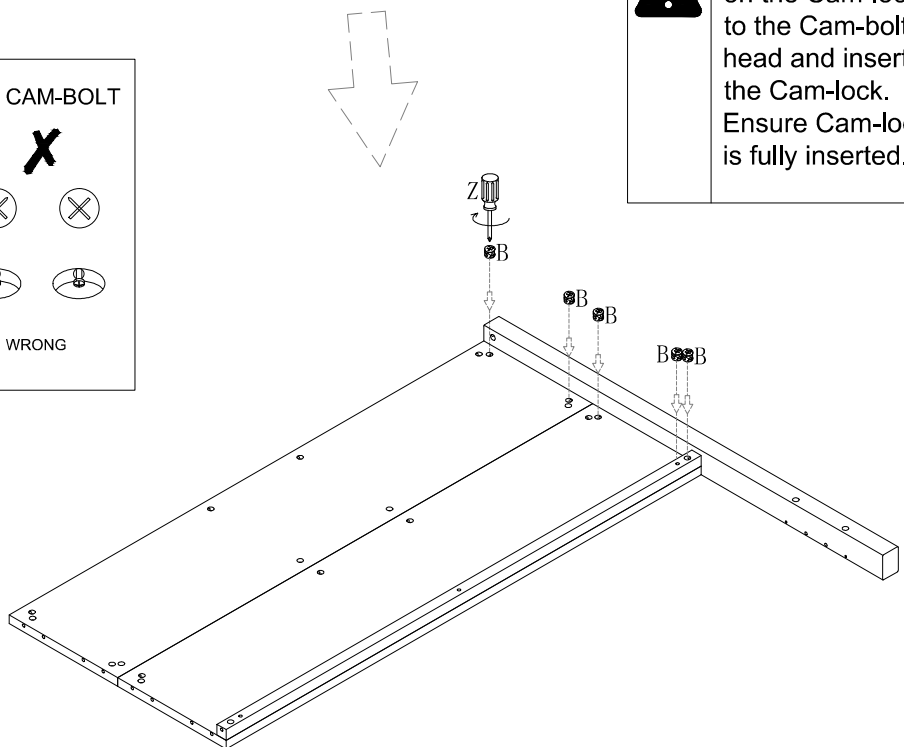
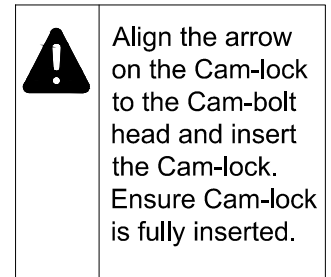
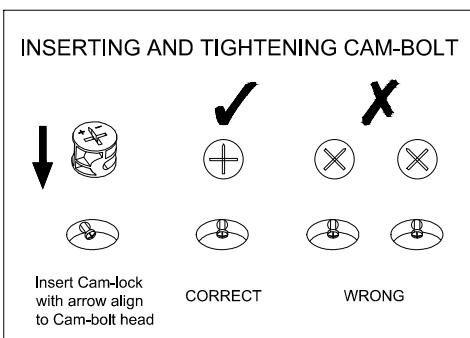
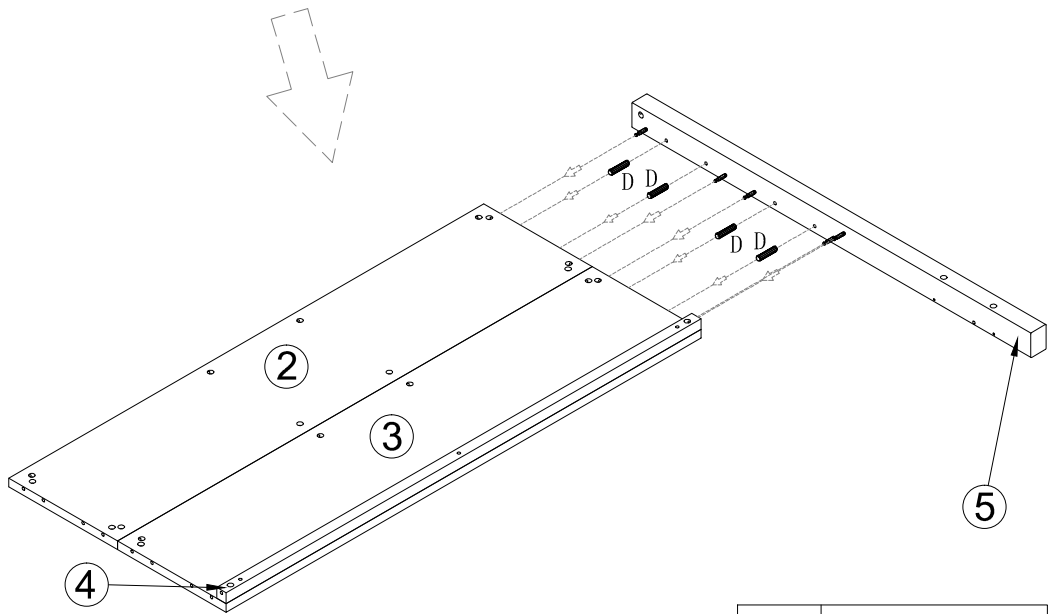
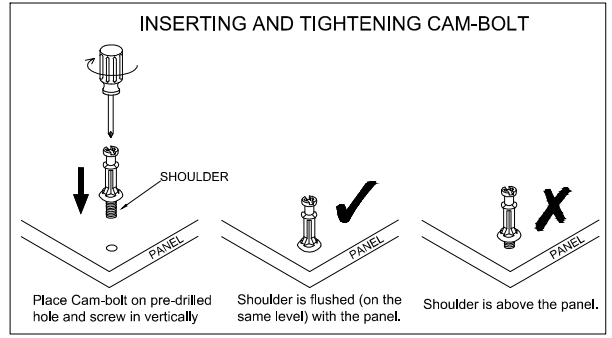
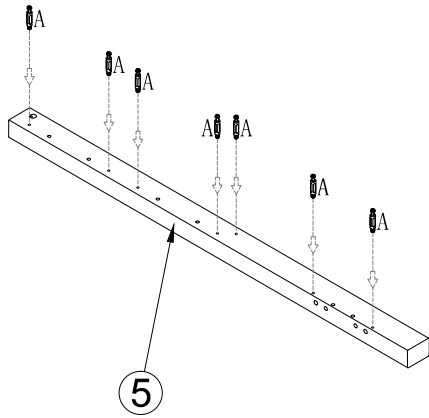

	A×7PCS
	B×5PCS
	D×4PCS

STEP 3

Note: After installation, the narrow edge of the hole margin should face upwards.

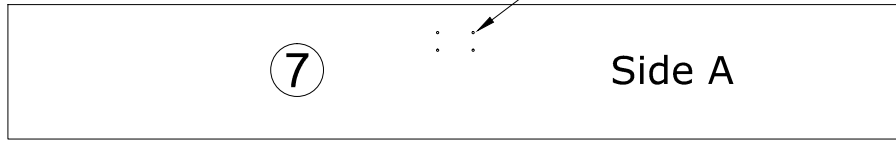

Note that when assembling the No.7 plate, the middle locating hole is facing down.



INSERTING AND TIGHTENING CAM-BOLT

Insert Cam-lock with arrow align to Cam-bolt head

CORRECT WRONG



Align the arrow on the Cam-lock to the Cam-bolt head and insert the Cam-lock. Ensure Cam-lock is fully inserted.

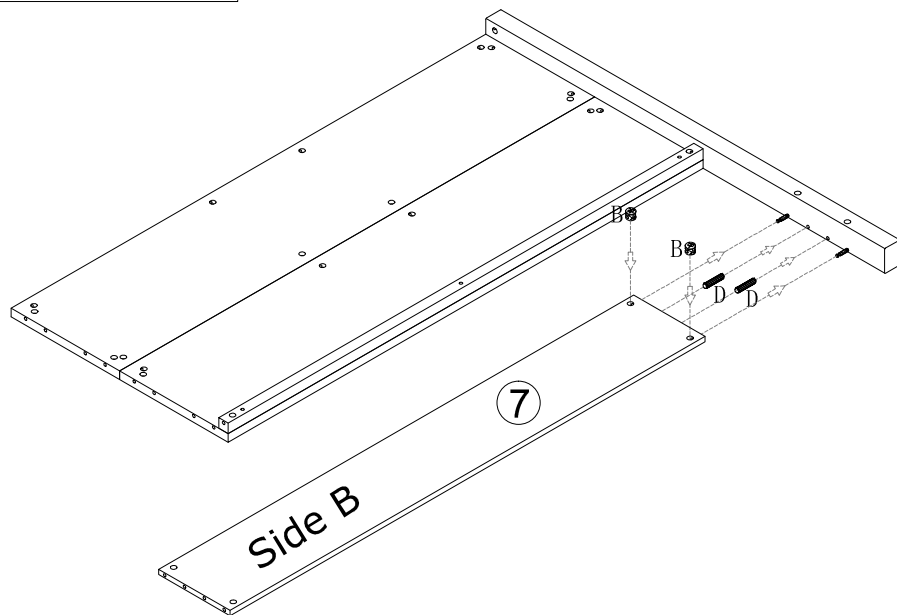

	B×2PCS
	D×2PCS

STEP 4

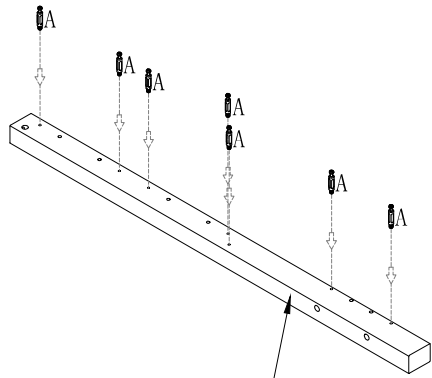

6

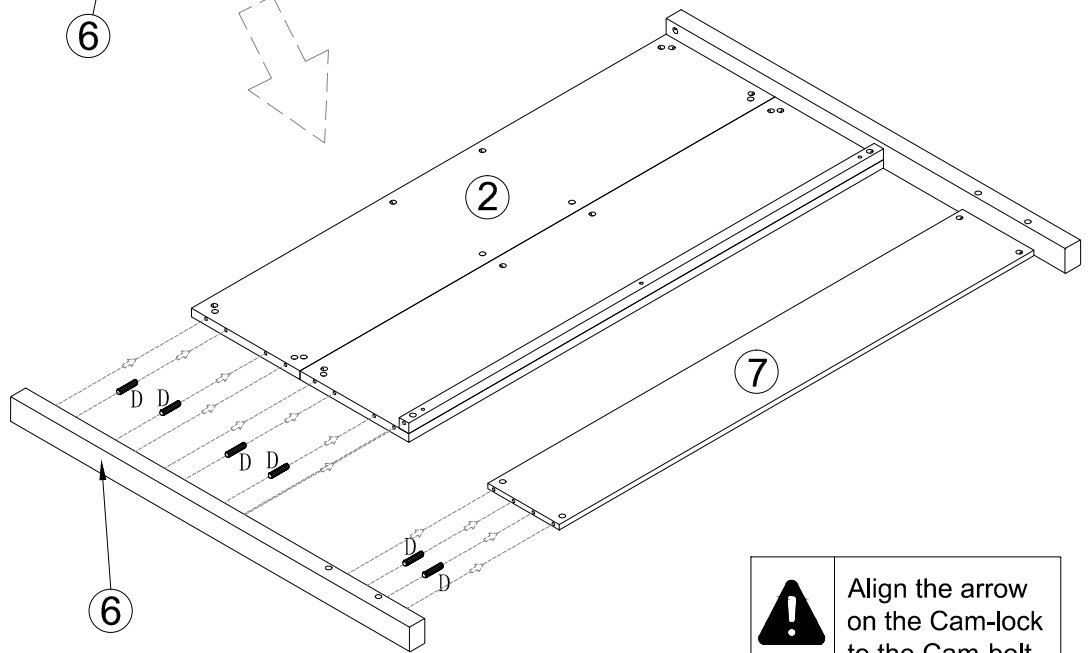
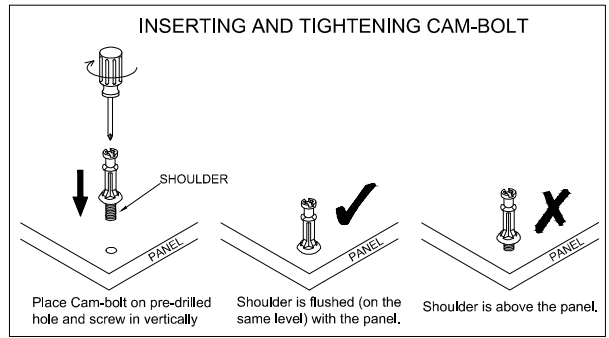

6

2

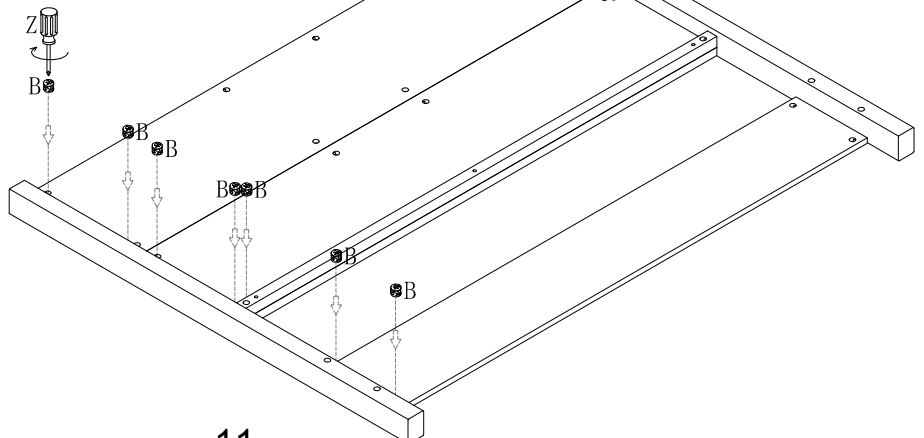
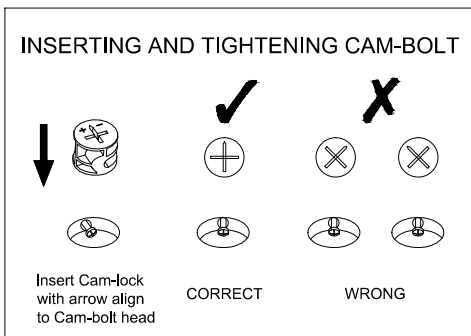
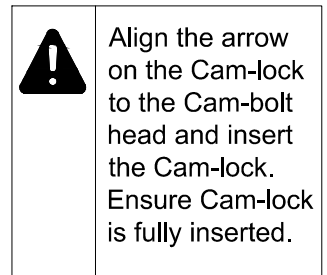

7



	A×7PCS
	B×7PCS
	D×6PCS

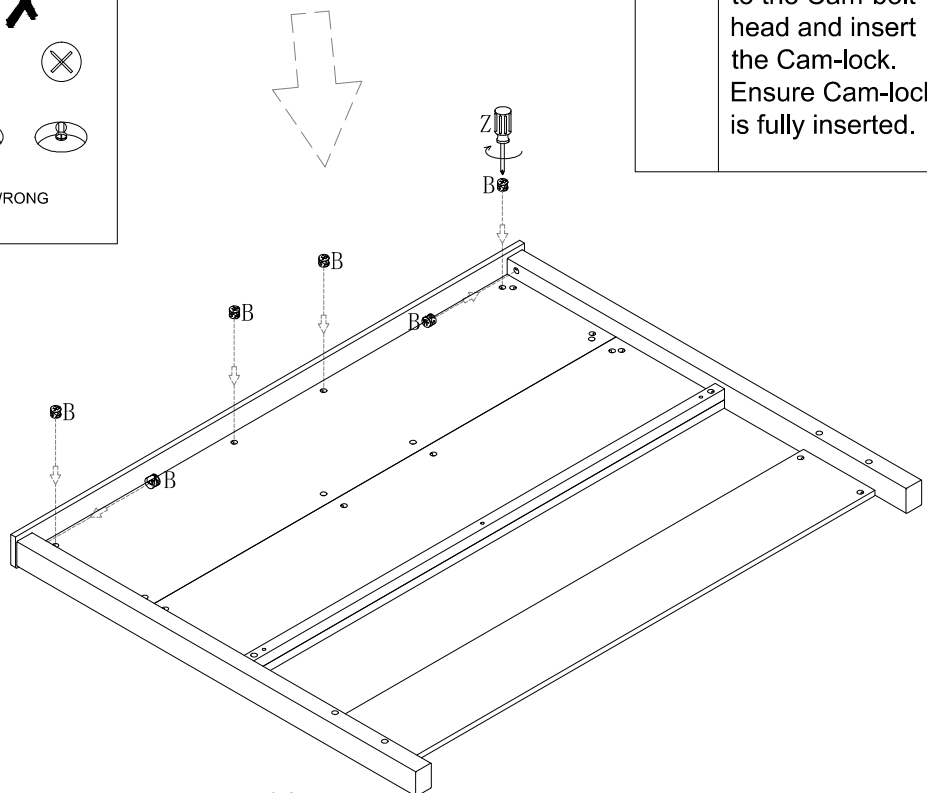
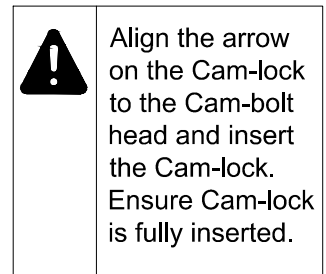
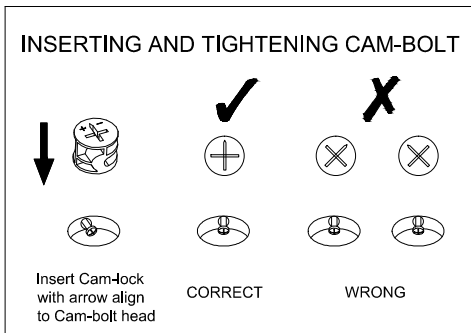
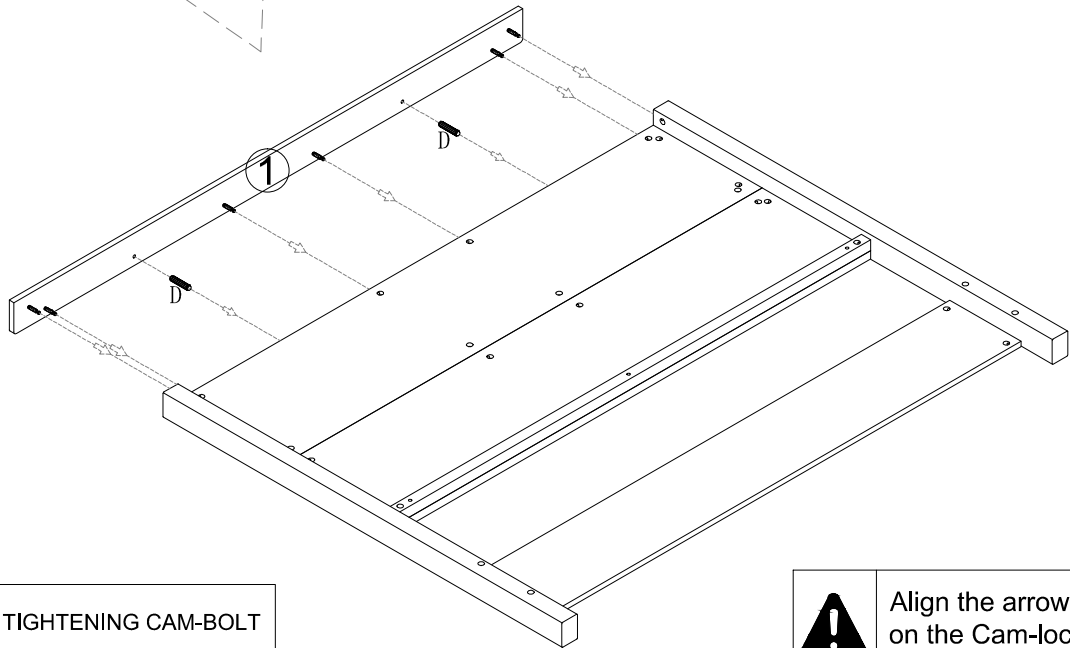
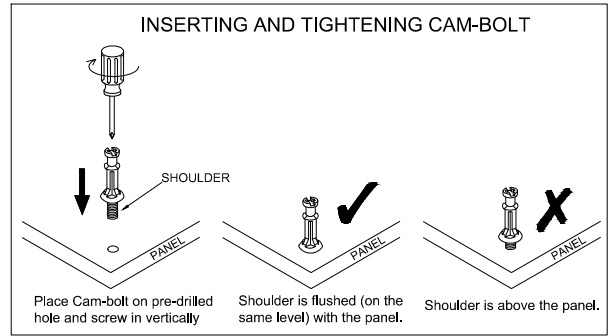
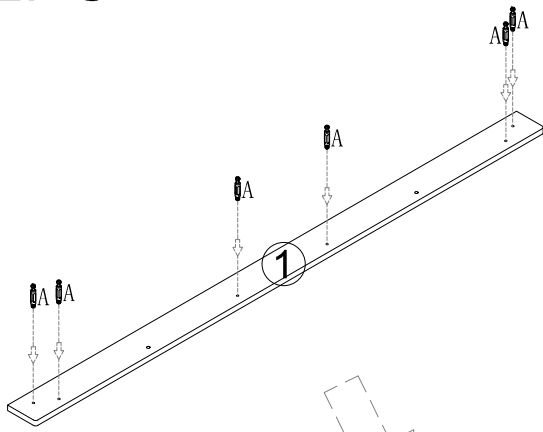

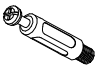
STEP 5

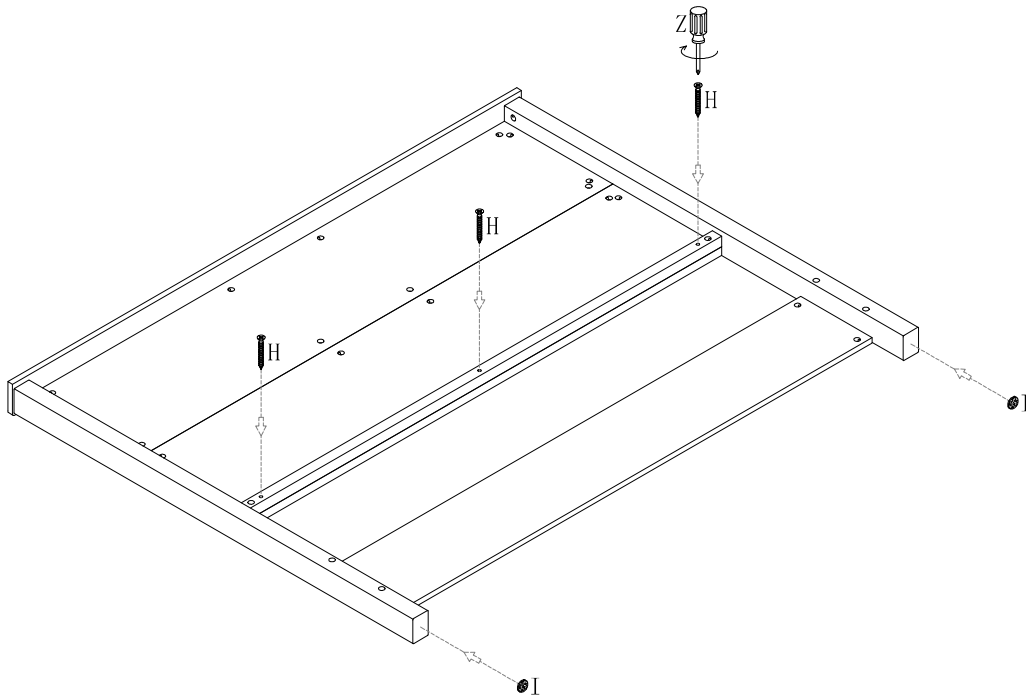

	A×6PCS
	B×6PCS
	D×2PCS

STEP 6



	H×3PCS
	I×2PCS

STEP 7

Before Assembly

Tips Before Your Start

How to separate the drawer slider:

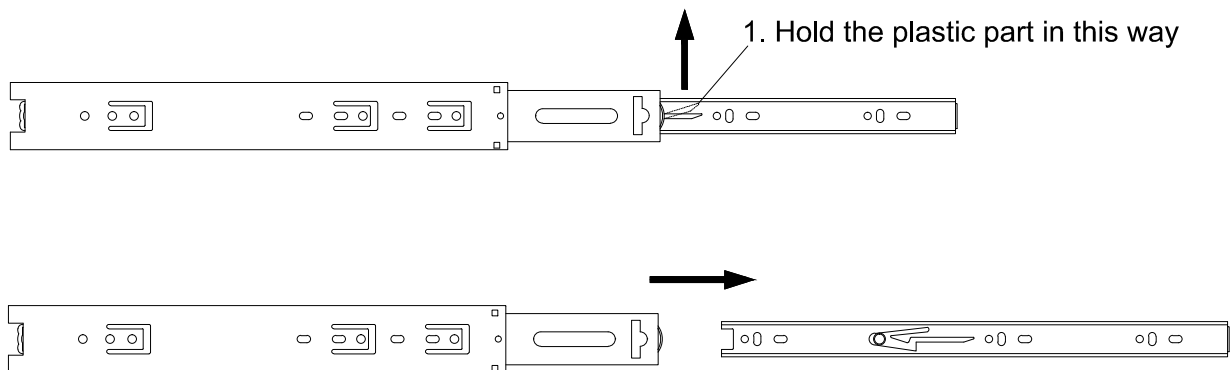

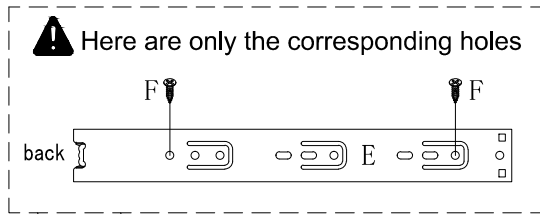

2. Pull out the inner slider for drawer box fixing

STEP 8

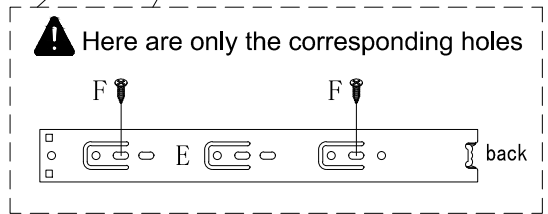
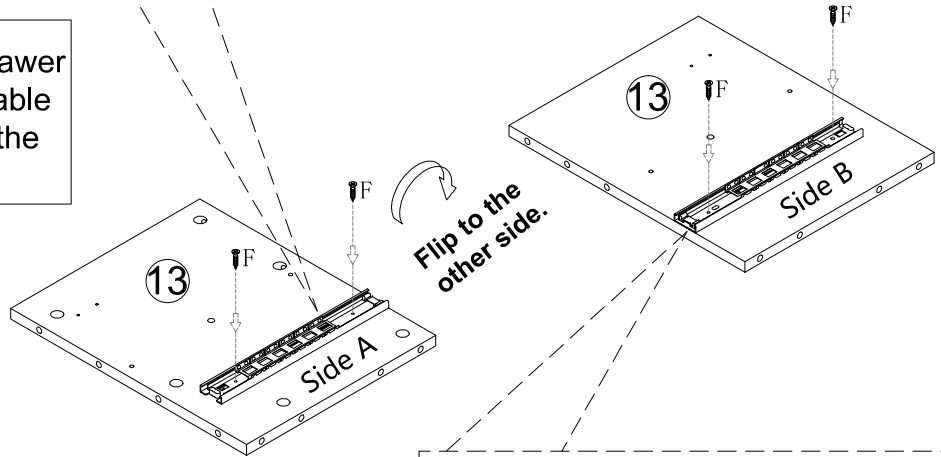

! Please pull the drawer slide out to a suitable position to install the screws.





	E×1Sets
	F×4PCS

STEP 9

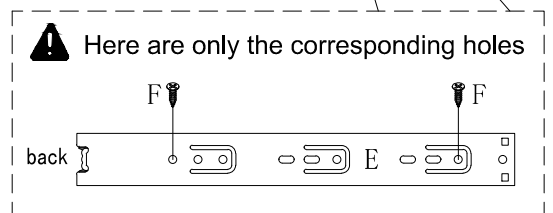
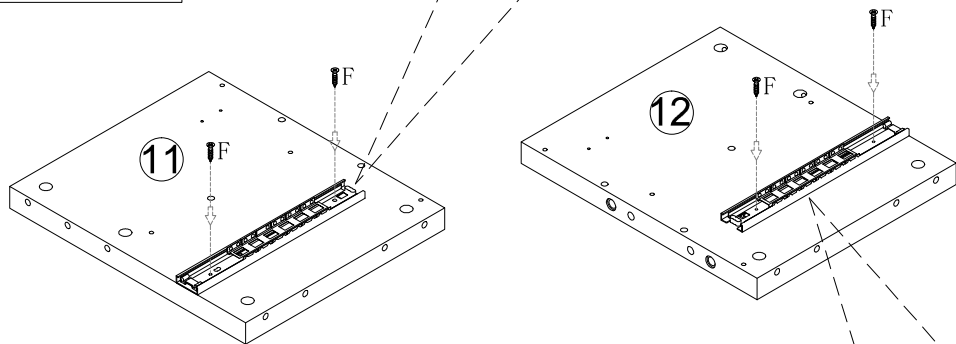
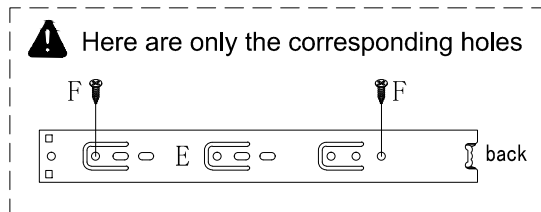
! Please pull the drawer slide out to a suitable position to install the screws.



	E×1Sets
	F×4PCS

STEP 10

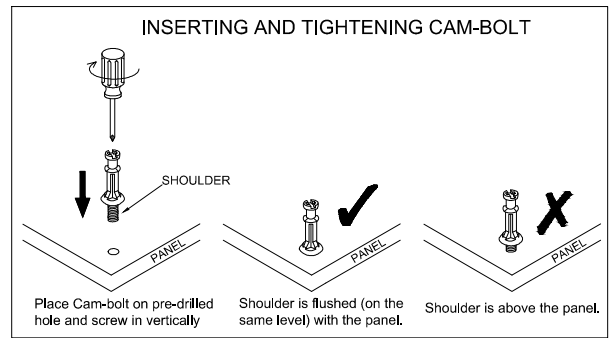
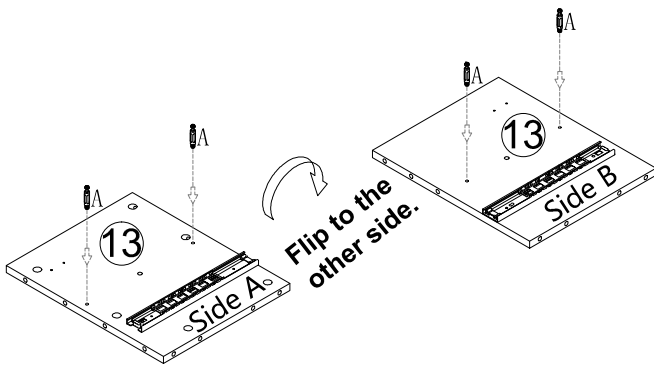

Please make sure to distinguish between left and right during installation; the hole on the right should be slightly lower than the one on the left.

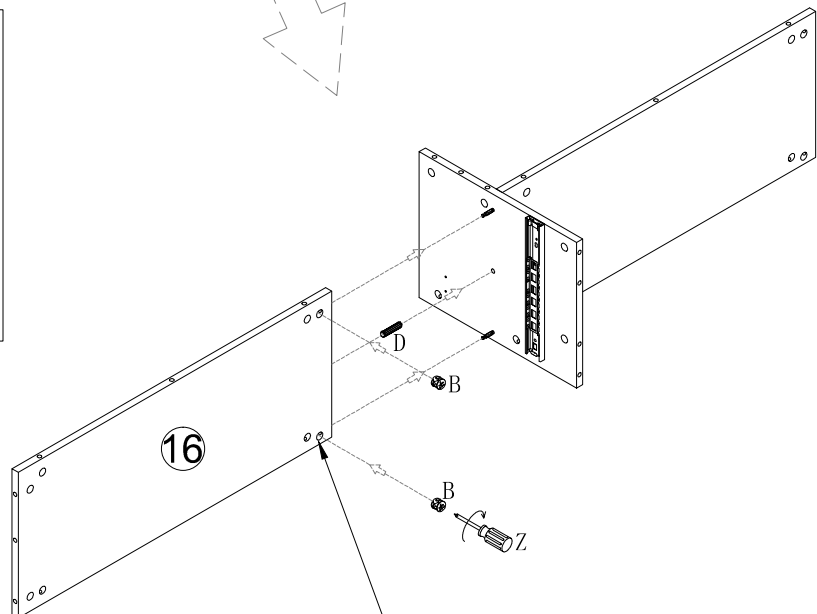
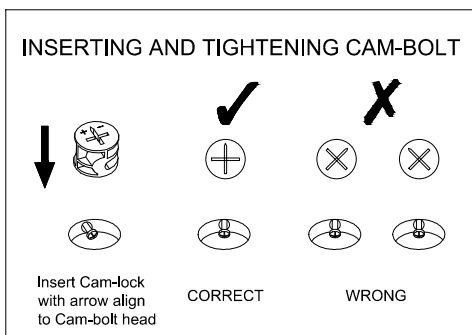
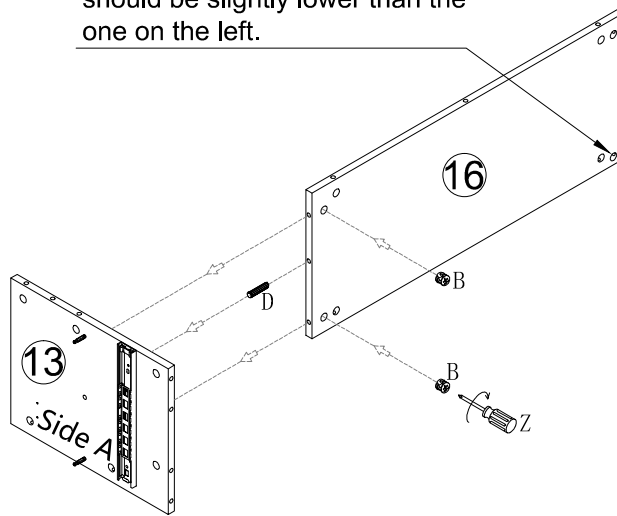
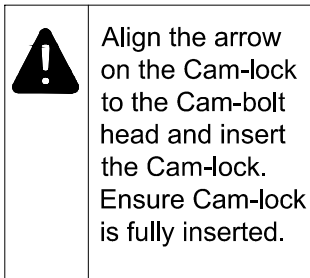

Please make sure to distinguish between left and right during installation; the hole on the right should be slightly lower than the one on the left.

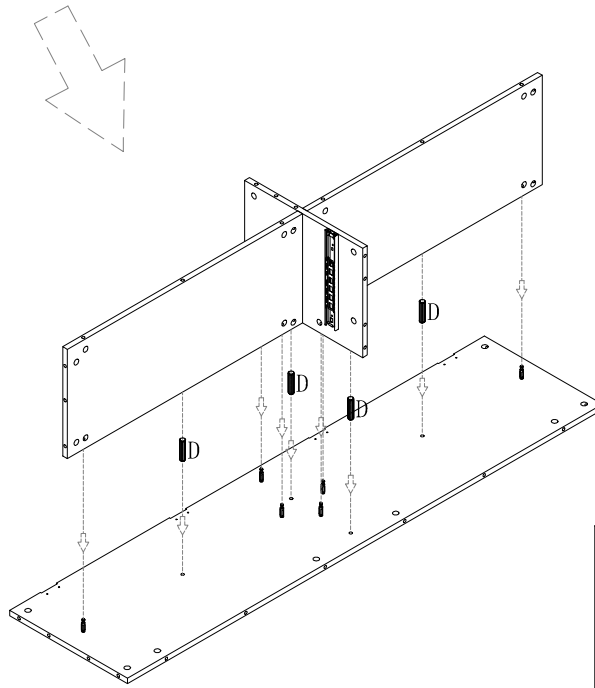
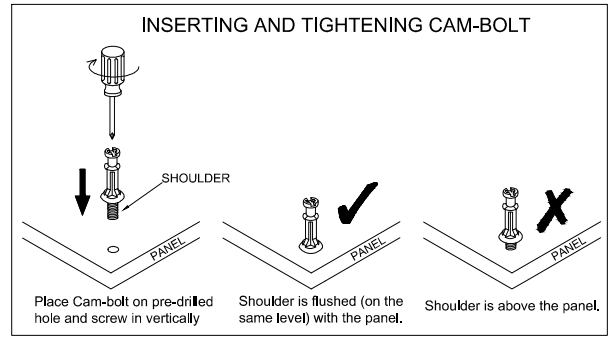
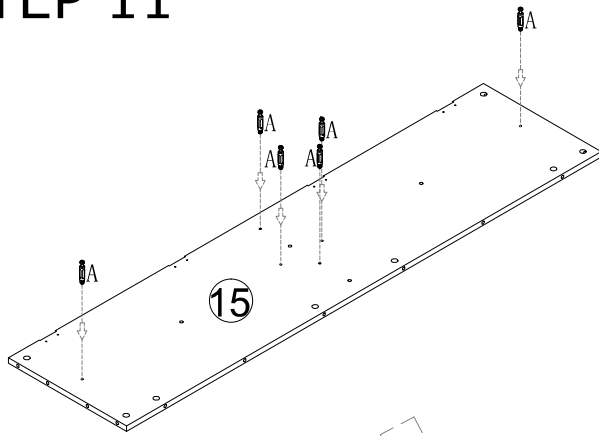

	A×4PCS
	B×4PCS
	D×2PCS

STEP 11

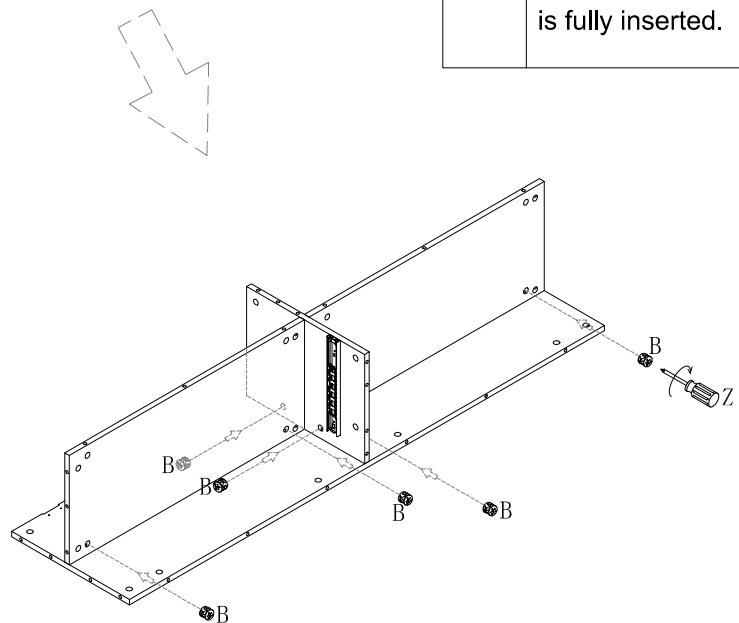
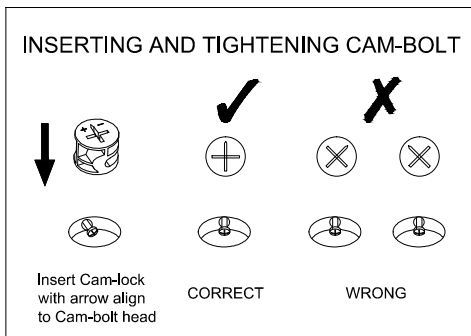

Align the arrow on the Cam-lock to the Cam-bolt head and insert the Cam-lock. Ensure Cam-lock is fully inserted.



	A×4PCS
	B×4PCS
	D×2PCS

STEP 12

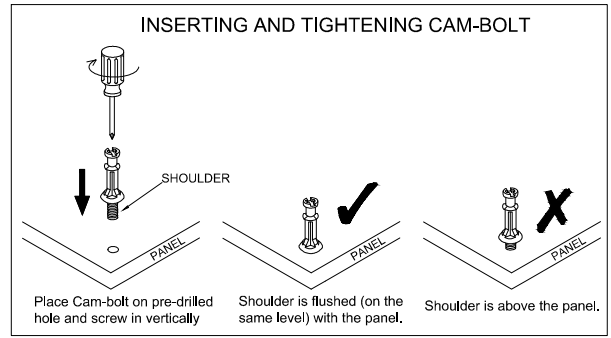
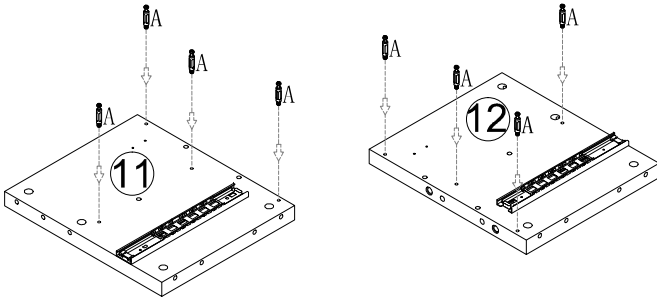

! Align the arrow on the Cam-lock to the Cam-bolt head and insert the Cam-lock. Ensure Cam-lock is fully inserted.

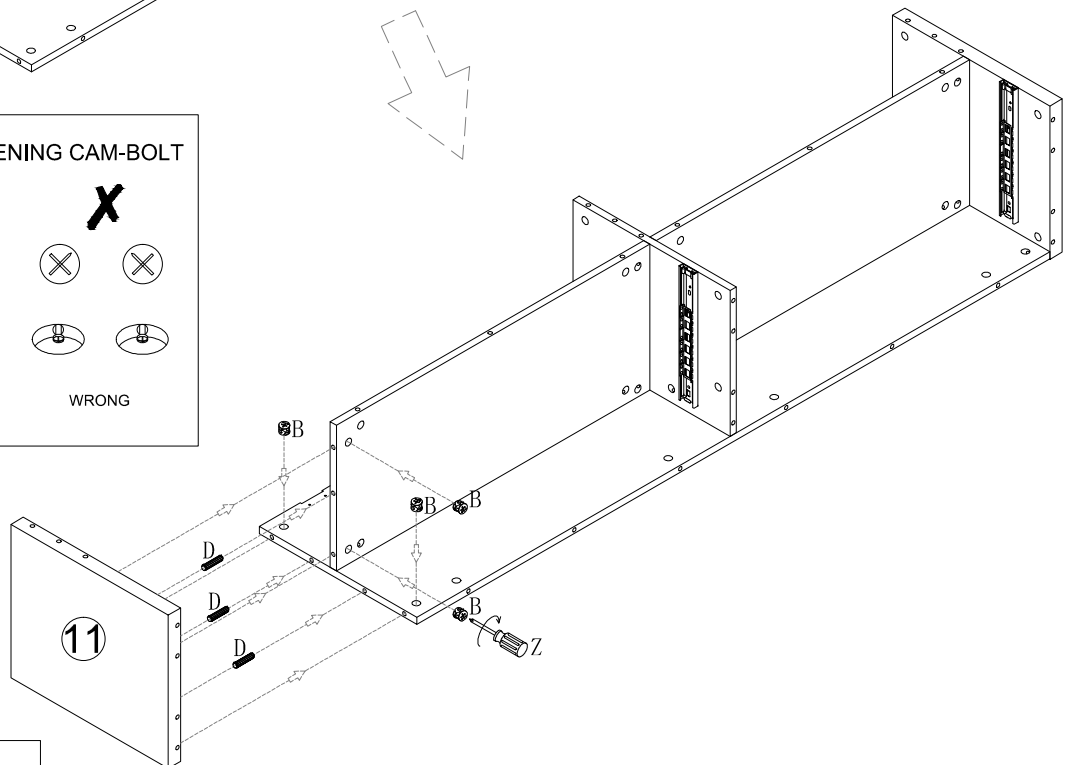
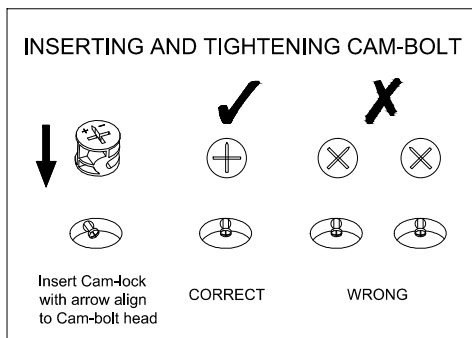
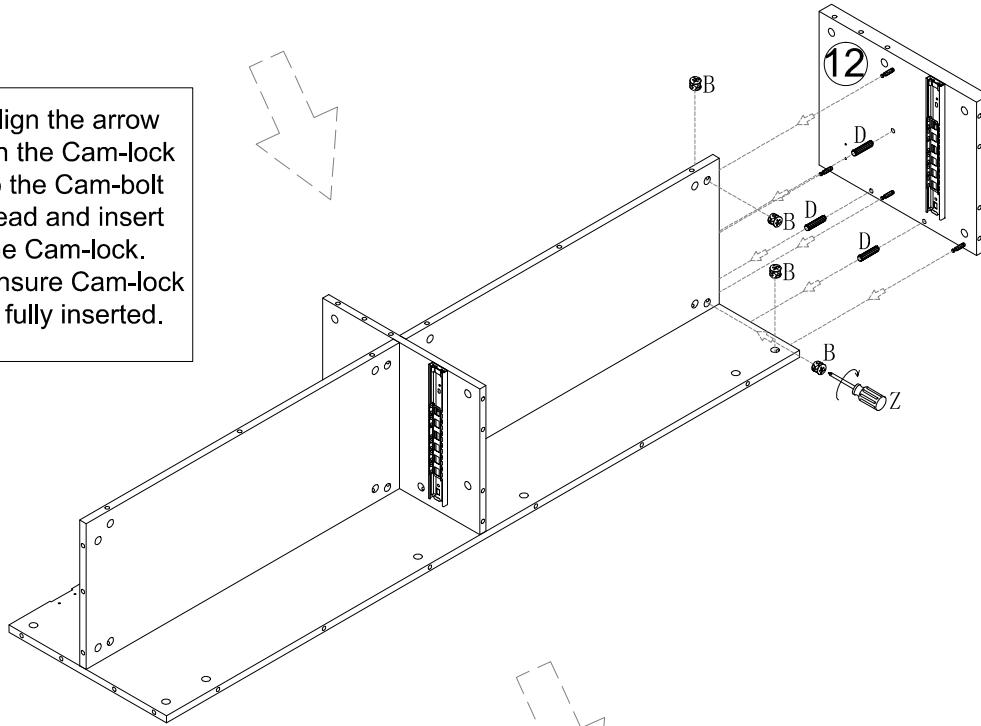

	A×8PCS
	B×8PCS
	D×6PCS

STEP 13

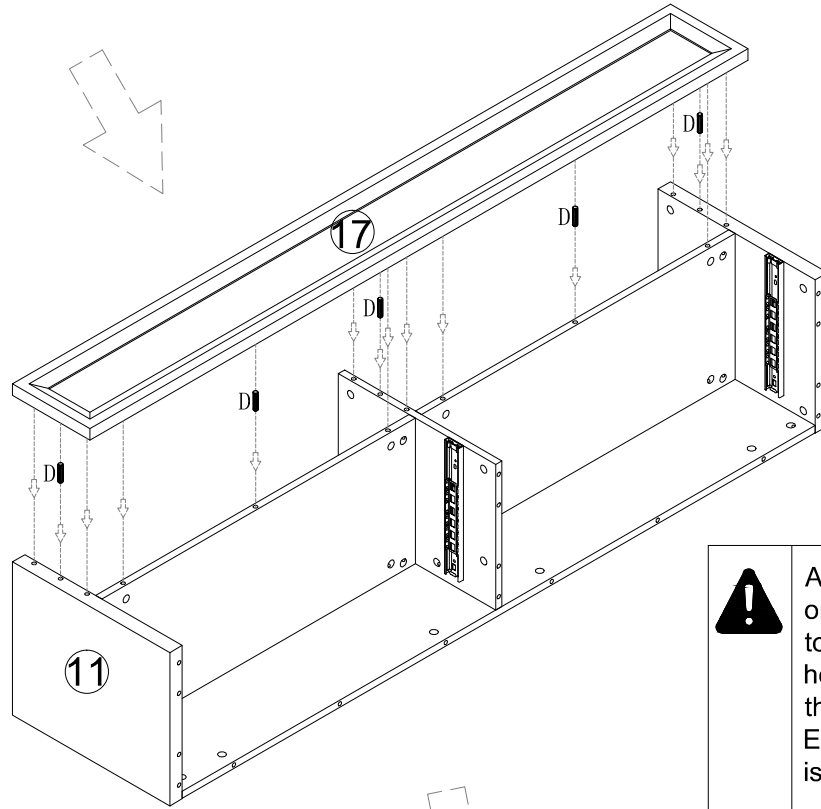
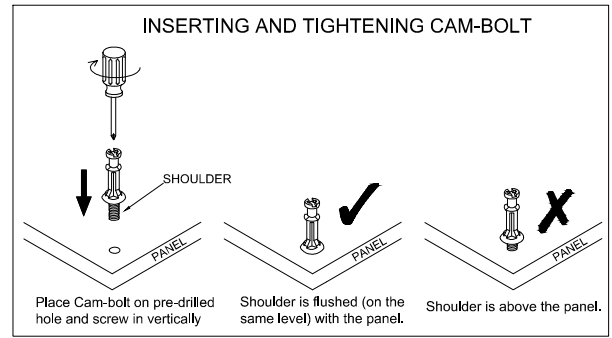
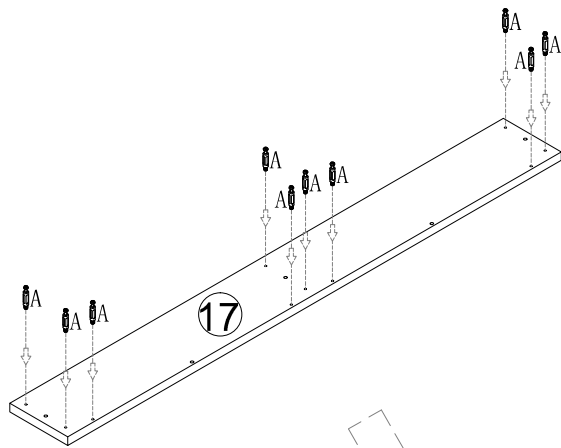

! Align the arrow on the Cam-lock to the Cam-bolt head and insert the Cam-lock. Ensure Cam-lock is fully inserted.

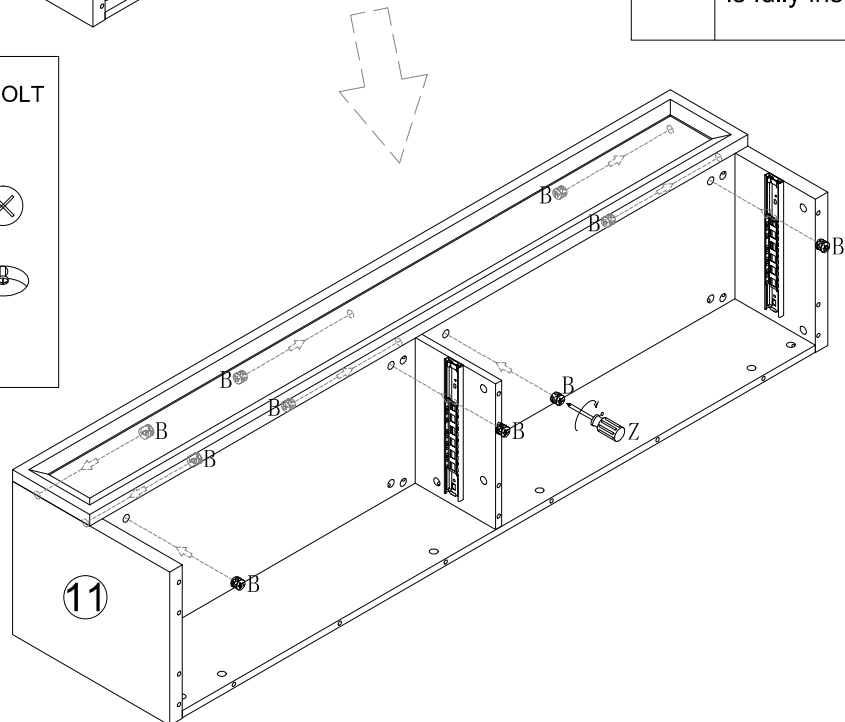
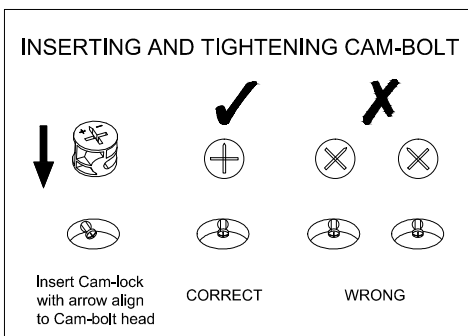

	A×10PCS
	B×10PCS
	D×5PCS

STEP 14

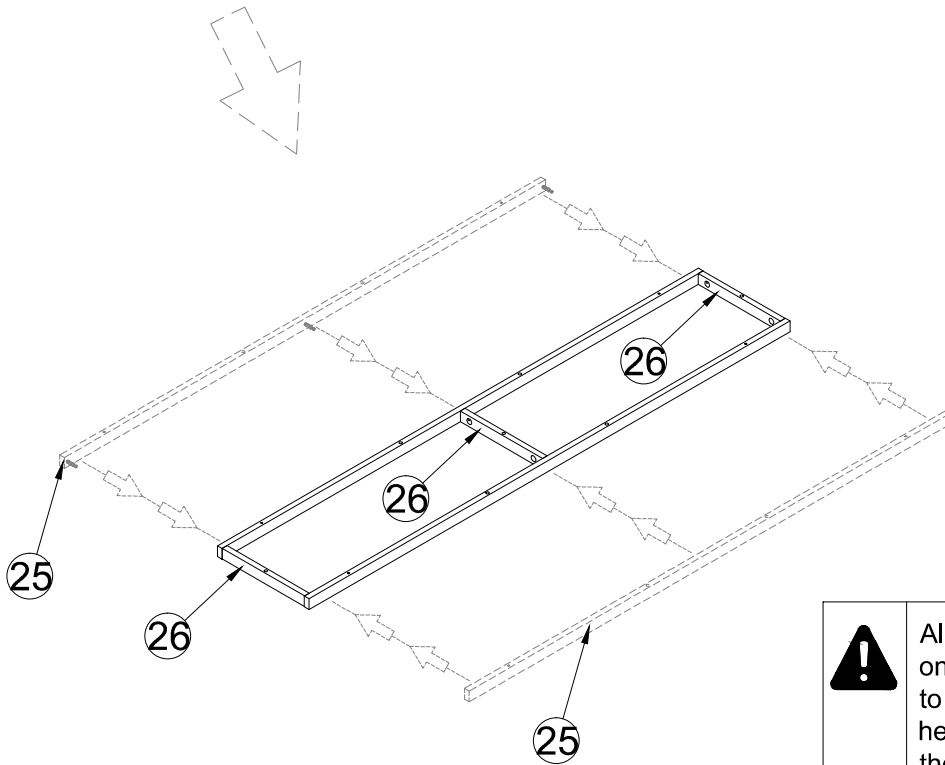
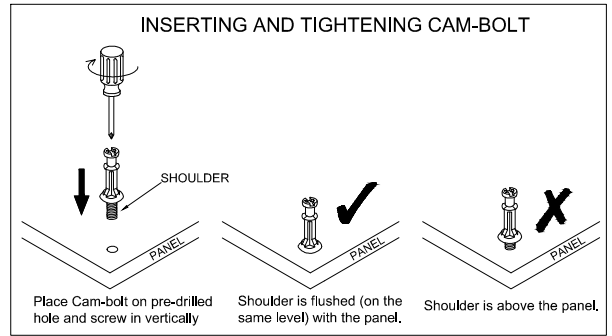
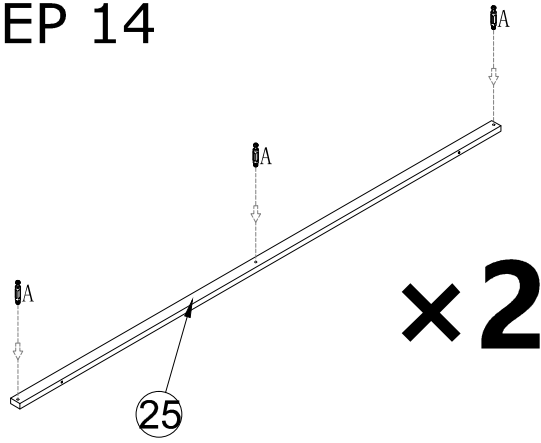

! Align the arrow on the Cam-lock to the Cam-bolt head and insert the Cam-lock. Ensure Cam-lock is fully inserted.

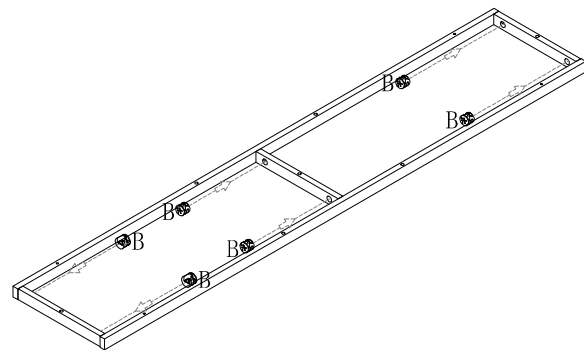
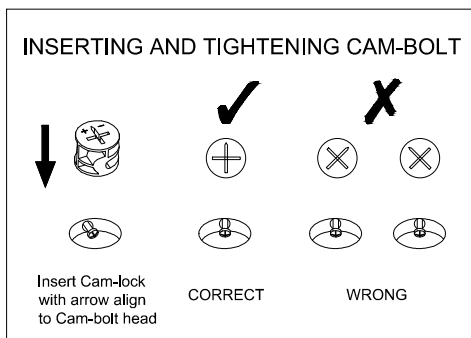

	A×6PCS
	B×6PCS

STEP 15

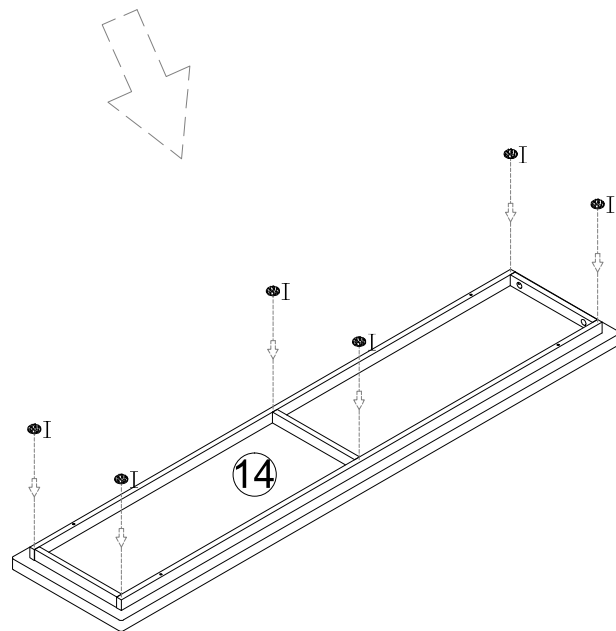
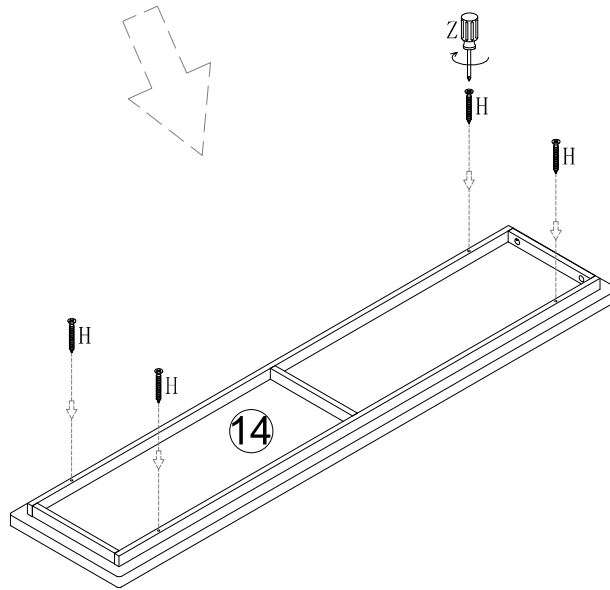
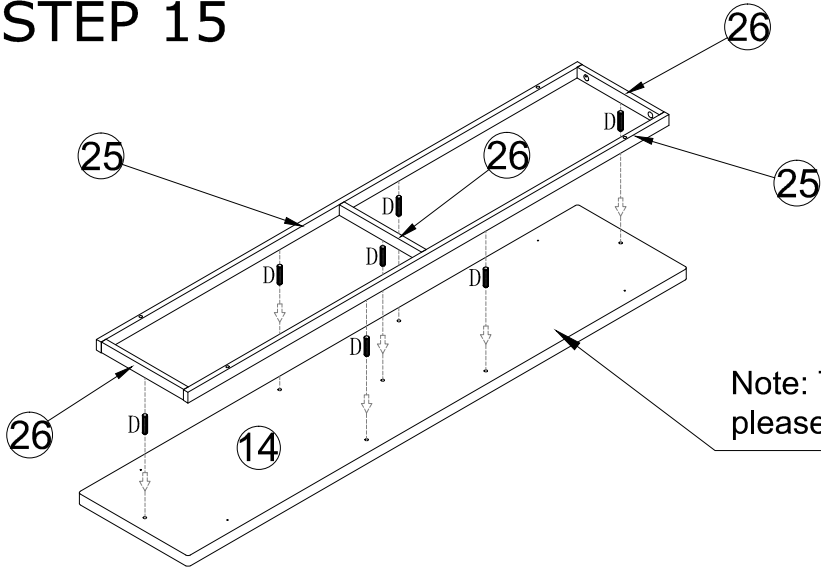

	D×7PCS
	H×4PCS
	I×6PCS

STEP 16

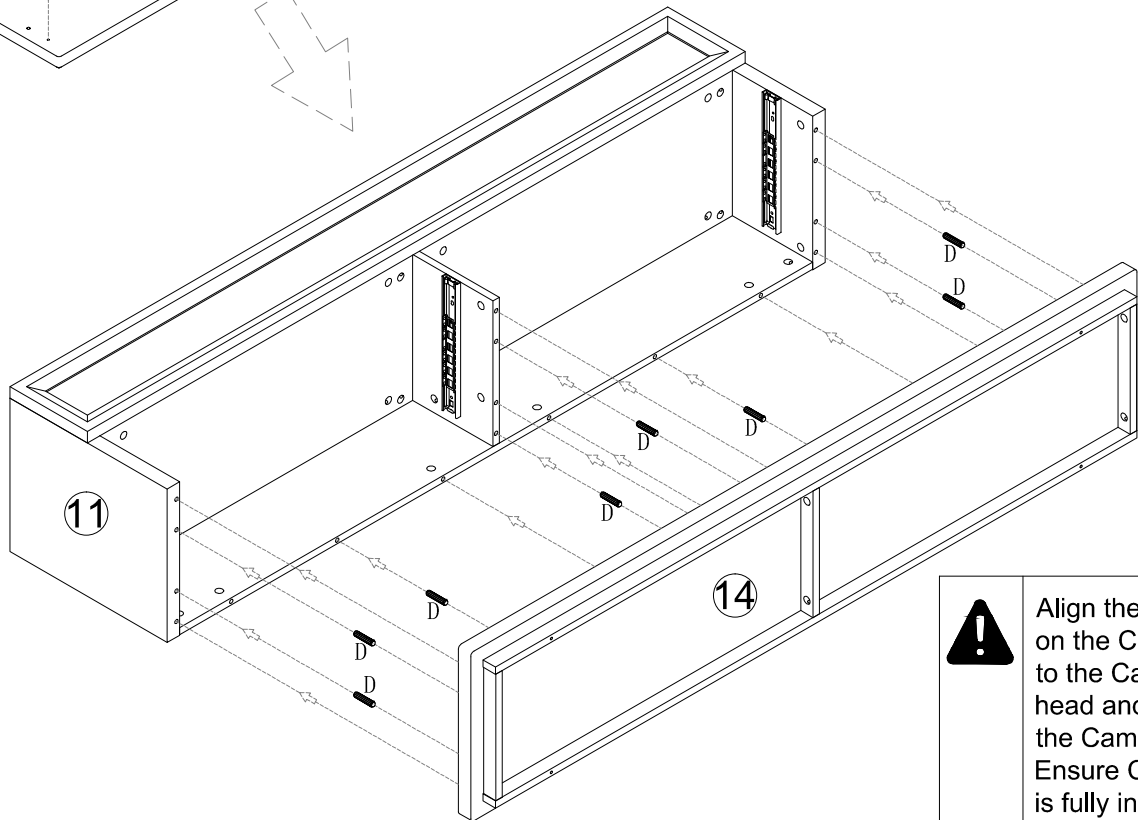
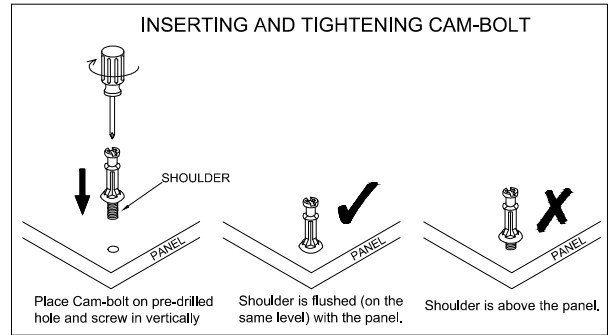
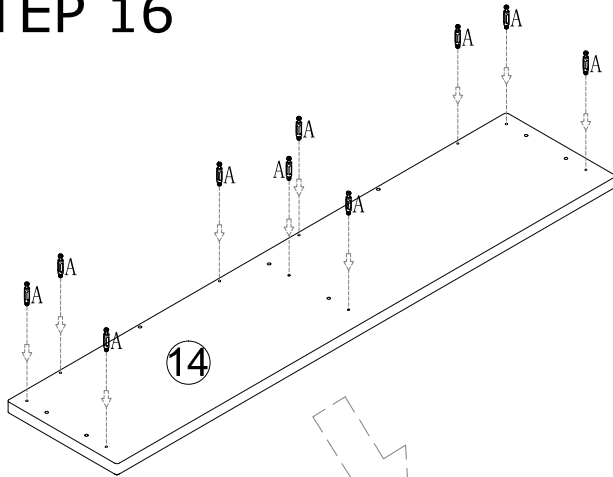

! Align the arrow on the Cam-lock to the Cam-bolt head and insert the Cam-lock. Ensure Cam-lock is fully inserted.

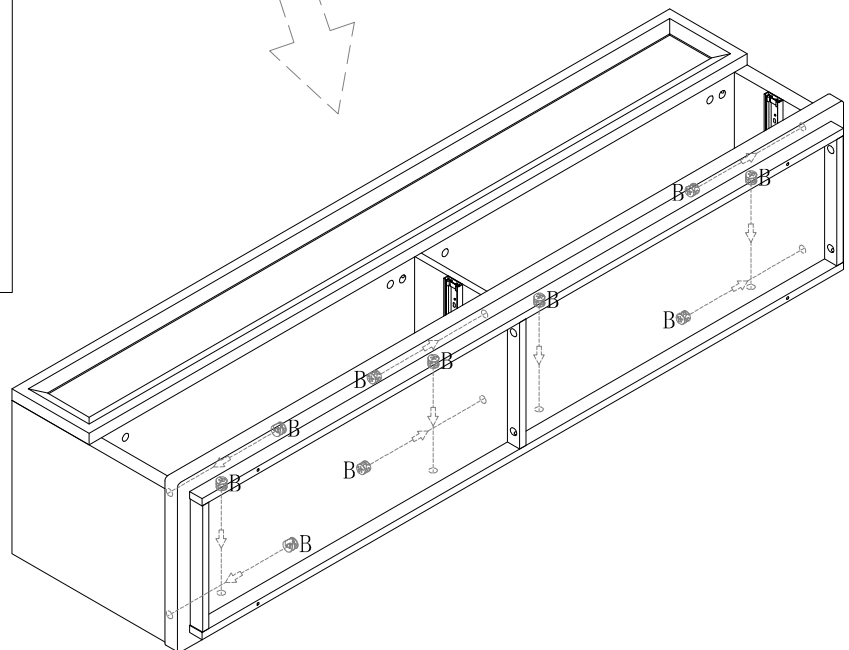
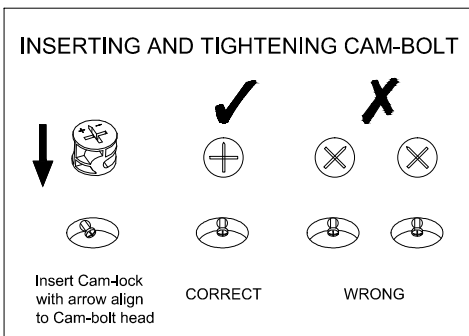

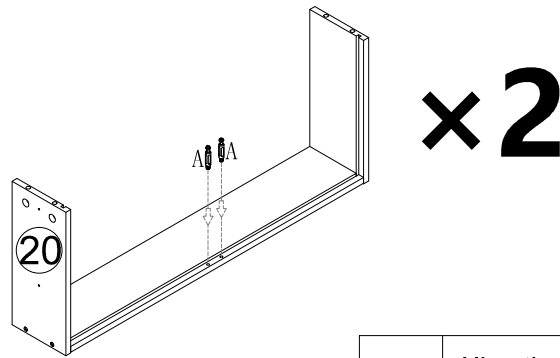
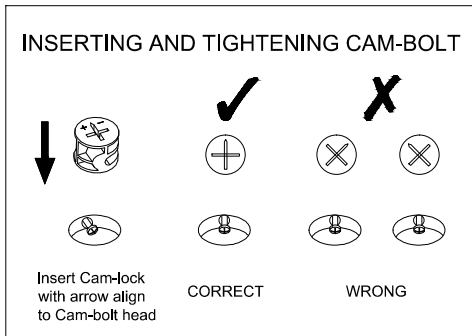
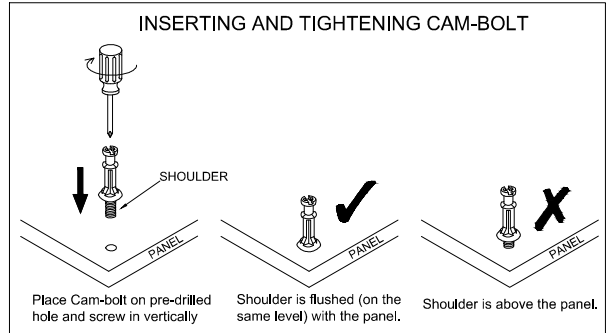
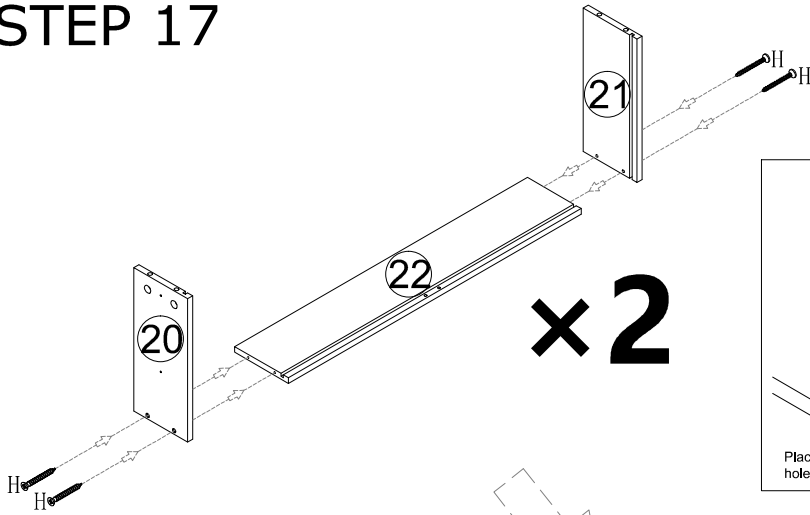

	A×10PCS
	B×10PCS
	D×8PCS

STEP 17

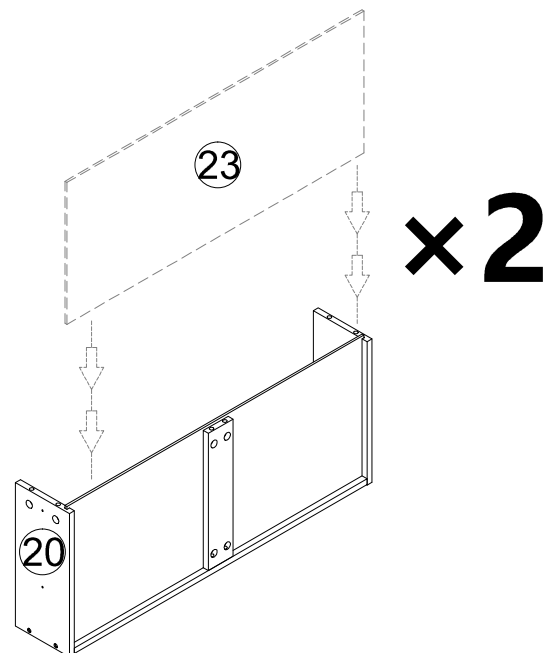
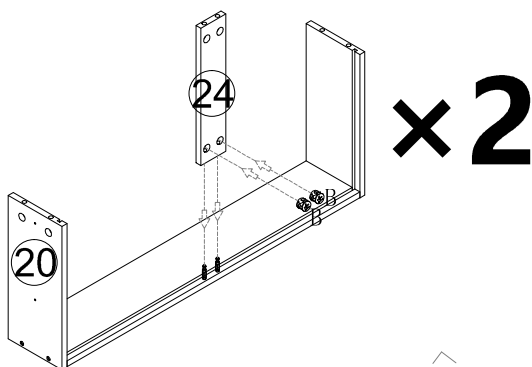

! Align the arrow on the Cam-lock to the Cam-bolt head and insert the Cam-lock. Ensure Cam-lock is fully inserted.

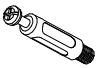

	A×4PCS
	B×4PCS
	H×8PCS

STEP 18

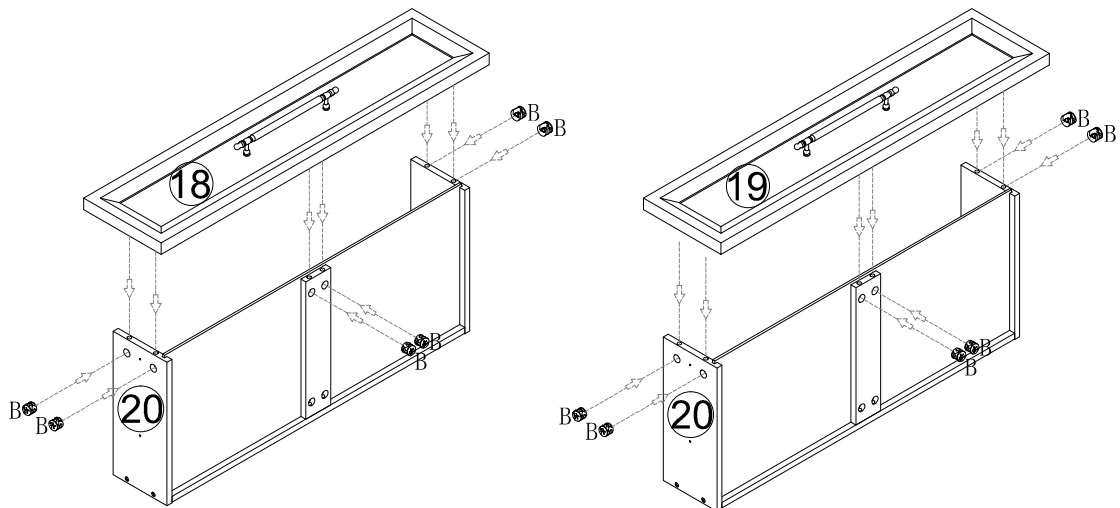
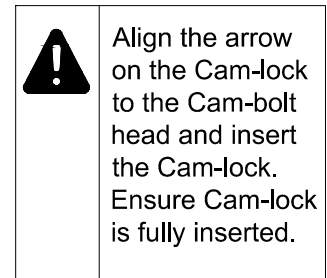
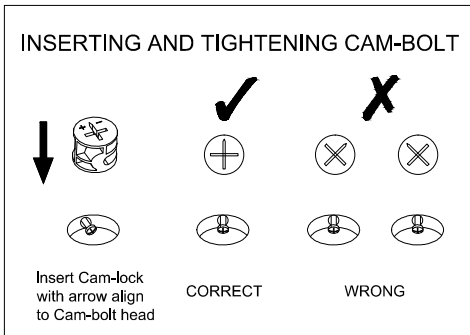
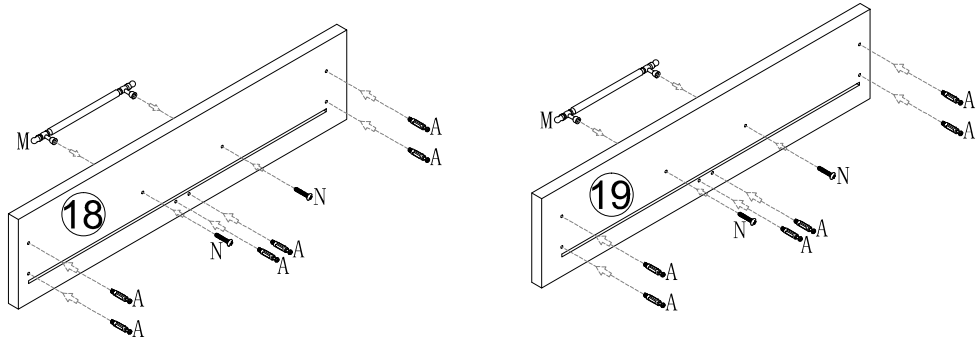
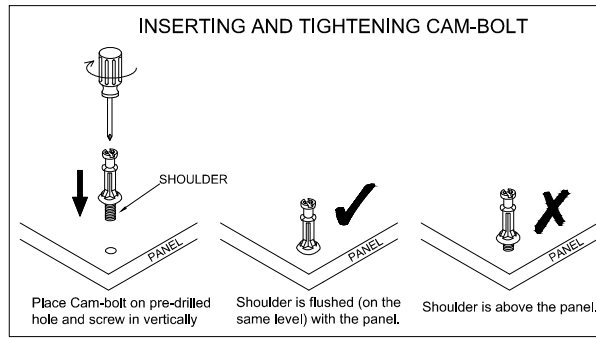

	A×12PCS
	B×12PCS
	M×2PCS
	N×4PCS

STEP 19

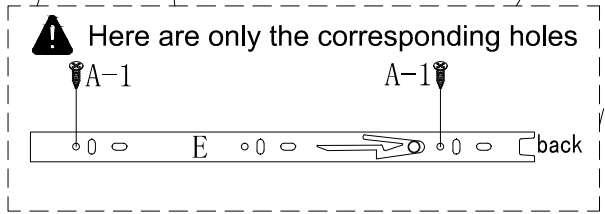
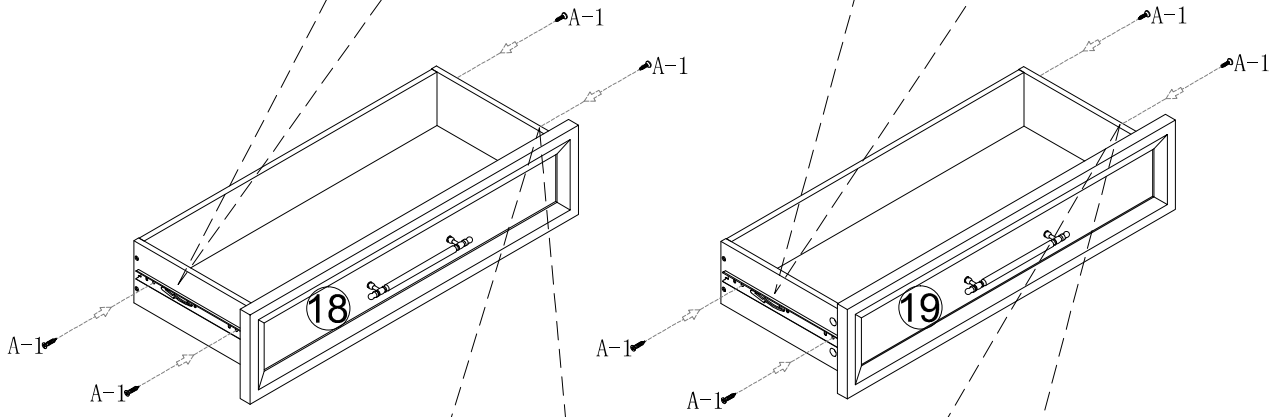
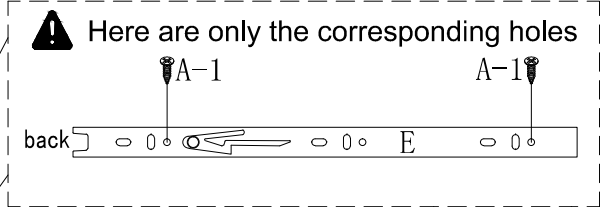

STEP 20

Drawer Front Alignment

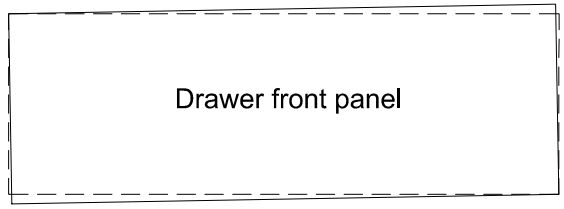

If the drawer front panel is NOT level after being assembled, then...

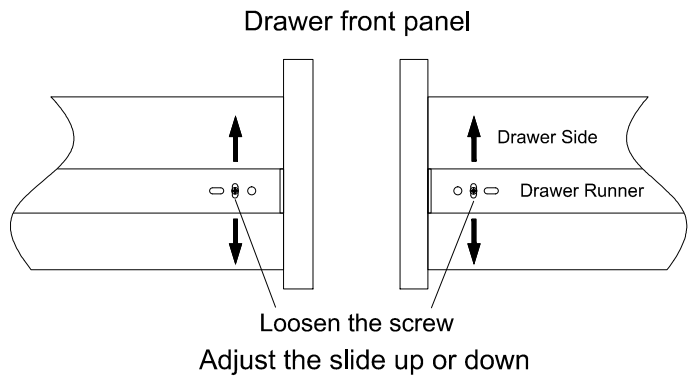

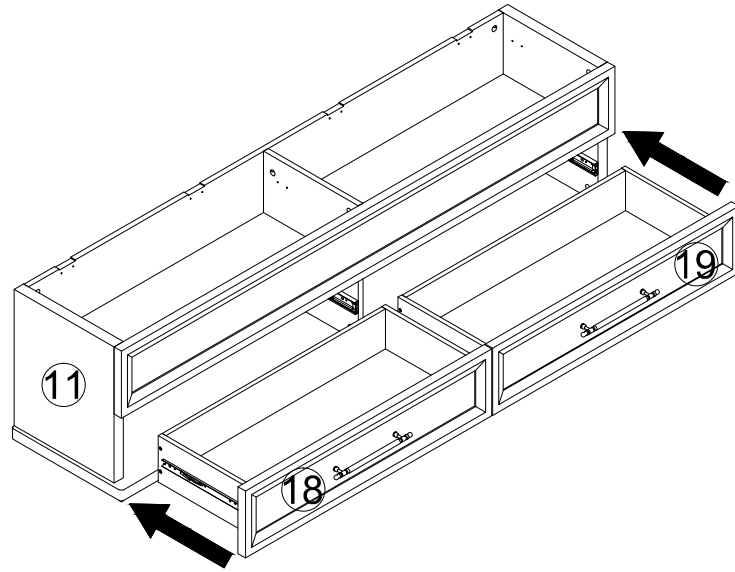

Loosen the screws on the left and right hand side, then adjust the drawer slide up or down, until the drawer fronts are even/level, then tighten the screws.

STEP 21

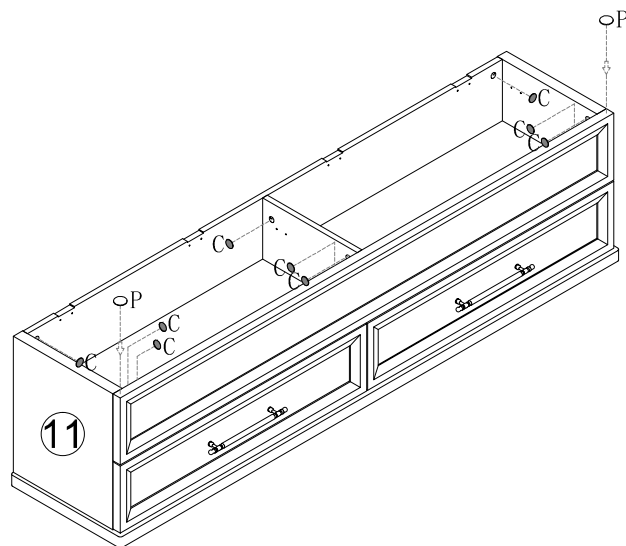

STEP 22



	C×9PCS
	P×2PCS

STEP 23

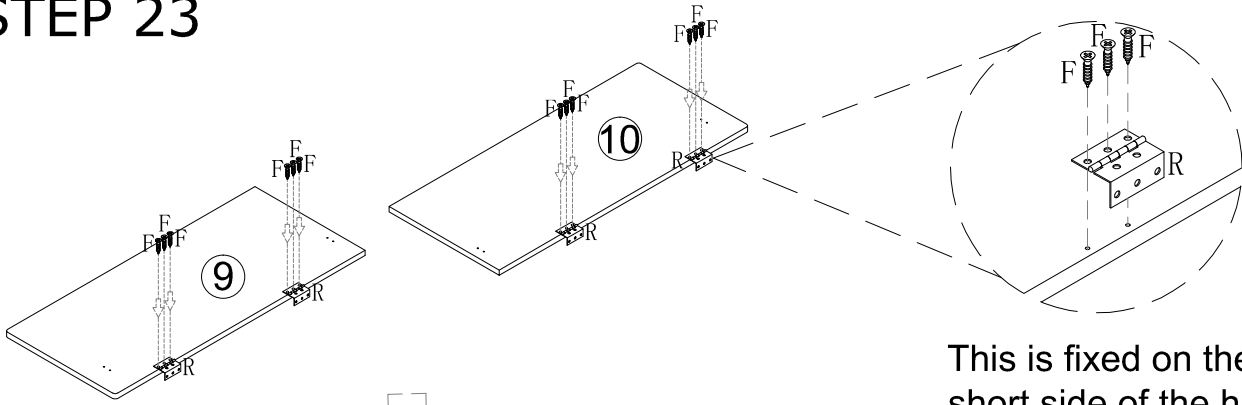

This is fixed on the short side of the hinge.

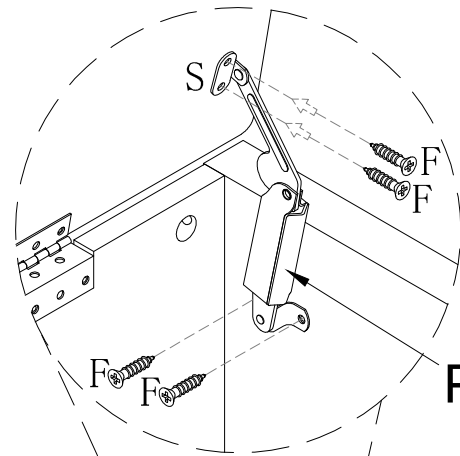
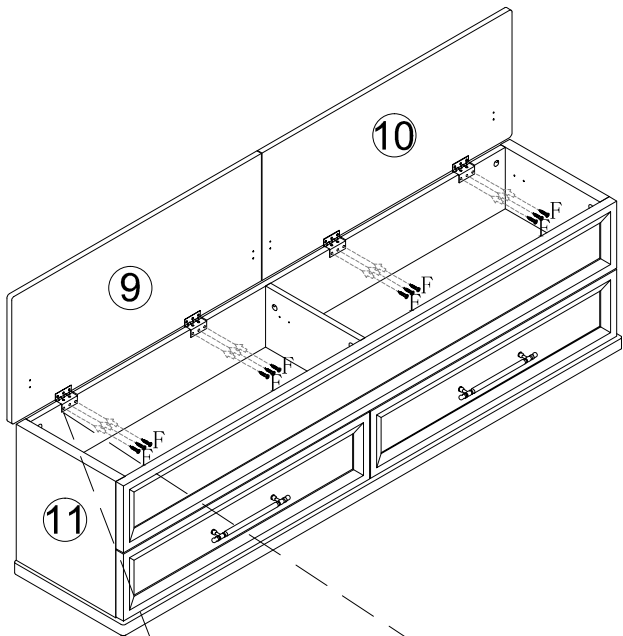

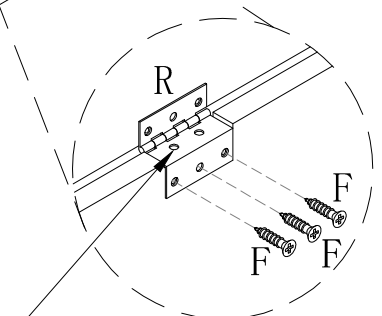

Right

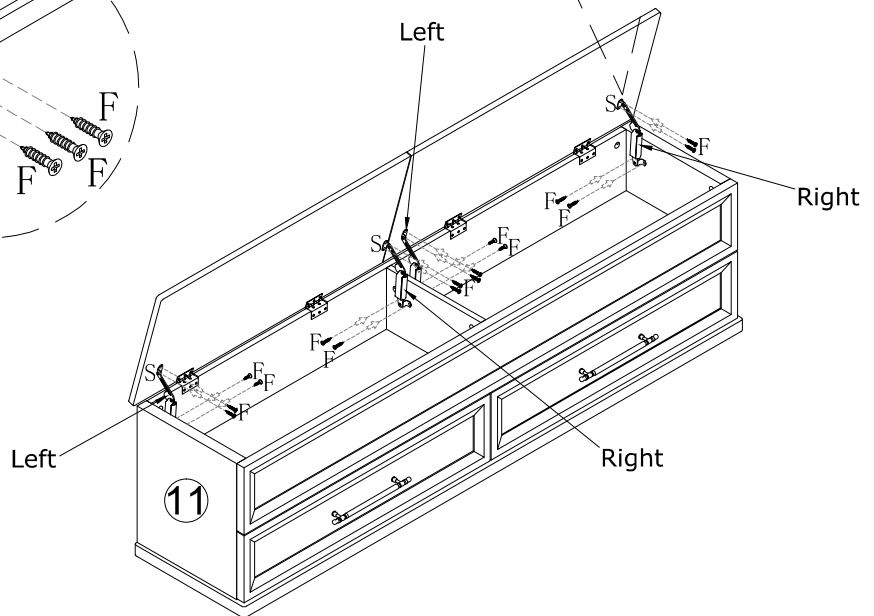

Note: The two holes above must not be secured with screws, otherwise it will cause the panel to be unable to close.



	F×40PCS
	R×4PCS
	S×2Sets

STEP 24



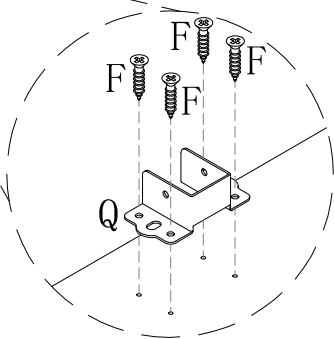
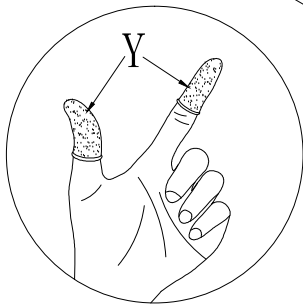
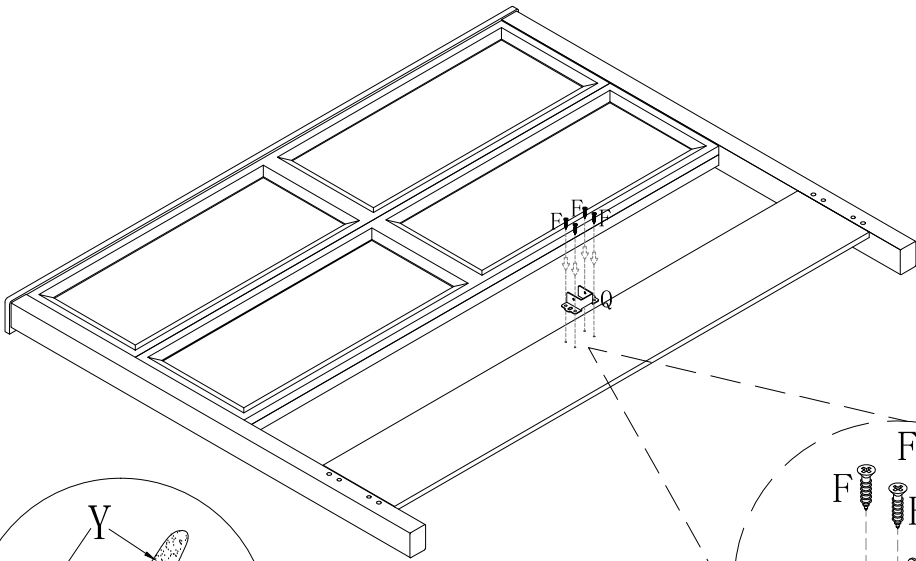

 **Reminder: The bed frame is heavy. From this step on, please place the accessories in the area where the bed will eventually be placed, and then proceed with subsequent assembly operations.**

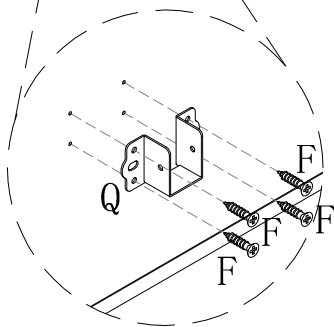
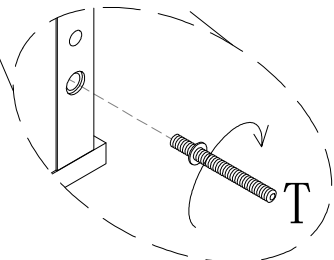
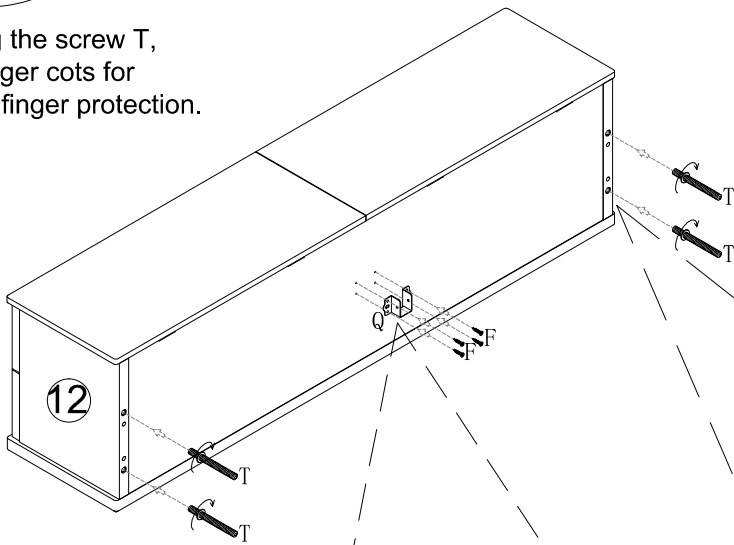

When installing the screw T, please wear finger cots for better grip and finger protection.



Note: Screw the shorter end of the screw into the board.

	F×8PCS
	Q×2PCS
	T×4PCS
	Y×4PCS

STEP 25

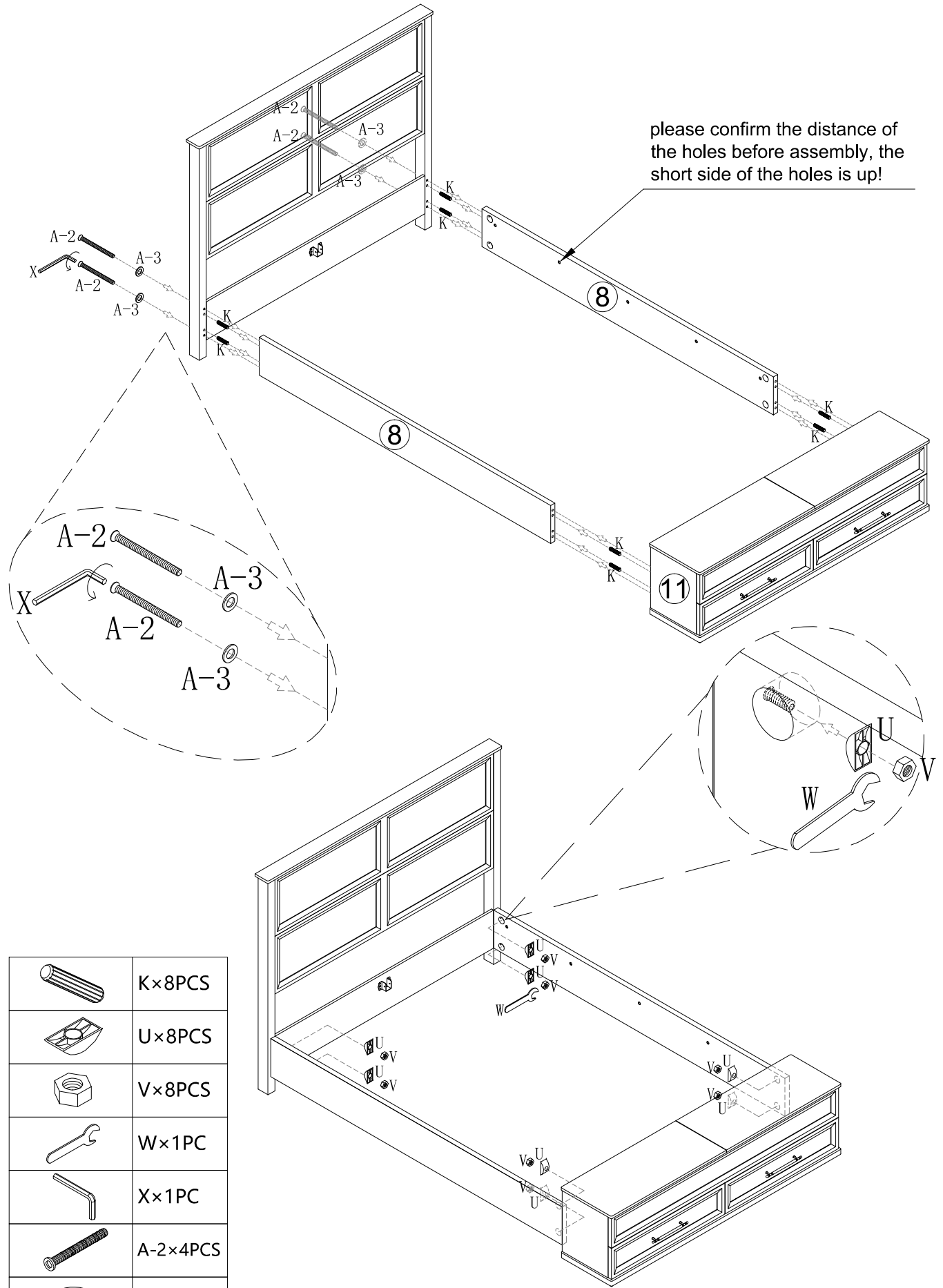

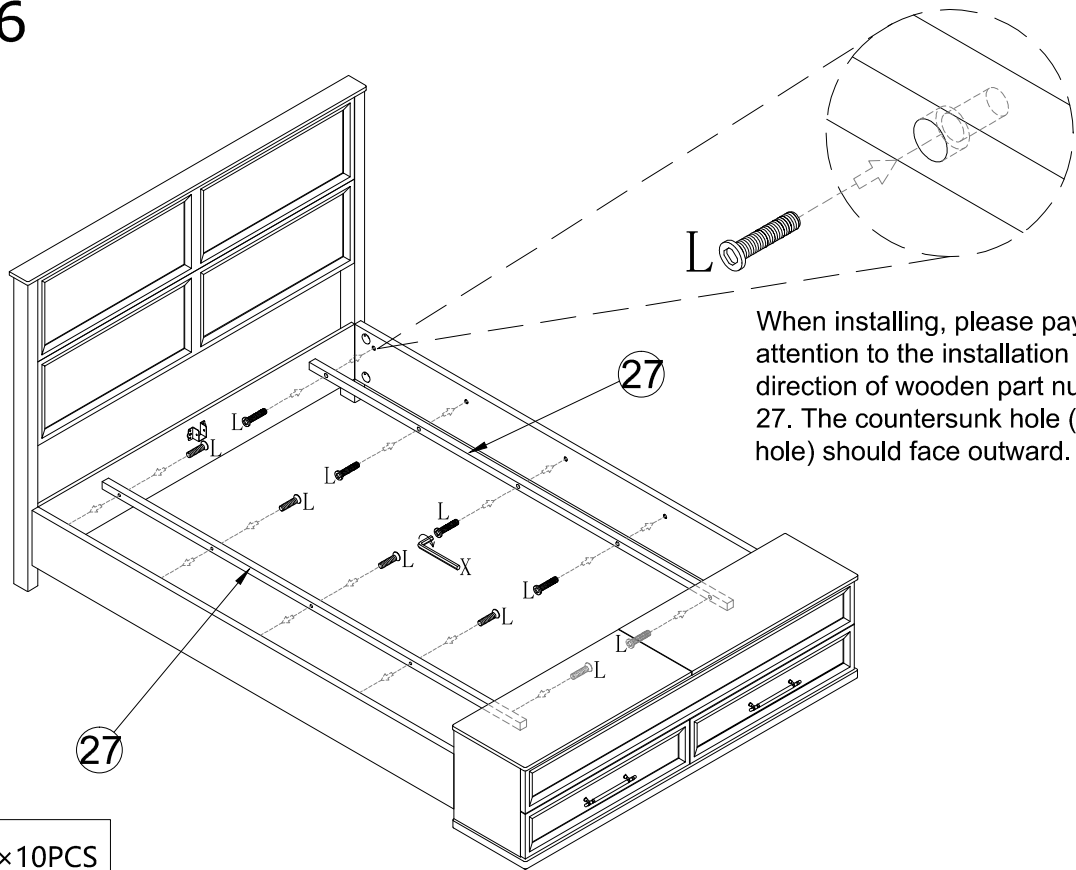

	K×8PCS
	U×8PCS
	V×8PCS
	W×1PC
	X×1PC
	A-2×4PCS
	A-3×4PCS

STEP 26



When installing, please pay attention to the installation direction of wooden part number 27. The countersunk hole (large hole) should face outward.

	L×10PCS
	X×1PC

STEP 27

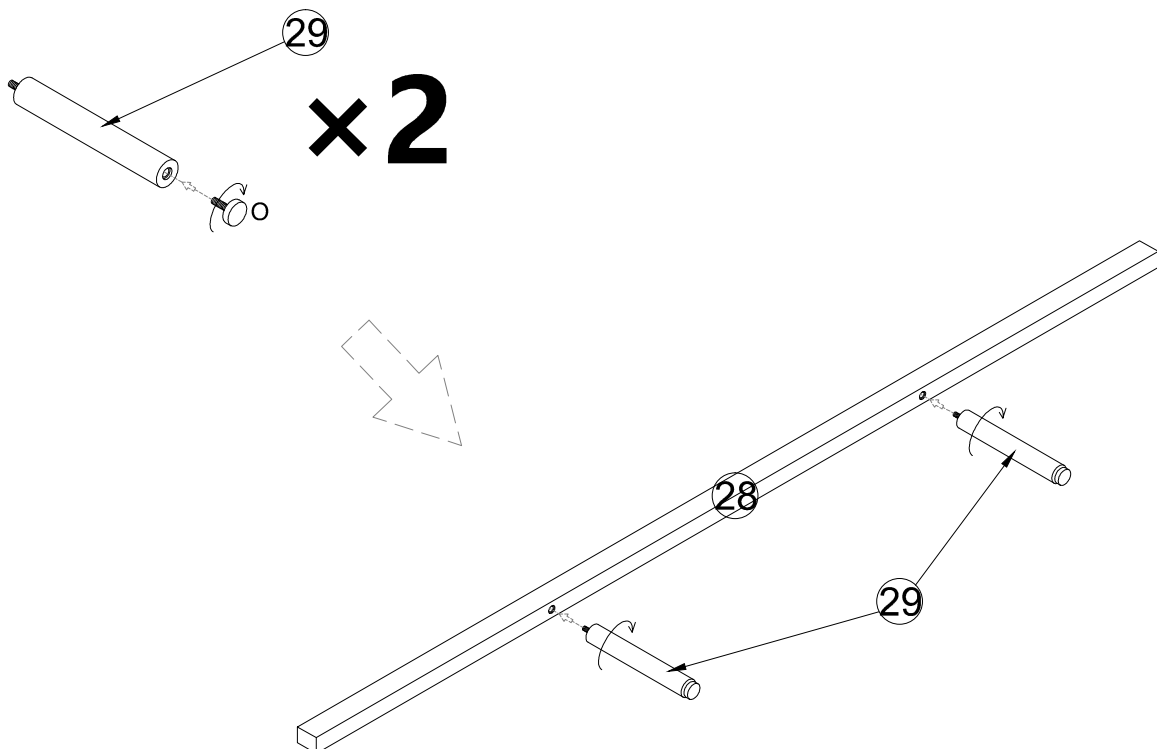

	O×2PCS
---	--------

STEP 28

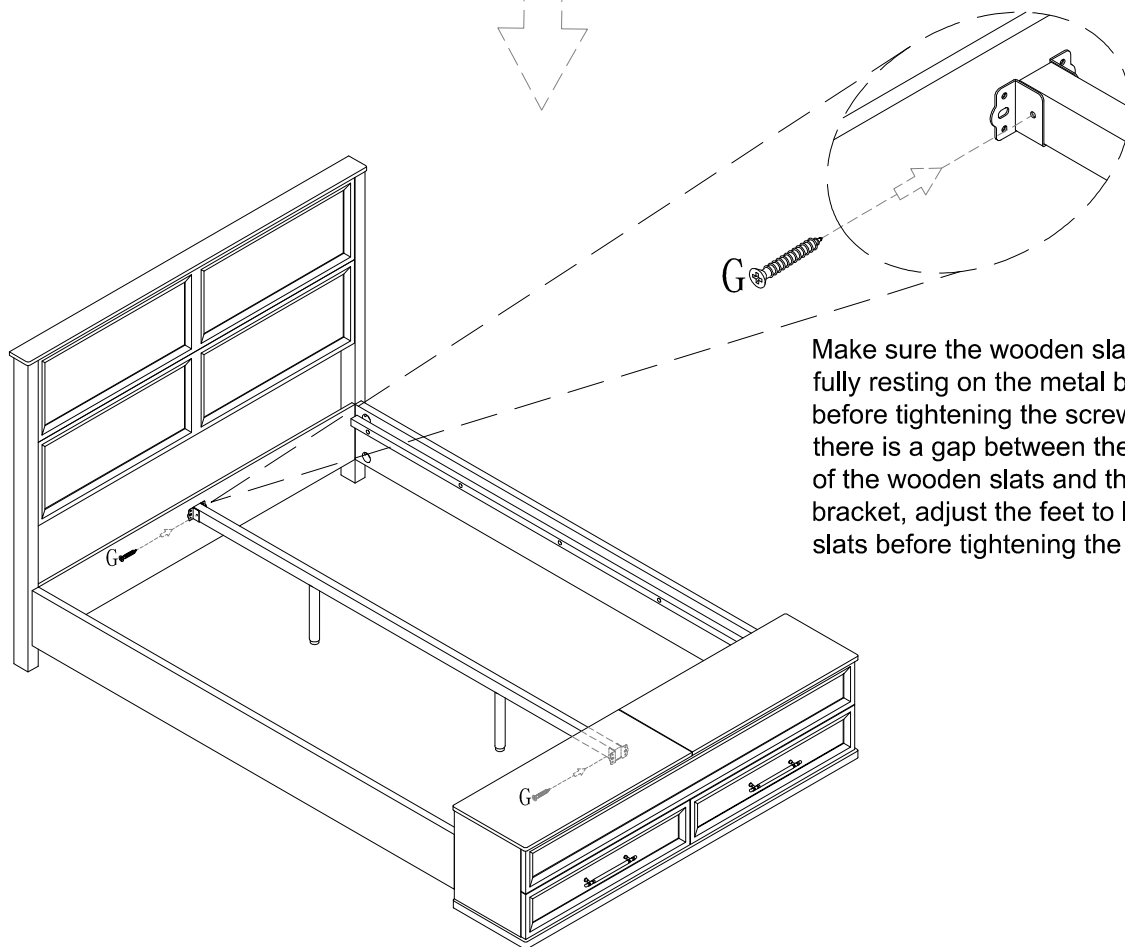
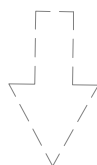
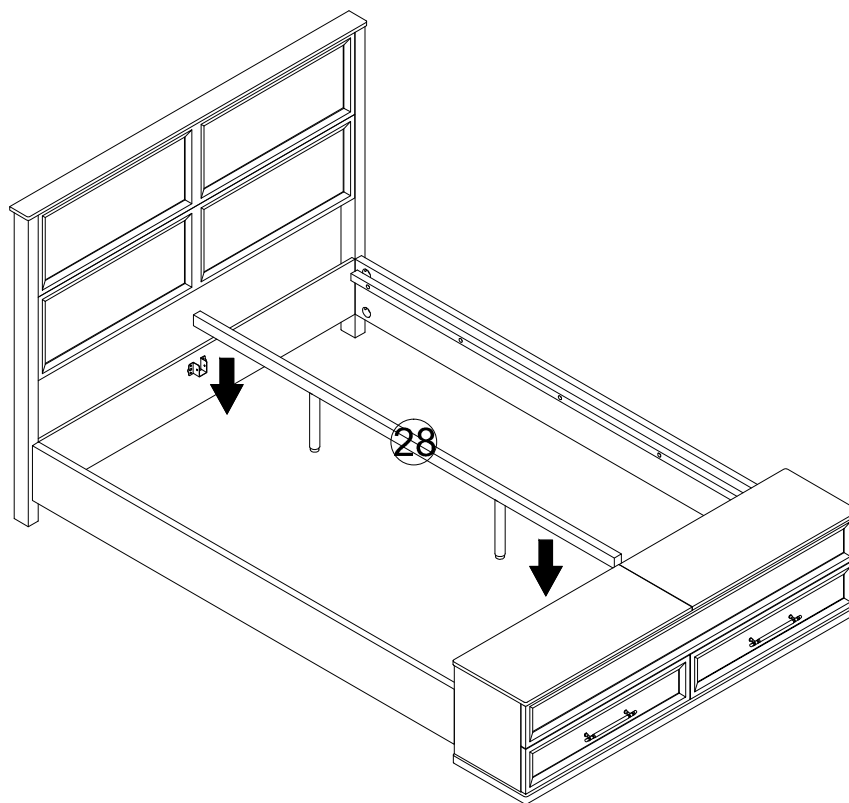

Make sure the wooden slats are fully resting on the metal bracket before tightening the screws. If there is a gap between the bottom of the wooden slats and the metal bracket, adjust the feet to lower the slats before tightening the screws.



G×2PCS

STEP 29

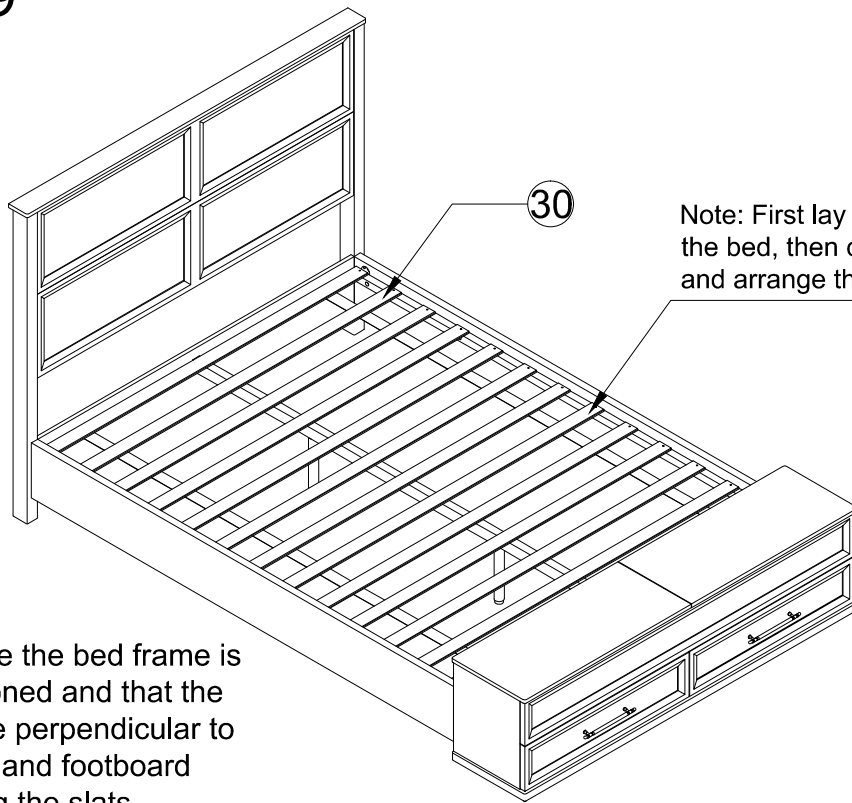

First, make sure the bed frame is properly positioned and that the side frames are perpendicular to the headboard and footboard before installing the slats.

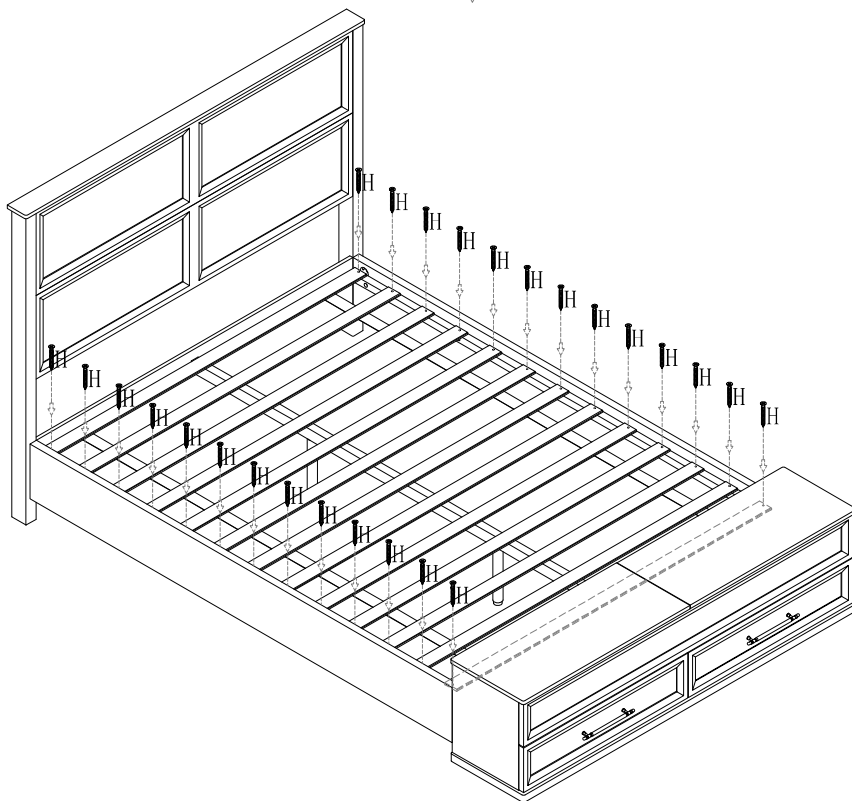
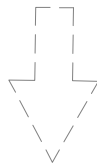

STEP 30

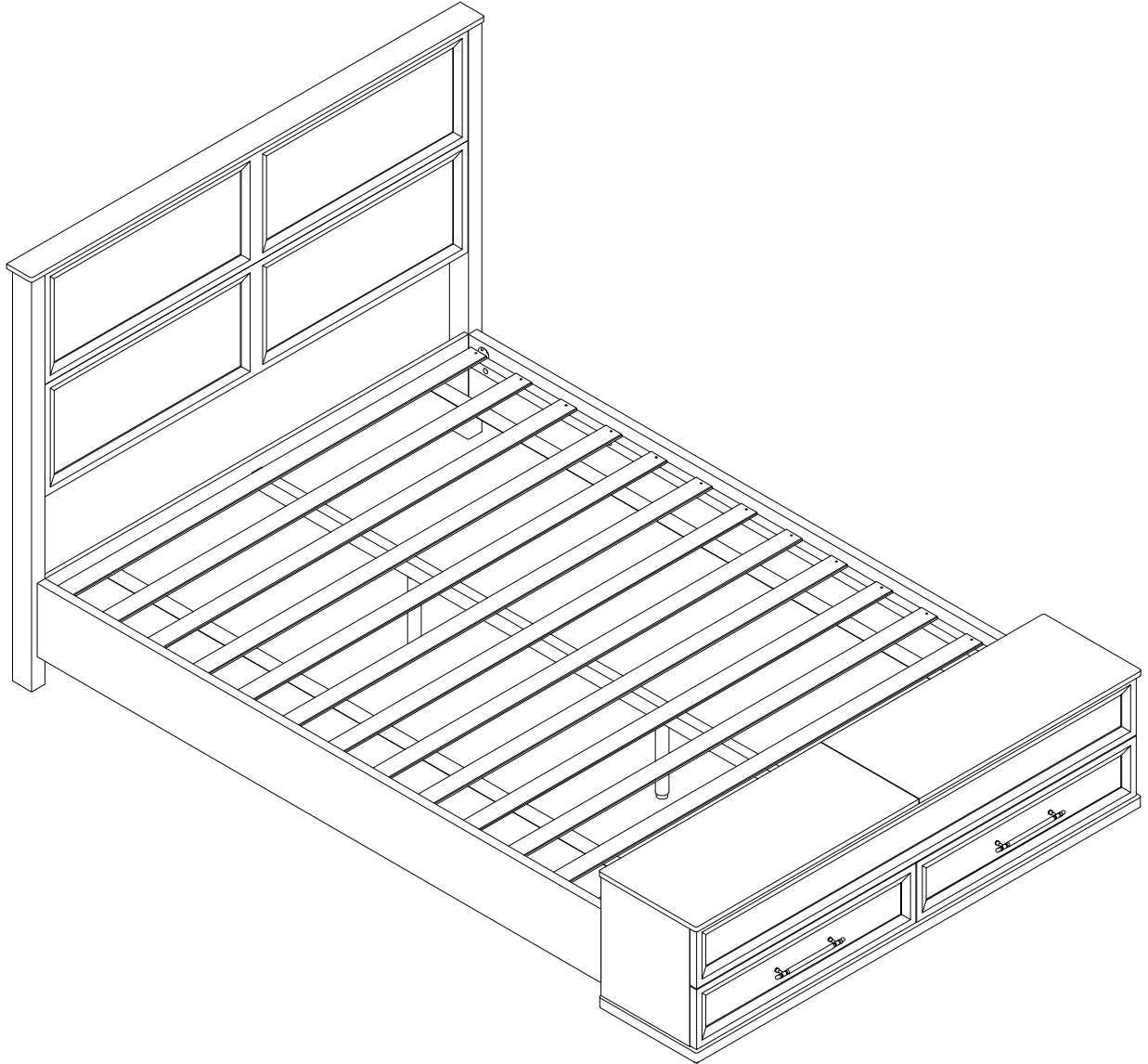

Assembly complete