

ASSEMBLY INSTRUCTIONS

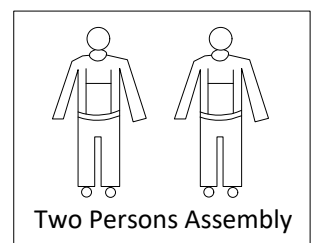

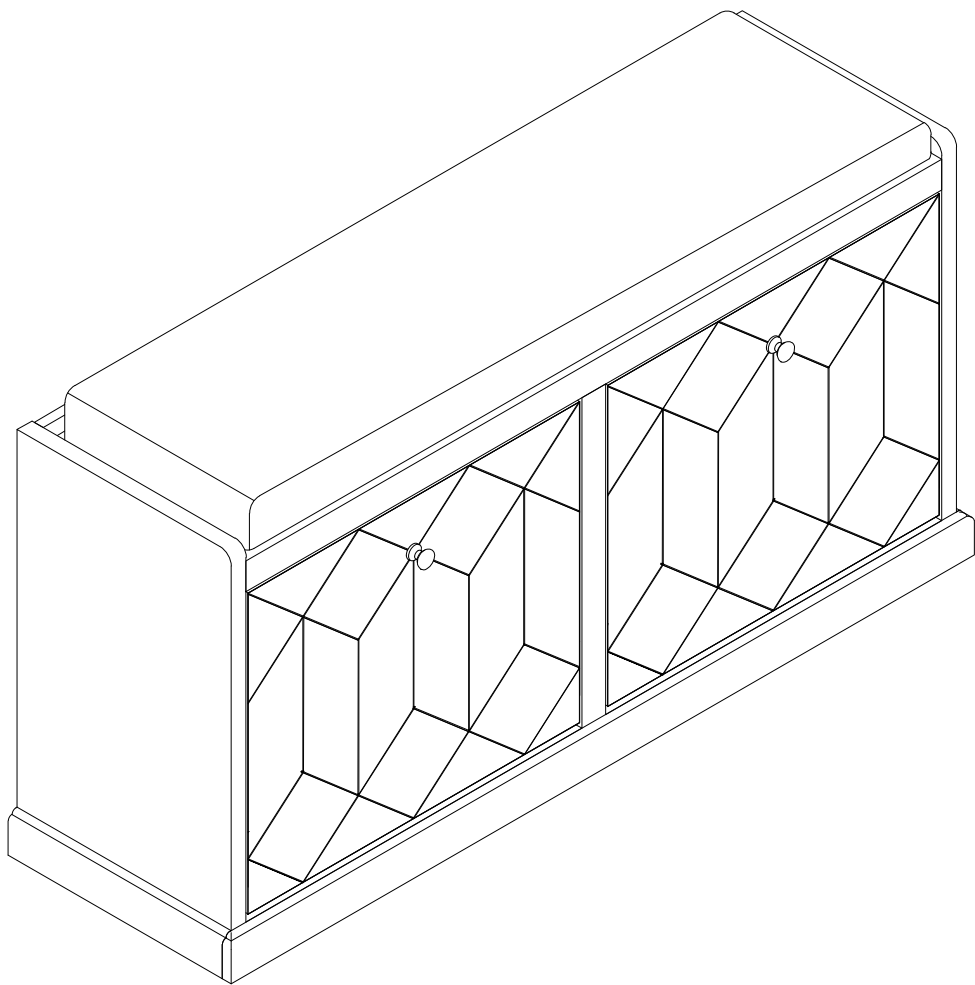

ASSEMBLY TOOLS REQUIRED (NOT INCLUDED)

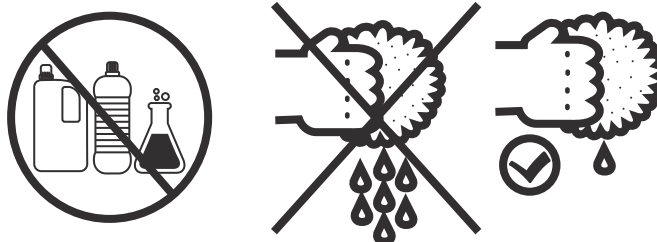
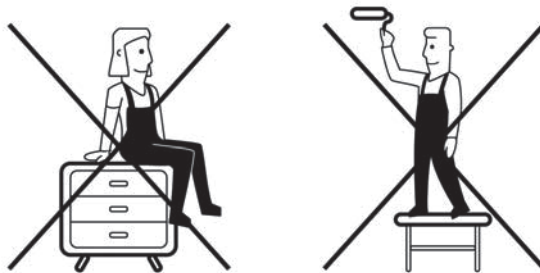
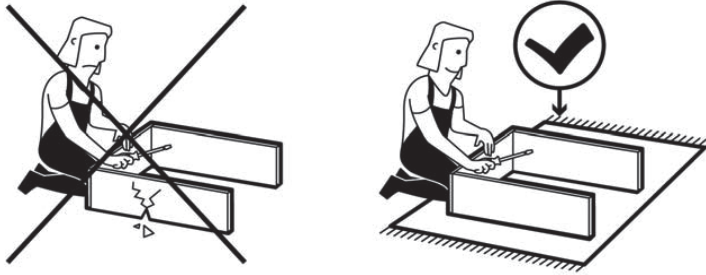
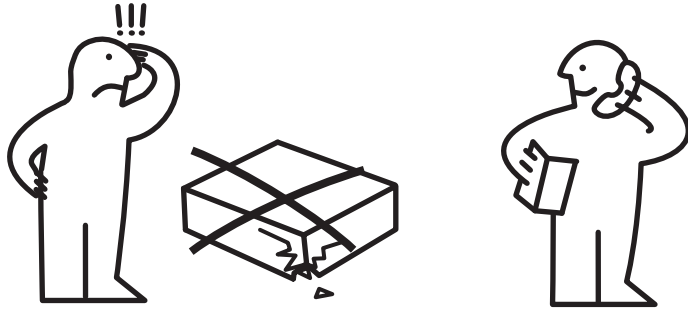
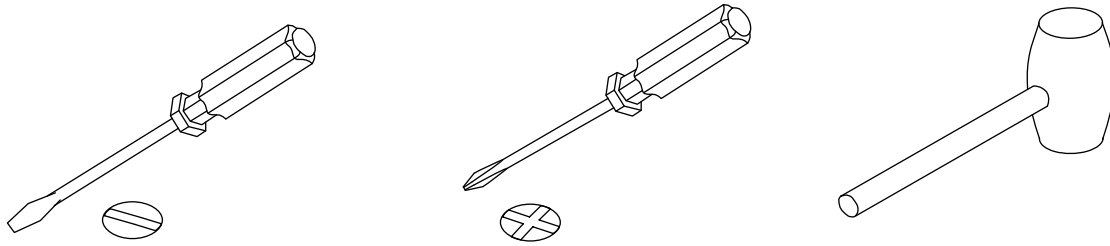

- * Before discarding packing materials, please check all parts and hardware are presented.
- * Please follow the instructions closely.
- * After few days of initial assembly, the product may have acclimated to new environment, please tighten all hardware again.

Dowel Installation

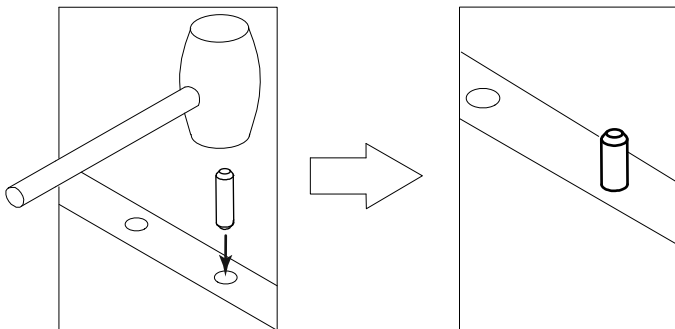

Gently tap dowel into hole with rubber mallet.

CAM-LOCK

Tighten until shoulder is flush with panel. Do not overtighten or undertighten

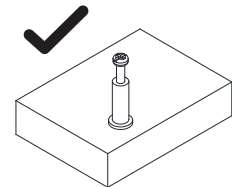
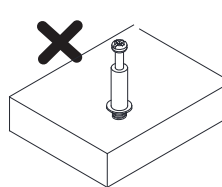
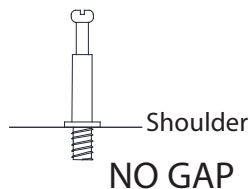

WHEN FITTING CAMS

ENSURE STARTING POSITION IS CORRECT BEFORE YOU INSERT CONNECTING CAM-PILLAR
TURN CLOCKWISE UNTIL SECURE

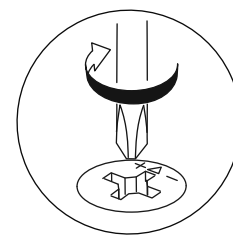
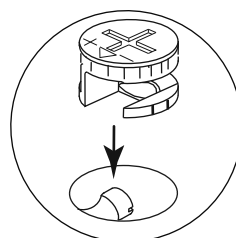
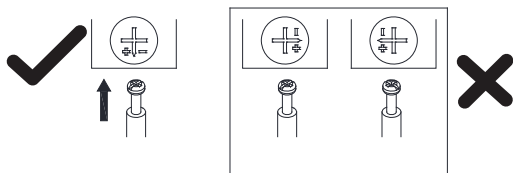

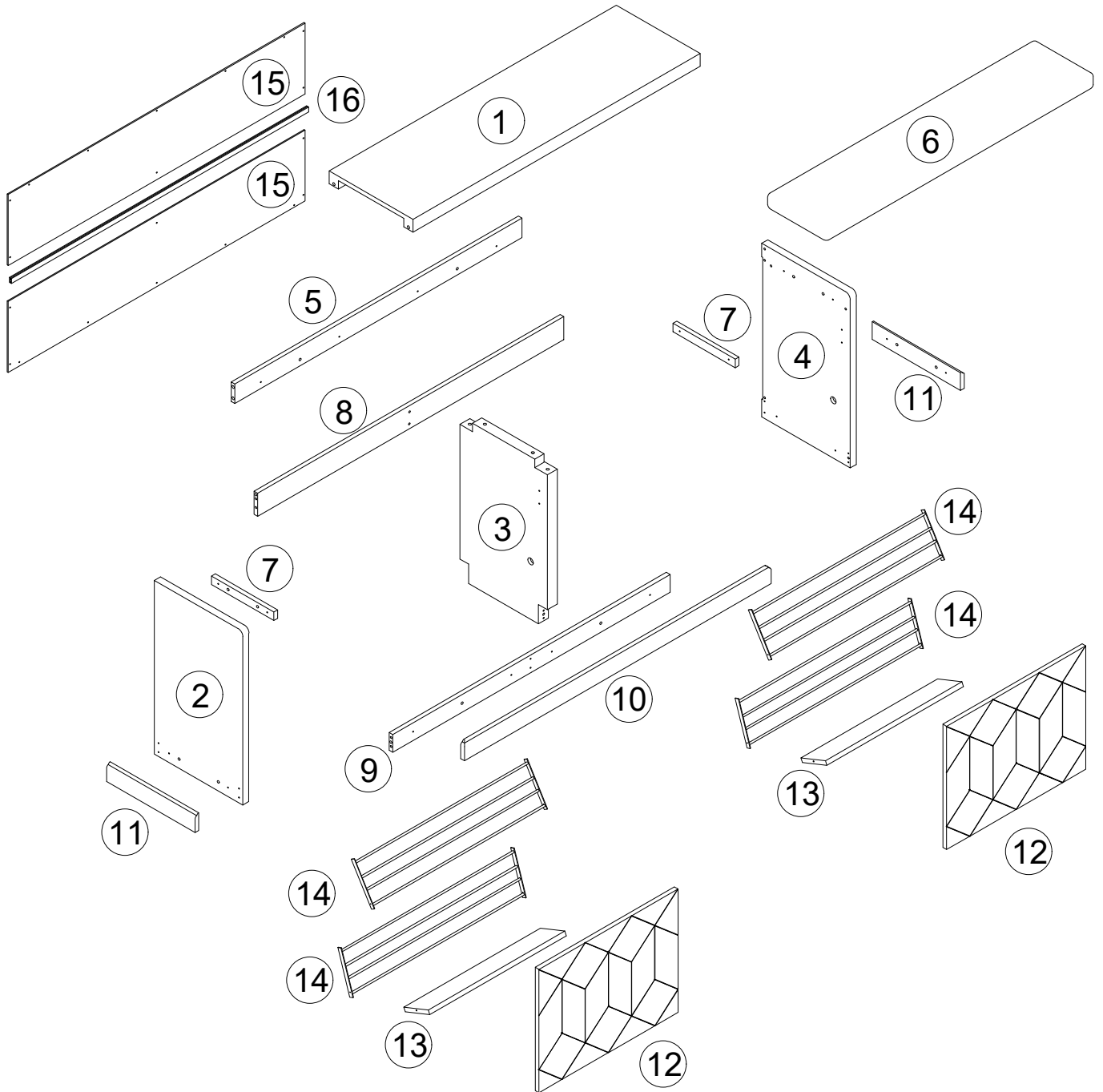

Laying out all the parts and hardware and identifying each part as shown below. It may help you when you assemble the item.

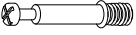

① × 1	② × 1	③ × 1	④ × 1	⑤ × 1	⑥ × 1
⑦ × 2	⑧ × 1	⑨ × 1	⑩ × 1	⑪ × 2	⑫ × 2
⑬ × 2	⑭ × 4	⑮ × 2	⑯ × 1		

A	×10+2(Spare)
	
Ø6×27mm	

B	×10+2(Spare)
	
Ø15×9.5mm	

C	×17+2(Spare)
	
Ø6×20mm	

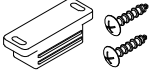
D	×4
	
45×15cm/FA3×16mm	

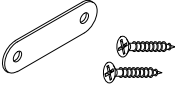
E	×4
	
45×15×1mm/FA3×12mm	

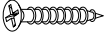
F	×16+2(Spare)
	
FA4×16mm	

G	×2
	

H	×2+1(Spare)
	
M4×10mm	

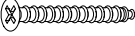
I	×20+2(Spare)
	
FA3.5×30mm	

J	×16+2(Spare)
	
FA3×12mm	

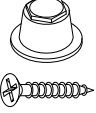
K	×4
	
FA4×16mm	

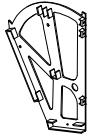
R	×2
	

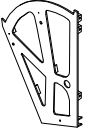
L	×2
	

N	×8+1(Spare)
	
M4×6mm	

O	×4+1(Spare)
	
FA4×30mm	

P	×4+1(Spare)
	
FA4×22mm	

1

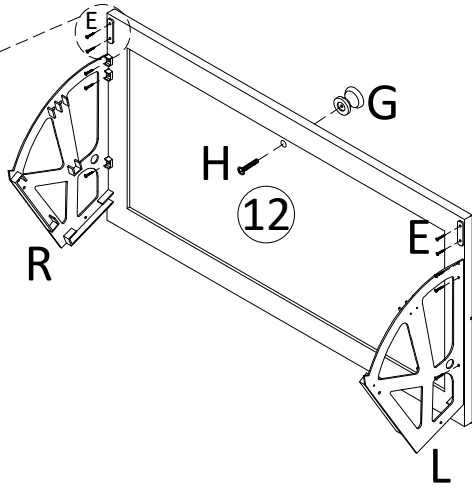
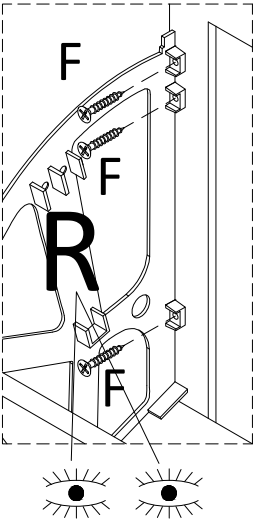
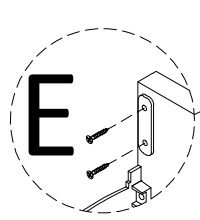

x2

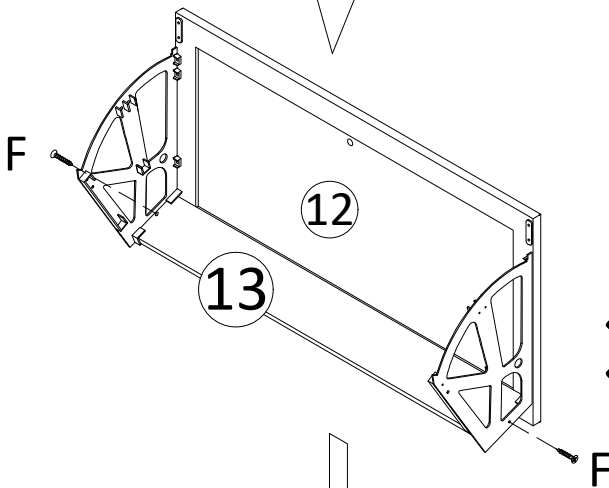
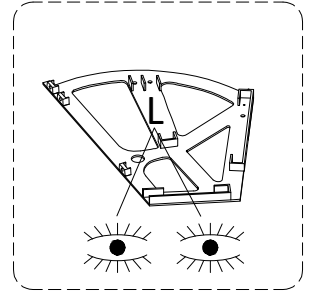
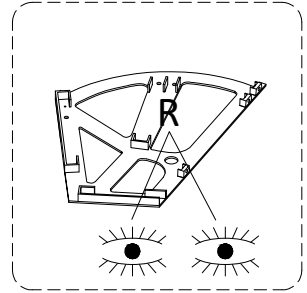

x2

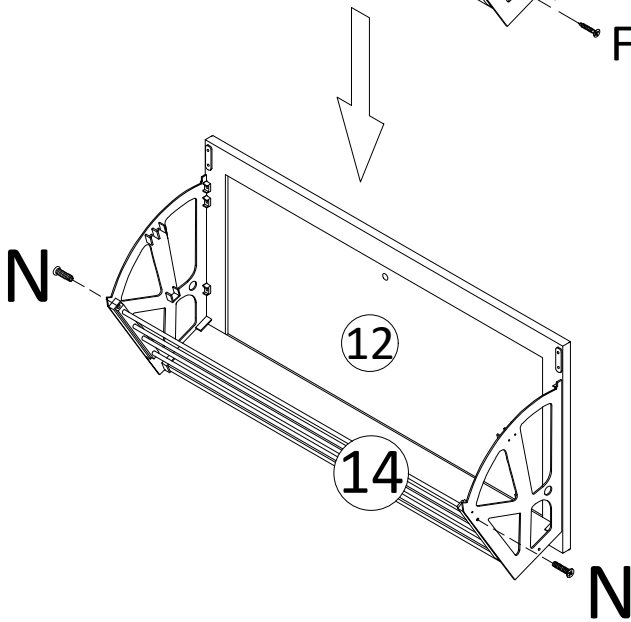

x2

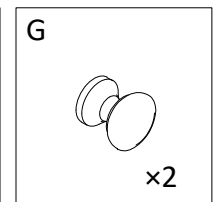
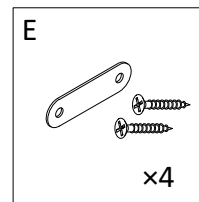
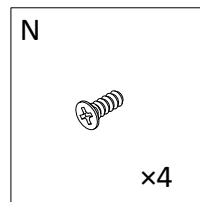
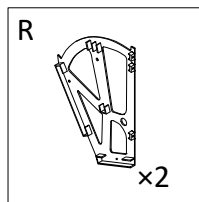
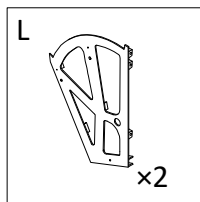
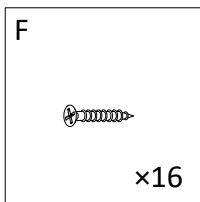
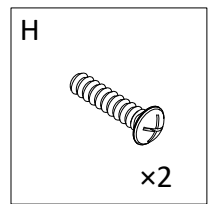

2

Turn the screws vertically from slow to fast.

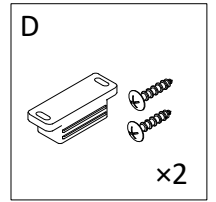
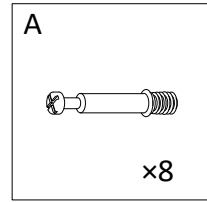
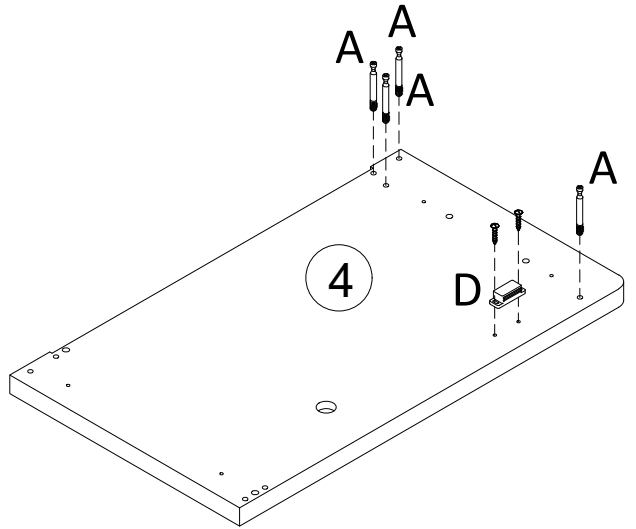
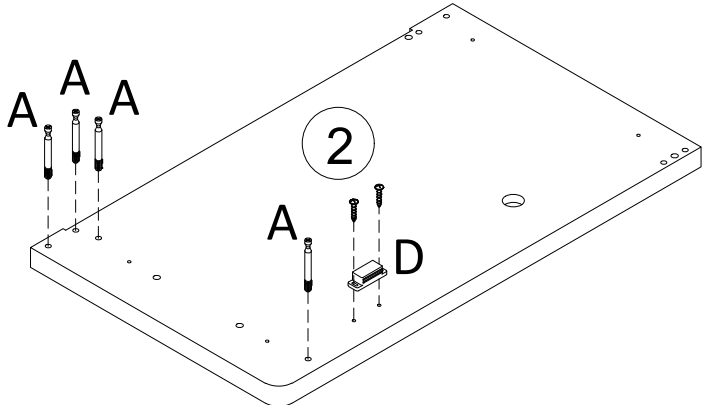

3

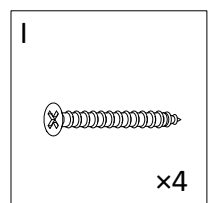
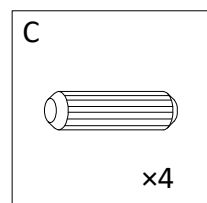
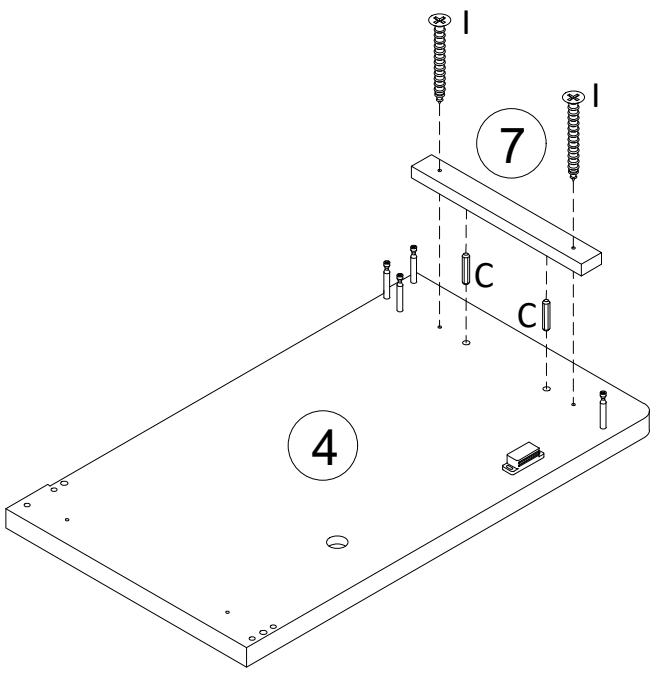
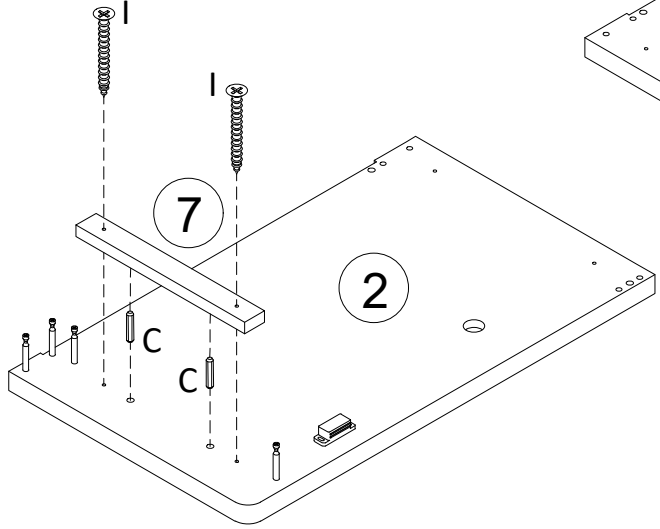

4

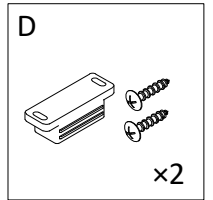
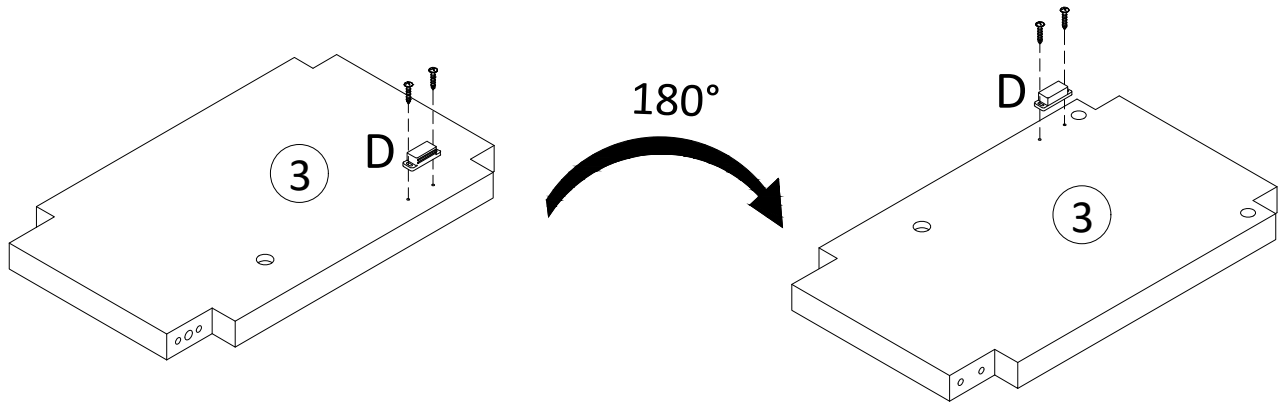

5

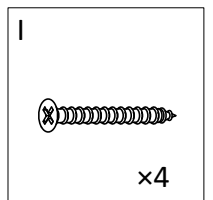
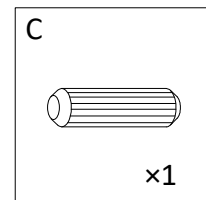
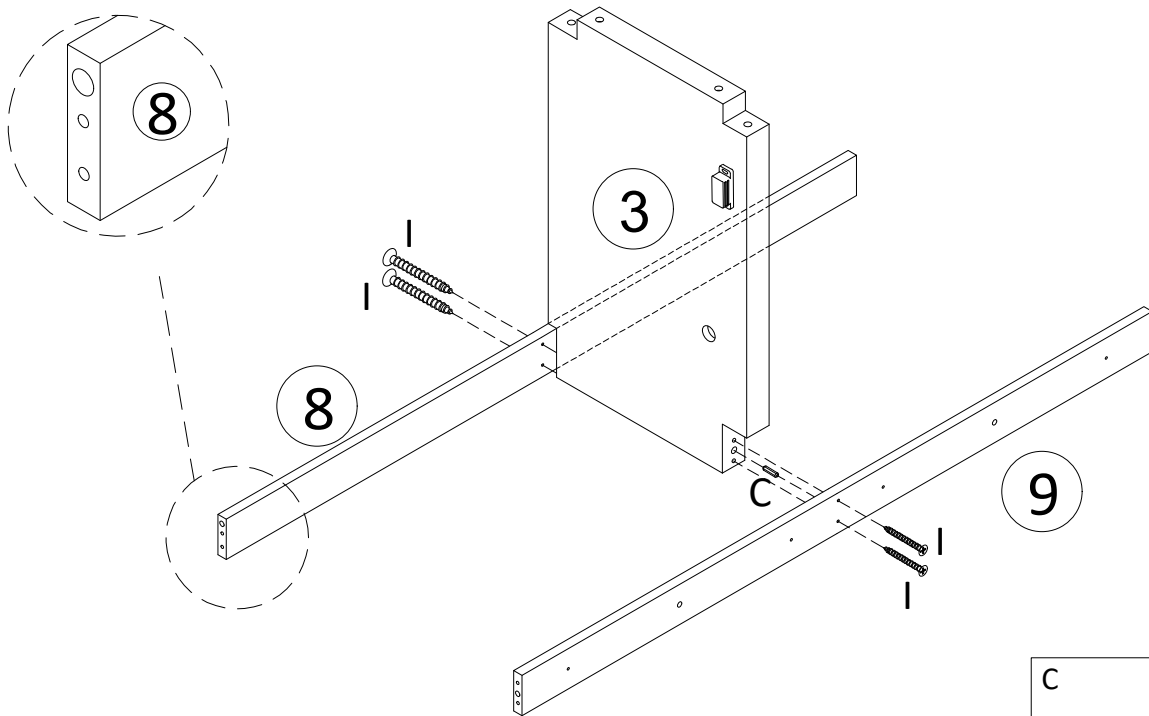

6

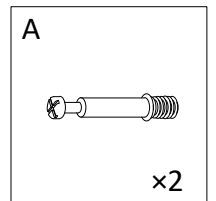
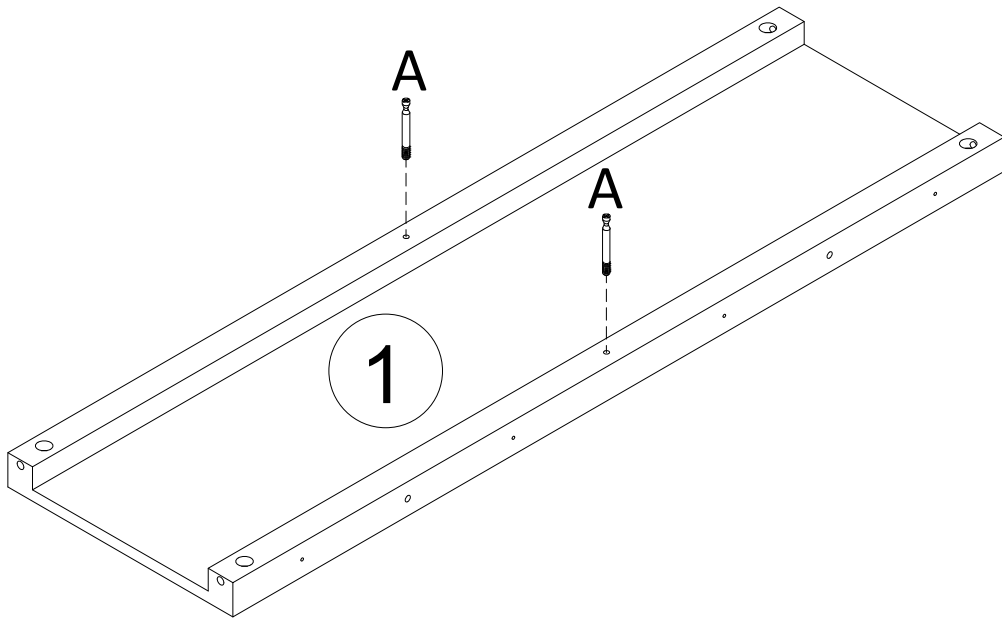

7

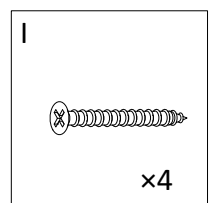
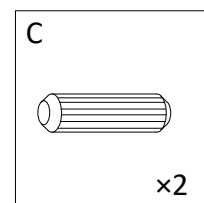
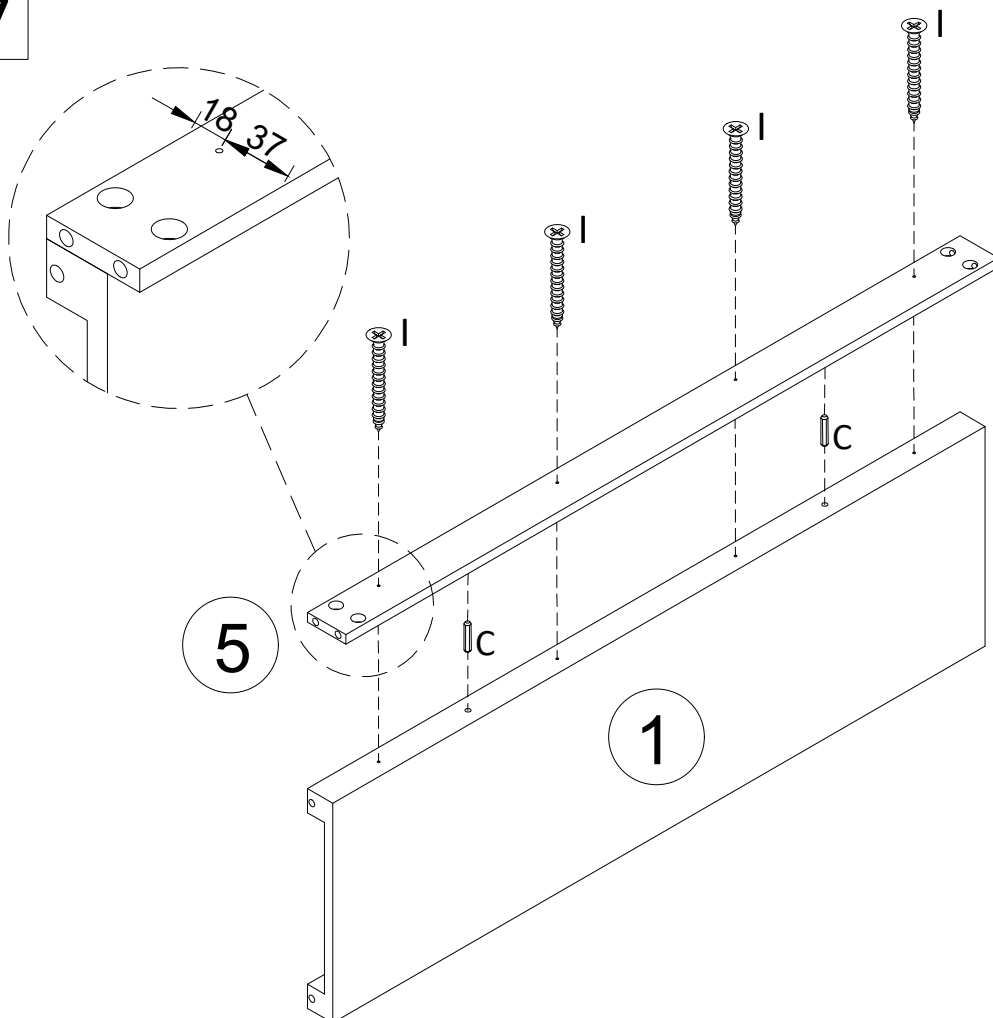

8

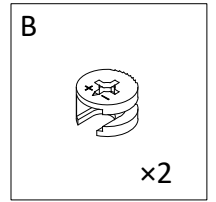
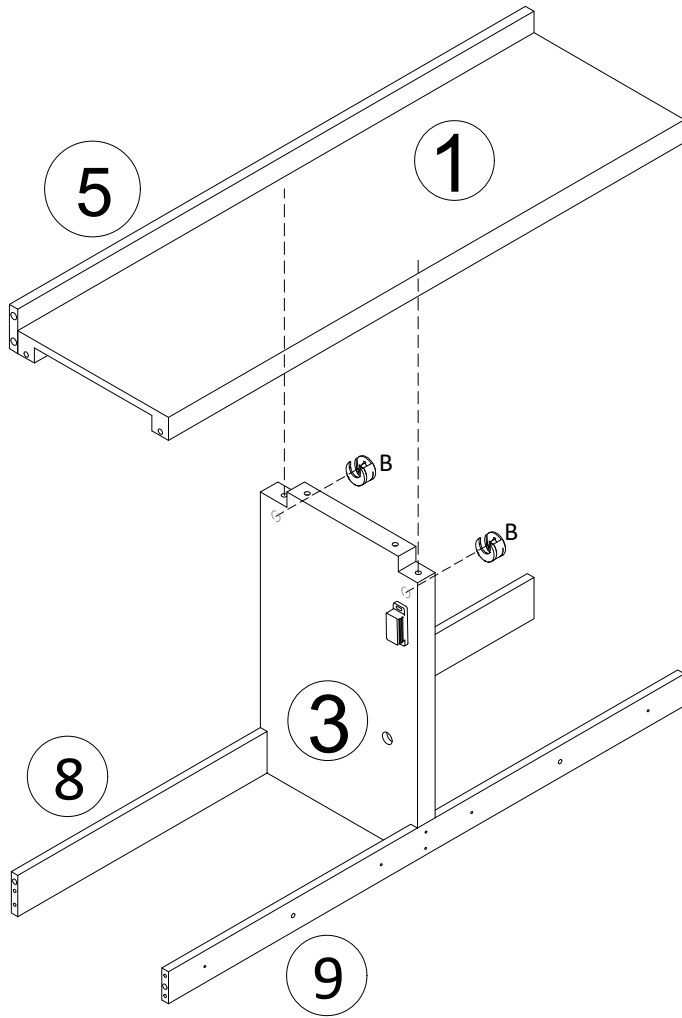

9

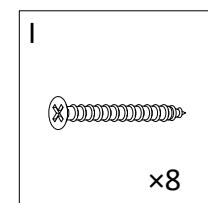
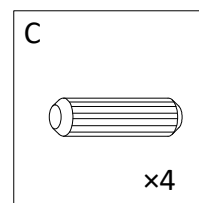
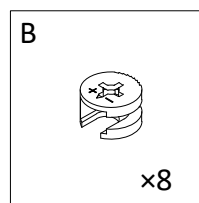
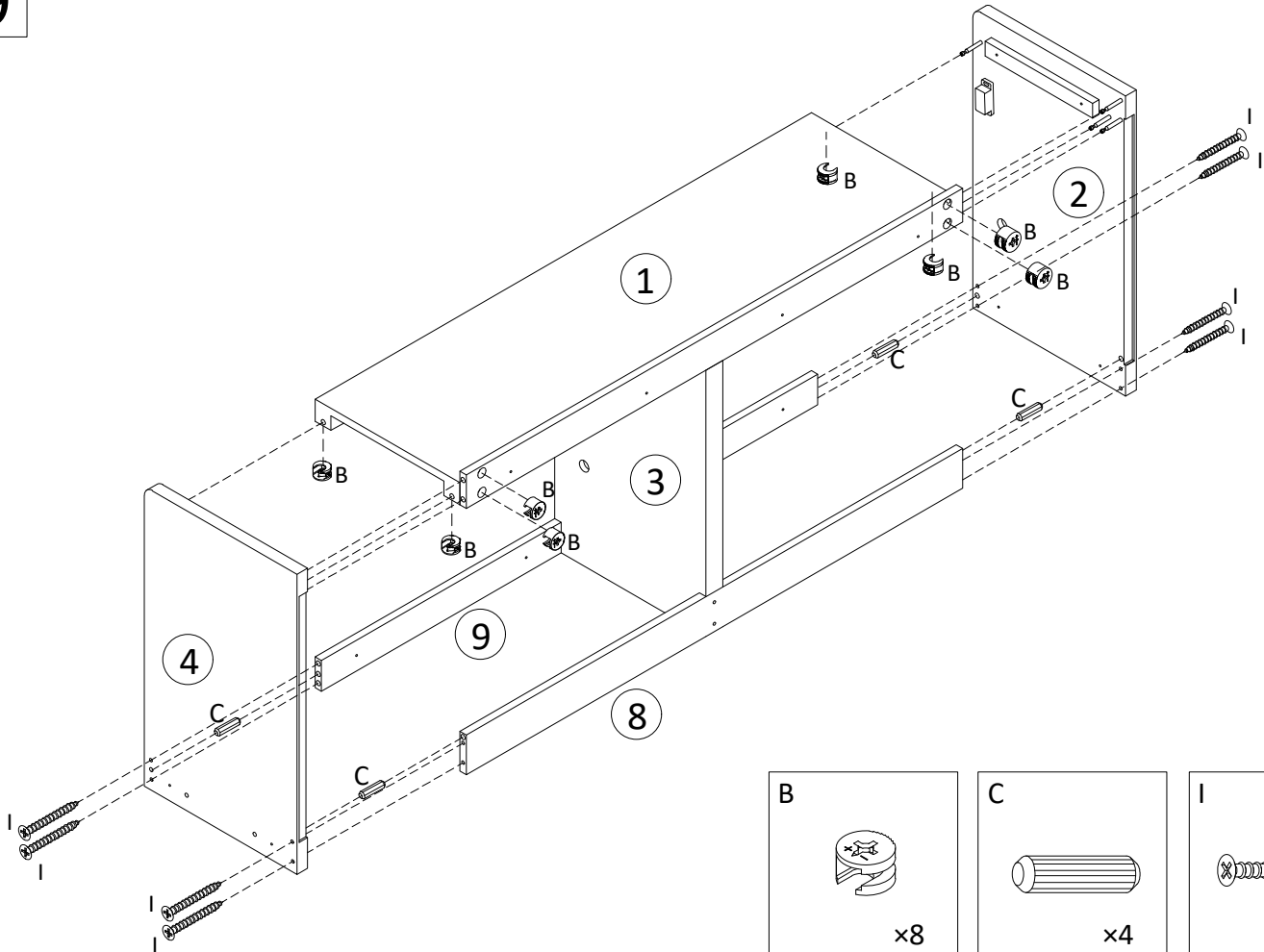

10

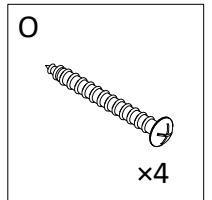
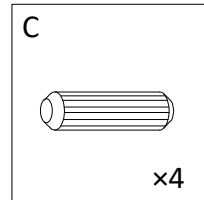
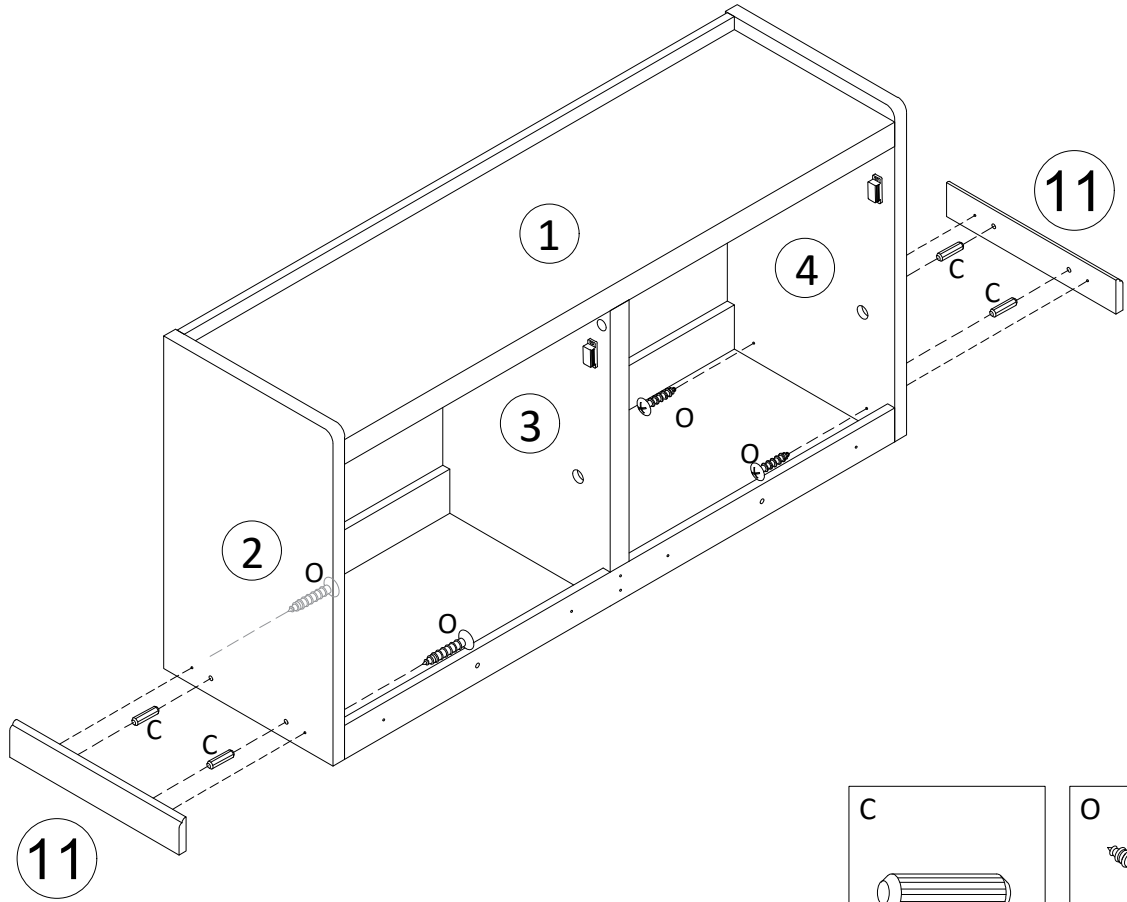

11

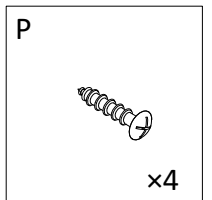
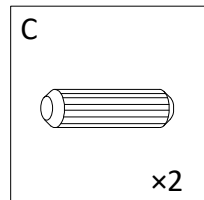
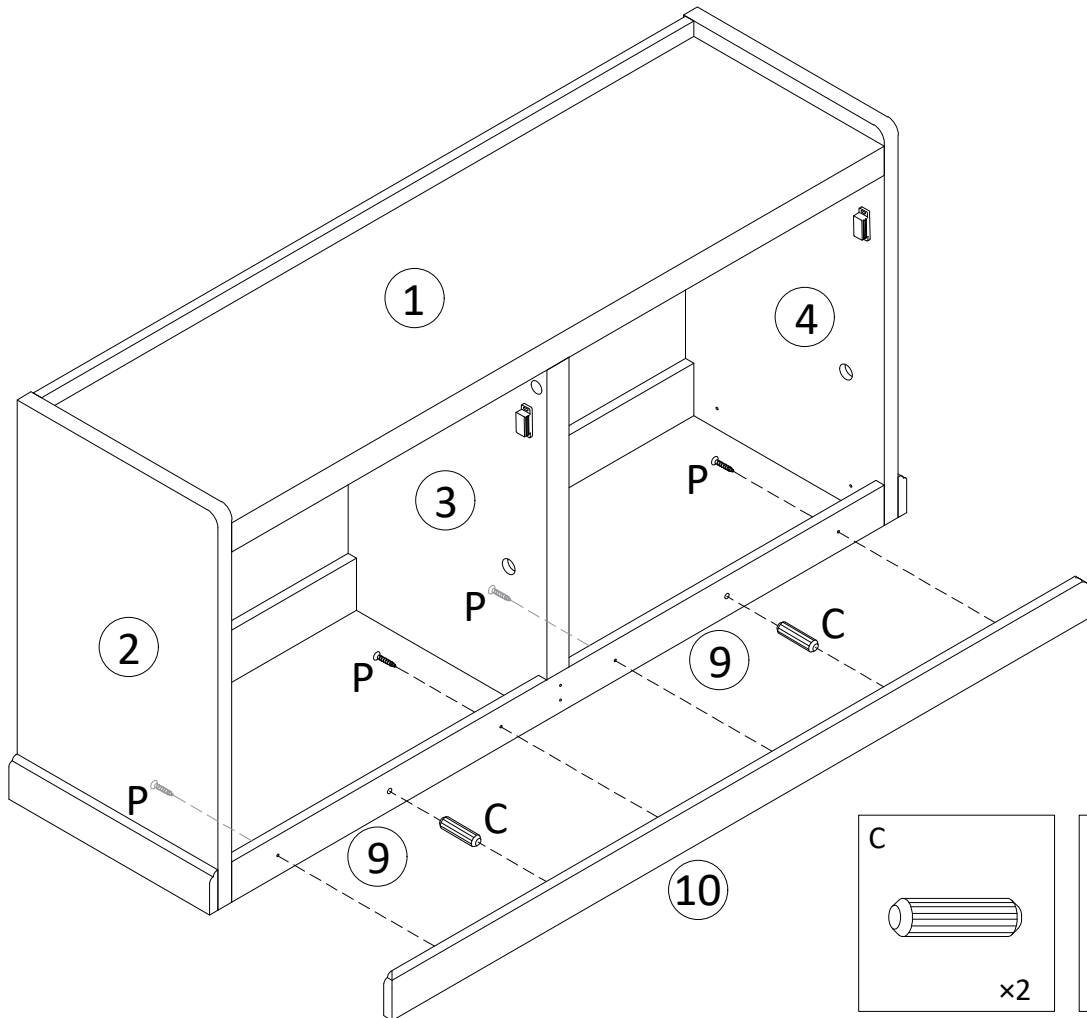

12

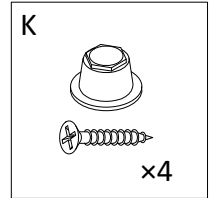
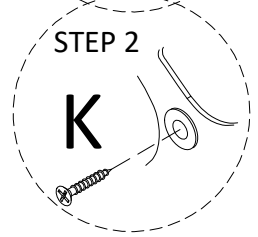
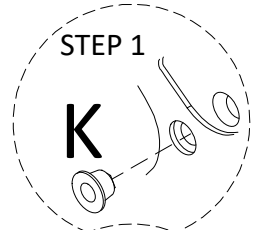
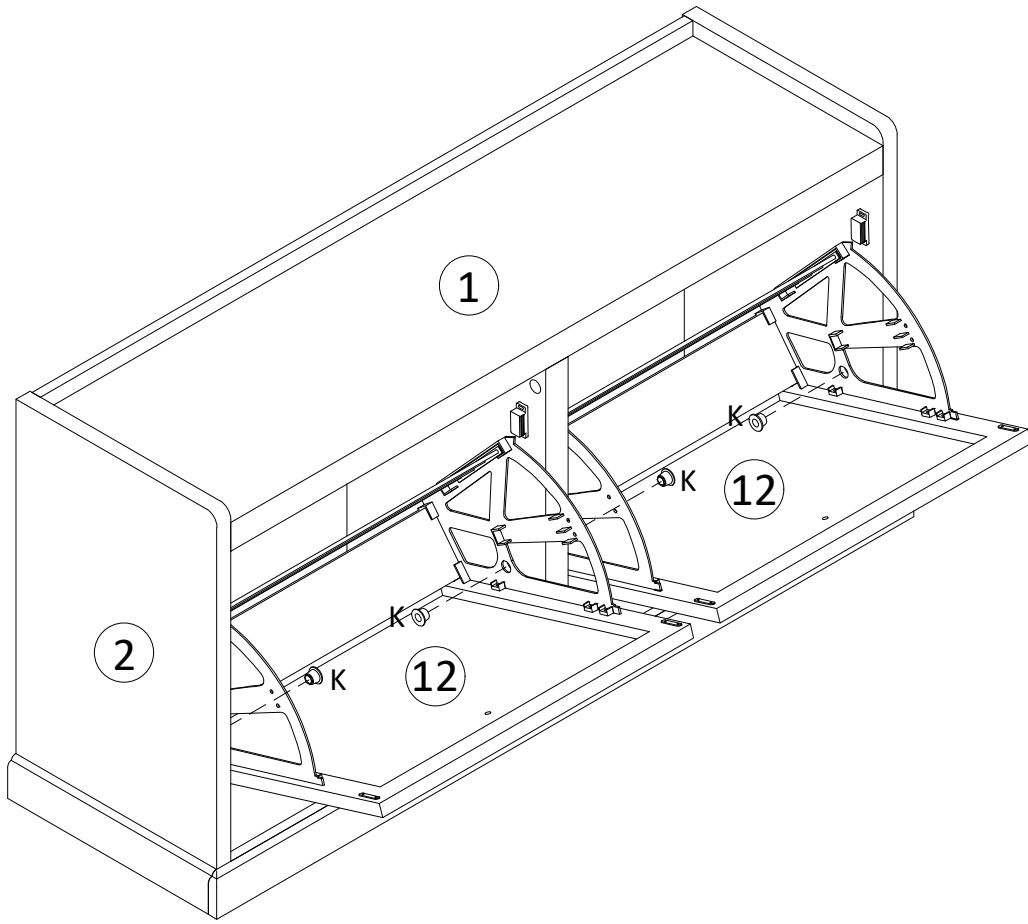

13

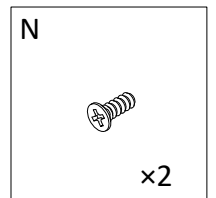
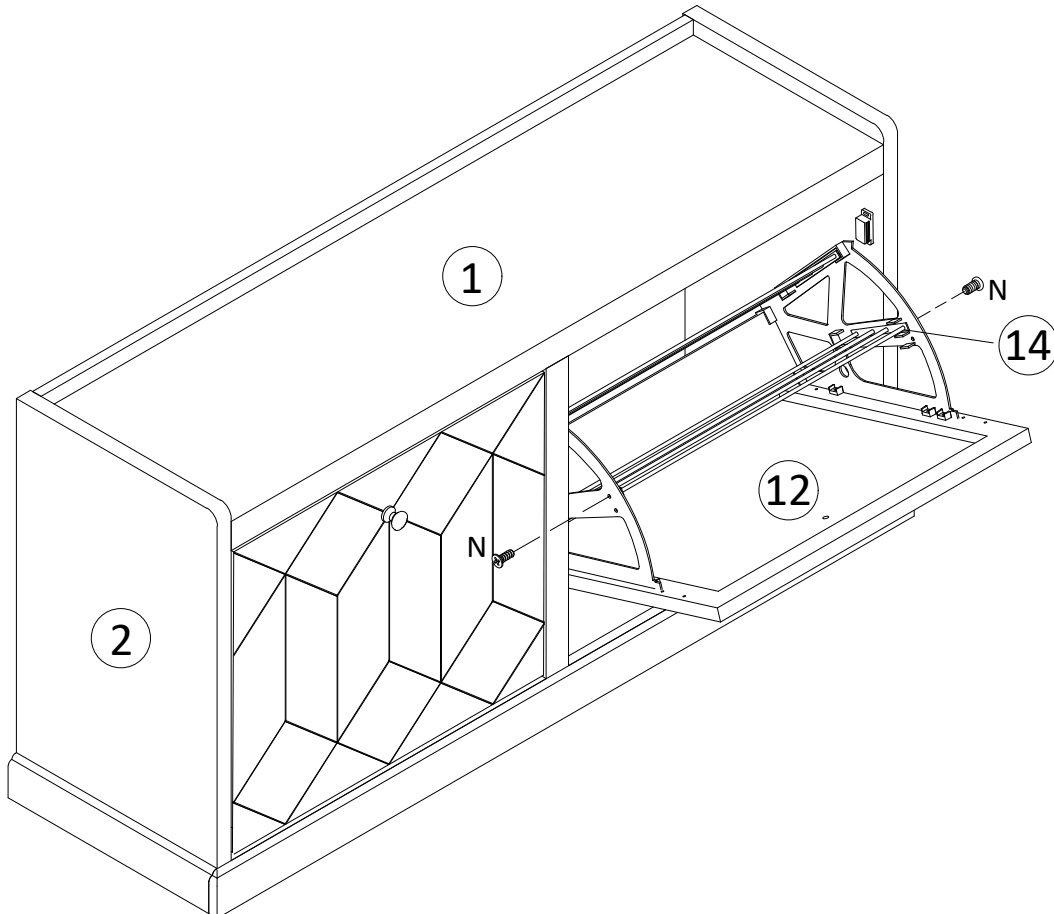

14

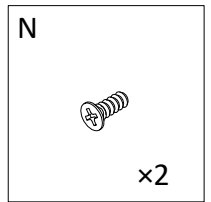
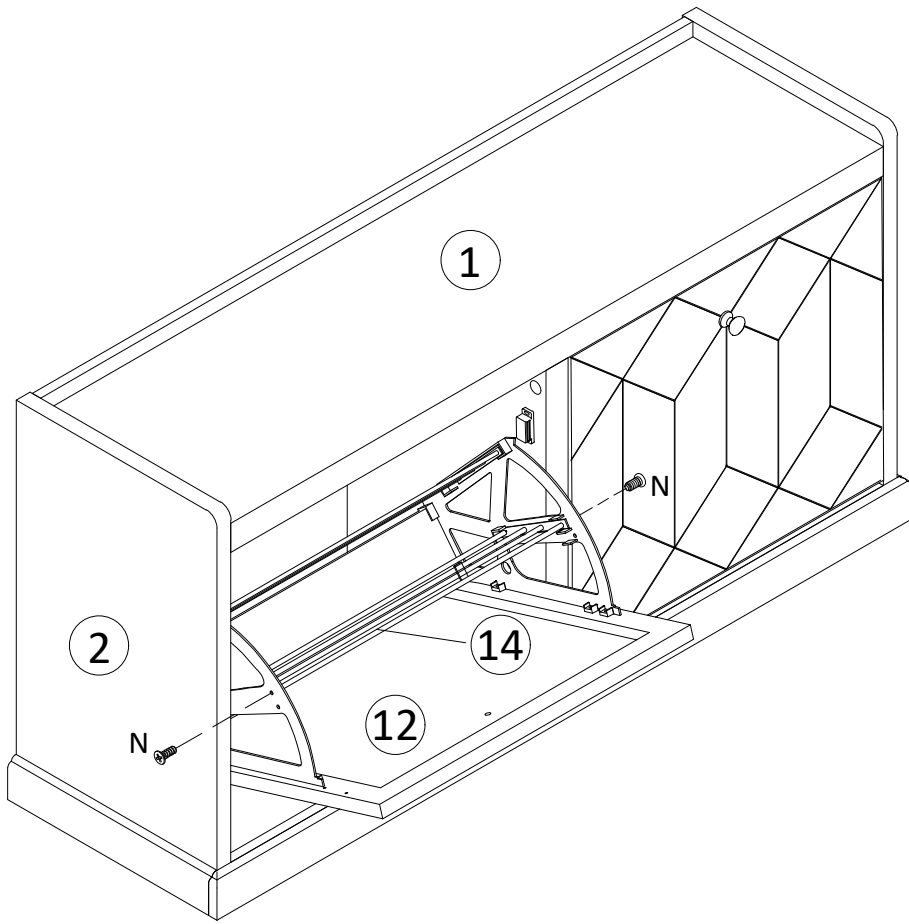

15

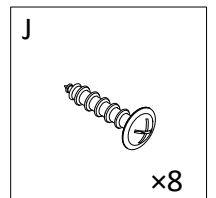
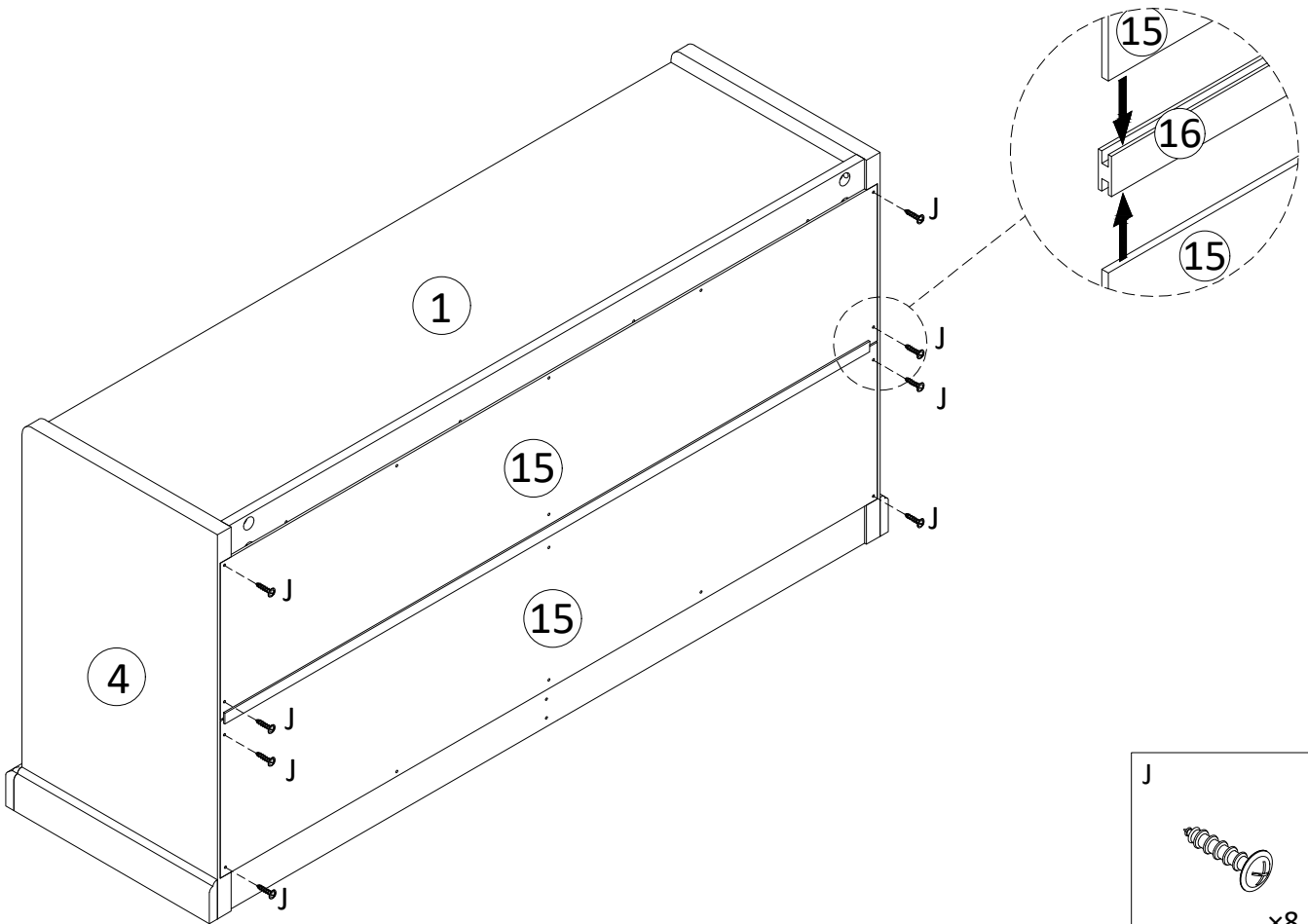

16

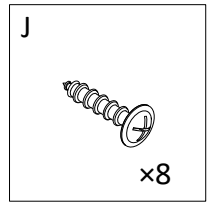
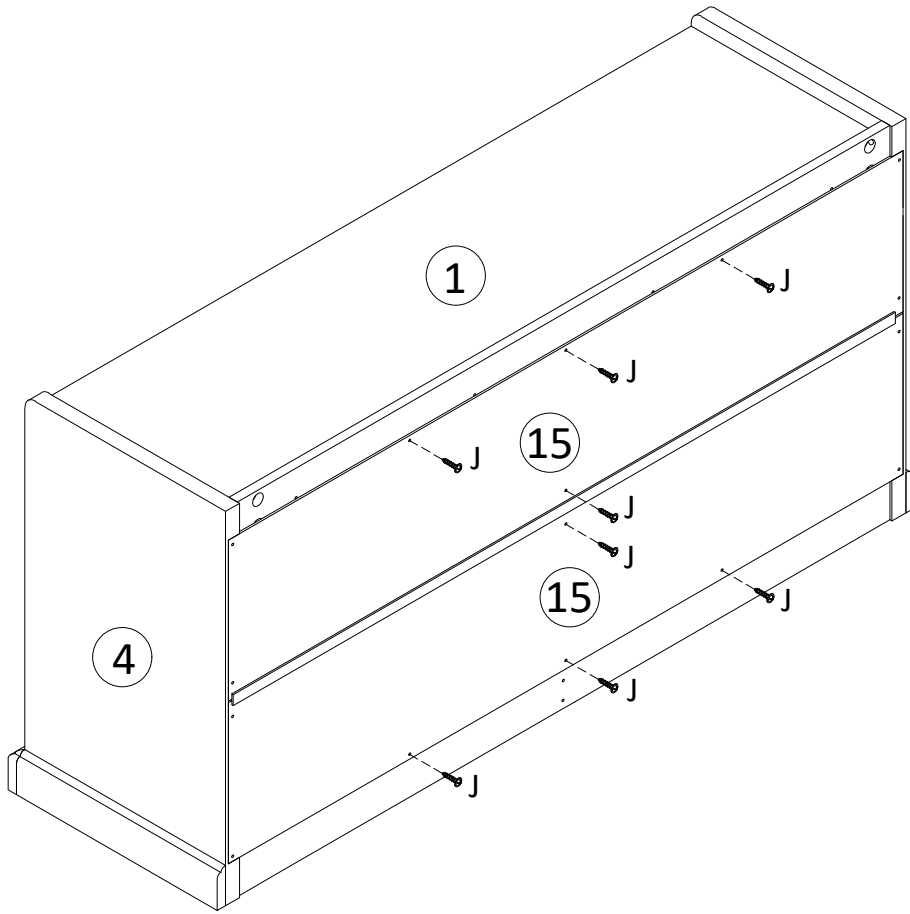

17

