



**EN** - For your convenience, please prepare a power drill before installation. (Tool not included)

**DE** - Für eine reibungslose Montage wird eine Bohrmaschine empfohlen (nicht im Lieferumfang enthalten).

**ES** - Para su comodidad, prepare un taladro eléctrico antes de la instalación. (Herramienta no incluida)

**FR** - Pour plus de commodité, veuillez préparer une perceuse électrique avant l'installation. (Outil non inclus)

**IT** - Per comodità, si consiglia di preparare un trapano elettrico prima dell'installazione. (Attrezzo non incluso)

## 614683(Full)

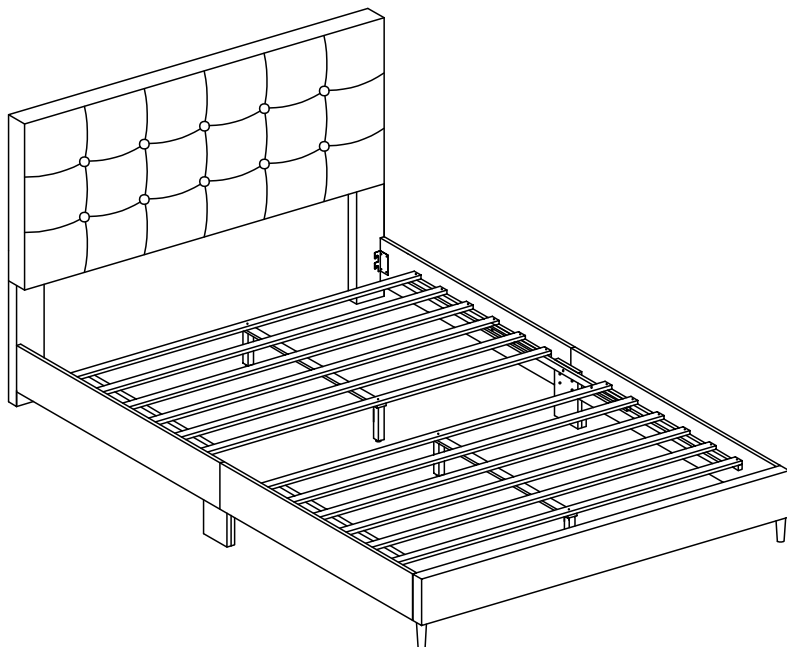

**EN** - Please read this instruction manual carefully before attempting to install.

**DE** - Bitte lesen Sie diese Bedienungsanleitung vor der Montage gründlich durch.

**ES** - Por favor lea con atención el manual de instrucciones antes de llevar a cabo el ensamble.

**FR** - Lisez attentivement cette notice avant de commencer le montage.

**IT** - Si prega di consultare il libretto delle istruzioni prima del montaggio.

# IMPORTANT/WICHTIG/ATENCIÓN

## IMPORTANT/IMPORTANTE



**EN** - We recommend **2** or more people to install.  
**DE** - Wir empfehlen, dass die Montage von **2** oder mehreren Personen durchgeführt werden sollte.  
**ES** - Recomendamos realizar el ensamble con **2** o más personas.  
**FR** - Il est recommandé d'effectuer le montage à **2** personne(s) ou plus.  
**IT** - È necessaria la presenza di **2** o più persone per il montaggio di questo prodotto.



**EN** - The expected assembly time is **1.5 h**.  
**DE** - Die Montagezeit beträgt durchschnittlich **1.5 h**.  
**ES** - El tiempo aproximado de ensamble es de **1.5 h**.  
**FR** - Le temps nécessaire est estimé à **1.5 h**.  
**IT** - Il tempo previsto per il corretto assemblaggio è di **1.5 h**.



**EN** - Not intended for use by children.  
**DE** - Nicht geeignet für Kinder.  
**ES** - Producto no apto para niños.  
**FR** - Produit non destiné à être utilisé par des enfants.  
**IT** - Questo prodotto non è destinato all'uso da parte dei bambini.











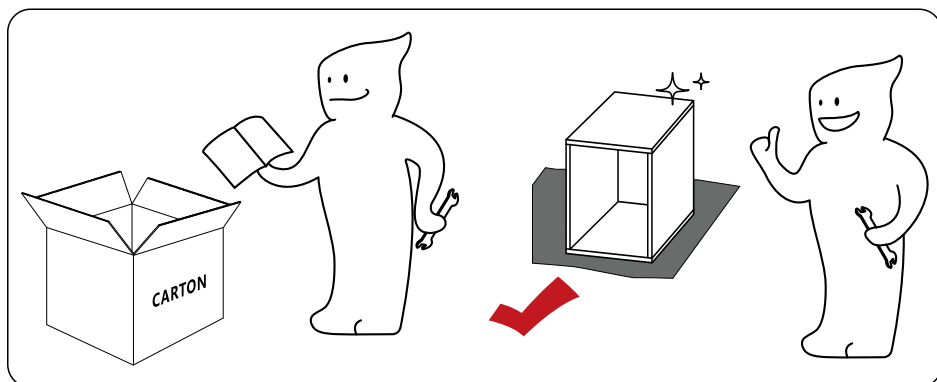
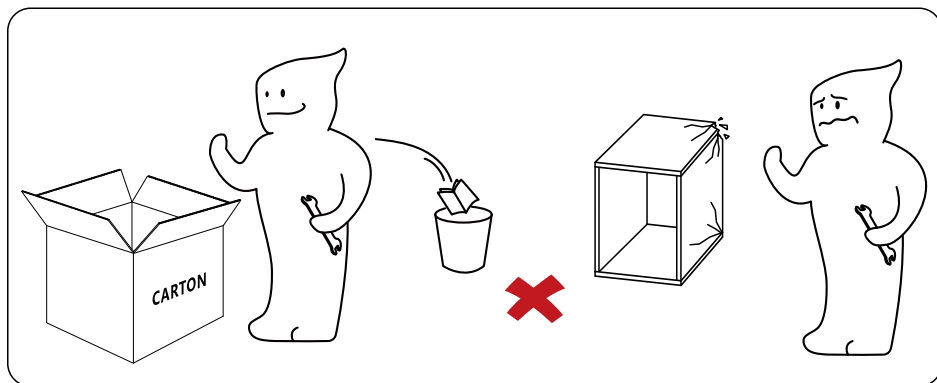

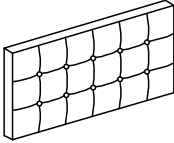

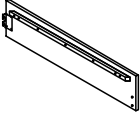
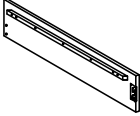
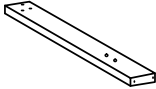

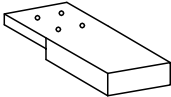
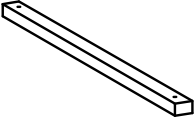
**EN** - Keep away from fire or other heat sources.  
**DE** - Bitte von Feuer und Hitzequellen fernhalten.  
**ES** - Manténgase alejado de las llamas y otras fuentes de calor.  
**FR** - Tenir à distance des flammes et autres sources de chaleur.  
**IT** - Tenere lontano dal fuoco o da altre fonti di calore.



**EN** - We recommend wearing protective gloves.  
**DE** - Wir empfehlen das Tragen von Schutzhandschuhen.  
**ES** - Recomendamos el uso de guantes de seguridad.  
**FR** - Il est recommandé de porter des gants de protection.  
**IT** - Per il processo di assemblaggio, consigliamo fortemente l'utilizzo di guanti protettivi.

- EN** - Please follow the instruction manuals and use a pad to avoid damage during assembly.
- DE** - Bitte folgen Sie der Anleitung und verwenden Sie eine Unterlage, um Beschädigungen bei der Montage zu vermeiden.
- ES** - Por favor, siga las instrucciones del manual y utilice una cubierta o lona para proteger el producto y el suelo durante la instalación.
- FR** - Suivez les instructions de la notice et utilisez une couverture ou une bâche pour protéger le produit et les sols pendant le montage.
- IT** - Si prega di consultare il manuale illustrativo durante il montaggio e di utilizzare un cuscinetto per evitare possibili danni.

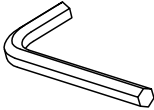

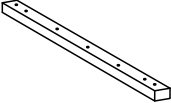
<p>(A) X 1</p> 	<p>(B) X 1</p> 	<p>(C1) X 2</p> 	<p>(C2) X 2</p> 
<p>(D) X 2</p> 	<p>(E) X 2</p> 	<p>(F) X 2</p> 	<p>(G) X 2</p> 
<p>(H) X 2</p> 	<p>(I) X 4</p> 	<p>(J) X 36</p> 	<p>(K) X 8</p> 
<p>(L) X 14</p> 	<p>(M) X 4</p> 	<p>(N) X 1</p> 	<p>(O) X 1</p> 
<p>(P) X 8</p> 	<p>(Q) X 6</p> 	<p>(R) X 2</p> 	

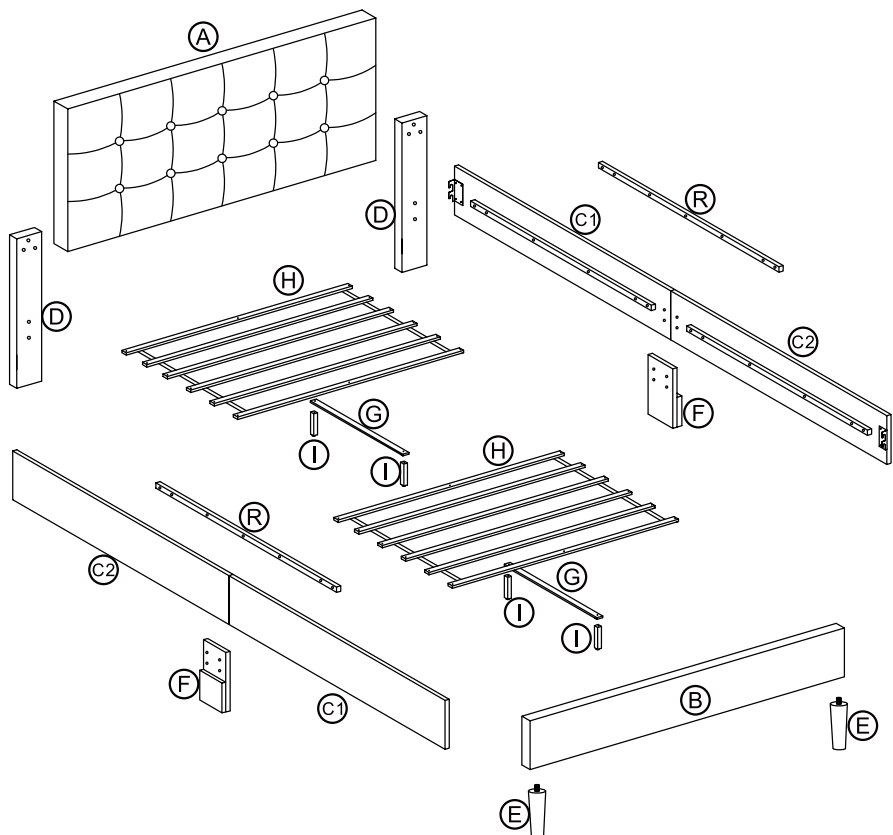



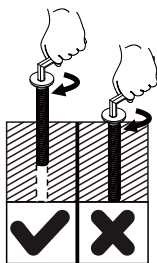

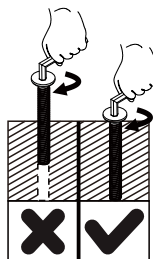

- EN** - Half tighten the screw  
**DE** - Bitte die Schraube nur halb festziehen  
**ES** - Apretar el tornillo a la mitad  
**FR** - Ne serrez la vis que jusqu'à la moitié  
**IT** - Stringere la vite a metà



- EN** - Note: Tighten all screws completely after assembly.  
**DE** - Hinweis: Ziehen Sie nach der Montage alle Schrauben vollständig an.  
**ES** - Nota: Apretar completamente todos los tornillos después de montar.  
**FR** - NB : Serrez les vis complètement après l'assemblage.  
**IT** - Nota: Stringere completamente tutte le viti solo dopo l'assemblaggio.

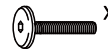

# 1

(A)		x1
(B)		x1
(D)		x2
(E)		x2
(L)		x6
(Q)		x6

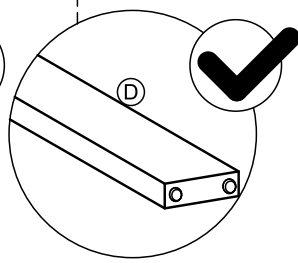
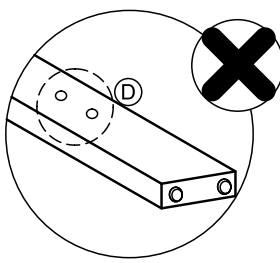
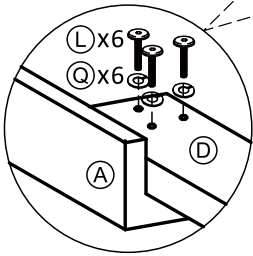
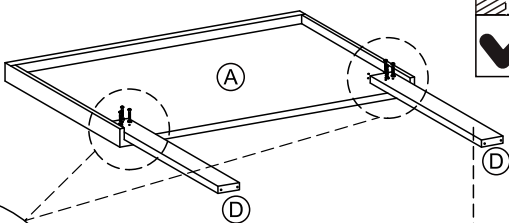
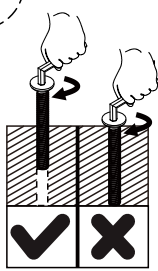
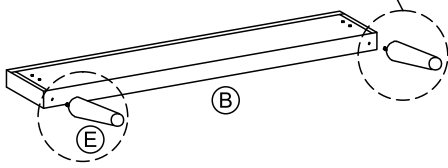
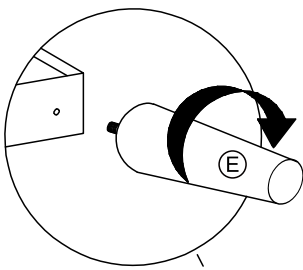

**EN** - Please pay attention to the direction of Part (D) when installing.  
**DE** - Bitte bei der Montage die Richtung von Teil (D) beachten.  
**ES** - Por favor preste atención a la dirección de la pieza (D) al instalar.  
**FR** - Veuillez à bien respecter l'orientation de l'élément (D) lors du montage.  
**IT** - Si prega di fare attenzione al verso della parte (D) durante il montaggio.

2

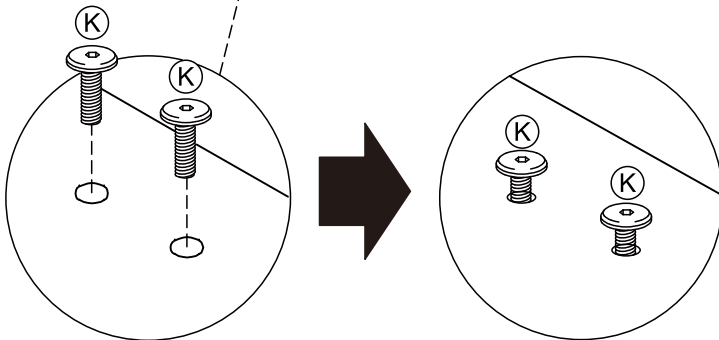
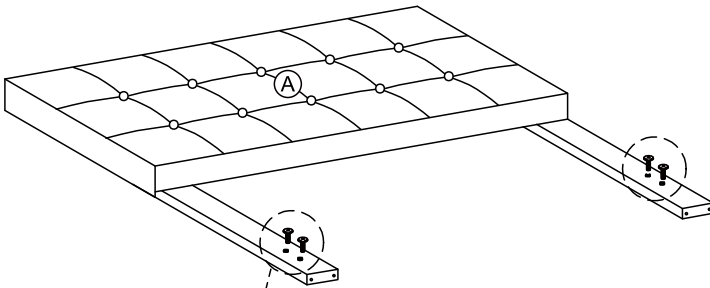
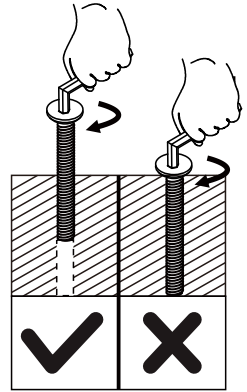
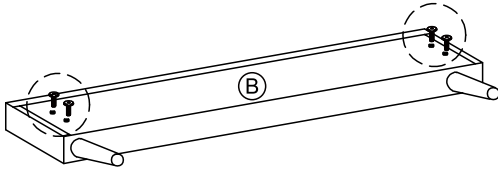
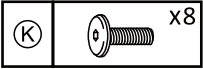

3

(C1)		x2
(C2)		x2
(F)		x2
(L)		x8
(P)		x8

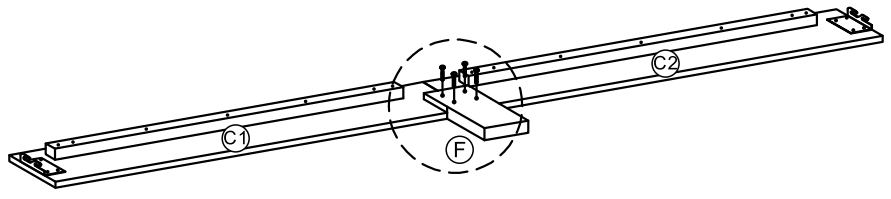
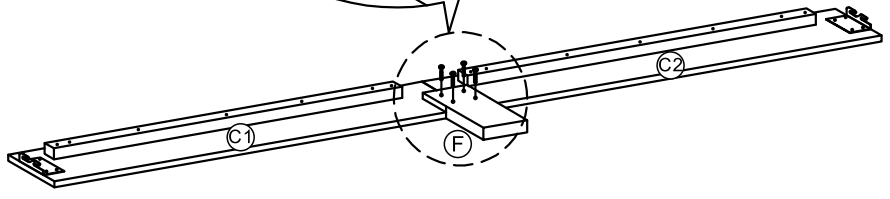
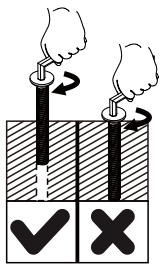
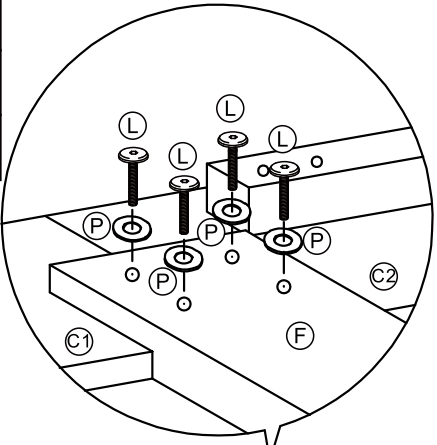

4

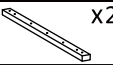
(J)	 x12
(R)	 x2

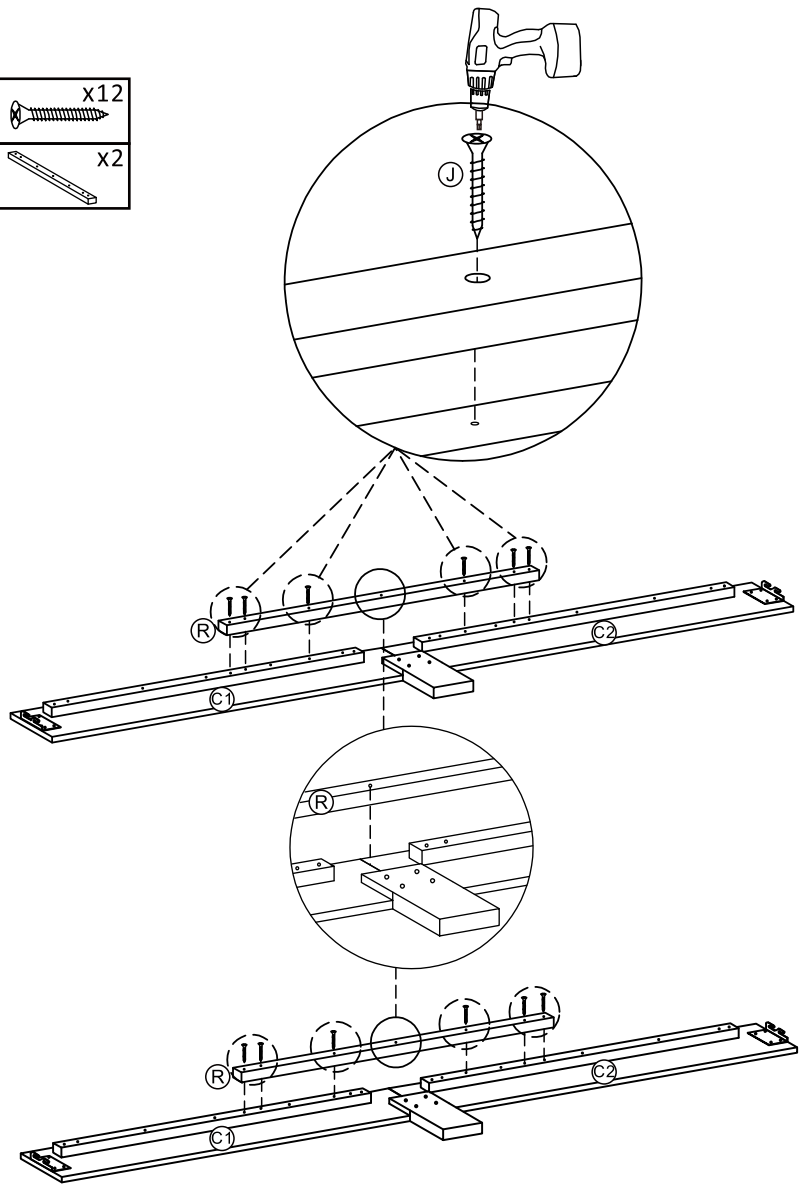

**EN** - Please use an electric screwdriver.  
**DE** - Bitte verwenden Sie einen elektrischen Schraubendreher.  
**ES** - Utilice un destornillador eléctrico.  
**FR** - Veuillez utiliser un tournevis électrique.  
**IT** - Si prega di utilizzare un cacciavite elettrico.

5

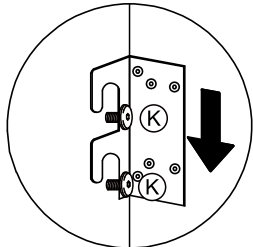

NO.1

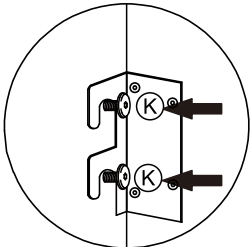



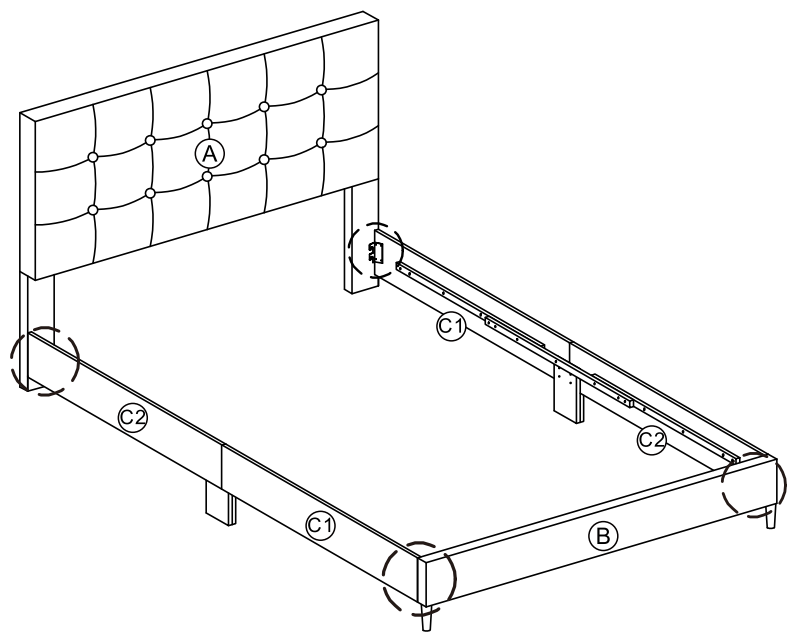

NO.2



	<b>EN</b> - Assembly requires 2 adults.
	<b>DE</b> - Die Montage erfordert 2 Erwachsene.
	<b>ES</b> - Para el montaje se necesitan 2 adultos.
	<b>FR</b> - L'assemblage nécessite 2 adultes.
	<b>IT</b> - Il montaggio richiede 2 adulti.

<b>EN</b> - Note: Tighten all screws completely after assembly.
<b>DE</b> - Hinweis: Ziehen Sie nach der Montage alle Schrauben vollständig an.
<b>ES</b> - Nota: Apretar completamente todos los tornillos después de montar.
<b>FR</b> - NB : Serrez les vis complètement après l'assemblage.
<b>IT</b> - Nota: Stringere completamente tutte le viti solo dopo l'assemblaggio.

6

(G)		x2
(H)		x2
(I)		x4
(M)		x4

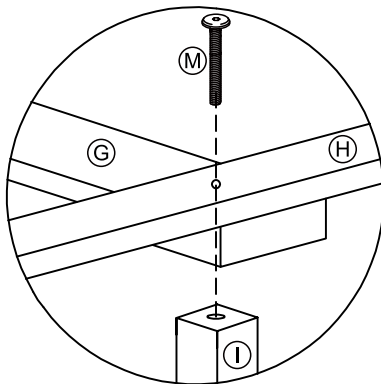
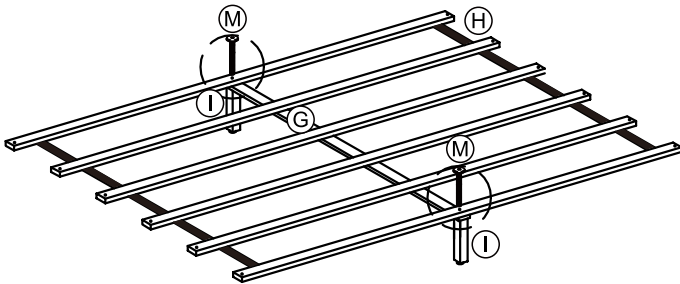
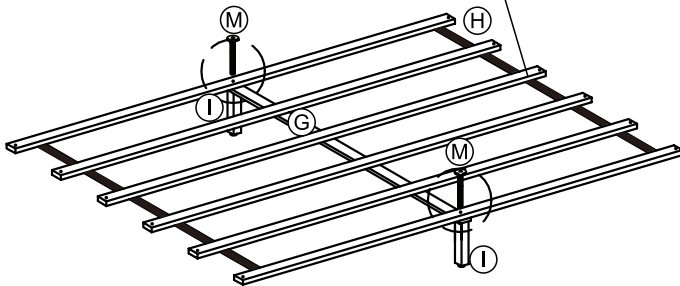
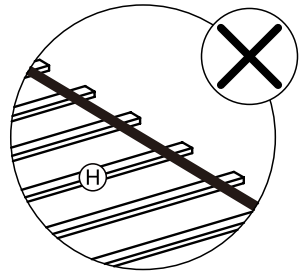
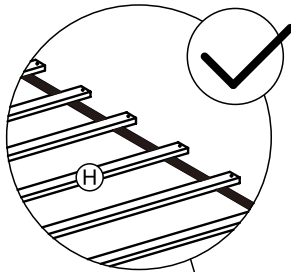

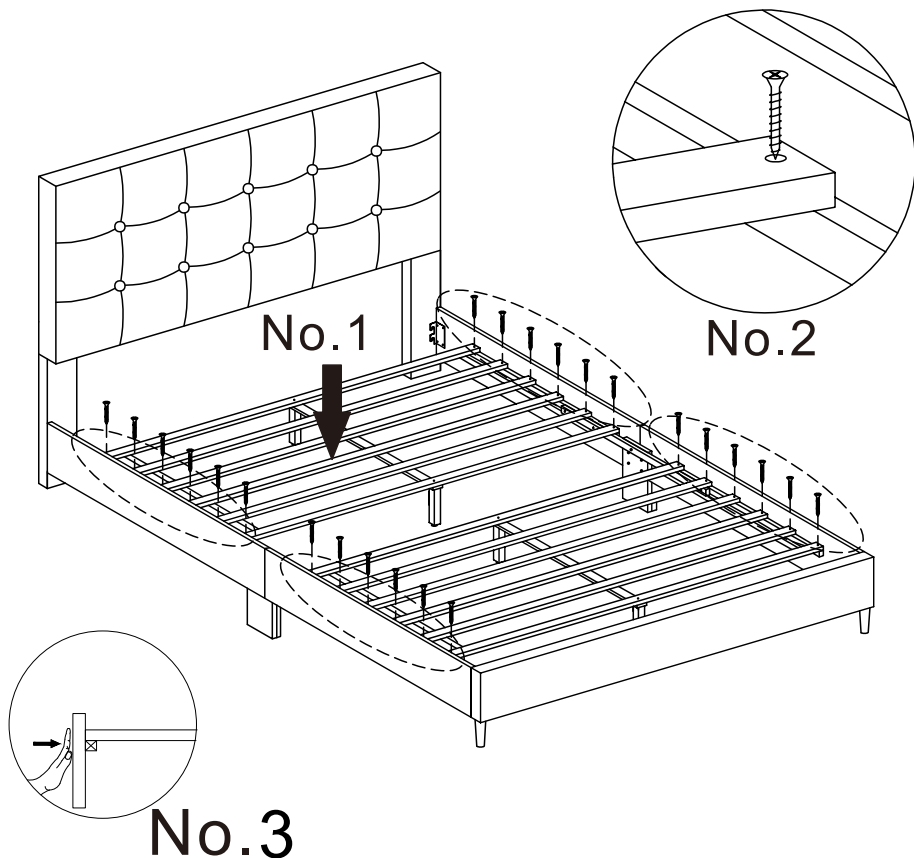

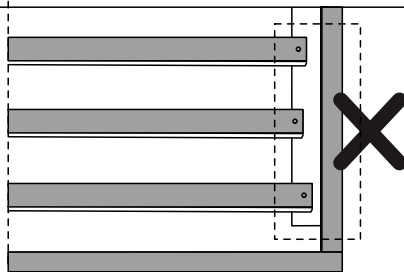
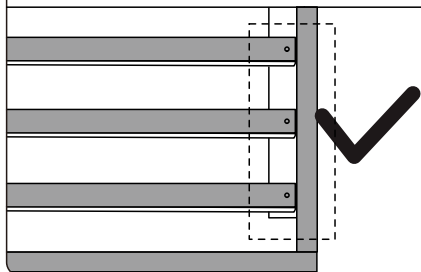

- EN** - Ensure both ends of the slats are tightly fitted to the side panels with no gaps.
- DE** - Stellen Sie sicher, dass beide Enden der Latten fest und lückenlos an den Seitenteilen befestigt sind.
- ES** - Asegúrese de que ambos extremos de los listones encajan perfectamente en los paneles laterales, sin dejar espacio.
- FR** - Veillez à ce que les deux extrémités des lattes soient bien ajustées aux panneaux latéraux, sans aucun écart.
- IT** - Assicurati che entrambe le estremità delle doghe siano ben aderenti nei pannelli laterali, senza spazi vuoti.

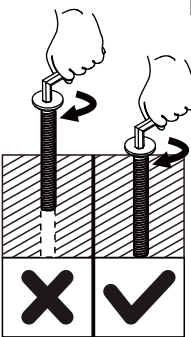
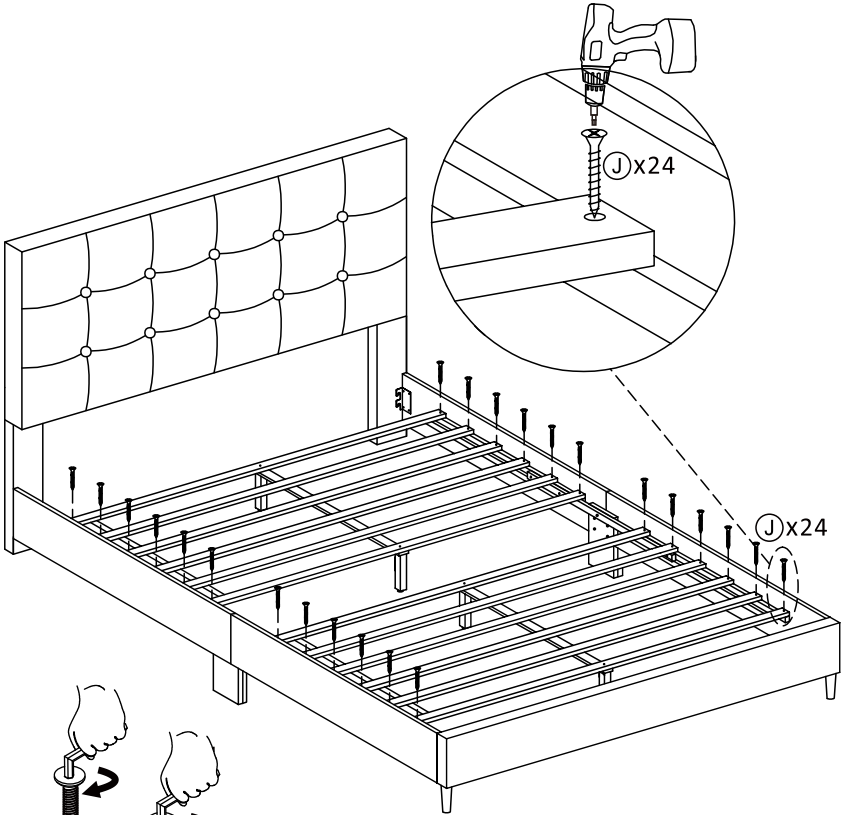
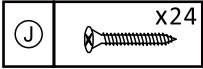

7



	<p>EN - Please use an electric screwdriver. DE - Bitte verwenden Sie einen elektrischen Schraubendreher. ES - Utilice un destornillador eléctrico. FR - Veuillez utiliser un tournevis électrique. IT - Si prega di utilizzare un cacciavite elettrico.</p>
---	---

**EN:Furniture Care Instructions**

1. Use a soft, clean cloth or sponge to gently wipe the outer surface of the product to remove dust and dirt.
2. Avoid using chemical cleaners or harsh solvents to prevent damage to the appearance of the product.
3. Inspect the fittings (bolts, screws, nuts, etc.) every 3 months and re-tighten them every 6 months.
4. Avoid direct sunlight.

If the furniture shows structural damage or poses a safety hazard, stop using it until it is repaired.

5. Please seek professional help with the installation of the sink drain pipe.

**DE:Pflegehinweise für Möbel**

1. Wischen Sie die Oberfläche des Produkts vorsichtig mit einem weichen, sauberen Tuch oder Schwamm ab, um Staub und Schmutz zu entfernen.
2. Verwenden Sie keine chemischen Reinigungsmittel oder starke Lösungsmittel, die das Produkt beschädigen könnten.
3. Prüfen Sie die Beschläge (Bolzen, Schrauben, Muttern usw.) alle 3 Monate und ziehen Sie sie alle 6 Monate nach.
4. Vermeiden Sie direktes Sonnenlicht.

Wenn das Möbelstück strukturell beschädigt oder ein potenzielles Sicherheitsrisiko darstellt, benutzen Sie es bitte nicht mehr, bis es repariert ist.

5. Bitte holen Sie sich professionelle Hilfe bei der Installation des Abflussrohrs.

**ES:Instrucciones para el cuidado de los muebles**

1. Utilice un paño suave y limpio o una esponja para limpiar suavemente la superficie exterior del producto para eliminar el polvo y la suciedad.
2. Evite el uso de limpiadores químicos o disolventes fuertes para evitar dañar la apariencia del producto.
3. Inspeccione los herrajes (pernos, tornillos, tuercas, etc.) cada 3 meses y vuelva a apretarlos cada 6 meses.
4. Evite la luz solar directa.

Si el mueble presenta daños estructurales o supone un peligro para la seguridad, deje de utilizarlo hasta que sea reparado.

5. Solicite ayuda profesional para la instalación de la tubería de desagüe del fregadero.

**FR:Conseils pour l'entretien des meubles**

1. Utilisez un chiffon doux et propre ou une éponge pour nettoyer délicatement la surface du meuble et éliminer la poussière et les saletés.
  2. Évitez d'utiliser des produits chimiques ou du détergent trop fort pour ne pas abîmer l'aspect du meuble.
  3. Vérifiez les fixations (boulons, vis, écrous, etc.) tous les 3 mois et resserrez-les tous les 6 mois.
  4. Évitez d'exposer le meuble aux rayons directs du soleil.
- Si le meuble présente des signes de détérioration ou de danger, arrêtez de l'utiliser jusqu'à ce qu'il soit réparé.
5. Pour l'installation du tuyau d'évacuation de l'évier, veuillez solliciter l'assistance d'un professionnel

**IT:Istruzioni per la Cura dei Mobili**

1. Con un panno o una spugna morbida e pulita, pulire delicatamente la superficie del prodotto per rimuovere polvere e sporco.
  2. Evitare l'uso di detersivi chimici o solventi aggressivi per non danneggiare l'aspetto del prodotto.
  3. Ispezionare i raccordi (bulloni, viti, dadi, ecc.) ogni 3 mesi e serrarli nuovamente ogni 6 mesi.
  4. Evitare la luce diretta del sole.
- Se i mobili sono strutturalmente danneggiati o rappresentano un pericolo per la sicurezza, sospendere l'uso fino alla riparazione.
5. Rivolgersi a un professionista per l'installazione del tubo di scarico del lavandino.

**EN: Upholstered Furniture Care Instructions**

If the product becomes stained, you can use a specific upholstery cleaner sprayed onto the stain. Follow this by gently wiping with a soft towel, and avoid scrubbing vigorously to prevent the surface of the product from pilling.

**DE: Pflegehinweise für Polstermöbel**

Sollte das Produkt verschmutzt sein, können Sie einen speziellen Polsterreiniger auf den Fleck sprühen. Wischen Sie dann vorsichtig mit einem weichen Handtuch nach. Vermeiden Sie dabei starkes Reiben, um die Oberfläche vor der Bildung von Pilling zu schützen.

**ES: Instrucciones para el cuidado de muebles tapizados**

Si el producto se mancha, puede utilizar un limpiador específico para tapicerías pulverizado sobre la mancha. A continuación, limpie suavemente con una toalla suave y evite frotar enérgicamente para evitar que la superficie del producto se apelmace.

**FR :Conseils d'entretien pour les meubles rembourrés**

En cas de tache, utilisez un produit nettoyant adapté au tissu d'ameublement et vaporisez-le sur la zone concernée. Puis, tamponnez délicatement avec un chiffon doux et évitez de frotter fort pour ne pas abîmer la surface du meuble.

**IT: Istruzioni per la Cura dei Mobili Imbottiti**

Se il prodotto è macchiato, spruzzare la macchia con un detergente specifico per tappezzeria. Quindi strofinare delicatamente con un panno morbido, evitando di strofinare energicamente per evitare che la superficie del prodotto faccia pilling.

EN



If you are not entirely satisfied with your purchase, please feel free to contact us using the following steps:

1. Go to Your Orders.
2. Find your order in the list.
3. Select Problem with order.
4. Choose your topic from list displayed.
5. Select Contact seller.

Please contact us at: [info@yaheetech.shop](mailto:info@yaheetech.shop)

DE



Sollten Sie mit Ihrem Kauf nicht zufrieden sein, nehmen Sie bitte in folgenden Schritten mit uns Kontakt auf:

1. Gehen Sie auf die Bestellseite
2. Suchen Sie Ihre Bestellung in der Bestellliste
3. Schildern Sie das Problem mit der Bestellung
4. Thema aus der angezeigten Liste auswählen
5. Kontakt mit dem Verkäufer aufnehmen.

Kontaktieren Sie uns unter: [info@yaheetech.shop](mailto:info@yaheetech.shop)

ES



Si no está totalmente satisfecho con su compra, no dude en ponerse en contacto con nosotros siguiendo las siguientes instrucciones:

1. Vaya a la lista de sus ordenes de compra.
2. Localice su pedido en la lista.
3. Seleccione el problema en el pedido.
4. Elija un tema de la lista que se muestra.
5. Seleccione Contactar con el vendedor.

Póngase en contacto con nosotros en: [info@yaheetech.shop](mailto:info@yaheetech.shop)

FR



Si vous n'êtes pas satisfait de votre achat, veuillez nous contacter en procédant comme suit :

1. Allez sur "Vos commandes"
2. Trouvez votre commande dans la liste.
3. Cliquez sur "Signaler un problème"
4. Sélectionnez une catégorie dans la liste déroulante.
5. Cliquez sur "Contactez le vendeur"

Veuillez nous contacter à l'adresse suivante : [info@yaheetech.shop](mailto:info@yaheetech.shop)

IT



Se non siete soddisfatti di questa esperienza dello shopping, non esitate a contattarci per i seguenti passaggi:

1. Vai ai tuoi ordini.
2. Selezionare "l'ordine interessato".
3. Selezionare il problema con l'ordine.
4. Scegli il tuo argomento dalla lista visualizzata.
5. Selezionare "contatta il venditore".

Contattaci all'indirizzo: [info@yaheetech.shop](mailto:info@yaheetech.shop)