







Read this instruction carefully. See hardware and furniture part list for guidance. Be sure all parts are complete, before you assemble. Place all wooden furniture parts on a clean and flat soft surface to prevent from being scratched. Follow the figure to start assembling.

CAUTIONS : 1. Do not FULLY - TIGHTEN the nut or nut bolt until all nut or bolt is ready assembled.
 2. Do not OVER - TIGHTEN the nut or bolt to avoid causing damages to the thread.
 3. Keep all hardware parts out of reach of children.

NOTE : THE LIST AND QUANTITY SHOWN ARE FOR 1 UNIT ASSEMBLY.
 Tool needed : Screwdriver (not provider).

PART LIST		
ITEM	DESCRIPTION	QTY
A	SLAT	1 PC
B	SLAT WITH TRUNDLE	2 PCS
C	SLAT	4 PCS
D	DRAWER PANEL	1 PC
E	DRAWER SUPPORT WOOD	3 PCS
F	PANEL SUPPORT	2 PCS

HARDWARE LIST		
ITEM	DESCRIPTION	QTY
1	JCBC BOLT M6 x 35mm 	13 PCS
2	JCBC BOLT M6 x 60mm 	4 PCS
3	M6 SPRING WASHER 	4 PCS
4	M6 FLAT WASHER 	4 PCS
5	WOOD SCREW M4 x 38mm 	16 PCS
6	M4 ALLEN KEY (BALL SHAPE) 	1 PC

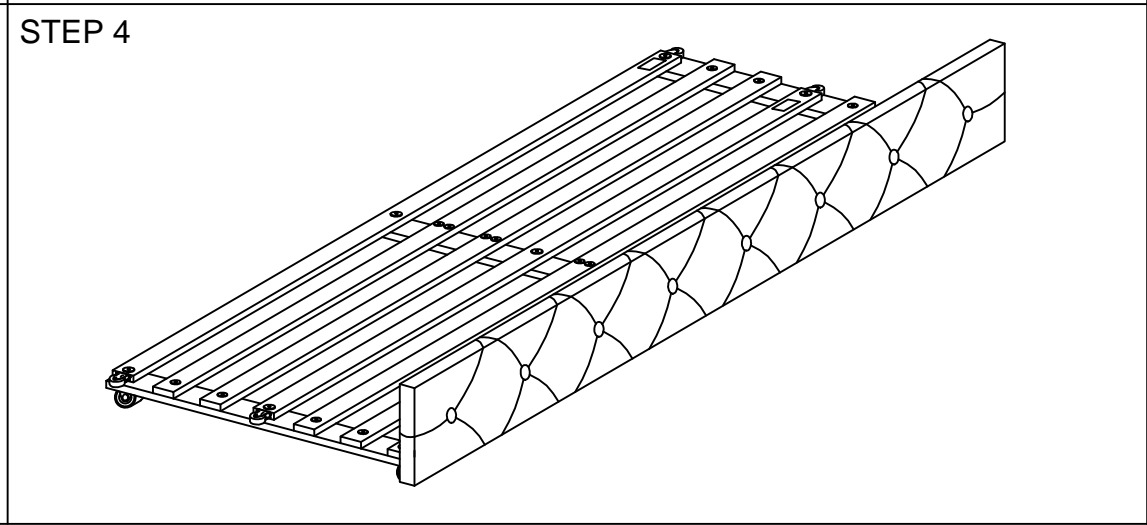
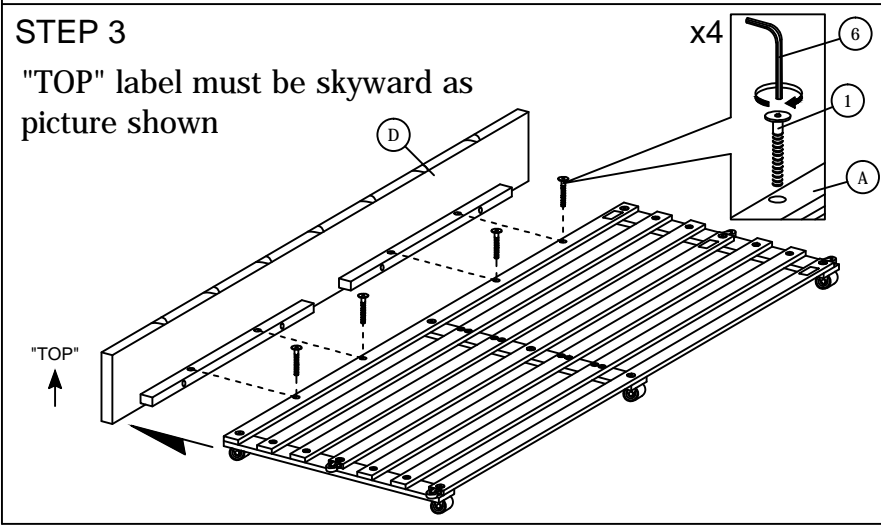
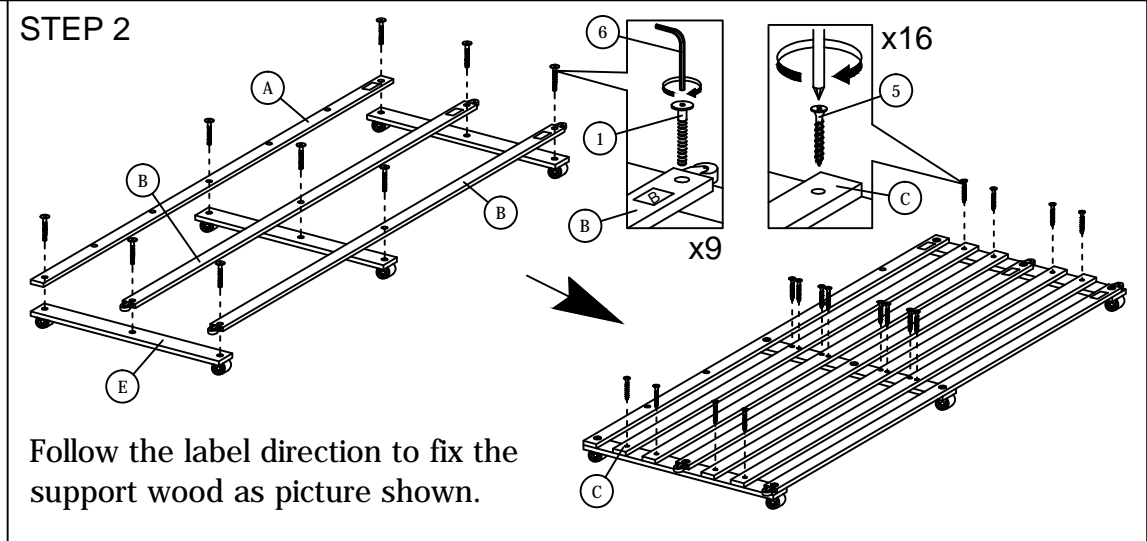
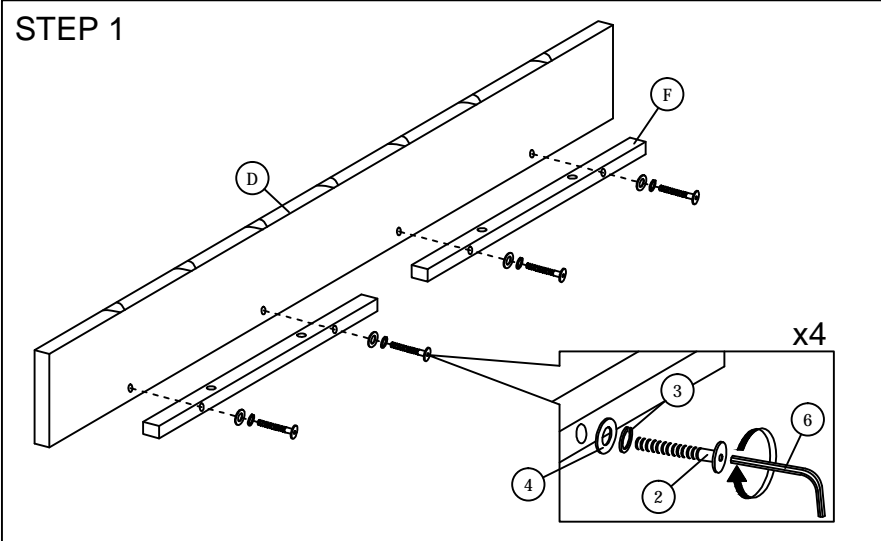

Read this instruction carefully. See hardware and furniture part list for guidance. Be sure all parts are complete, before you assemble. Place all wooden furniture parts on a clean and flat soft surface to prevent from being scratched. Follow the figure to start assembling.

CAUTIONS : 1. Do not FULLY - TIGHTEN the nut or nut bolt until all nut or bolt is ready assembled.
 2. Do not OVER - TIGHTEN the nut or bolt to avoid causing damages to the thread.
 3. Keep all hardware parts out of reach of children.

NOTE : THE LIST AND QUANTITY SHOWN ARE FOR 1 UNIT ASSEMBLY.
 Tool needed : Screwdriver (not provider).

PART LIST		
ITEM	DESCRIPTION	QTY
A	ARM (LEFT)	1 PC
B	ARM (RIGHT)	1 PC
C	SIDE RAIL	2 PCS
D	DRAWER	1 PC
E	BED SLAT	12 PCS
F	CENTER SUPPORT	1 PC

HARDWARE LIST		
ITEM	DESCRIPTION	QTY
1	JCBB BOLT M8 x 40mm	8 PCS
2	BED SLAT SIDE FITTER	24 PCS
3	WOOD SCREW M3.5 x 16mm	4 PCS
4	M5 ALLEN KEY (BALL SHAPE)	1 PC

STEP 1

Loosely fit bolt (3) into Arm(Left) (A) & Arm(Right) (B) as picture shown.

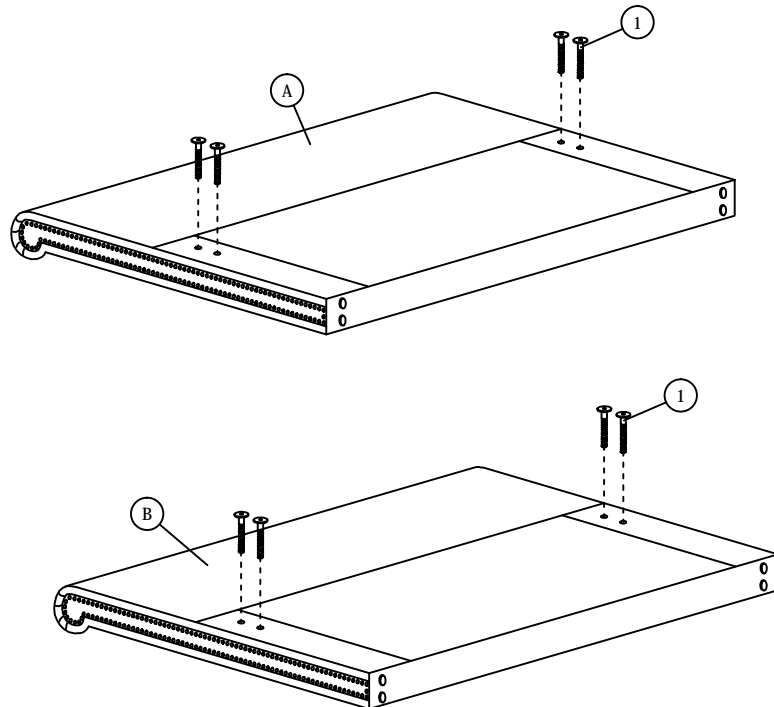

STEP 2

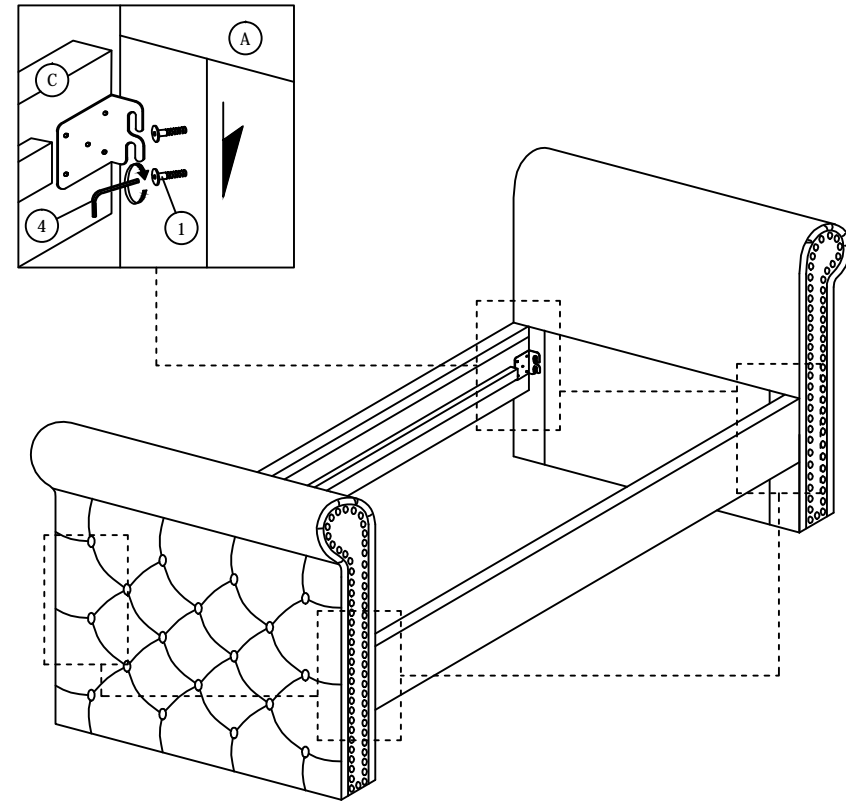

ASSEMBLY INSTRUCTIONS

STEP 3

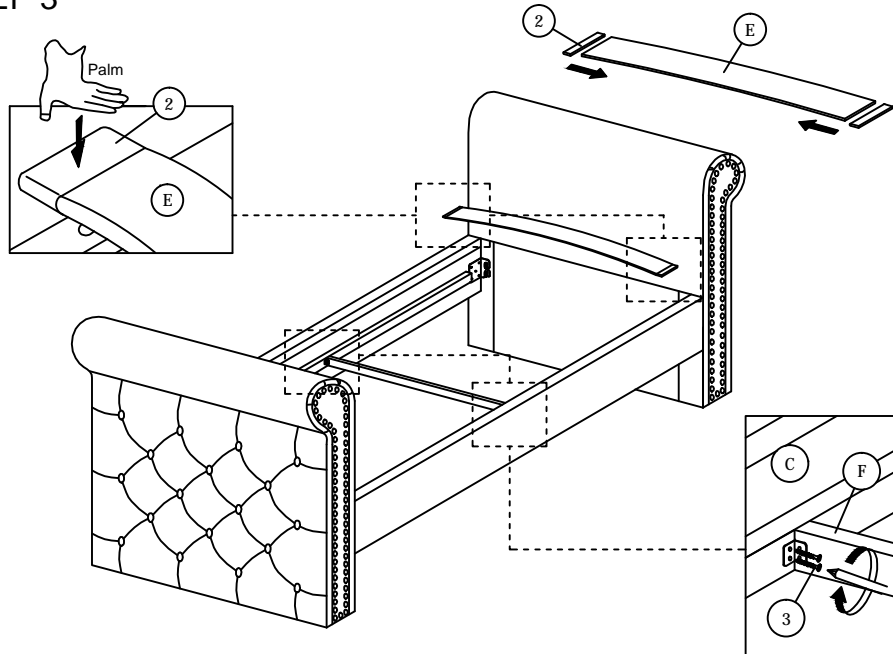

STEP 4

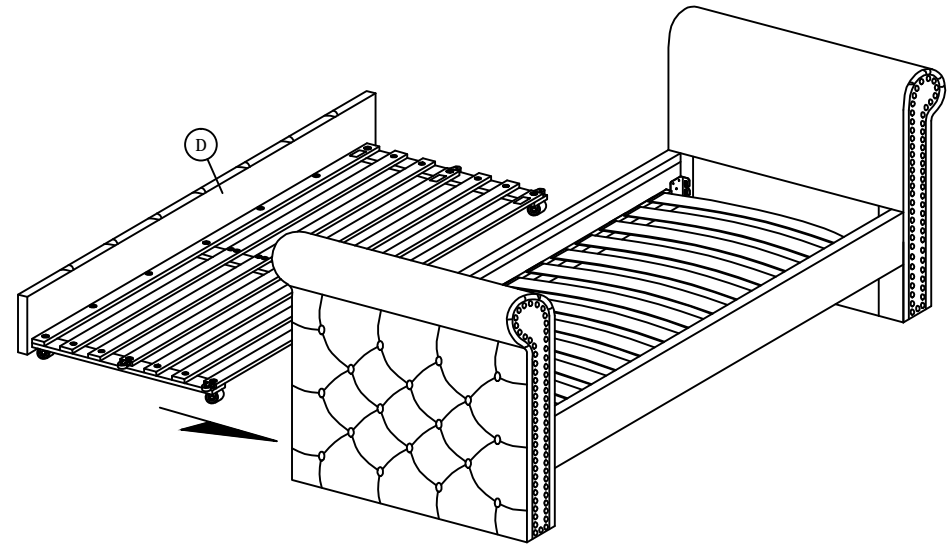

STEP 5

