

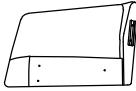

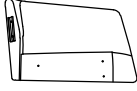

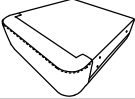

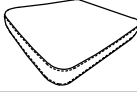

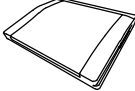

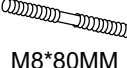

ASSEMBLY INSTRUCTION

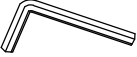
Thank you for purchasing this quality product. Be sure to check all the packing material carefully for small parts, which may have come loose inside the carton during shipment. Identify and count all parts and compare with the HARDWARE LIST below.

PARTS LIST(NO TOOLS REQUIRED)

NO.	DESCRIPTION	PARTS	QTY	NO.	DESCRIPTION	PARTS	QTY
L	Left Armrest		1	R	Right Armrest		1
A	Seat		1	B	Seat Cushion		1
C	Backrest		1	D	Back Cushion		1
E	Throw Pillows		2	F	Headrest		1
G	Bolts	 M8*80MM	6	H	Swivel Base		1
I	Wrench		1	J	Allen Key		1
K	Screws	 M8*60MM	4	M	Flat Washers	 M8*Ø24MM	10
N	Nuts		6	O	Spring Washers		10
P	Felt Pads		12				

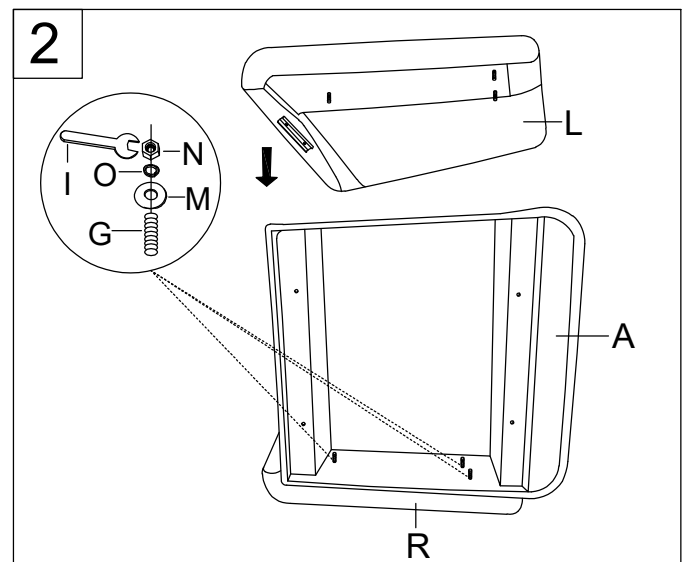
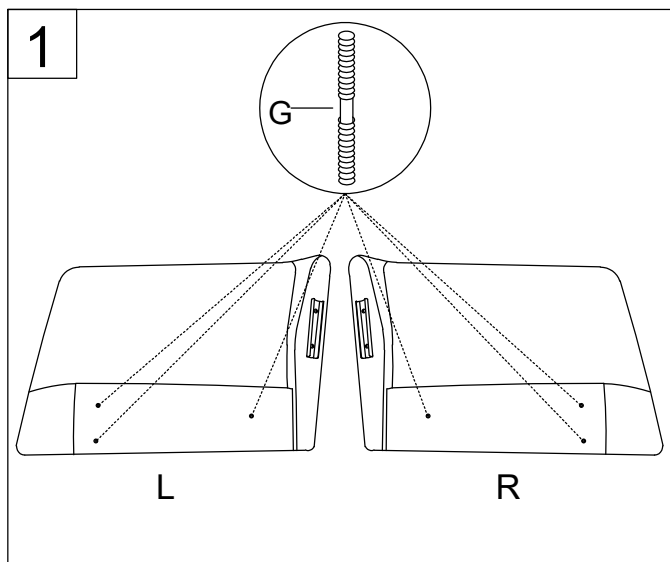

ASSEMBLY INSTRUCTION

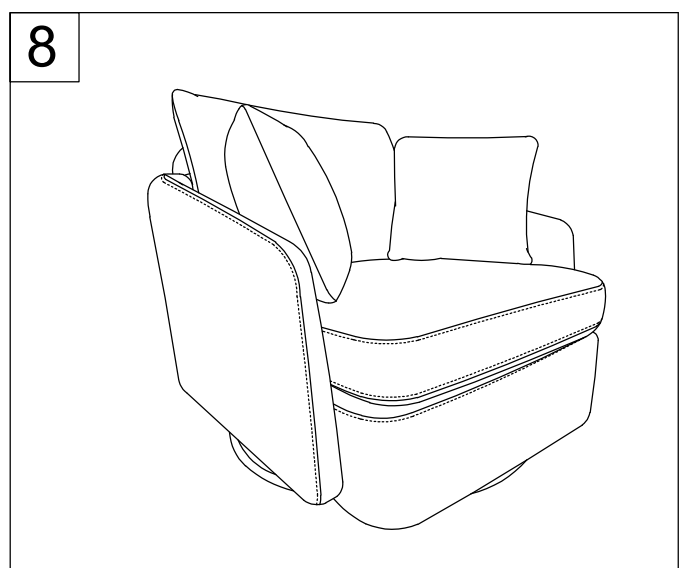
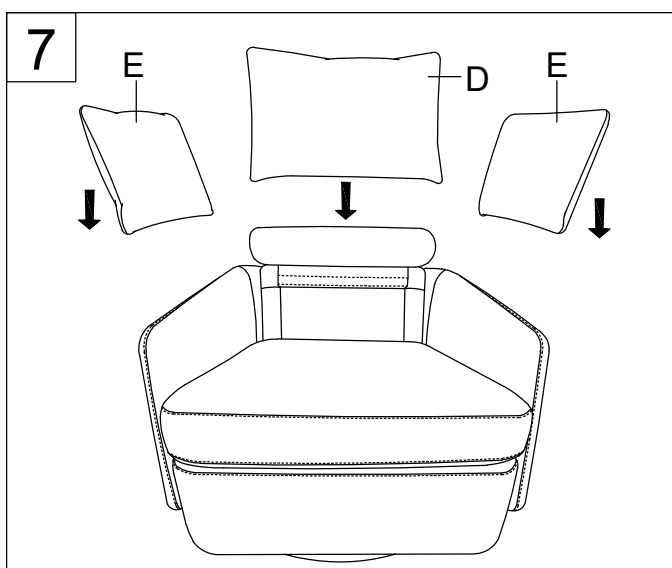
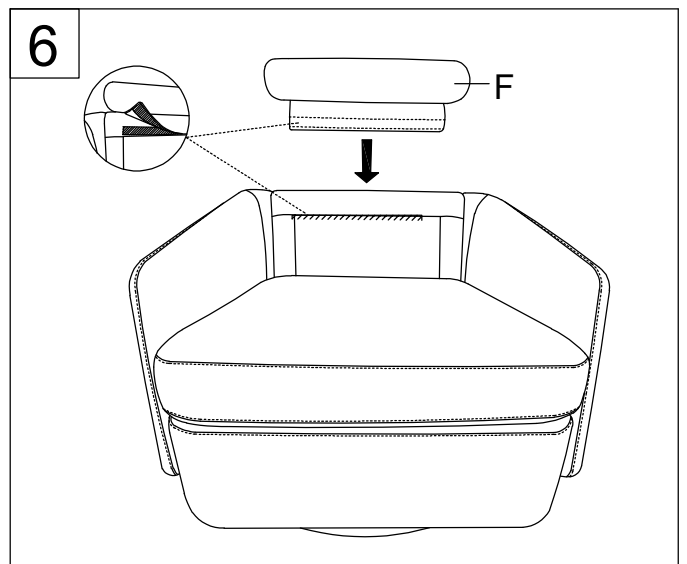
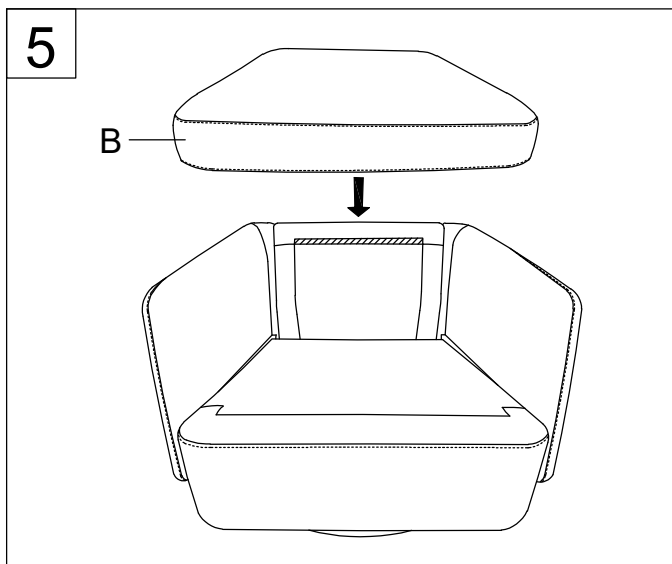
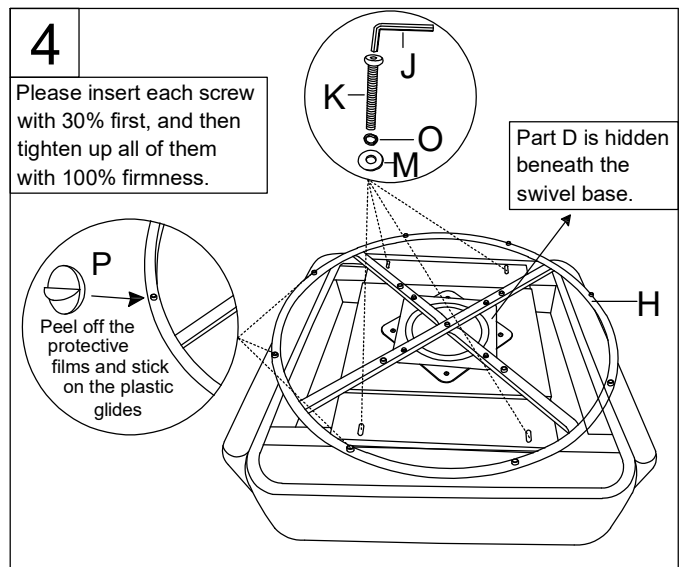
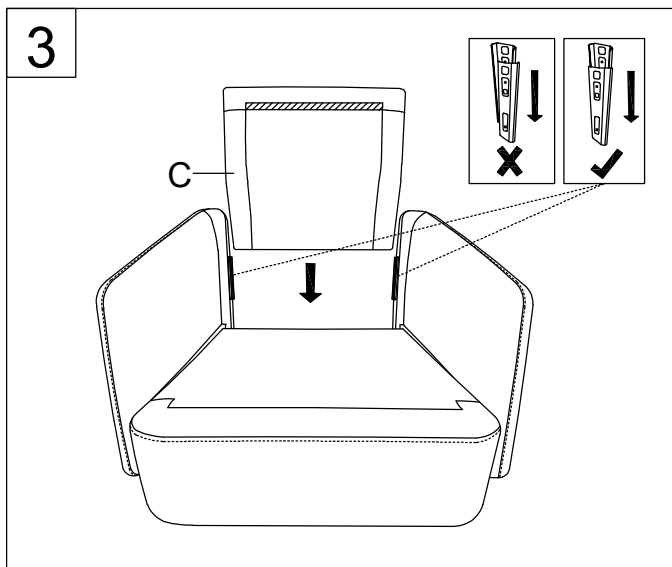

Hardware Pack Location: In the corner of inside carton.
Please don't throw away the original package if you insist to return the products.