

ROUND

ASSEMBLY GUIDE



Important - Please read these instructions fully before starting assembly



**SAFETY AND
CARE ADVICE**



NO POWER TOOLS

SAFETY AND CARE ADVICE

- Check you have all the components and tools listed.
- Remove all fittings from the plastic bags and separate them into their groups.
- We do not recommend the use of power drills/drivers for inserting screws, as this could damage the unit. Only use hand screwdrivers and Allen keys.
- Keep children and animals away from the work area, small parts could cause choking if swallowed.
- Make sure you have enough space to layout the parts before starting.
- Assemble the item as close to its final position (in the same room) as possible.
- Do not overtighten the nuts to avoid causing damage to the threads.
- Only clean using a damp cloth and mild detergent, do not use bleach or abrasive cleaners.
- From time to time check that there are no loose screws on this unit
- This product should not be discarded with household waste. Take to your local authority waste disposal centre

IMPORTANT INFORMATION



30 MINUTE
BUILD







TWO
PERSON



MAXIMUM
CAPACITY 40Kg

PLEASE CHECK CAREFULLY AND MAKE SURE YOU HAVE ALL FITTINGS AND TOOLS LISTED BELOW BEFORE YOU START.

HARDWARE LIST		
No	Description	Qty
A	JCBC BOLT 	8 PCS
B	Spring Washer 	8 PCS
C	Flat Washer 	8 PCS
D	Allen Key 	1 PC

LIST OF PARTS		
No	Description	Qty
1	Table Top	1 PC
2	Table Leg	4 PCS

NOTE: The quantities above are the correct amount to complete the assembly. In some cases more fittings may be supplied than are required.

STEP 1

Use a clean, flat, soft surface to avoid any bumps or scratches.

Place the tabletop [1] face down. Connect the 4x table legs [2].

Align the pre-drilled holes and connect each leg using 2x flat washers [C] followed by 2x spring washers [B] and 2x bolts [A] per leg. Tighten with Allen key [E].

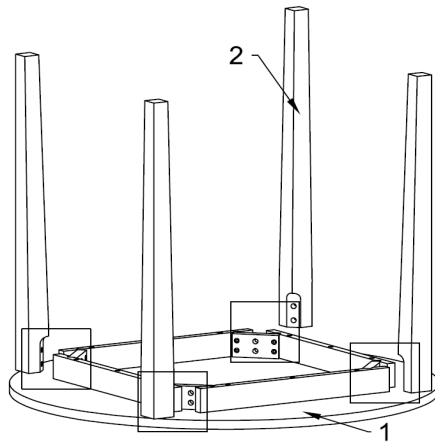
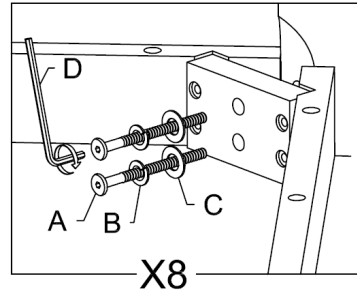

STEP 2

Carefully and with help, flip your table upright onto its legs. Check for stability. Your new table is now ready to use.

