

ASSEMBLY INSTRUCTION

WF199321-WF199322-WF199323

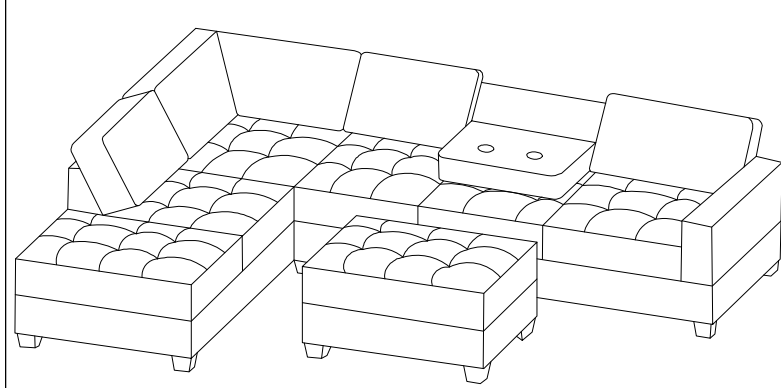

OPTION 1: CHAISE ON LEFT

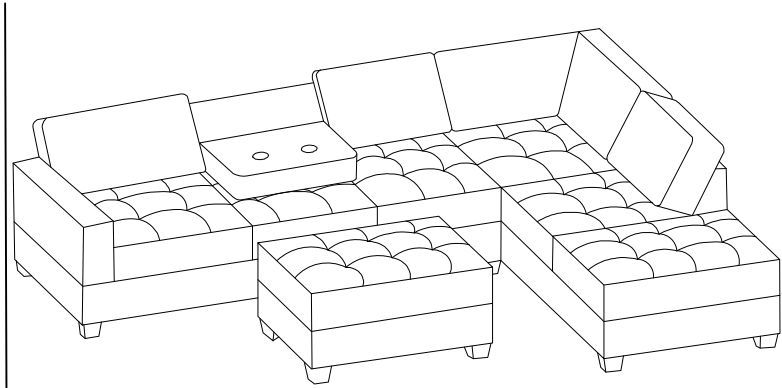

OPTION 2: CHAISE ON RIGHT

PARTS

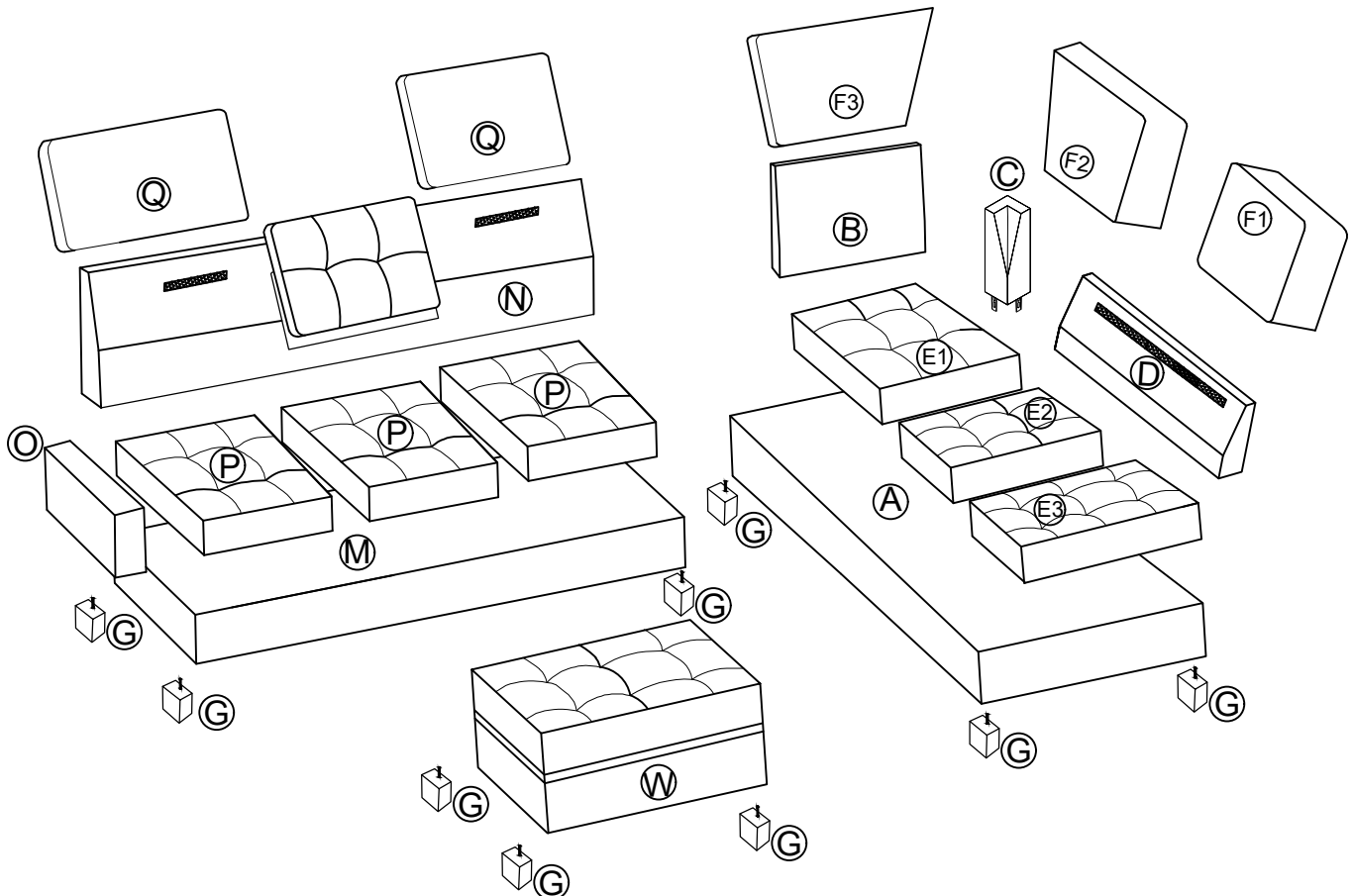

WF199322 - COMPONENT LIST

W

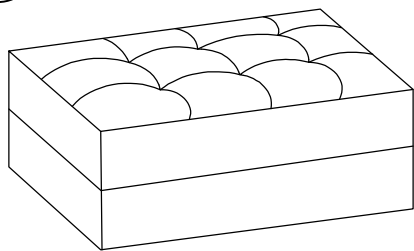

STORAGE OTTOMAN x 1

G

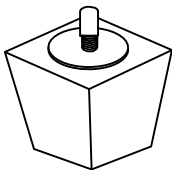

LEG x 4

WF199323 - COMPONENT LIST

A

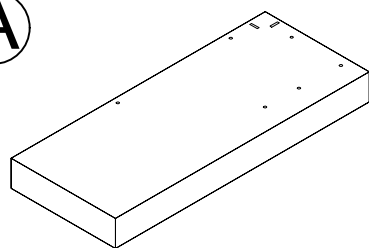

CHAISE SEAT x 1

B

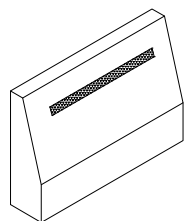

SHORT CHAISE BACK REST x 1

C

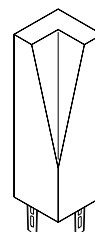

BACK CORNER x 1

D

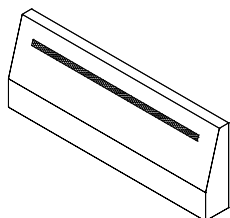

LONG CHAISE
BACK REST x 1

E1

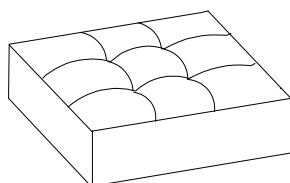

REAR SEAT CUSHION x 1

E2

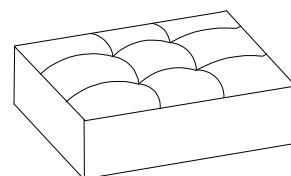

MIDDLE SEAT CUSHION x 1

E3

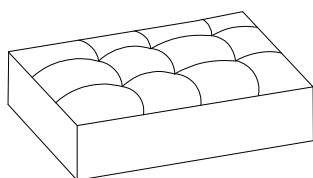

FRONT SEAT
CUSHION x 1

F1

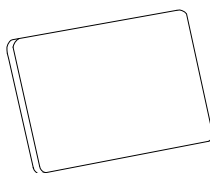

FRONT BACK
CUSHION x 1

F2

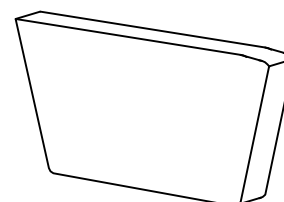

MIDDLE BACK
CUSHION x 1

F3

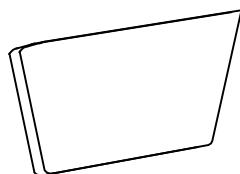

REAR BACK CUSHION x 1

G

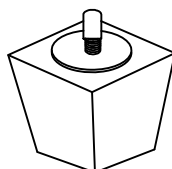

LEG x 4

WF199321 - COMPONENT LIST

(M)

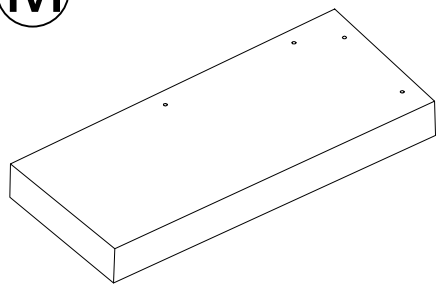

SOFA FRAME x 1

(N)

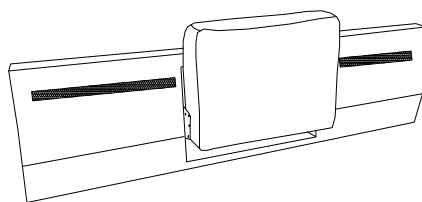

SOFA BACK REST
WITH MIDDLE BACK CUSHION x 1

(O)

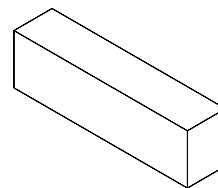

ARM x 1

(P)

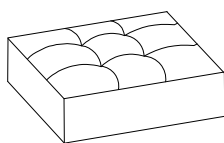

SOFA SEAT CUSHION x 3

(Q)

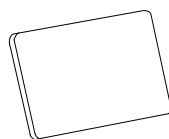

SOFA BACK CUSHION x 2

(G)

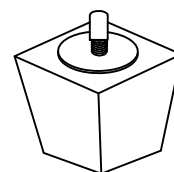

LEG x 4

HARDWARE (in box WF199321)

(H)

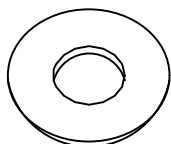

FLAT WASHER
Ø5/16" x 22MM
9PCS

(I)

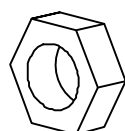

HEX NUT
Ø5/16" x 12MM
9PCS

(J)



BOLT
Ø5/16" x 90MM
9PCS

(K)

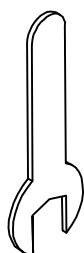

OPEN WRENCH
1PC

(L)

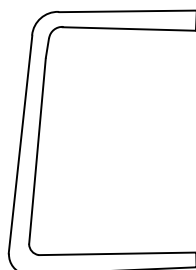

METAL CONNECTOR
2PCS

Step 1:

Remove the hardware and the leg box from packet.

Place all parts on a clean, smooth surface

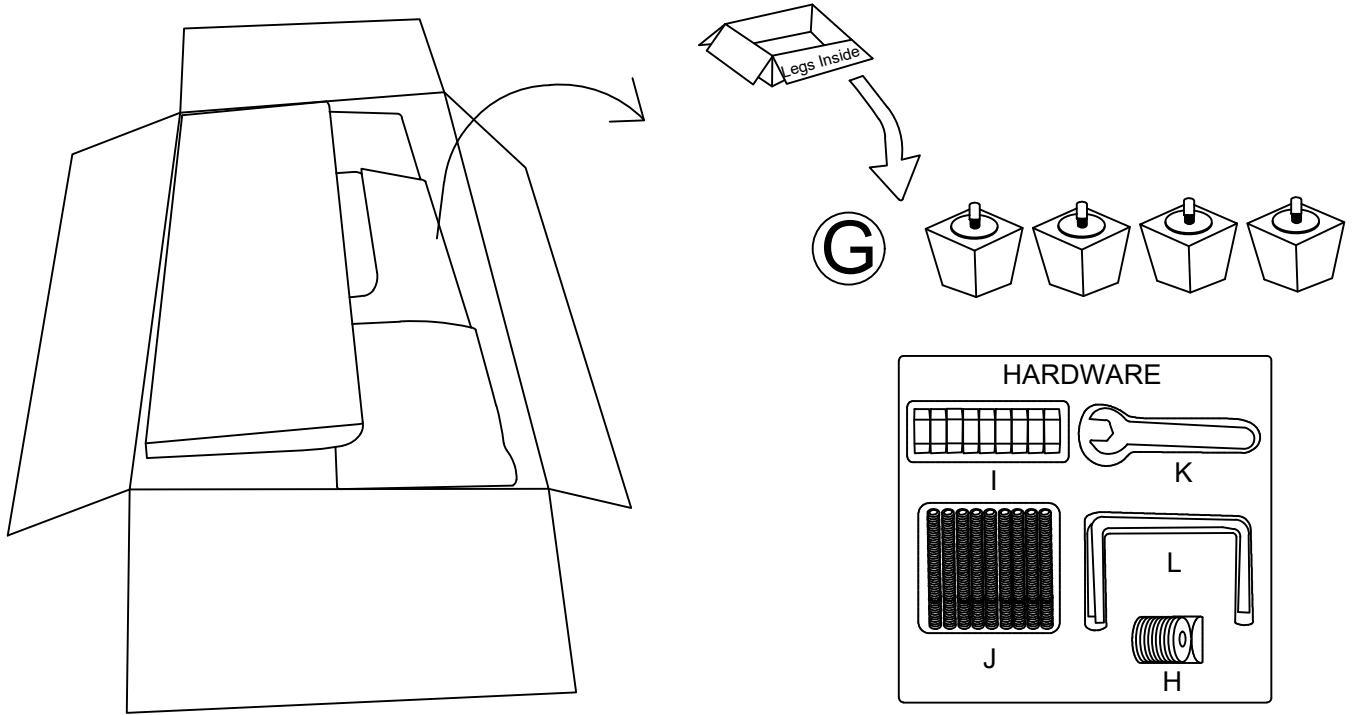

Step 2:

Manually screw J to B and D as shown.

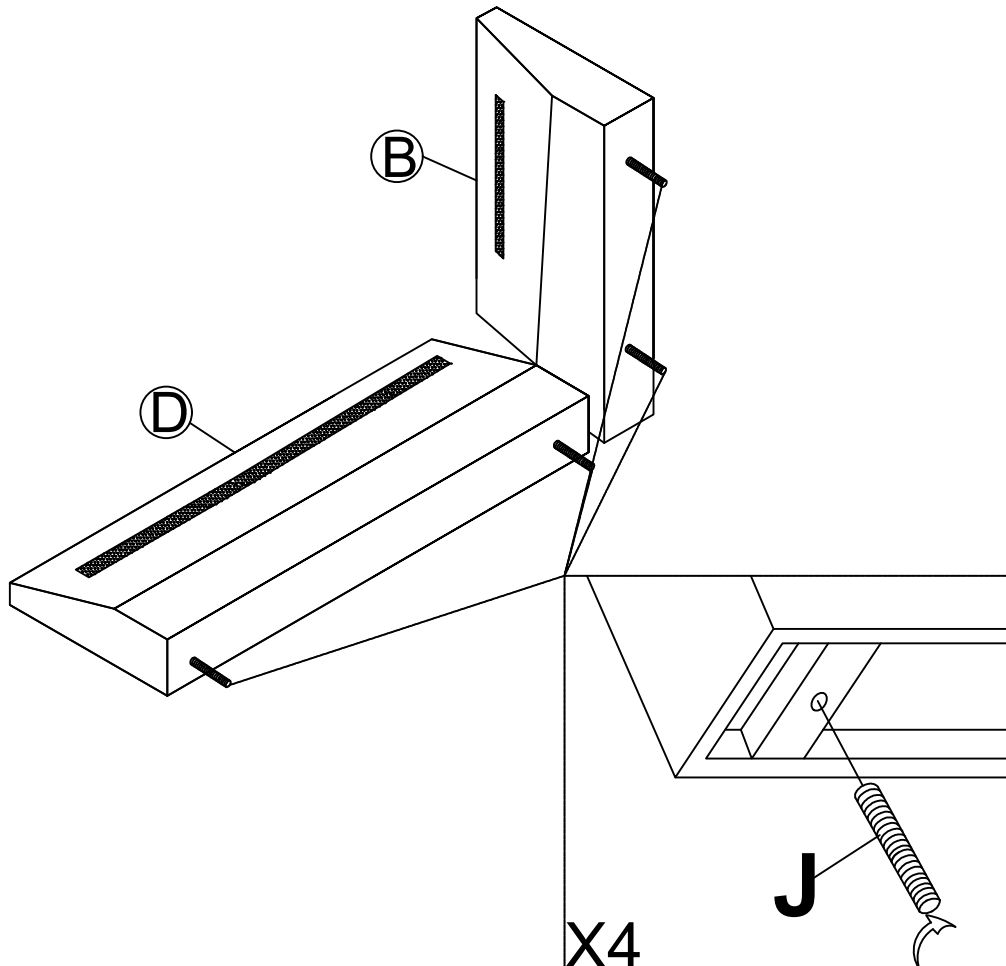

Step 3:

Insert part C to the hole in A.

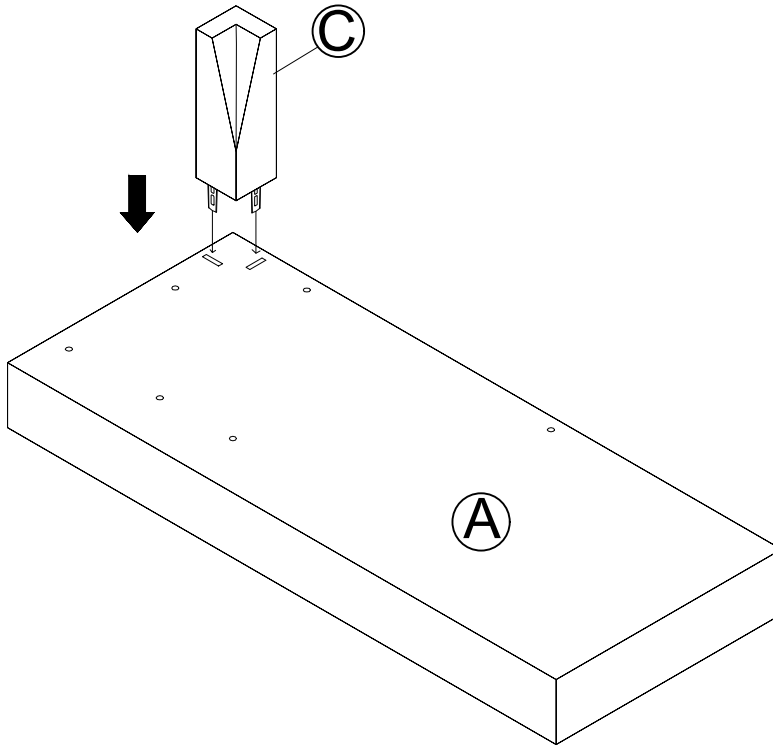

Step 4:

Align the backrest D and B with the hole in A. Fix it by using H&I

Option 1

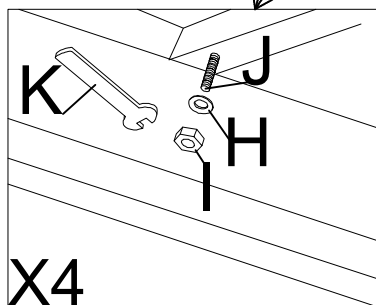
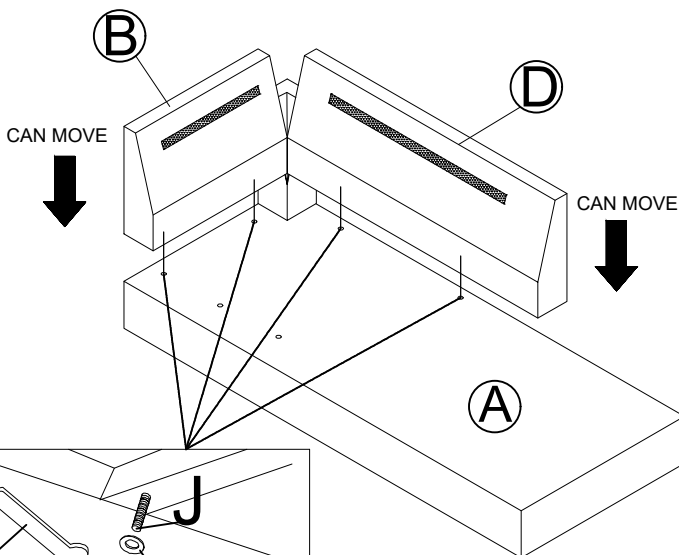

Option 2

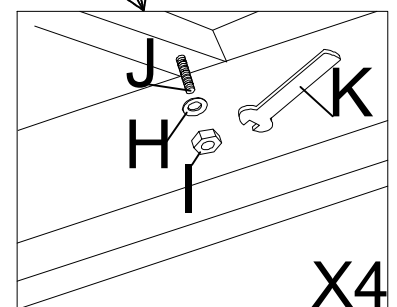
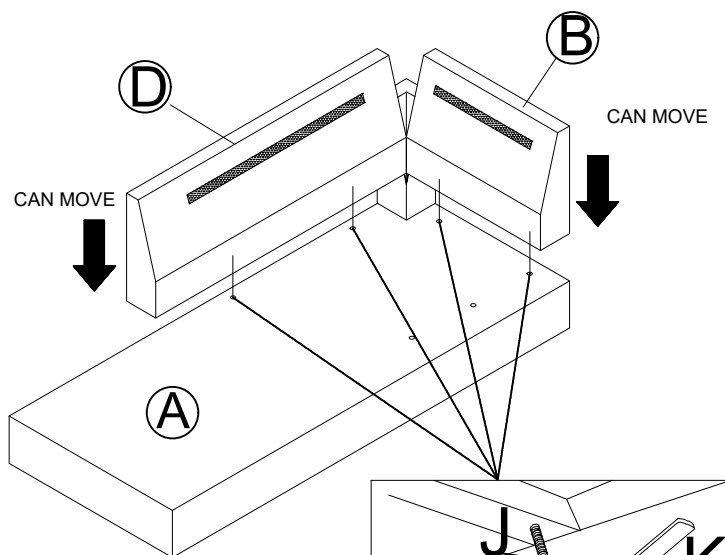

Step 5:

Manually legs G x 4 to A , as shown

▲ Please remove the protective cap on the tip of thread before assembling.

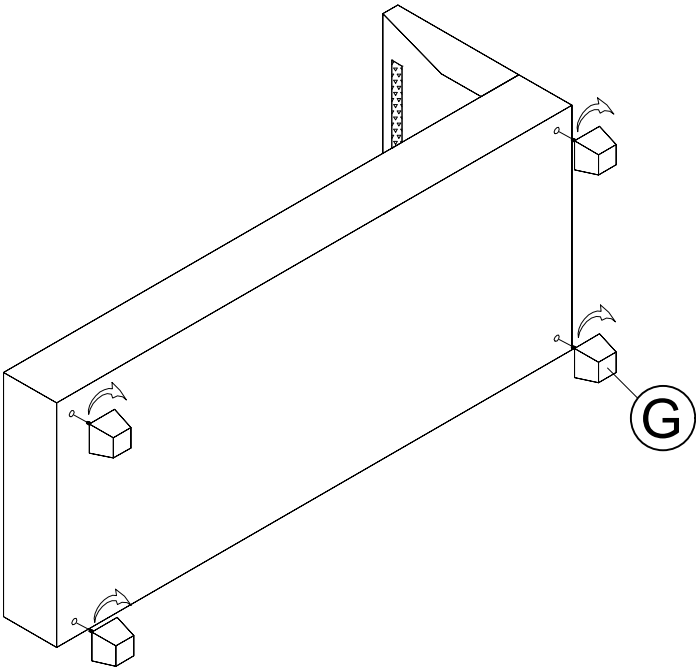
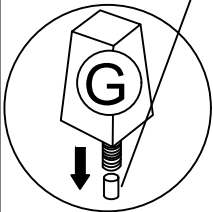

BOTTOM VIEW

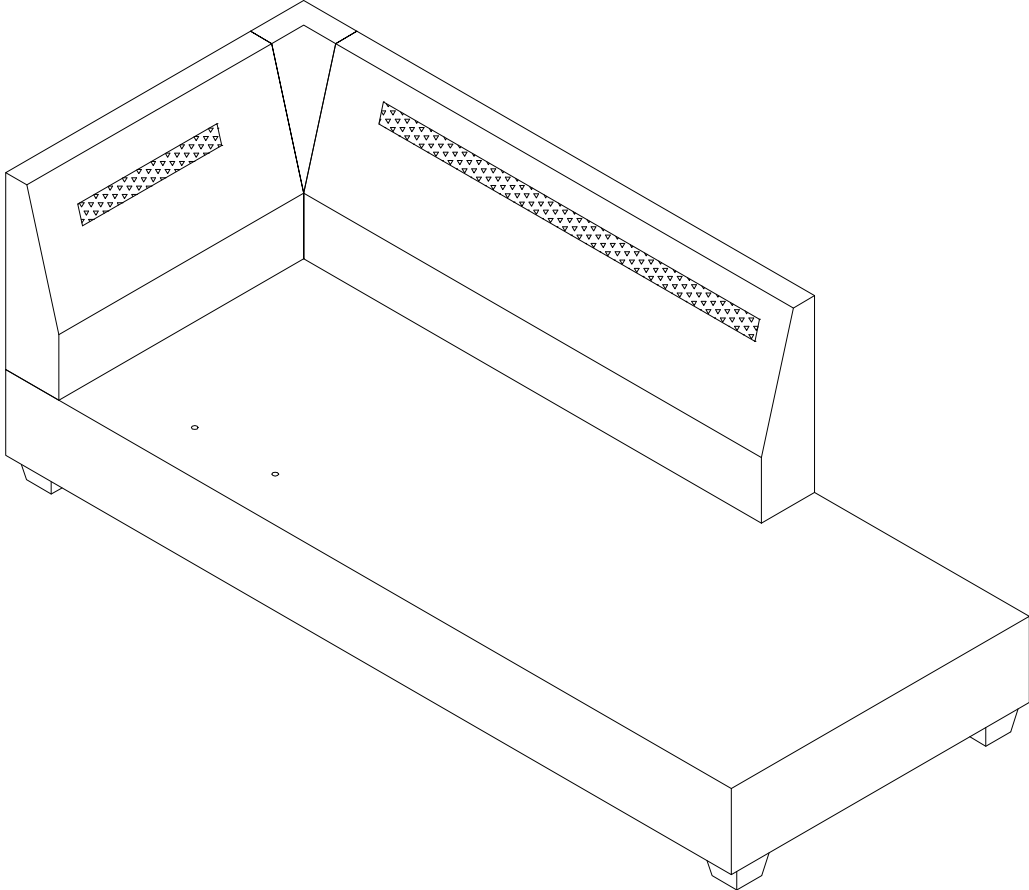

Step 6:

Manually screw J to N and O as shown.

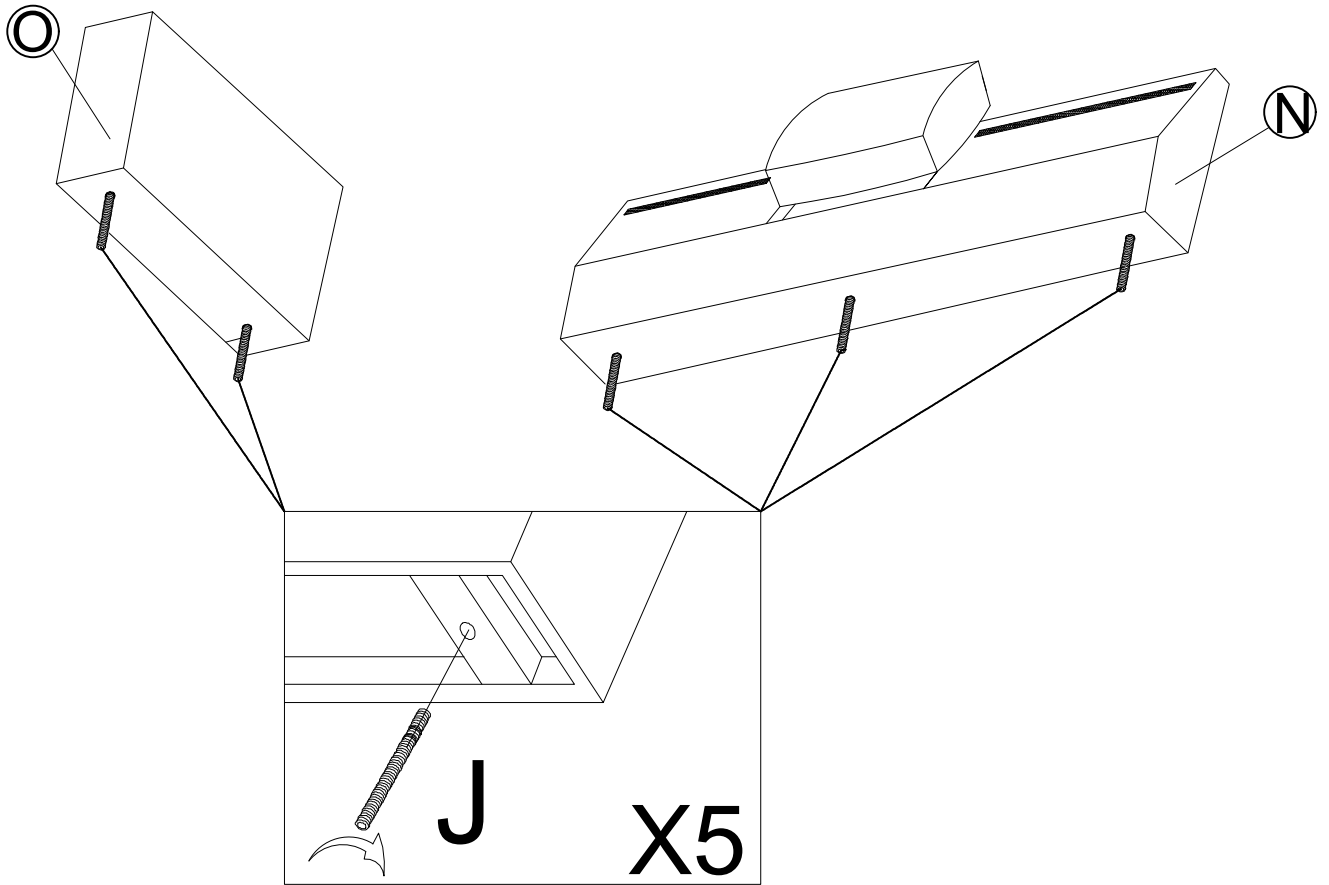

Step 7:

Align the backrest O and N with the hole in M. Fix it by using H & I.

Option 1

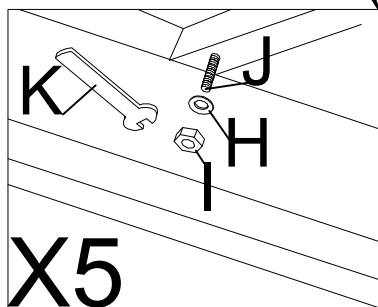
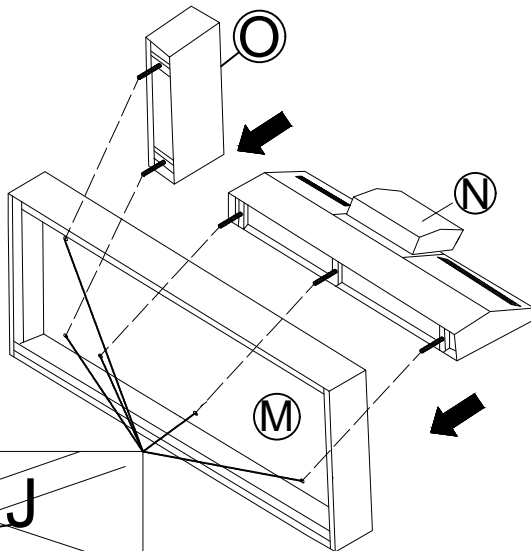

Option 2

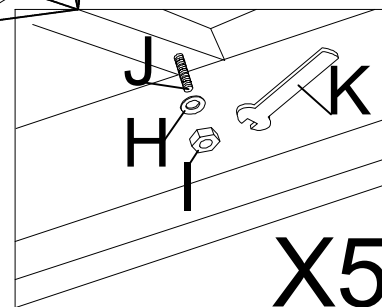
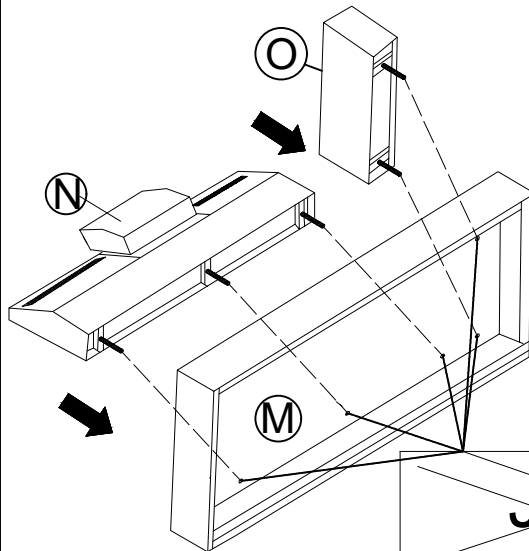

Step 8:

Manually legs G x 4 to M , as shown

▲ Please remove the protective cap on the tip of thread before assembling.

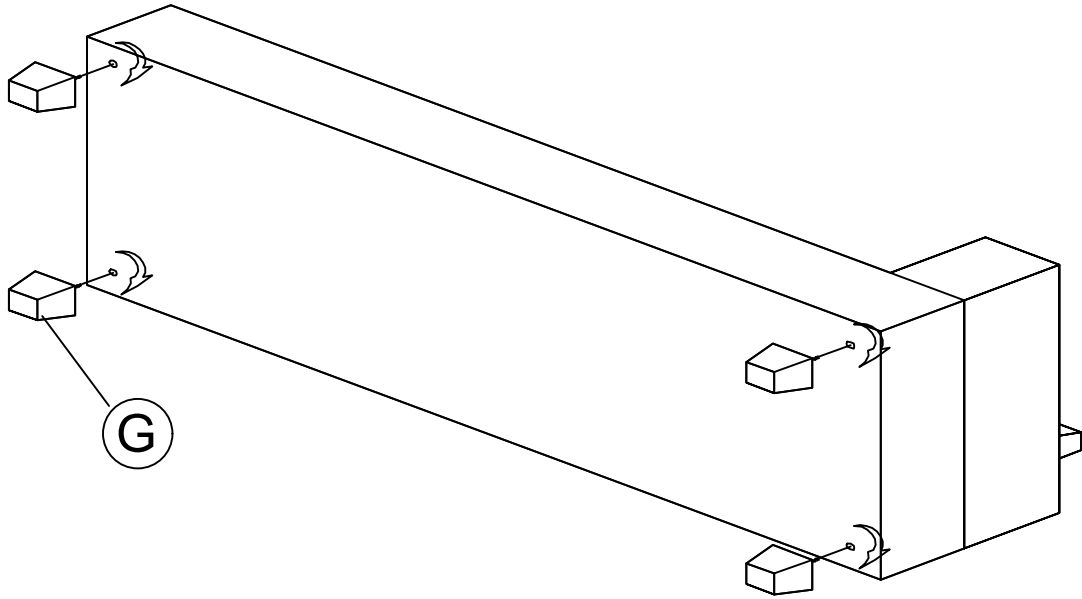
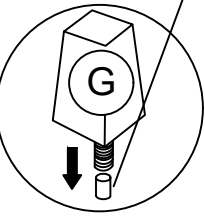

BOTTOM VIEW

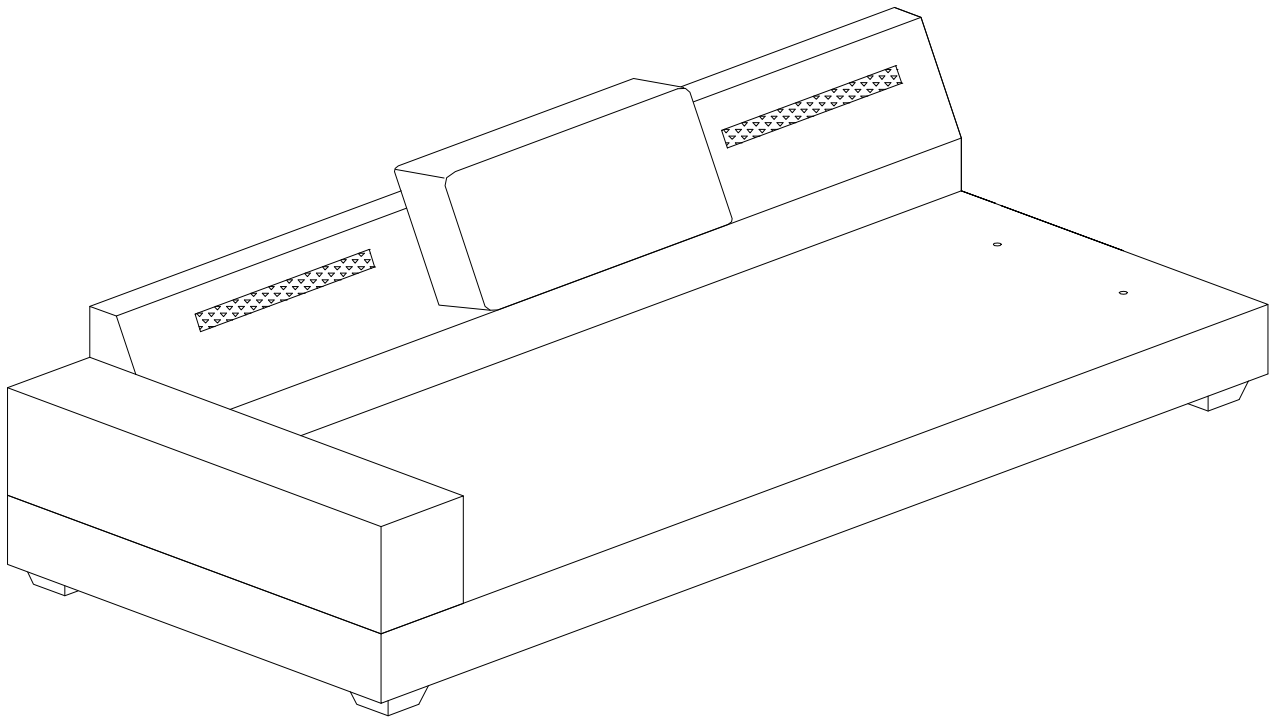

Step 9:

Insert the U-shaped part P into the hole to fix base.

Option 1

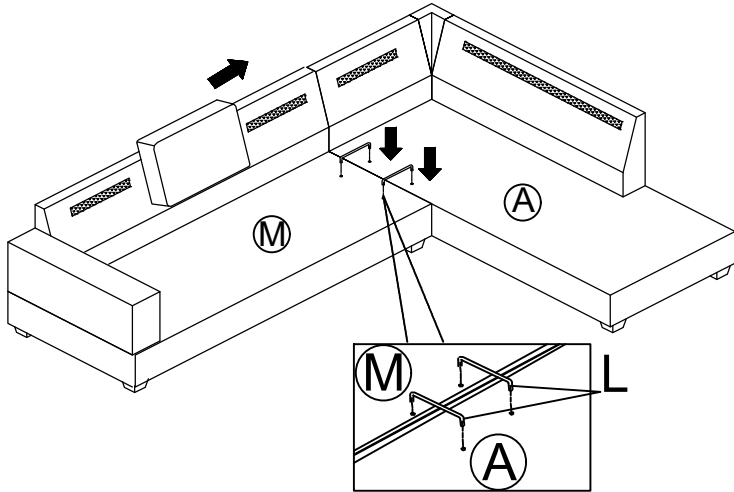

Option 2

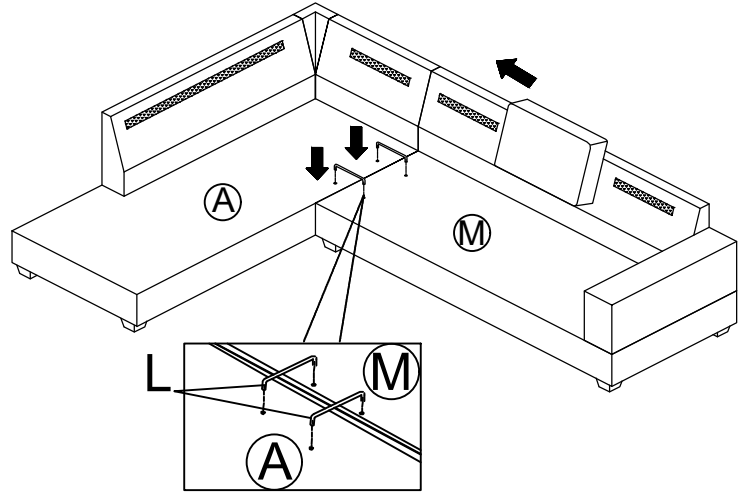

Step 10:

Remove seat cushion from their package
Place E3x1, E2x1, E1x1 and Px3 onto the sofa.

Option 1

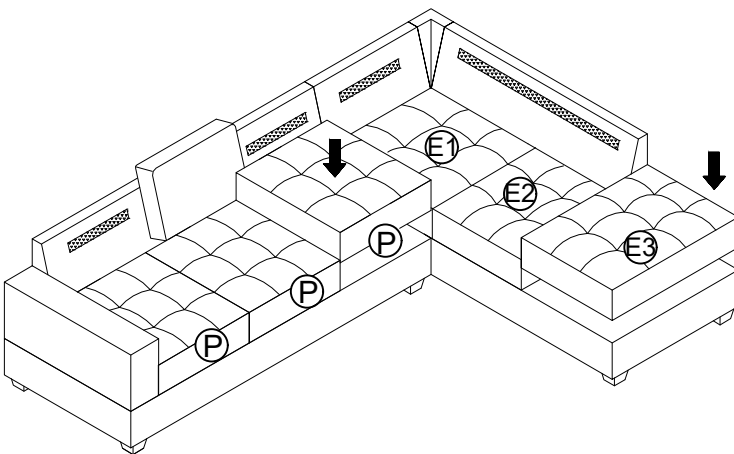

Option 2

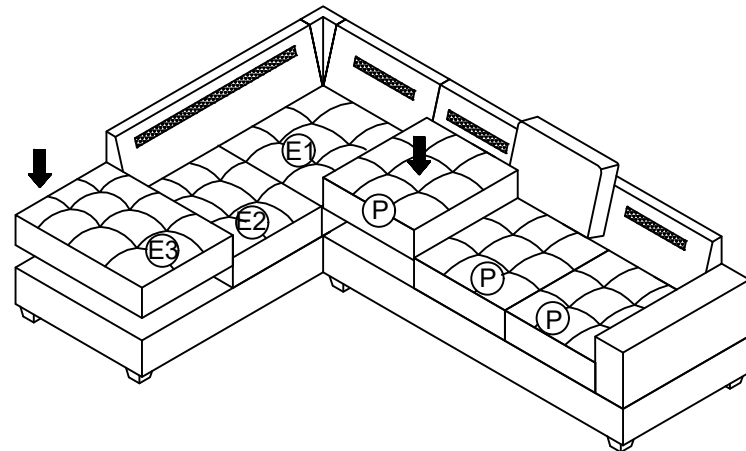

Tips: Stretch, pull down and pat seat cushions and back cushions to return nature shape and state.

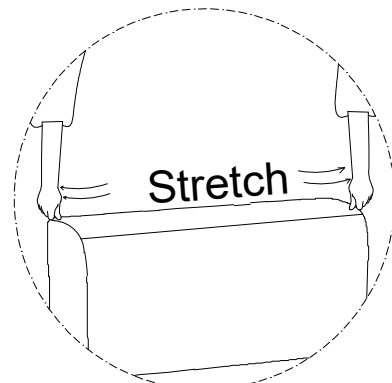
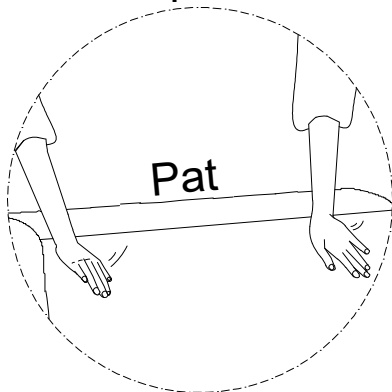

Step 11:

Remove back cushion from their package
Place F1x1, F2x1, F3x1, and Qx2 onto the sofa.

Option 1

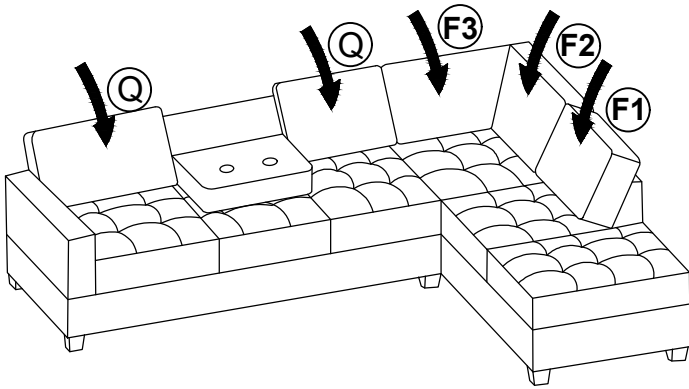

Option 2

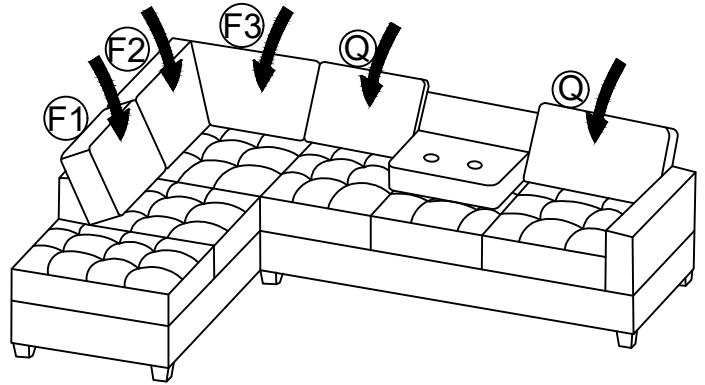

Step 12:

Manually legs G x 4 to W, as shown.

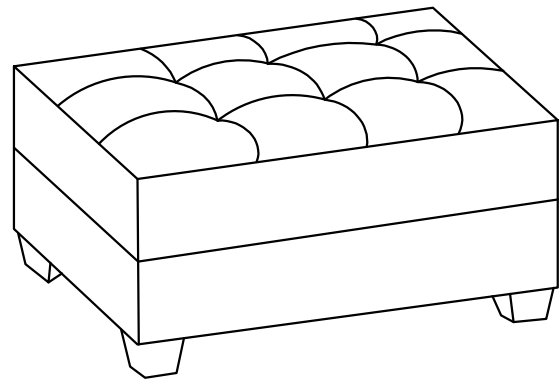
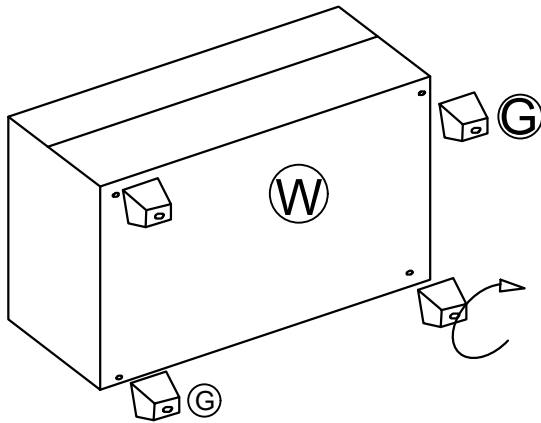

Assembly Completed !

THE CONSOLE PIECE CAN BE DROPPED DOWN AND TURN INTO AN ARMREST PANEL WITH CUP HOLDERS

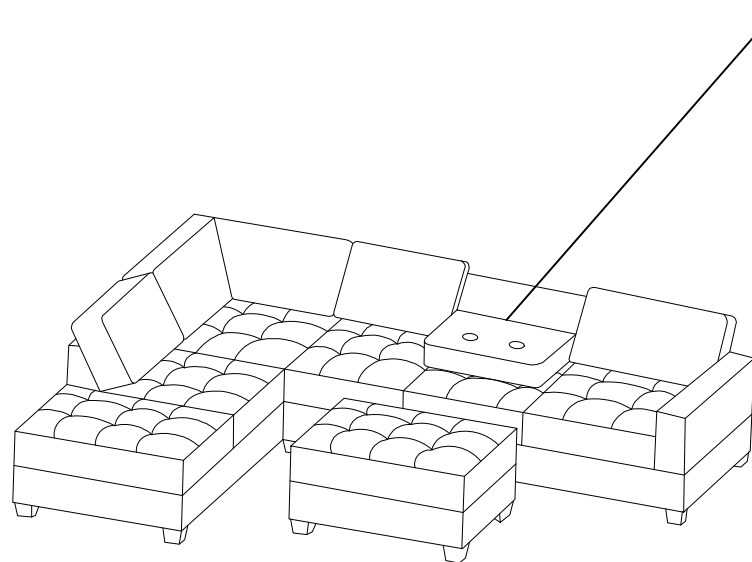

OPTION 1: CHAISE ON LEFT

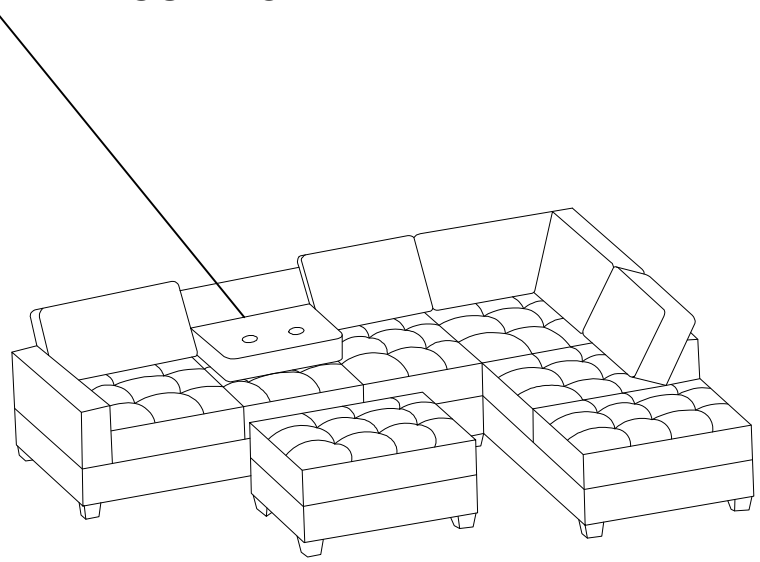

OPTION 2: CHAISE ON RIGHT