

# Bar Stool







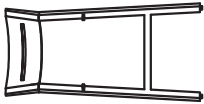

## ASSEMBLY INSTRUCTIONS

OE-H-575

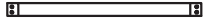

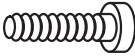
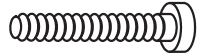
### BEFORE ASSEMBLY:

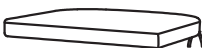
- Please read these instructions carefully before starting assembly. We suggest you carry out the assembly on a soft surface like a carpet, so as to avoid scratching the paint. Keep children away during assembly. This item contains small parts which can be swallowed by children.
- This product was made for the explicit purpose of providing outdoor function and is not to be used as a toy. This product is for residential use only. This product is NOT intended for commercial use; unintended use will void the warranty.
- This product is not intended for use during inclement or severe weather, that includes but is not limited to rain, hail, sleet, snow, wind, freezing conditions and extreme heat.
- Please note because of the nature of cast metal, you may find roughness on the surface which enhances the beauty of the product and is not a defect.
- Aluminum is soft metal, please do not use power tools, and over tighten may strip threads or break the parts.
- When not in use, store and/or cover the product in a cool dry location. Do not locate the product near any sort of high heat. Do not use the product as a support.
- Children under the age of 10, who are near the product, should be supervised by a competent adult at all times.
- Do not discard any of packaging until you finish the assembly. Keep the assembly instructions for future reference or warranty.

<p>AX2</p>  <p>Back</p>	<p>BX2</p>  <p>Seat</p>	<p>CX2</p>  <p>Front Leg</p>	<p>DX2</p>  <p>Support Bar</p>
<p>EX20</p>  <p>Spring Washer</p>	<p>FX20</p>  <p>Washer</p>	<p>GX12</p>  <p>Bolt(M6*20)</p>	<p>HX8</p>  <p>Bolt(M6*25)</p>
<p>IX20</p>  <p>Bolt Cap</p>	<p>JX2</p>  <p>Cushion</p>	<p>KX2</p>  <p>Allen Wrench</p>	

**Step 1:** Place all the parts on a clean and soft surface, identify all the parts and hardware kits against parts list. Assemble Front Leg(C) and Seat(B) with parts(E,F,G,I)&parts(E,F,H,I)in the order displayed in Fig(1).Remember not to tighten all the bolts before they are all set up.

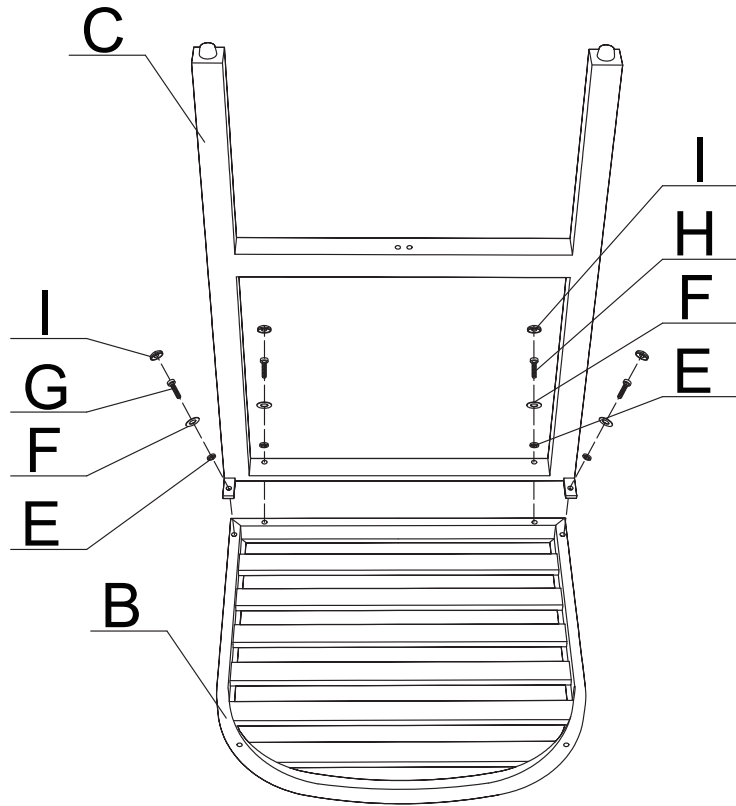

(1)

**Step 2:** Assemble Back(A) and Seat(B) with parts(parts(E,F,H,I))in the order displayed in Fig(2).Remember not to tighten all the bolts before they are all set up.

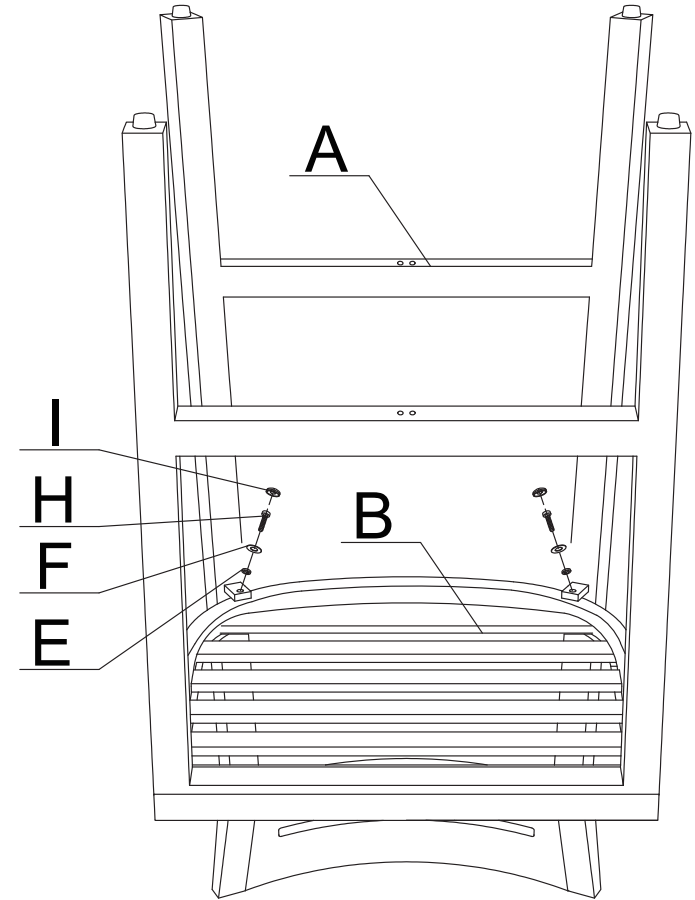

(2)

**Step 3:** Assemble Support Bar(D) between Back(A) and Front Leg(C) with parts(E,F,G,I) in the order displayed in Fig(3). Remember not to tighten all the bolts before they are all set up.

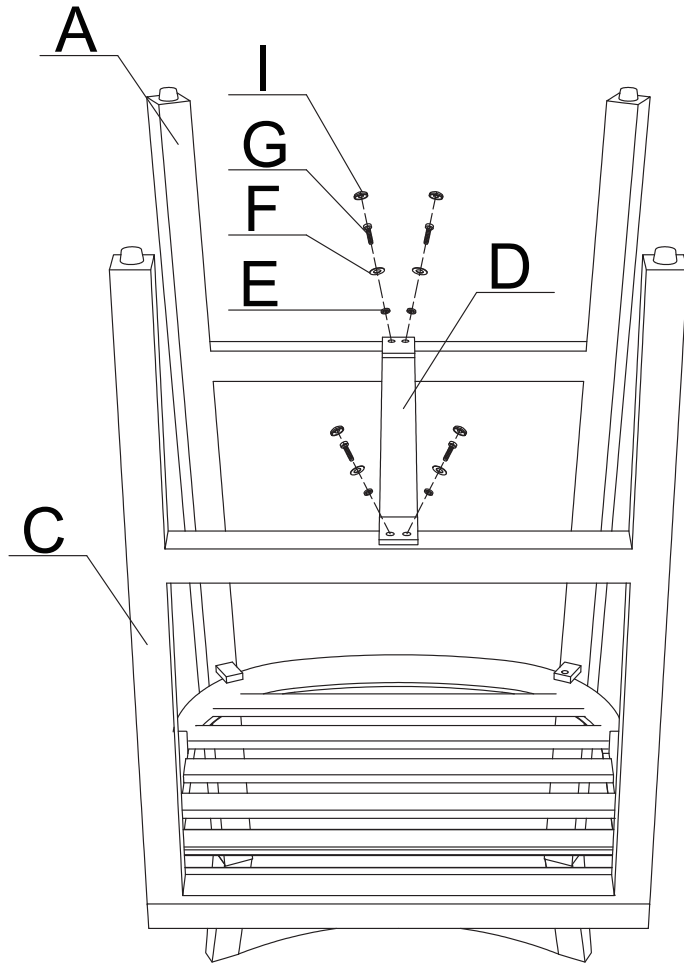

(3)

**Step 4:** Tighten all the bolts with Allen Wrench(K). Do not over tighten bolts, it will cause the damage of product without warranty. Then tie the Cushion(J) to the chair . Adjust the levelers till the chair is stable. Your chair should be ready for use.

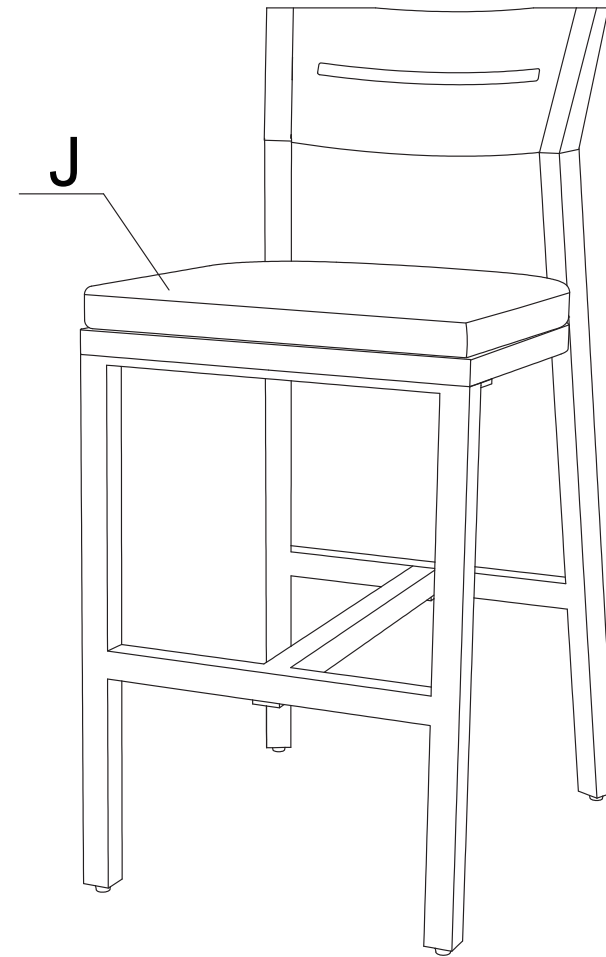

(4)