

IMPORTANT

Carefully remove all the parts from the carton and place them individually on a soft cloth to prevent scratches or other damage.

Carefully and strictly follow these assembly instructions to ensure a completed product as designed.

Do not use power tools above 8 volts to assemble.

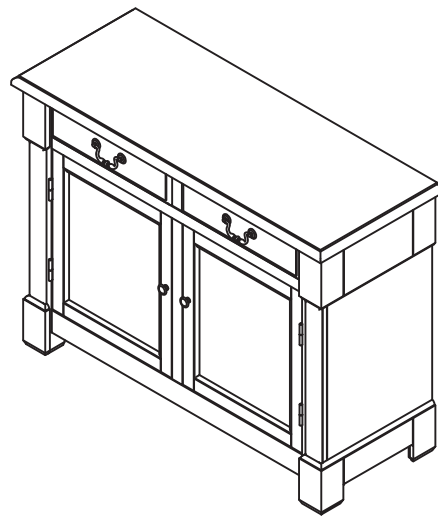

Part List

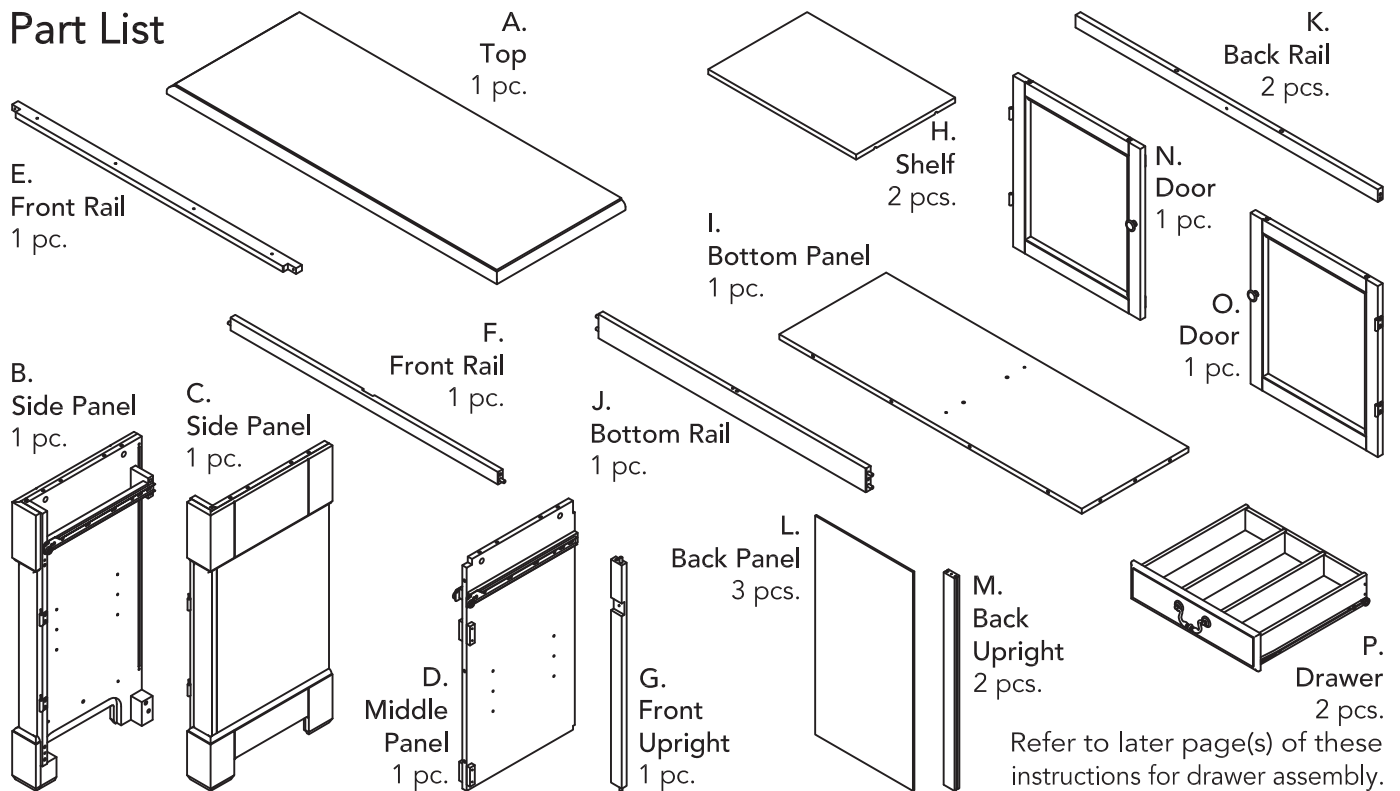

Hardware List

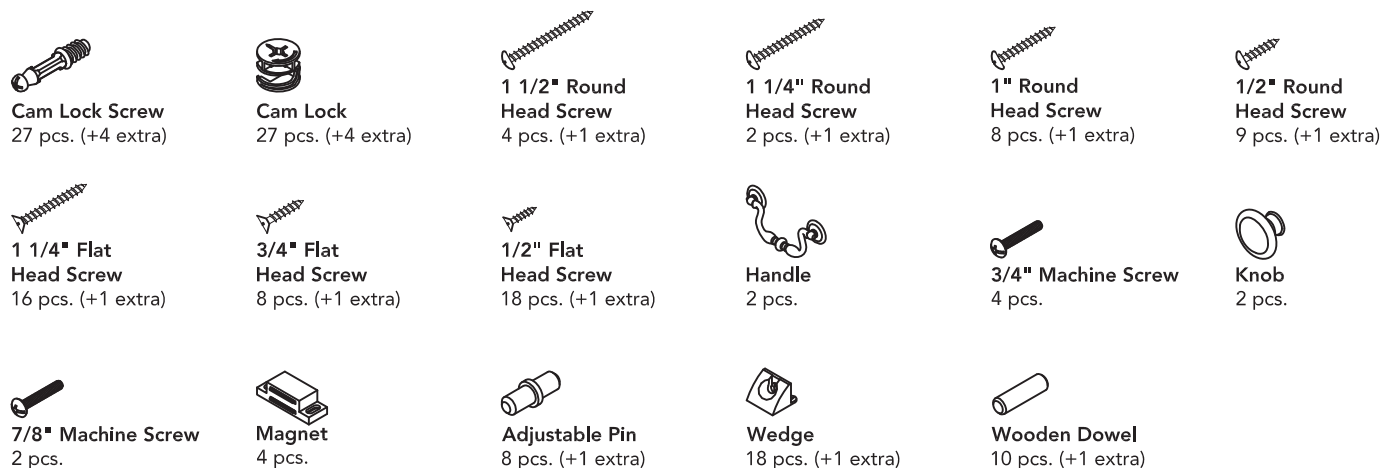

Tool(s) required for assembly: Phillips screwdriver, Level, Pencil, Drill (8 volts or less), 3/8" Drill Bit

Assembly Instructions 2/13

IMPORTANT

- Use a soft cloth between these parts and the floor.
- Do not use power tools above 8 volts to assemble.
- Do not tighten all the bolts until each part is properly assembled.
- The unit must be level to work properly. Use the included adjustable levelers to level.

STEP 1

Insert Cam Lock Screws into pre-drilled holes in Top (A), Side Panels (B), (C), Front Rail (E), Front Upright (G) and Bottom Rail (J), then tighten.

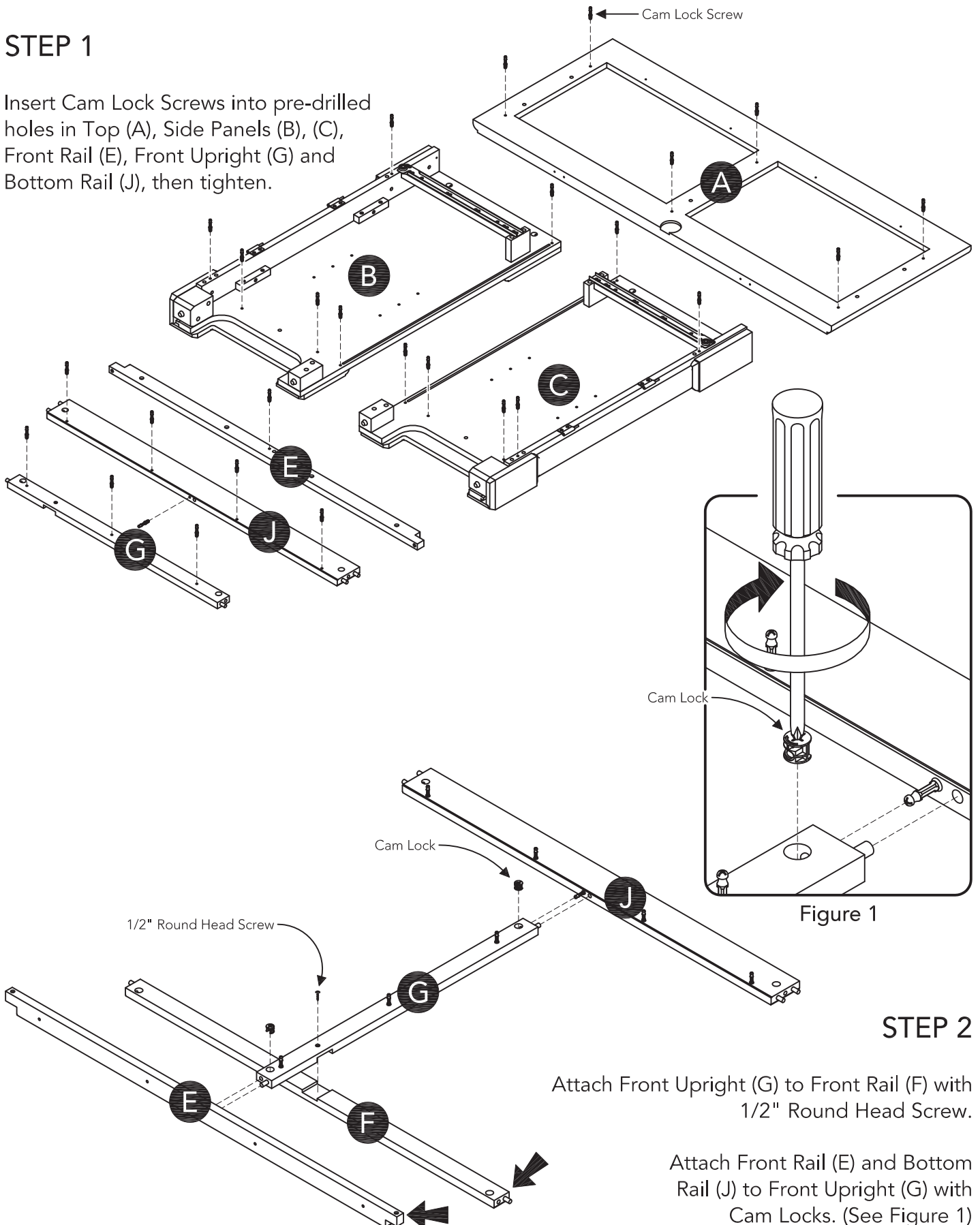

STEP 2

Attach Front Upright (G) to Front Rail (F) with 1/2" Round Head Screw.

Attach Front Rail (E) and Bottom Rail (J) to Front Upright (G) with Cam Locks. (See Figure 1)

Assembly Instructions 3/13

STEP 3

Attach Magnets to Middle Panel (D) with 1/2" Round Head Screws.
(See Figure 2)

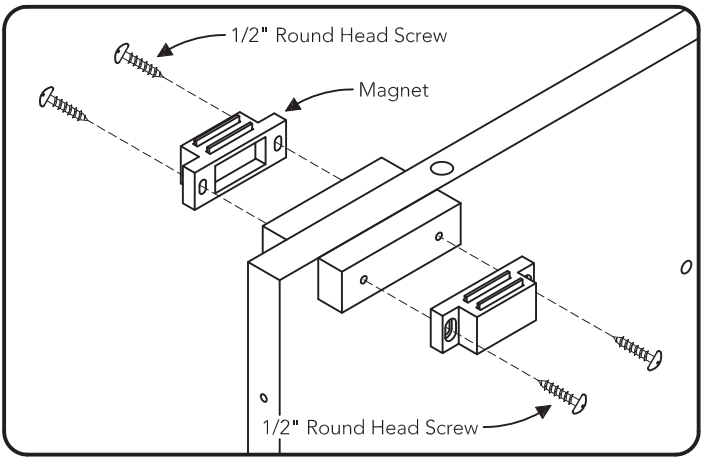
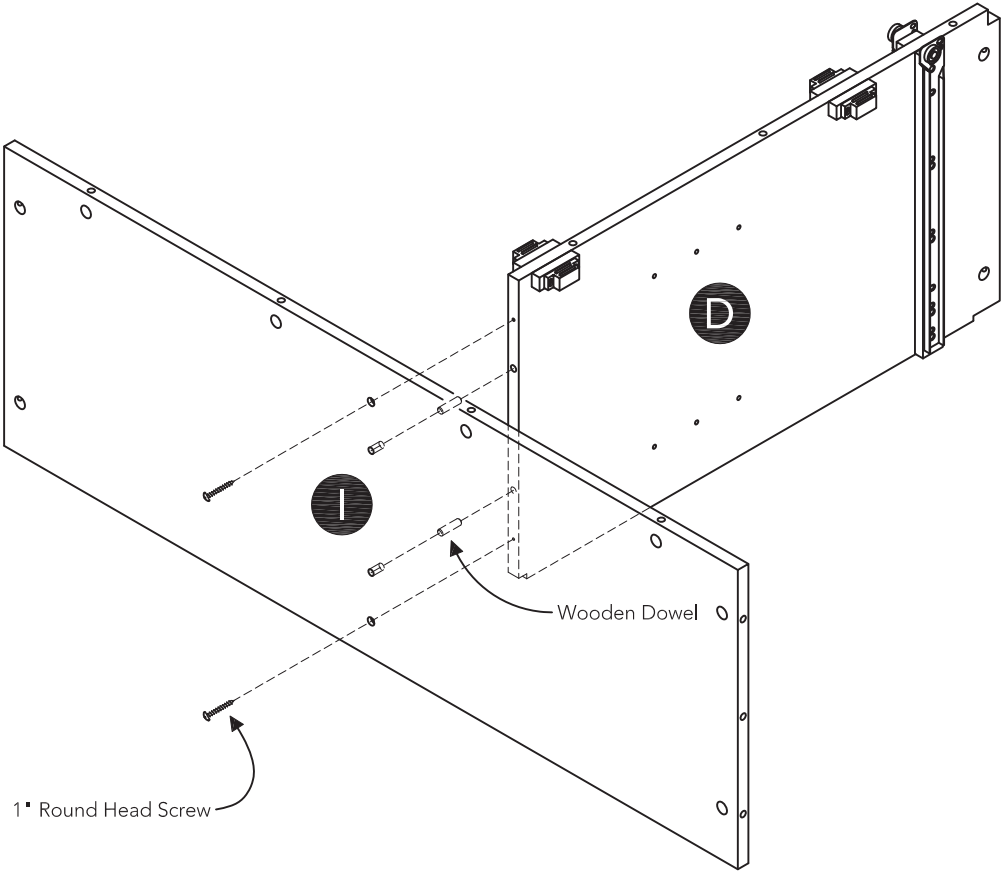
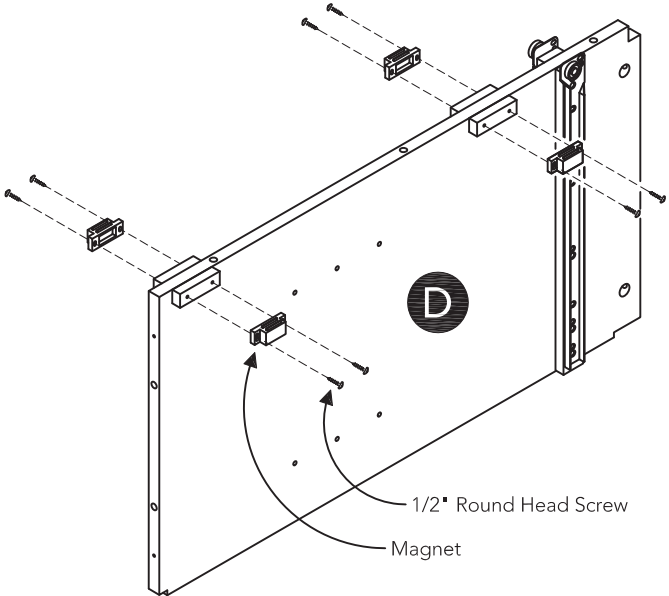

Figure 2



STEP 4

Attach Middle Panel (D) to Bottom Panel (I) with 1" Round Head Screws and Wooden Dowels.

Assembly Instructions 4/13

STEP 5

Attach unit from Step 2 to unit from Step 4 with Cam Locks.

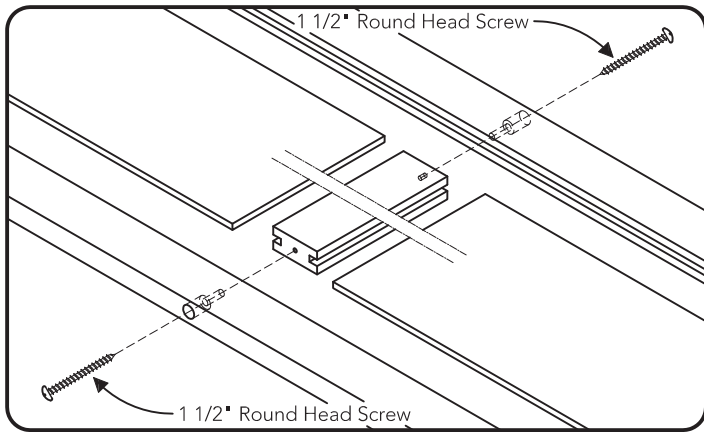
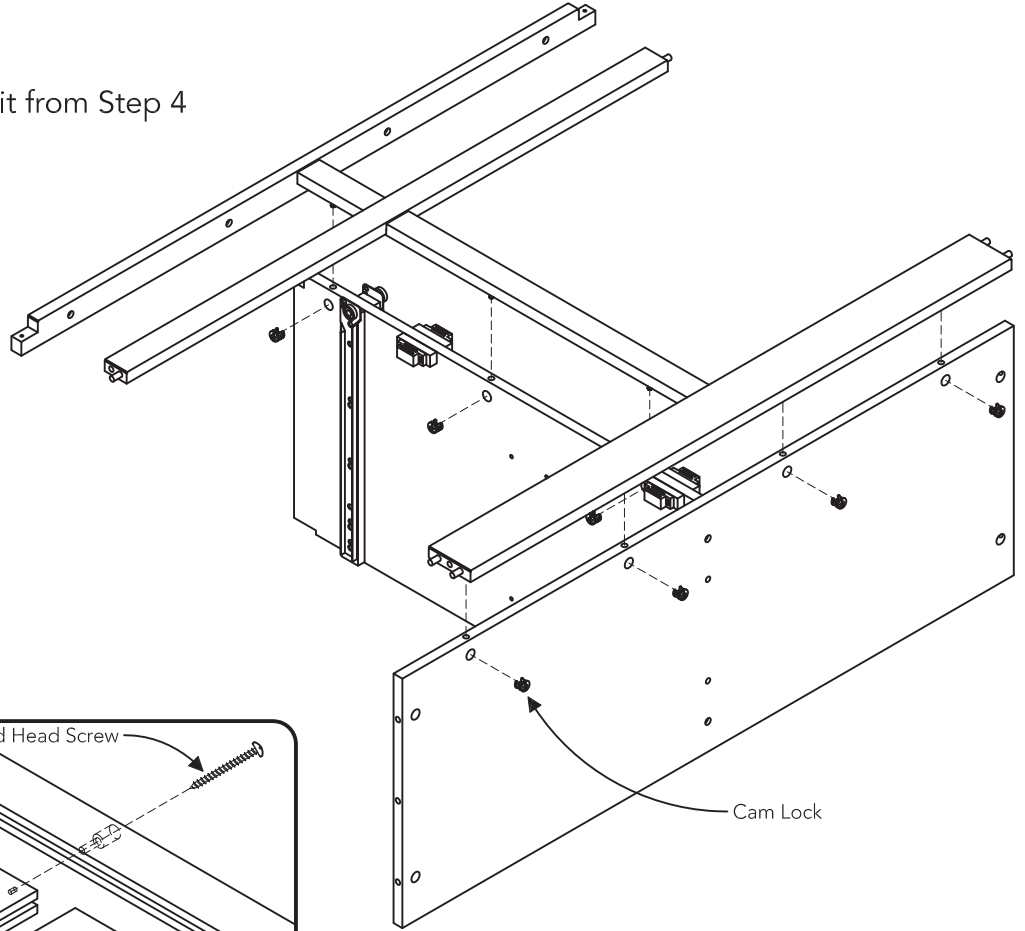
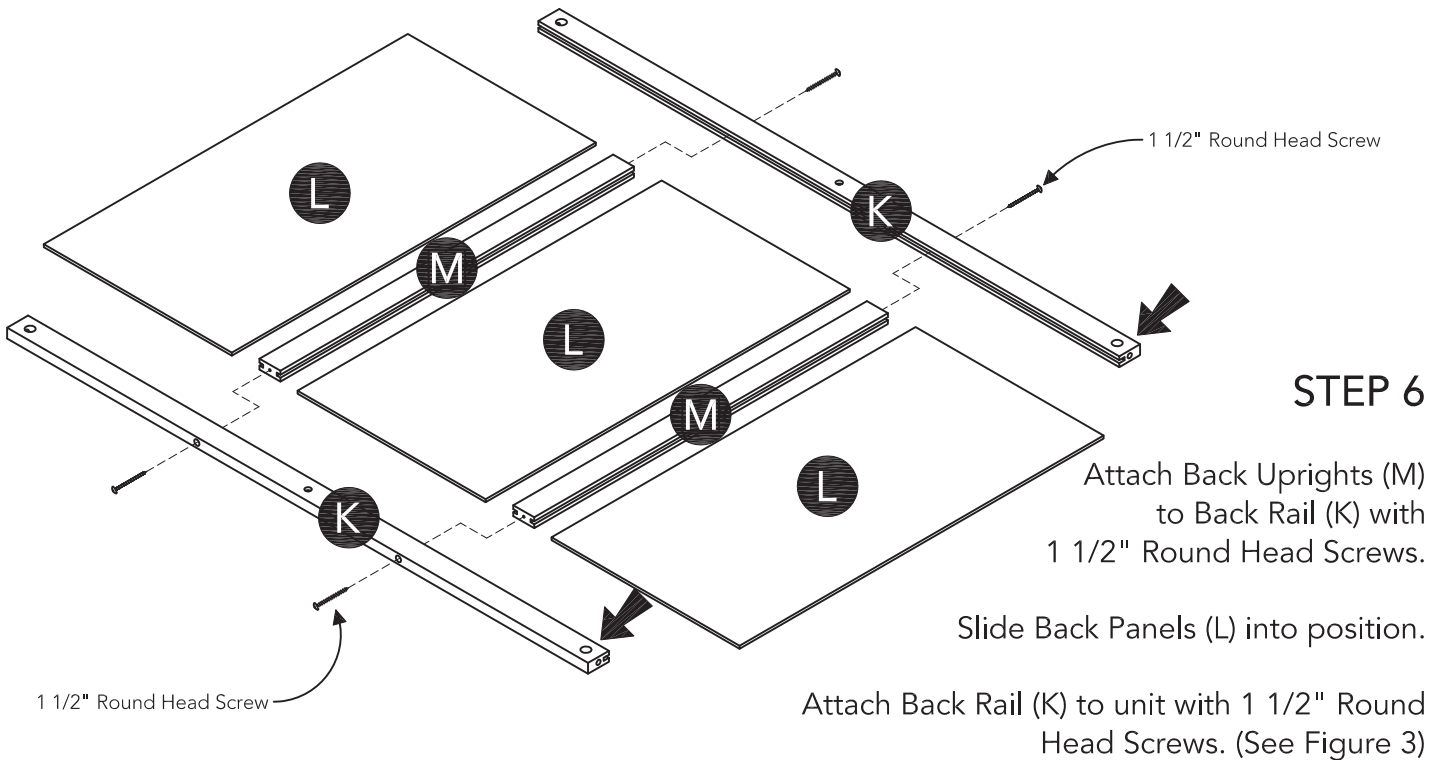

Figure 3



Assembly Instructions 5/13

STEP 7

Attach unit from Step 6 to unit from Step 5 with 1" Round Head Screws.

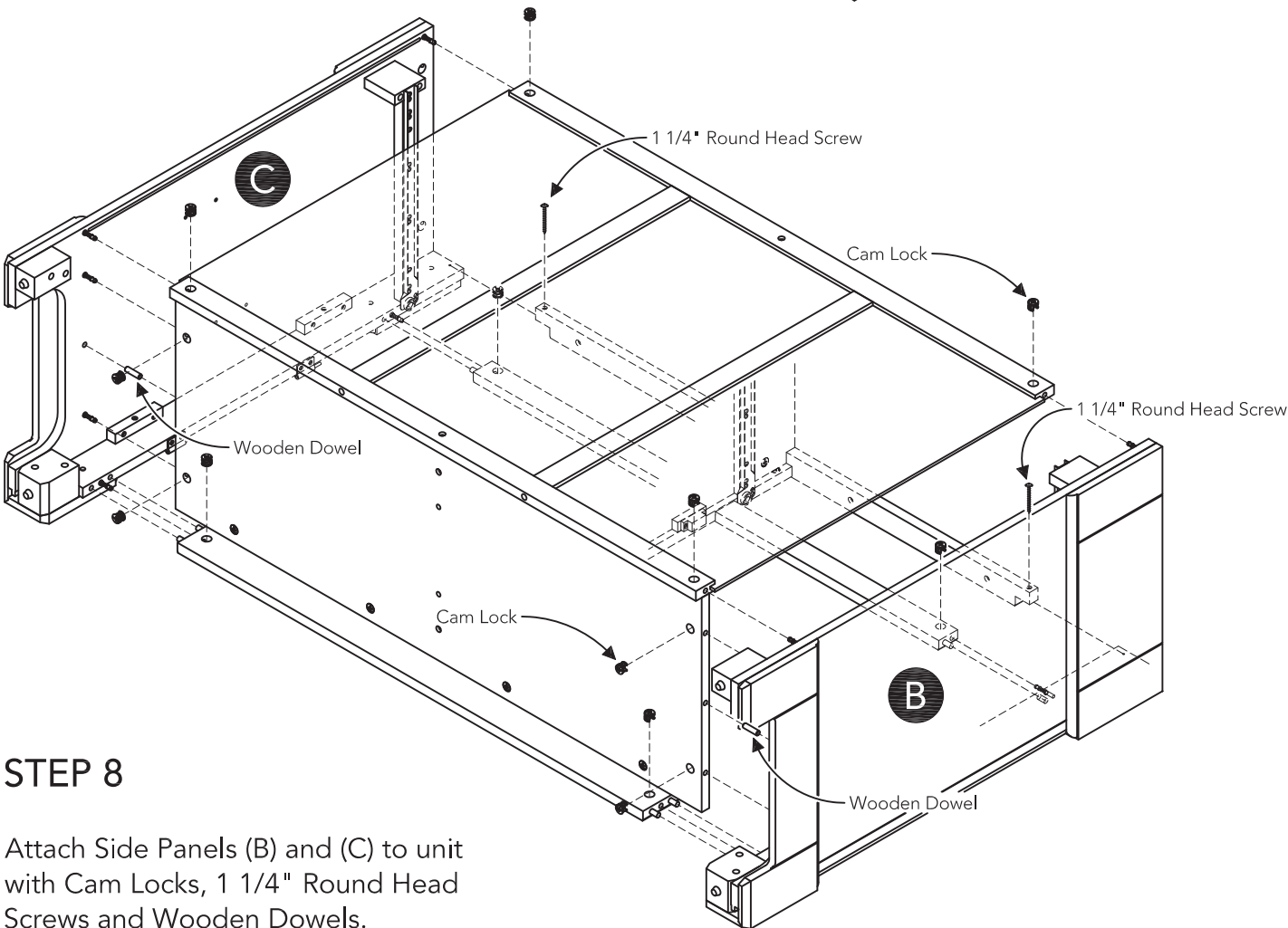
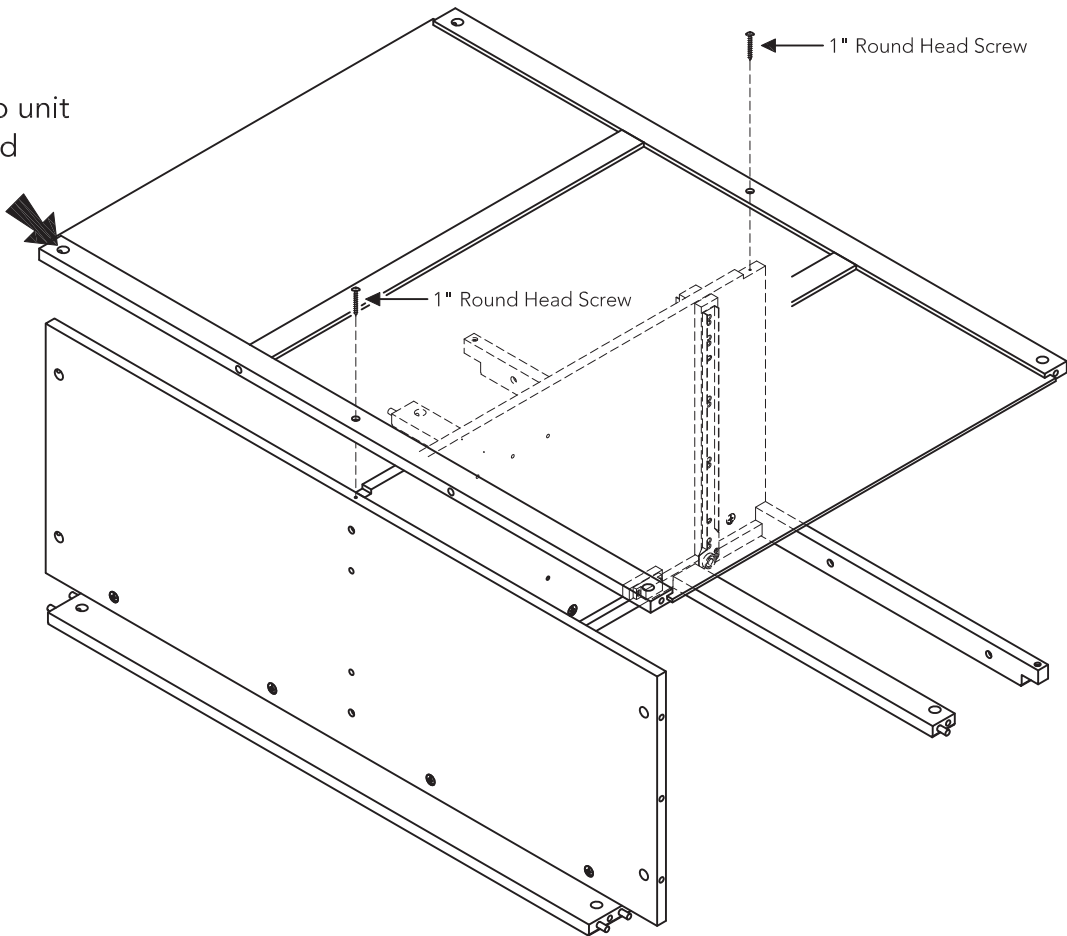

STEP 8

Attach Side Panels (B) and (C) to unit with Cam Locks, 1 1/4" Round Head Screws and Wooden Dowels.

Assembly Instructions 6/13

STEP 9

Attach Top (A) to unit with Cam Locks, 1" Round Head Screws and Wooden Dowels.

Note: A Philips screwdriver 5" or less in length is recommended.

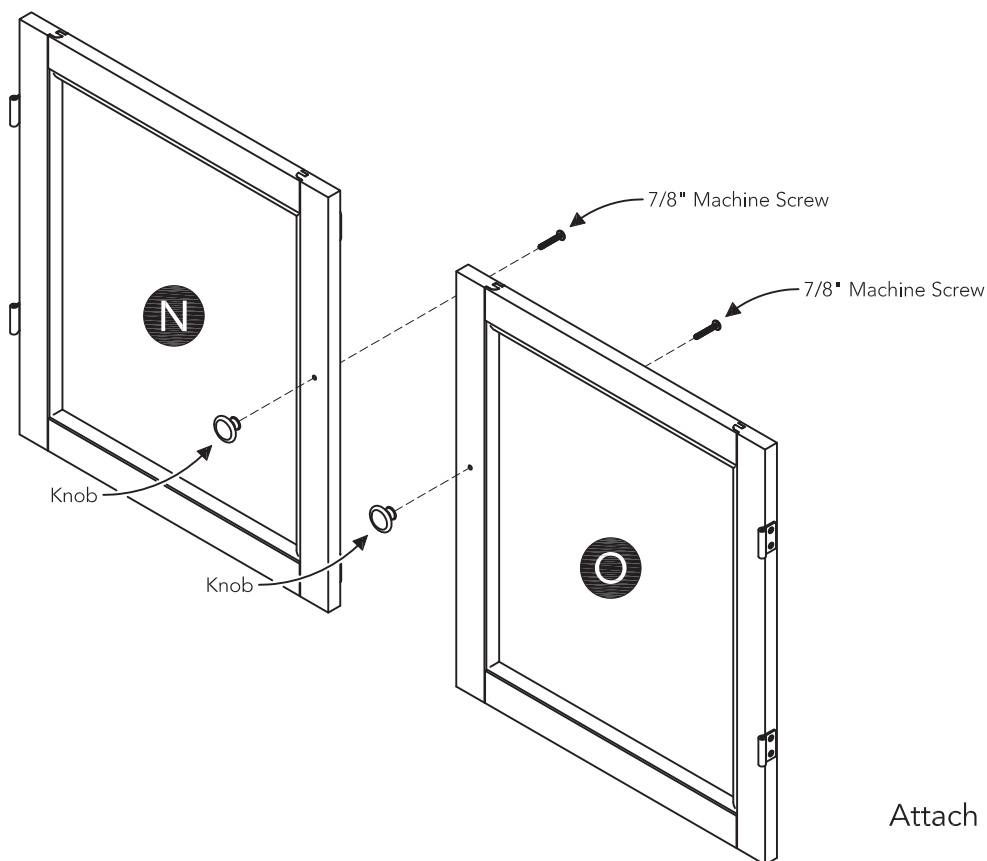
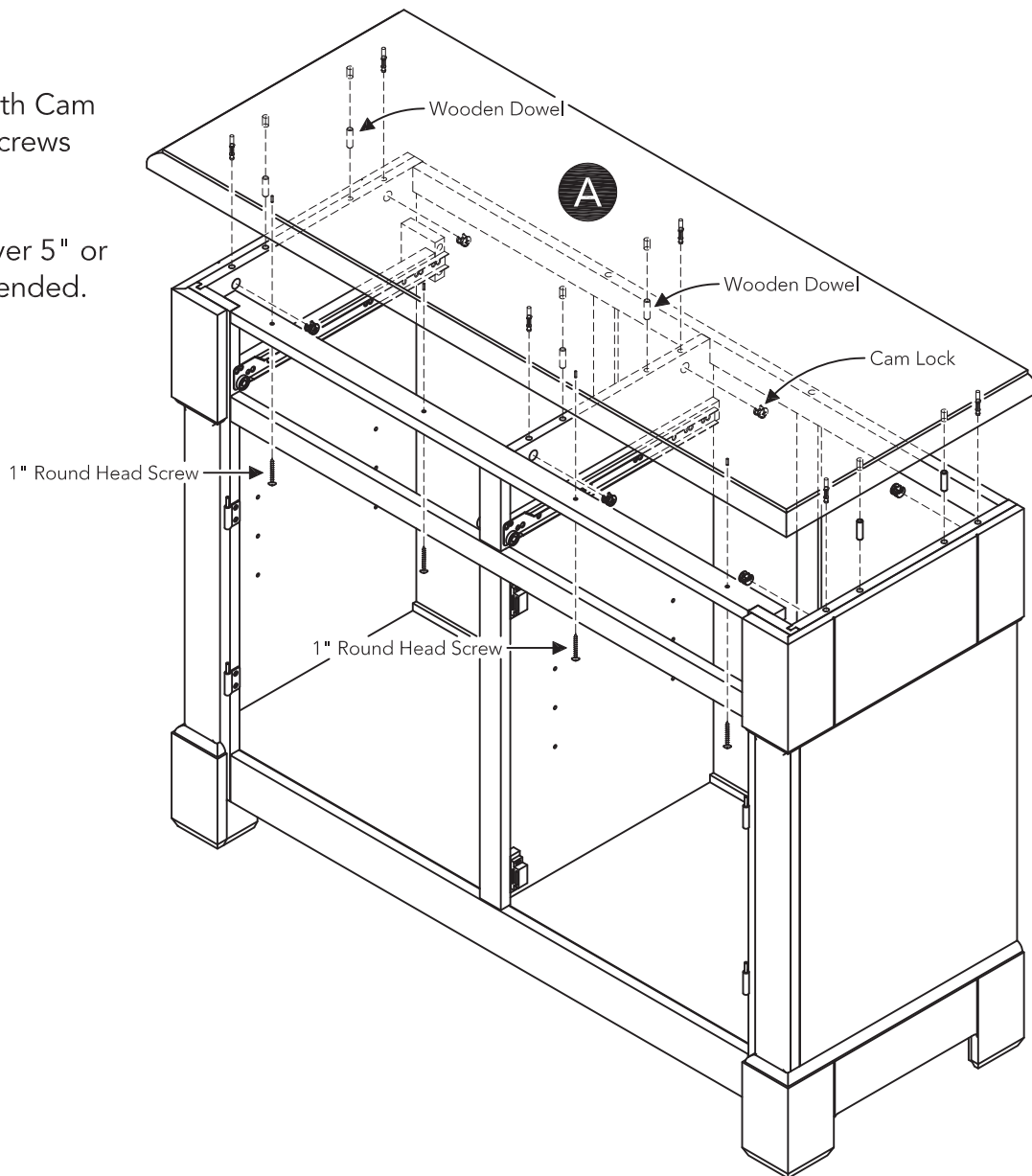

STEP 10

Attach Knobs to Doors (N) and (O) with 7/8" Machine Screws.

Assembly Instructions 7/13

STEP 11

Attach Doors (N) and (O) to unit by sliding door hinges into side panel hinges.
(See Figure 4)

Level unit by adjusting the adjustable levelers on bottom of unit.
(See Figure 5)

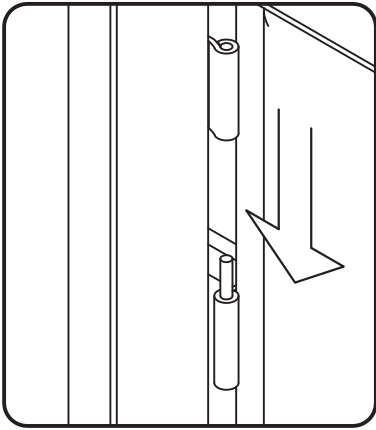

Figure 4

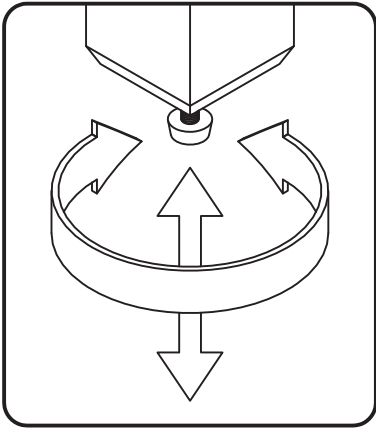

Figure 5

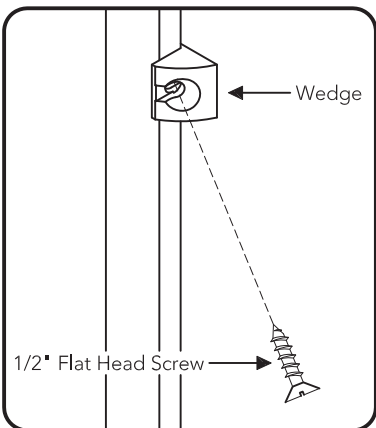
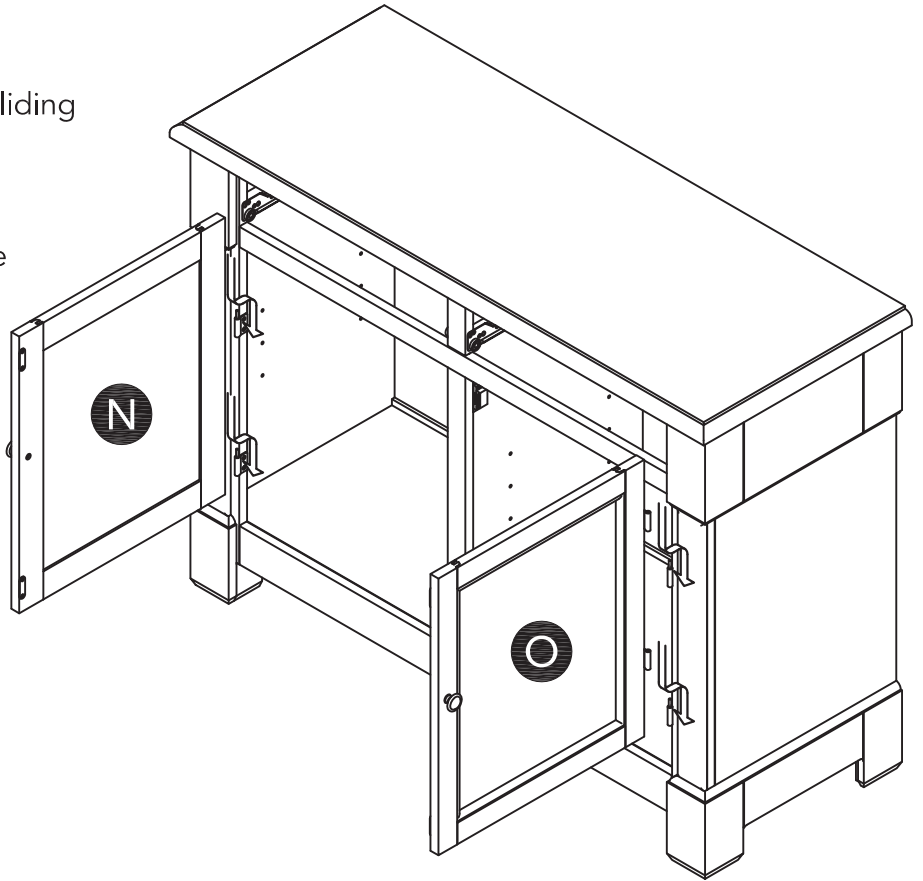

Figure 6



STEP 12

Attach Wedges to unit with 1/2" Flat Head Screws. (See Figure 6)

Note: Unit must be level before tightening these screws.

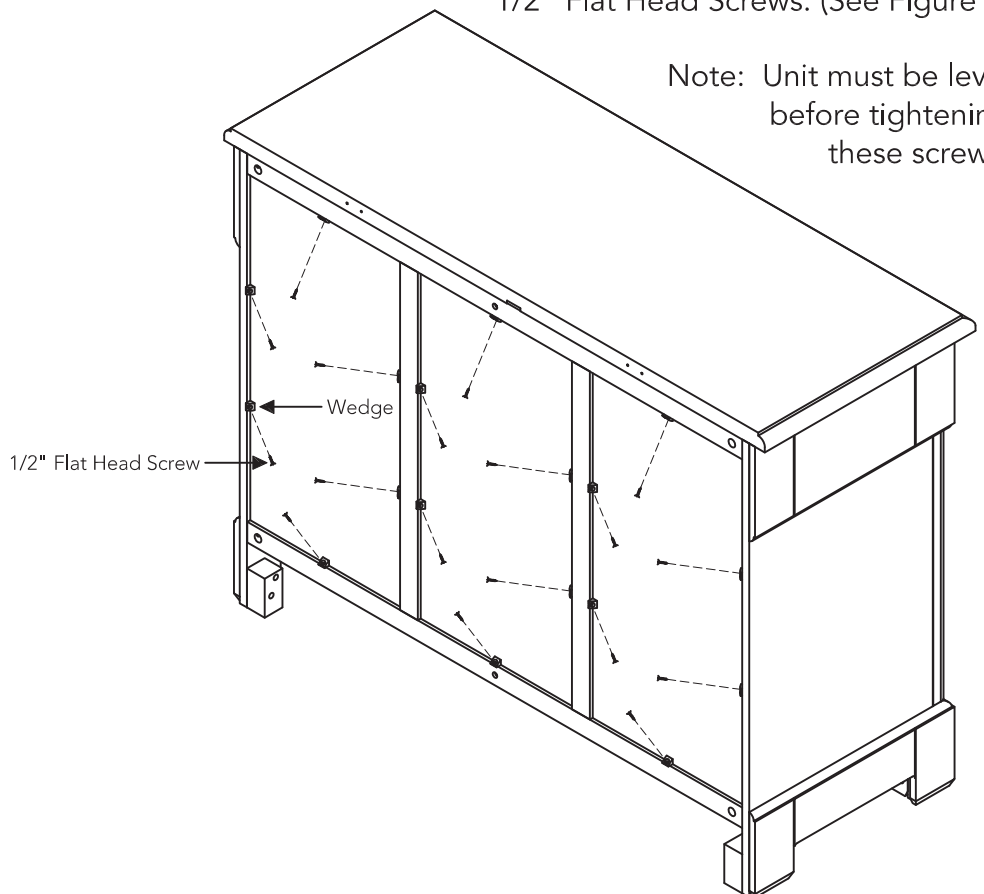

Assembly Instructions 8/13

STEP 13

Insert Adjustable Pins into side and middle panels at desired level.

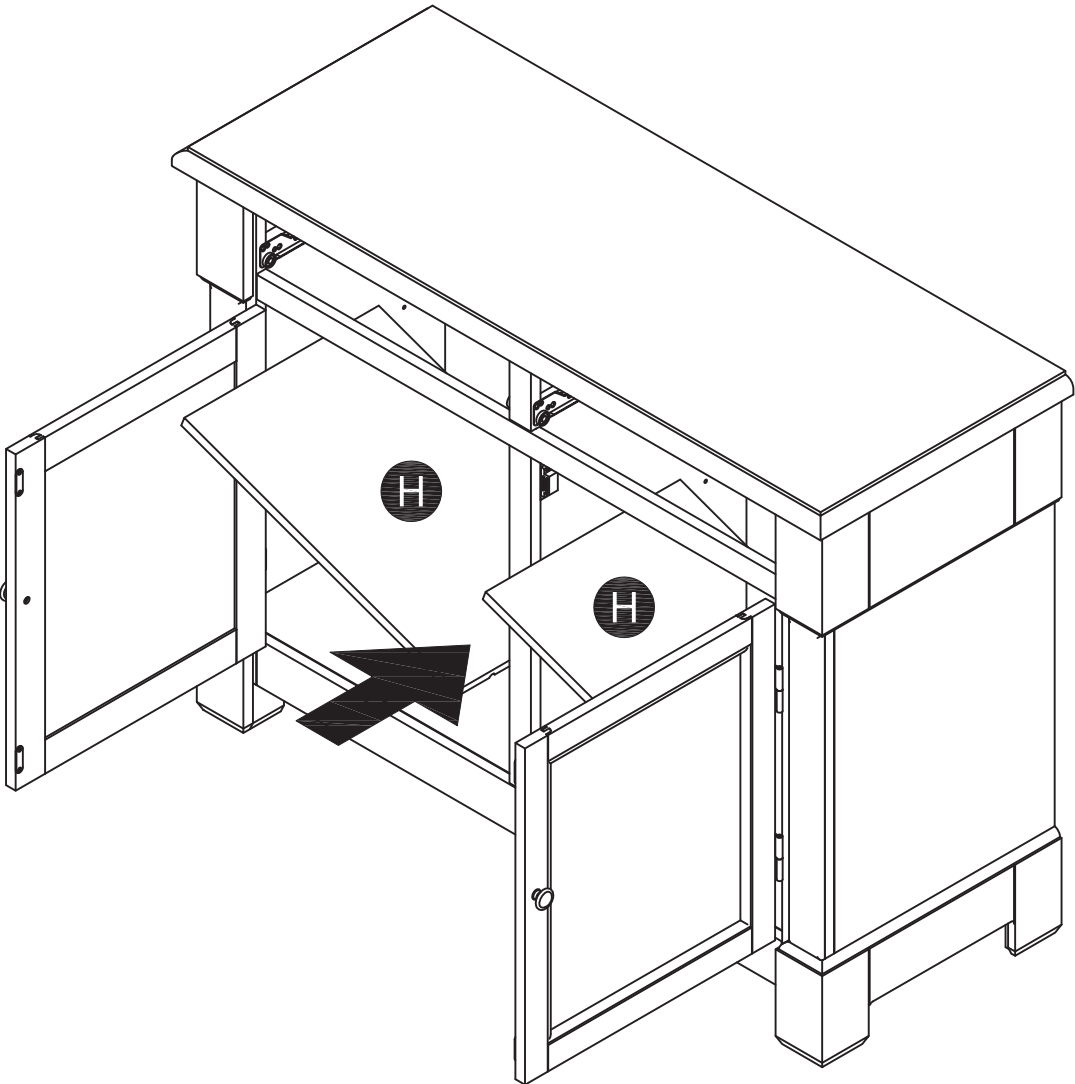
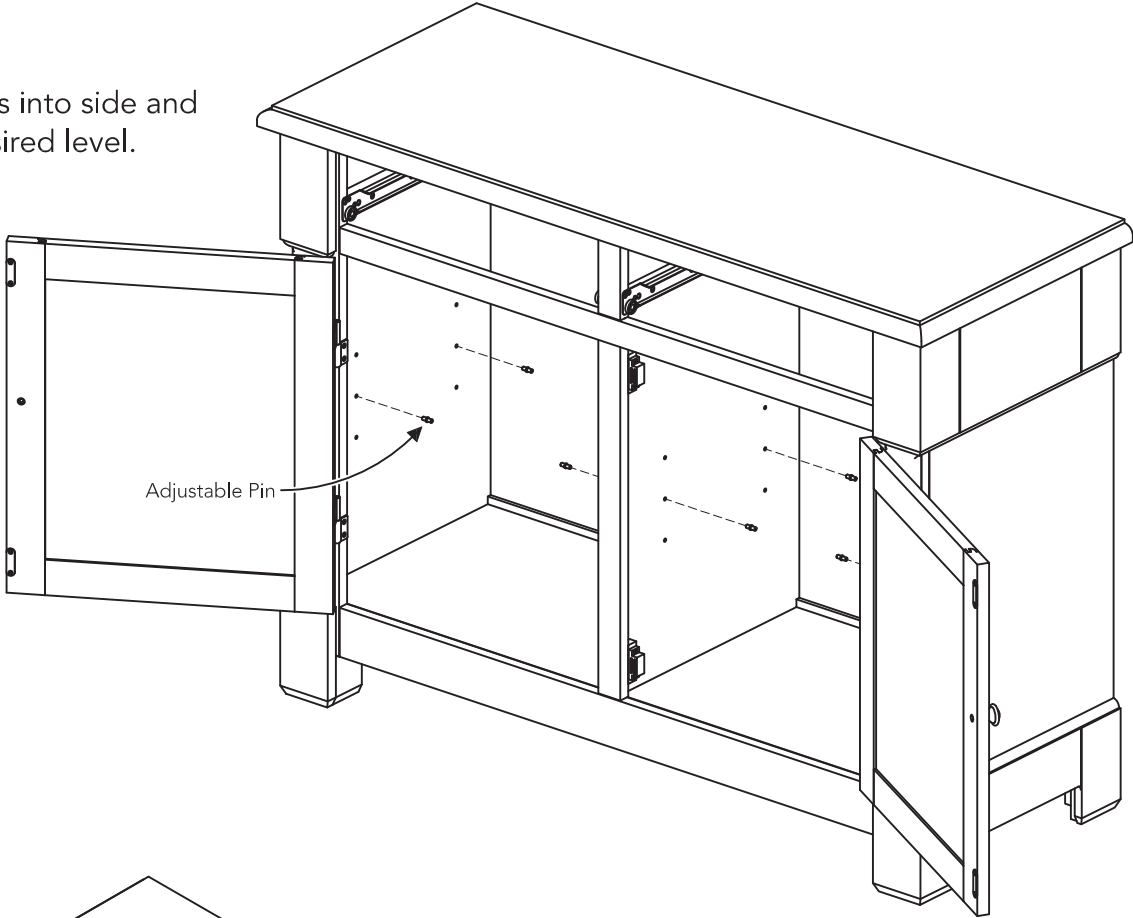

STEP 14

Place Shelves (H) into position.

Assembly Instructions 9/13

IMPORTANT

- To help reduce the risk of the unit tipping over, the Tip-over Restraint must be installed following these instructions exactly.

STEP 15

Place unit at desired location.

Mark wall with pencil just above and in-line with hole in Top (A). (See Figure 7)

Move unit.

Drill a 3/8" hole in wall 1 1/2" below mark.

Insert Anchor into the wall hole and attach Tip-over Restraint to Anchor with 1 1/2" Round Head Screw and Flat Washer. (See Figure 8)

Move unit back into place and insert Tip-over Restraint into unit through hole in Top (A). (See Figure 9)

Attach Tip-over Restraint to unit with 1/2" Round Head Screw and Flat Washer. (See Figure 10)

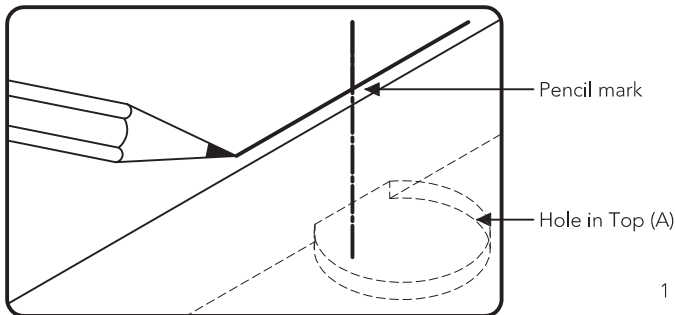
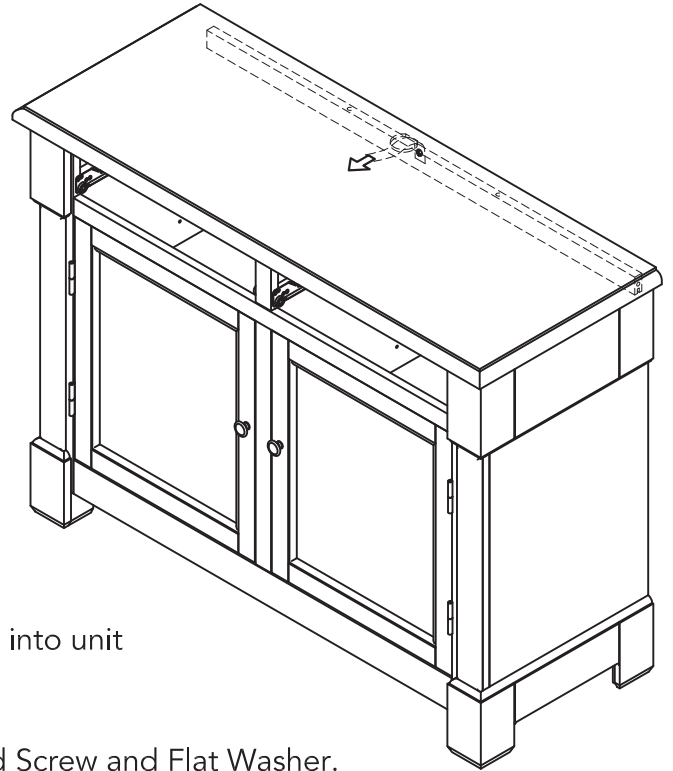

Figure 7

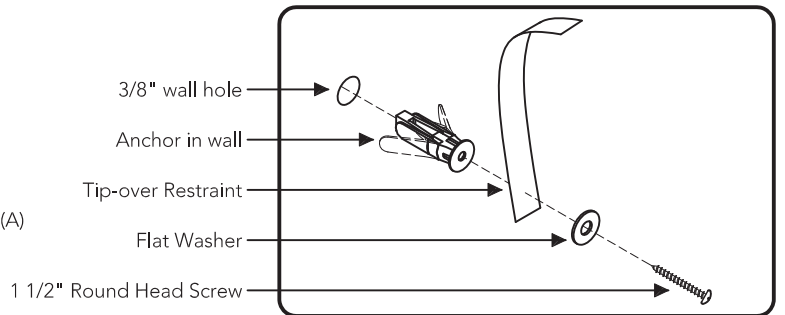

Figure 8

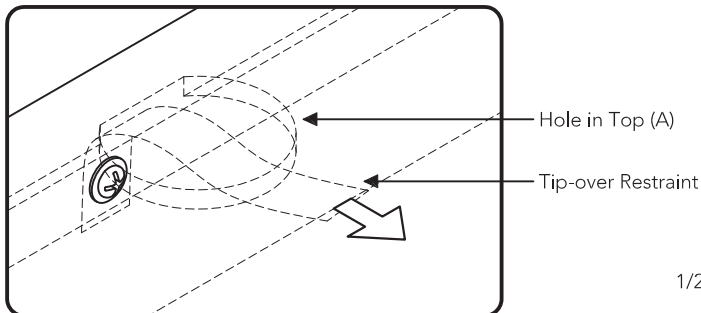

Figure 9

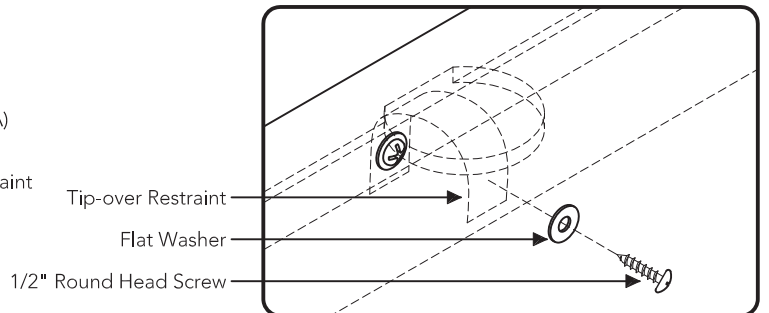
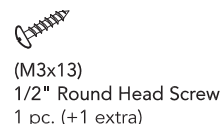
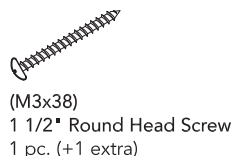
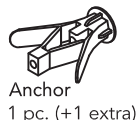
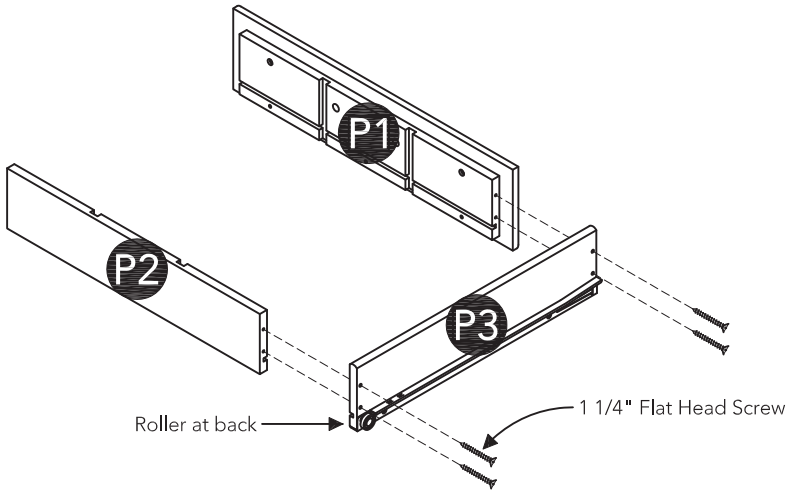

Figure 10

Hardware List



Drawer (P)



STEP 16

Attach Drawer Side (P3) to Drawer Front (P1) and Drawer Back (P2) with 1 1/4" Flat Head Screws.

STEP 17

Insert Drawer Bottom (P5) into groove.

Attach Drawer Side (P4) to unit with 1 1/4" Flat Head Screws.

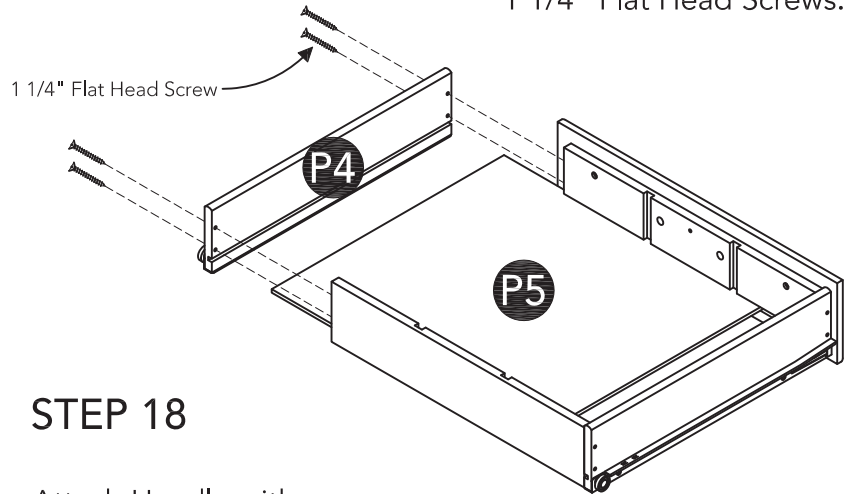

STEP 18

Attach Handle with 3/4" Machine Screws.

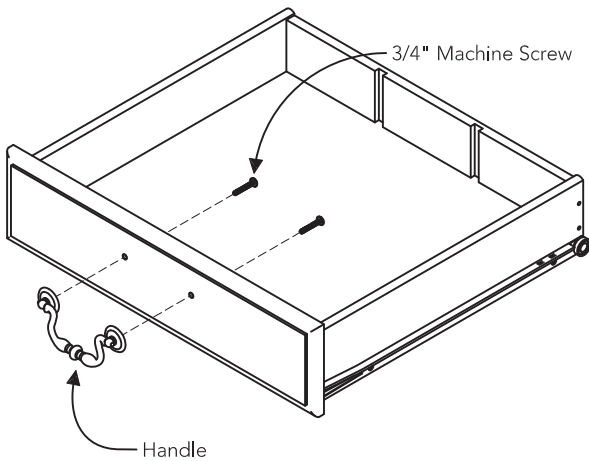

STEP 19

Slide Middle Panels (P6) into grooves.

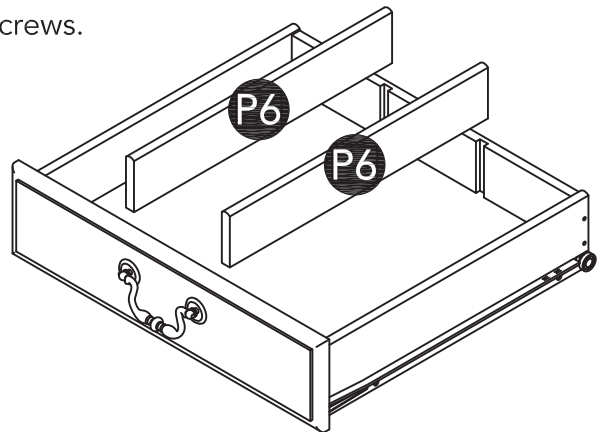

Note: Drawer assembly is not complete until 3/4" Flat Head Screws are used in a later step.

Part List

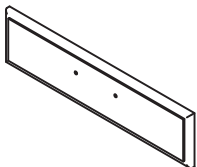

P1.
Drawer Front
2 pcs.

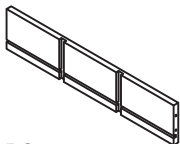

P2.
Drawer Back
2 pcs.

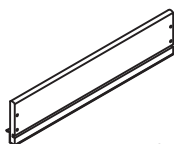

P3.
Drawer Side
2 pcs.



P4.
Drawer Side
2 pcs.

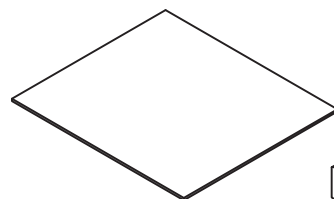

P5.
Drawer Bottom
2 pcs.

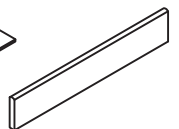

P6.
Middle Panel
4 pcs.

Assembly Instructions 11/13

STEP 20

Loosen slightly two screws pre-installed on back of drawer fronts.

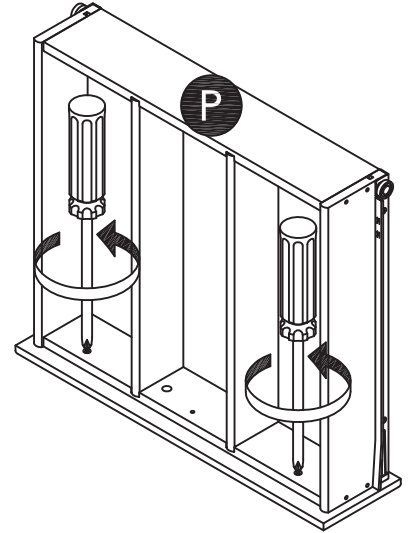

STEP 21

Insert drawers into unit, then adjust drawer front panels left or right and up or down until drawer gaps look proportional.

STEP 22

Pull drawers open slowly and re-tighten screws from Step 20.

Make sure front panels do not move and lock drawer front panels into position with 3/4" Flat Head Screws.

Note: These 3/4" Flat Head Screws must be installed to complete the drawer assembly.

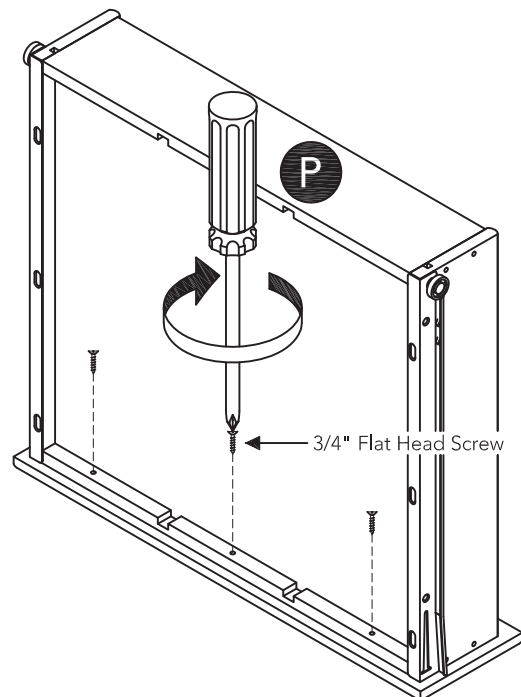
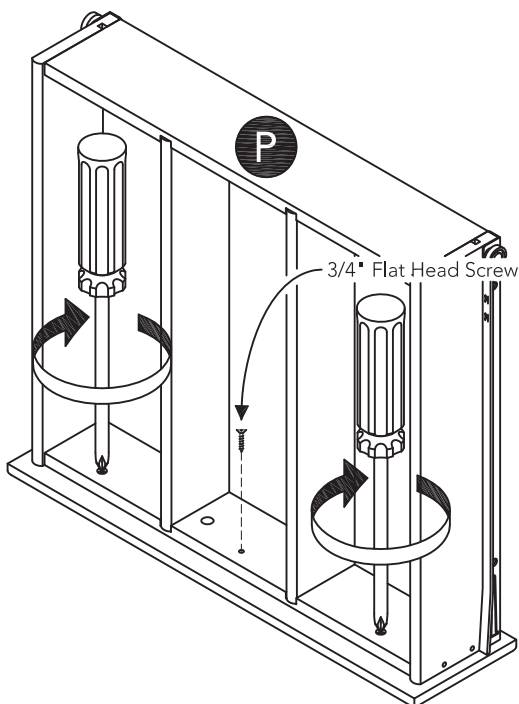

STEP 23

Slide Drawers (P) into position.

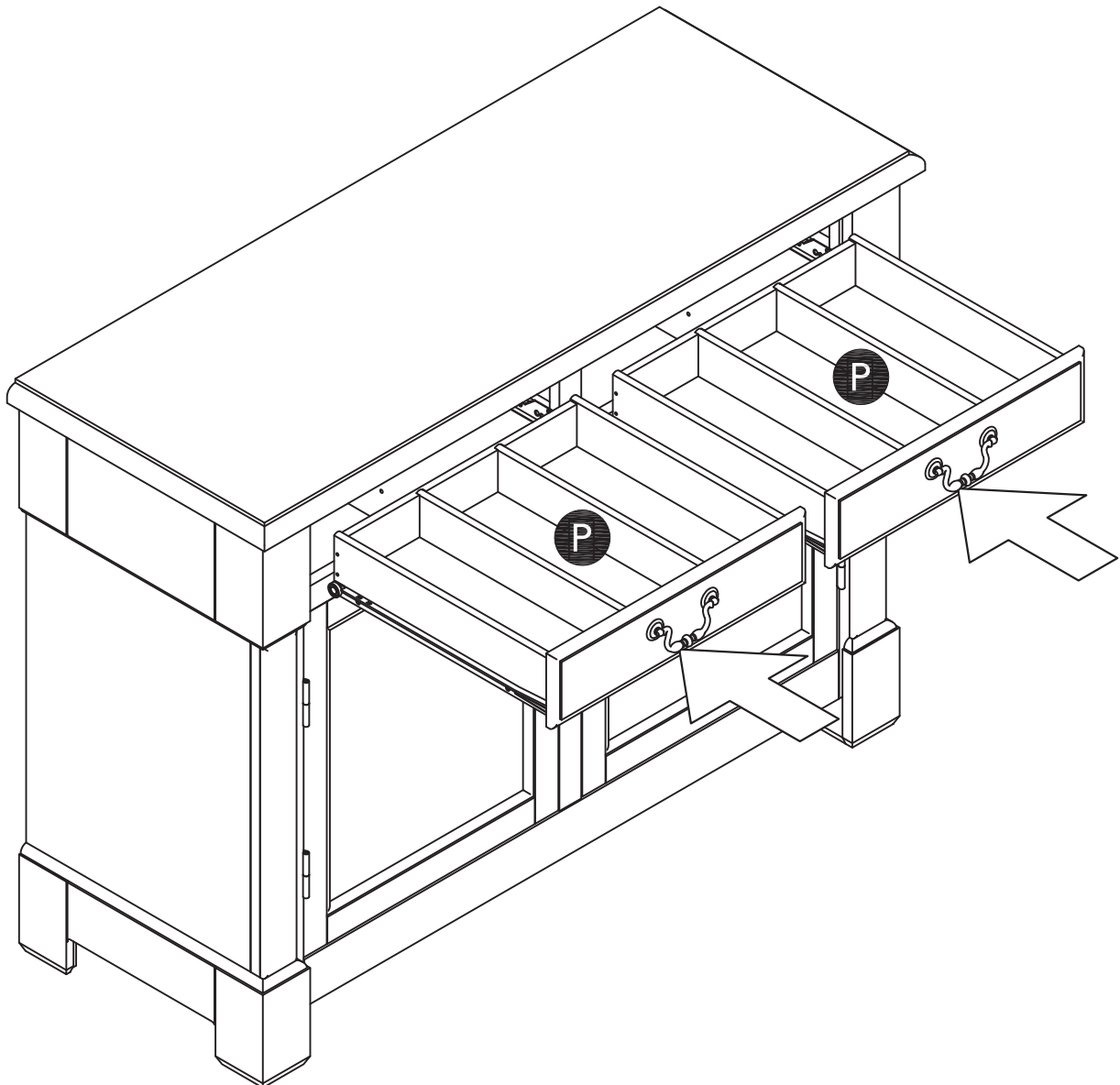

Assembly Instructions 13/13

IMPORTANT

- If magnetic door catches are too strong and door difficult to open, magnetic power can be reduced and door made easier to open by doing following:

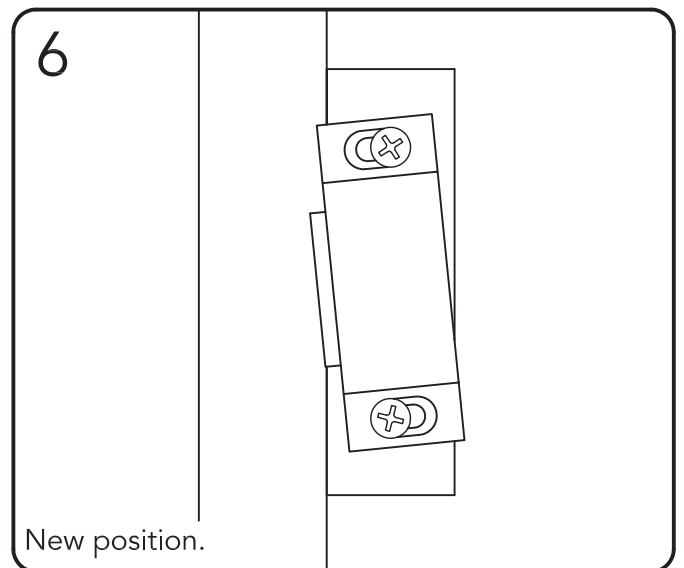
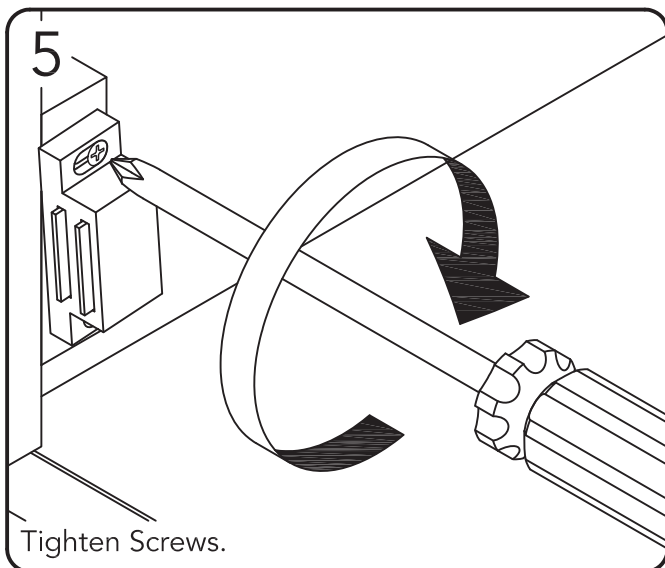
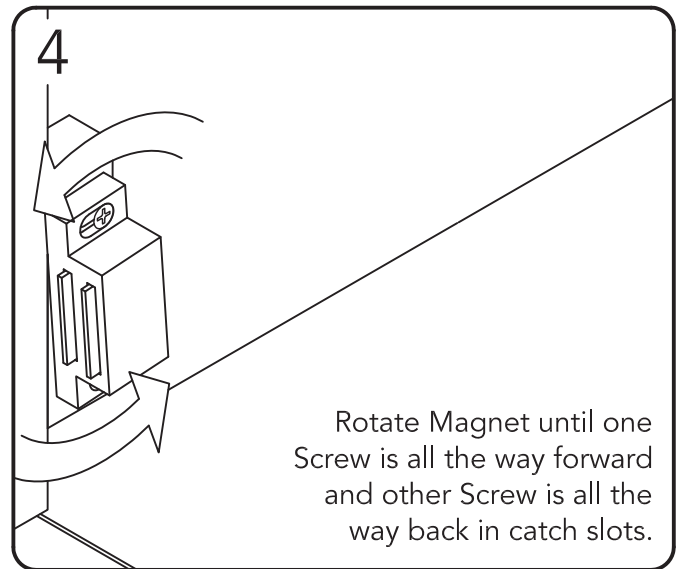
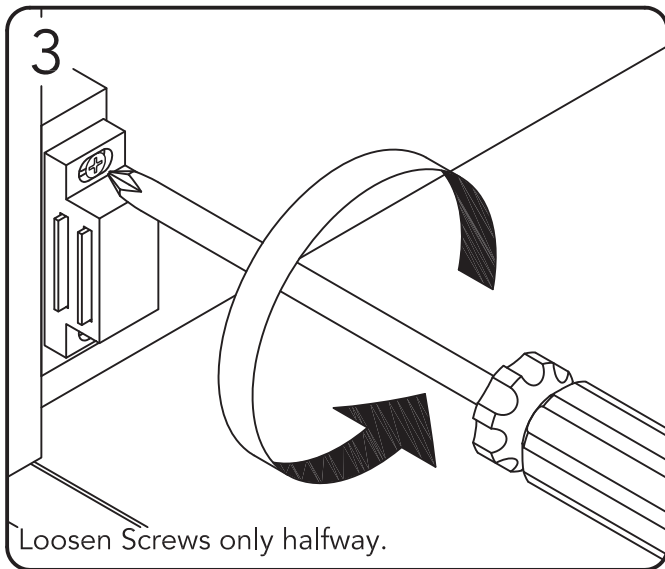
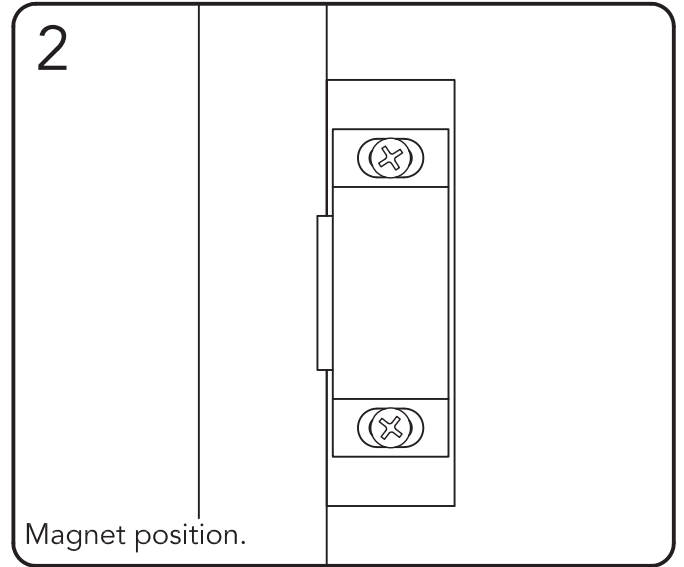
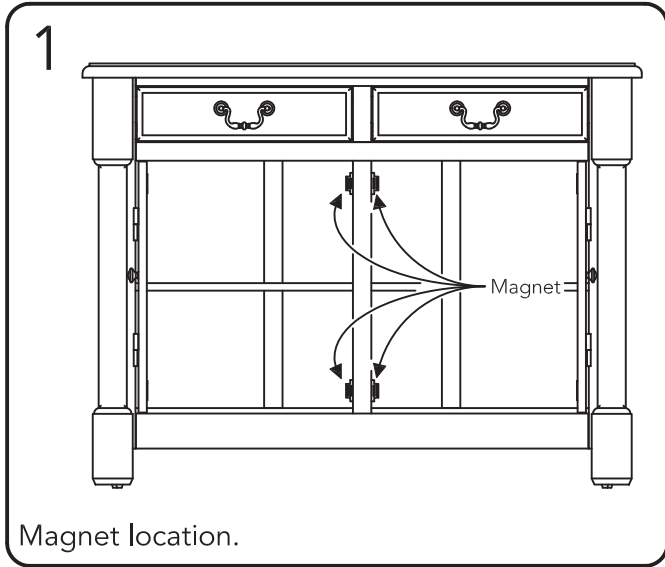

CARE INSTRUCTIONS

NEVER

allow liquids to remain on furniture.
Absorption causes parts to warp
and split and finishes to delaminate.

NEVER

use glass cleaners on
finished furniture. Ammonia
chemically attacks the finish.



Do not use power tools
above 8 volts to assemble.

**PREVENT
CRACKING**



Do not place
in direct sunlight.

**PREVENT
FADING**



Do not write
directly on surface.

**PREVENT
MARKING**



Do not place hot
objects on surface.

**PREVENT
FINISH DAMAGE**



Do not use rubber
based placemats.

**PREVENT
DISCOLORING**



Do not use commercial
waxes and polishes.

**PREVENT
YELLOWING**

CLEAN

with a soft cloth moistened
in lukewarm soap and water.
Buff with a dry clean cloth.



We will provide replacements free of charge for missing or damaged hardware or parts within 30 days of purchase. Digital images of the defective parts may be required. If the product was not purchased from an authorized retail affiliate, we are under no obligation to provide replacement parts. Parts are not available for fully assembled items nor are parts available for sale. Replacements for missing or damaged hardware or parts may be requested