

CARE AND MAINTENANCE

Unplug lamps before using any cleaning solutions. Dust shades with a feather duster or with an appropriate vacuum-brush attachment. Wipe with a soft, dry cloth and clean lamp bases with the methods appropriate to the material. Avoid the use of chemicals and household cleaners as they may damage the finish.

NOTICE & IMPORTANT SAFETY INSTRUCTIONS

- * Please make sure that you have all parts indicated before you begin assembly of this item
- * This item should be assembled on a soft surface to prevent scratching the finish during assembly
- * To reduce the risk of fire, electrical shock or injury to persons or property, please follow the guideline below for safe use and installation
- *The external metal body or solar panel of this lamp cannot be replaced;
If the solar panel is damaged, the lamp shall be destroyed

SOLAR PANEL INSTRUCTION MANUAL

*When using for the first time, pressing the button of power, solar light source will operate. In the daytime when there is more light, the light source will not light up, when it comes to the night time or there is not enough light, the solar light source will automatically light up. It is not necessary to press the POWER button after that.

2V/80ma solar panel :

*Battery: 1xAA 1.2V/600mah Ni-mh



*Charging time: 5-6H.

*Working time: 6-8H.

*Charging effect is affected by weather and light conditions. Charging effect is best in full sunlight.

*During the winter months or raining weather, the solar light does not receive enough energy from the sunlight, so brightness and shorter working time are normal.

Part List and Hardware List

PIECE	DESCRIPTION	PICTURE	QUANTITY
A	Lamp body		3X
B	Solar panel		3X

JY
JONATHAN Y

Model#: JYL2604-3SET

Product Dimensions: S: 7.5"Lx7.5"Wx10.13"H

M: 7.5"Lx7.5"Wx14"H

L: 7.5"Lx7.5"Wx19.5"H

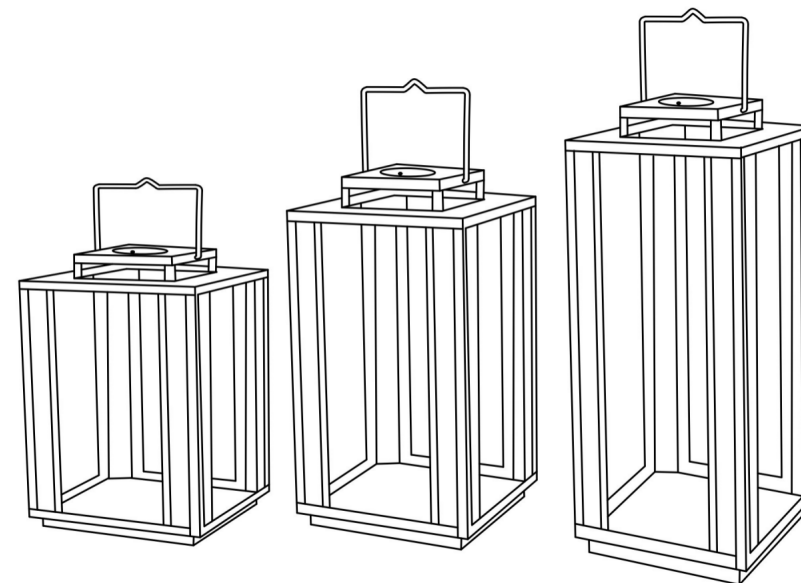

PREPARATION

Before beginning assembly of product, make sure all parts are present. Compare parts with package contents list and hardware contents list. If any part is missing or damaged, do not attempt to assemble the product.

Estimated Assembly Time: 1 minutes.

If there are any questions relating to defects, missing parts, assembly issues, replacements, or device connectivity issues, please send a detailed email to cs@jonathany.com

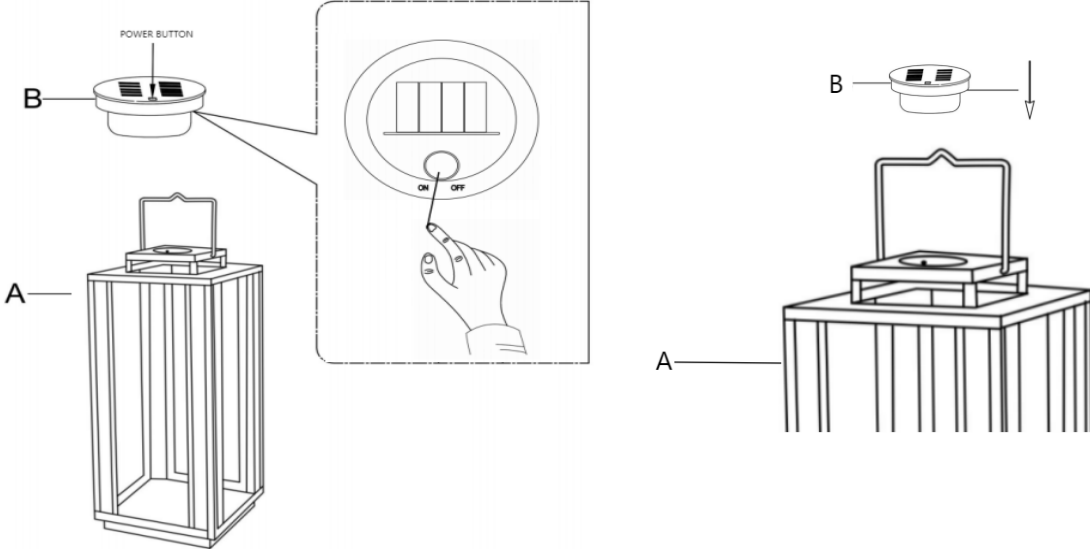
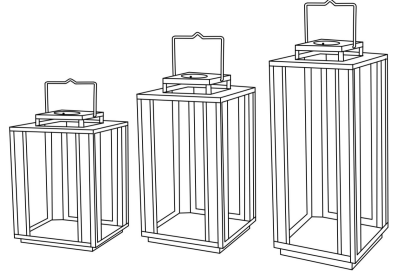
	
<p>Touch Switch</p> <ol style="list-style-type: none">1. When using for the first time, pressing the button of power, solar light source will operate. It is not necessary to press the POWER button after that.3. Assemble back to the Solar panel(B) as shown.	<p>Put the light on a level surface to check if everything is stable</p>

ENJOY YOUR LAMP