

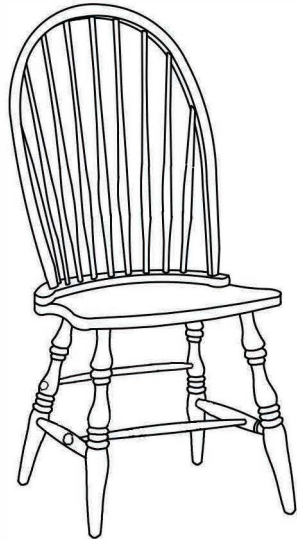









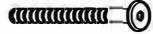



# ASSEMBLY INSTRUCTION

NOTE: TOOLS REQUIRED-NOT SUPPLIED

## WINDSOR CHAIR



PART LIST			HARDWARE LIST		
NO	DESCRIPTION	QTY	NO	DESCRIPTION	QTY
1	Chair Back Assembly 	1 PC	A	Jcbsc Screw M6 X 60MM 	4 PCS
2	Chair Seat 	1 PC	B	Jcbsc Screw M6 X 35MM 	10 PCS
3	Chair Leg (L) 	1 PC	C	Spring Washer M6 	14 PCS
4	Chair Leg (R) 	1 PC	D	Barrel Nut 	4 PCS
5	Center Stretcher (Long) 	1 PC	E	Wood Button 	4 PCS
6	Back Stretcher (Short) 	1 PC	F	Allen key M4 	1 PC
			G	Adjustable Leveller 	4 PCS

### Step 1

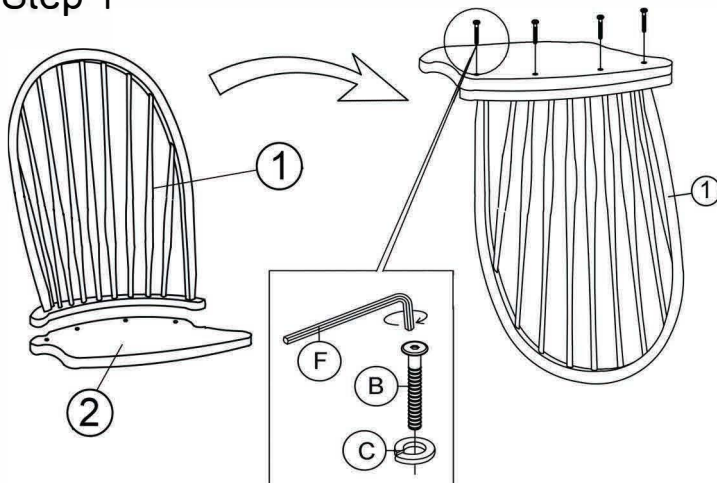

### Step 2

Assemble front & back stretcher (5 & 6) to the Chair Legs (3 & 4), fix it by using Barrel Nut (D) and JCBC Screw (A) as shown.  
**\*Do not fully tighten the screw until final step.\***

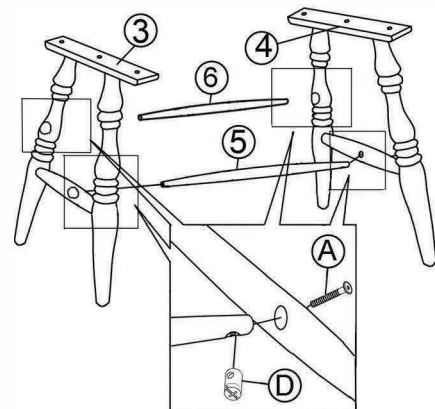

### Step 3

Assemble chair leg frame to chair seat (2) with JCBC screw (B)  
 Affix one Adjustable Levellers (G) to the bottom of each chair leg.

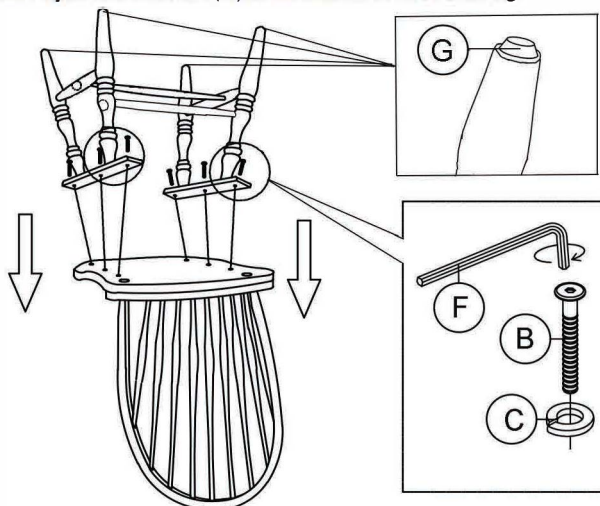

### Step 4

Fully tighten all the screws, cover JCBC screw holes with Wood Buttons (E).

