







Assembly Instructions

Caution : You must read this before you proceed

Care & Maintenance



- ⊘  ● Not for commercial use. For residential use only.
 - ✓  ● Furniture may scratch floors. We recommend using furniture pads to protect your floors.
 - ⊘  ● Do not put hot items directly on furniture surface.
 - ⊘  ● Do not clean furniture with harsh cleansers or polish.
 - ⊘  ● Do not place furniture under direct sunlight.
 - ⊘  ● Do not place furniture near heating or cooling vents.
 - ⊘  ● Do not write on furniture without a padded barrier to protect the surface.
 - ⊘  ● Do not place furniture outside . For indoor use only.
 - ⊘  ● Stains may be removed with mild soap solution and damp cloth.
 - ⊘  ● Children should not climb or jump on the furniture.
- ✓  ● Dust and pick-up spills using a clean, non-colored, lint-free cloth.

Please look in carton for hardware packs and legs.
Sets often ship in multiple boxes and may arrive a day or two apart.

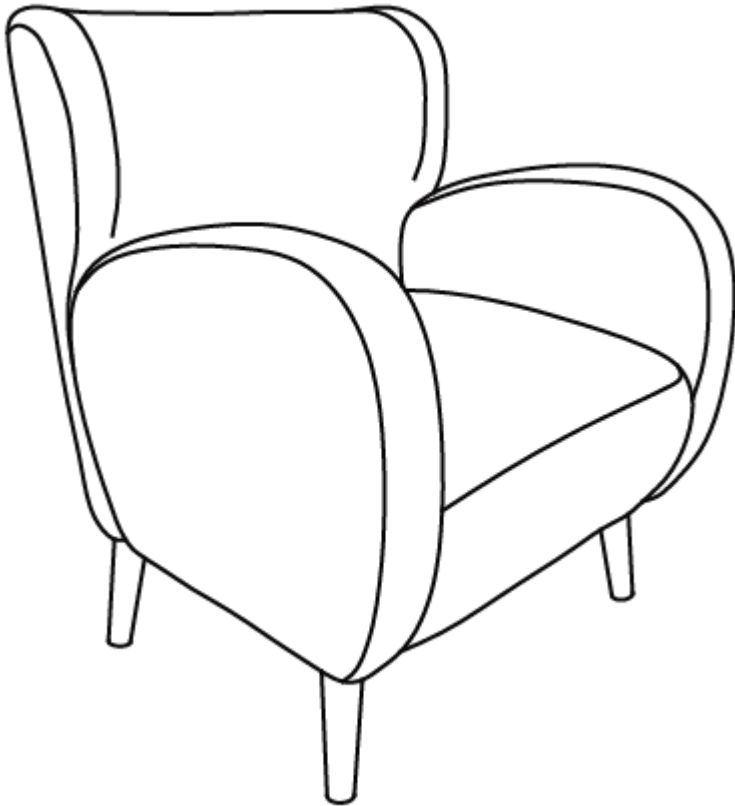

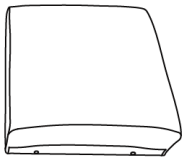
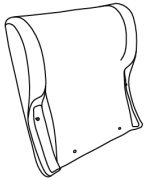

Club Chair

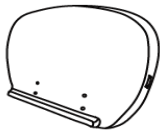
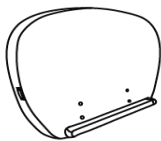

Parts List

Label	Picture	Description	QTY
A		Chair Seat	1
B		Backrest	1
C		Leg	4
D		Left Armrest	1
E		Right Armrest	1

Hardware

Label	Picture	Description	QTY
①		Bolt(M8*70 MM)	11
②		Washer	11
③		Gasket	5
④		Allen Wrench	1
⑤		Spring Washer	11

Assembly Preparation

Before Beginning Assembly:

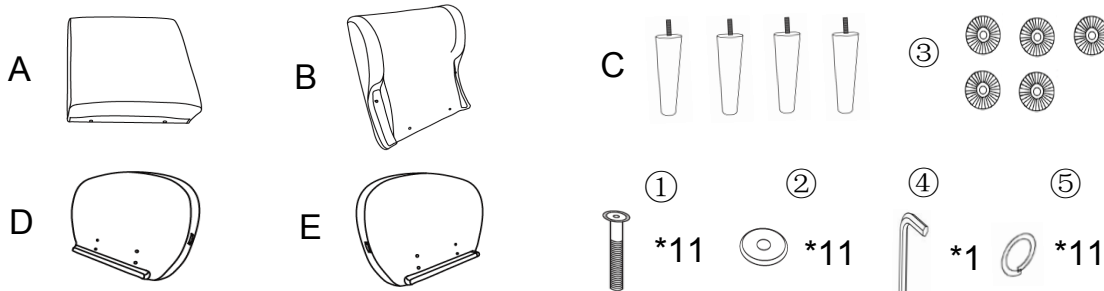

- Read instructions, cover to cover-



- Have 2 adults on hand for assembly-



- Do not assemble on flooring or carpet-



- Assemble on a clean non-marring surface (packing foam)-



- Save all packaging until finished-

Assembly Steps

Overview

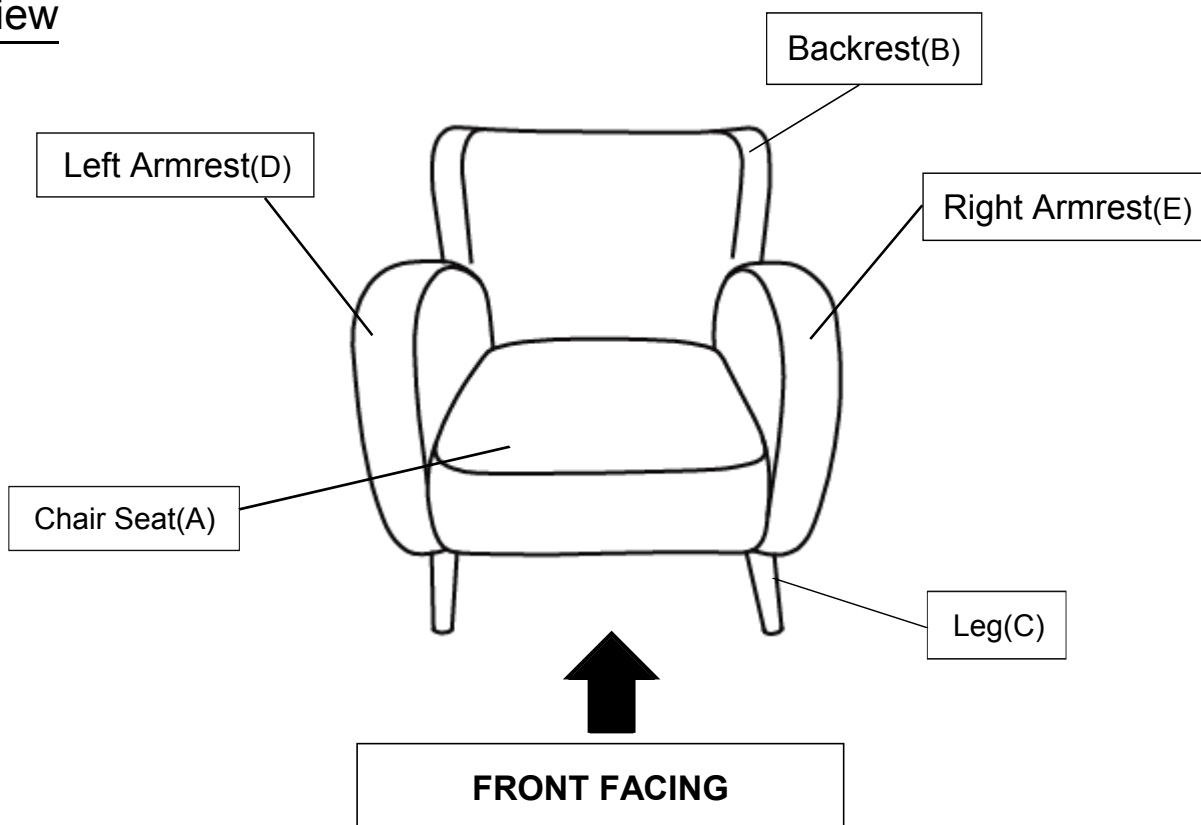

This Chair has multiple parts and may require up to 30 minutes to assemble.

To give you an overview of the Chair, the above picture is to help you put the various parts into perspective.

Please read through the instructions below to familiarise yourself with the parts and steps before assembly.

Note: It is recommended that you have an adult partner to assist during the entire assembly process.

Step 1

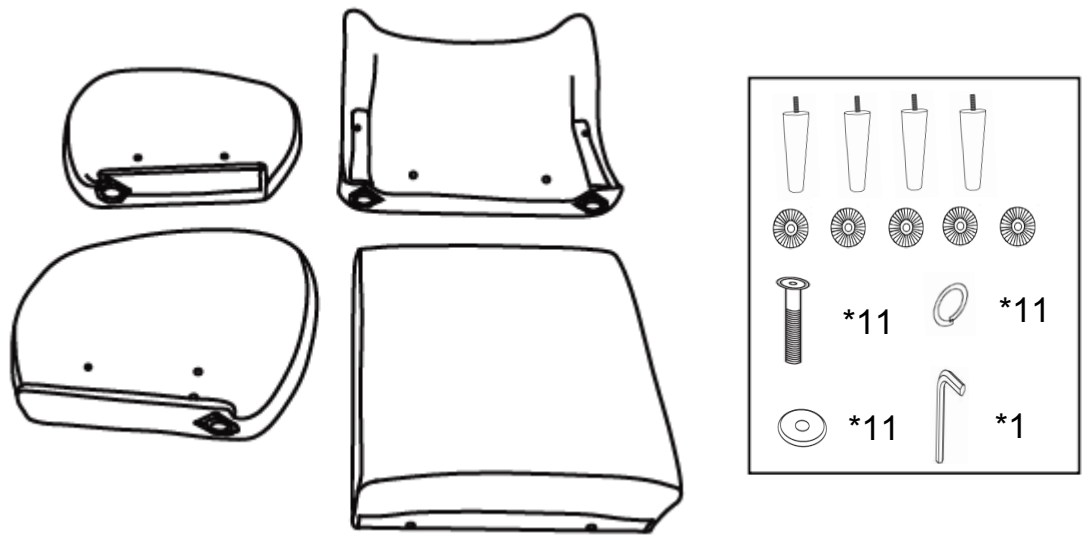

Position the Chair Seat(A), Backrest(B), Leg(C), Left Armrest(D) and Right Armrest(E) on a clean, non-marring surface as shown.
Carefully take out the Legs(C) and Hardware from the bottom of the Chair Seat(A).

Step 2

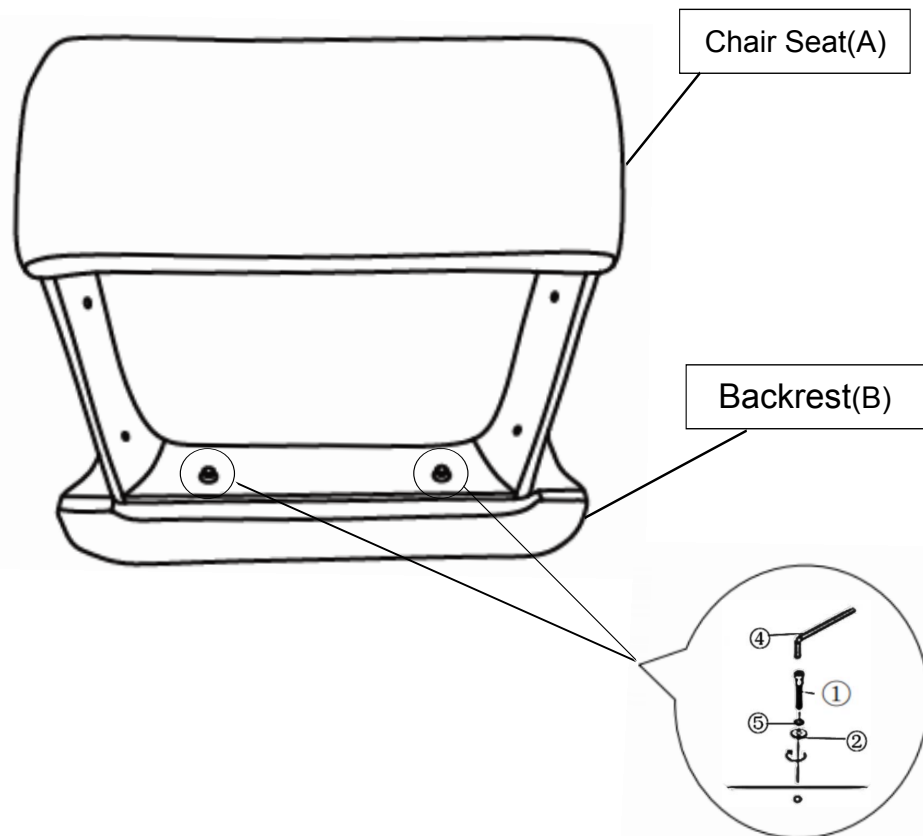

With assistance from an adult partner, lift the Chair Seat(A) up, place it on top of Backrest(B). Attach Chair Seat(A) to Backrest(B) using a Bolts(), Spring Washers(), and Washers() with the Allen Wrench () as pictured above.

Note: Do not fully tighten the bolts.

Step 3

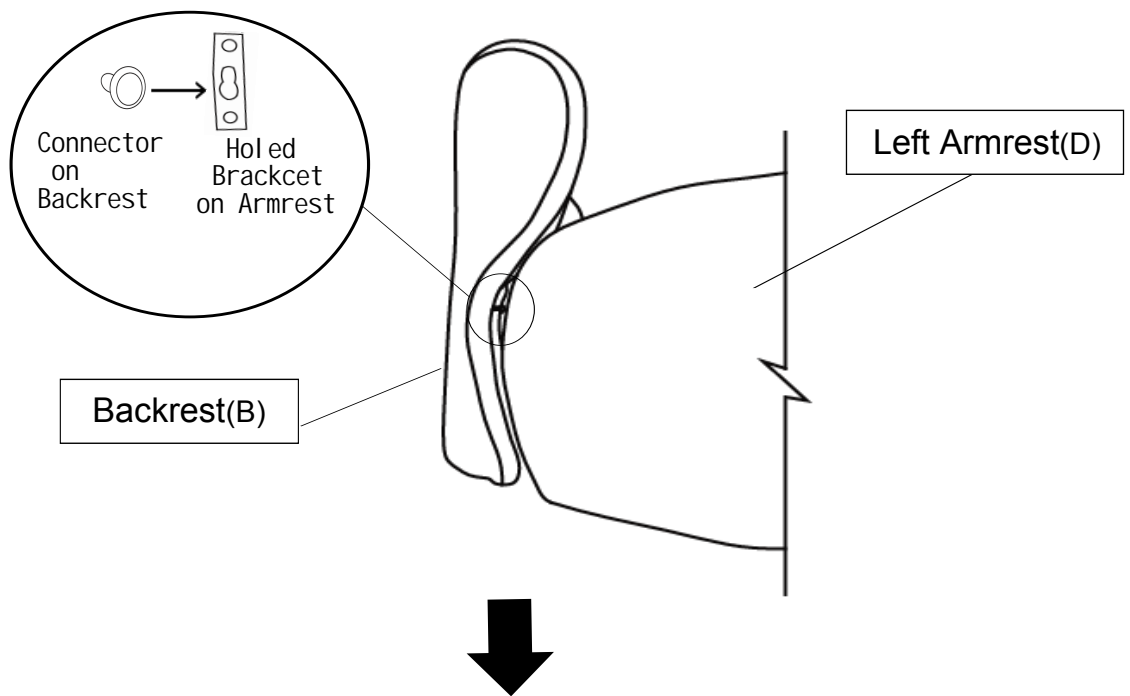

Turn the assembled Chair Seat(A) and Backrest(B) over.

With the assistance from your partner, lift the Left Armrest(D) up, align the Connector on the Backrest(B) with the Holed Bracket on the Left Armrest(D).

Insert the Connector head into the Hole (large side).

Note: Please push the Armrest towards the Backrest a little when inserting connector.

Step 4

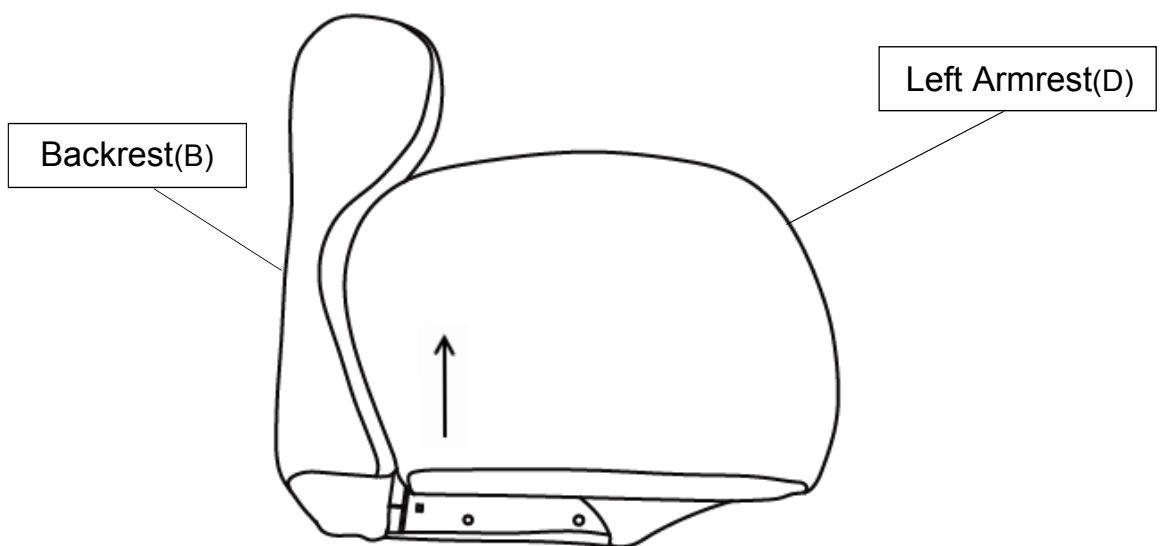

Push up the Left Armrest (D) until the Connector move into the Hole (small side) and touch the Hole's upside edge.

Note: Make sure Step 3 is correctly acted, then do this step.

Step 5

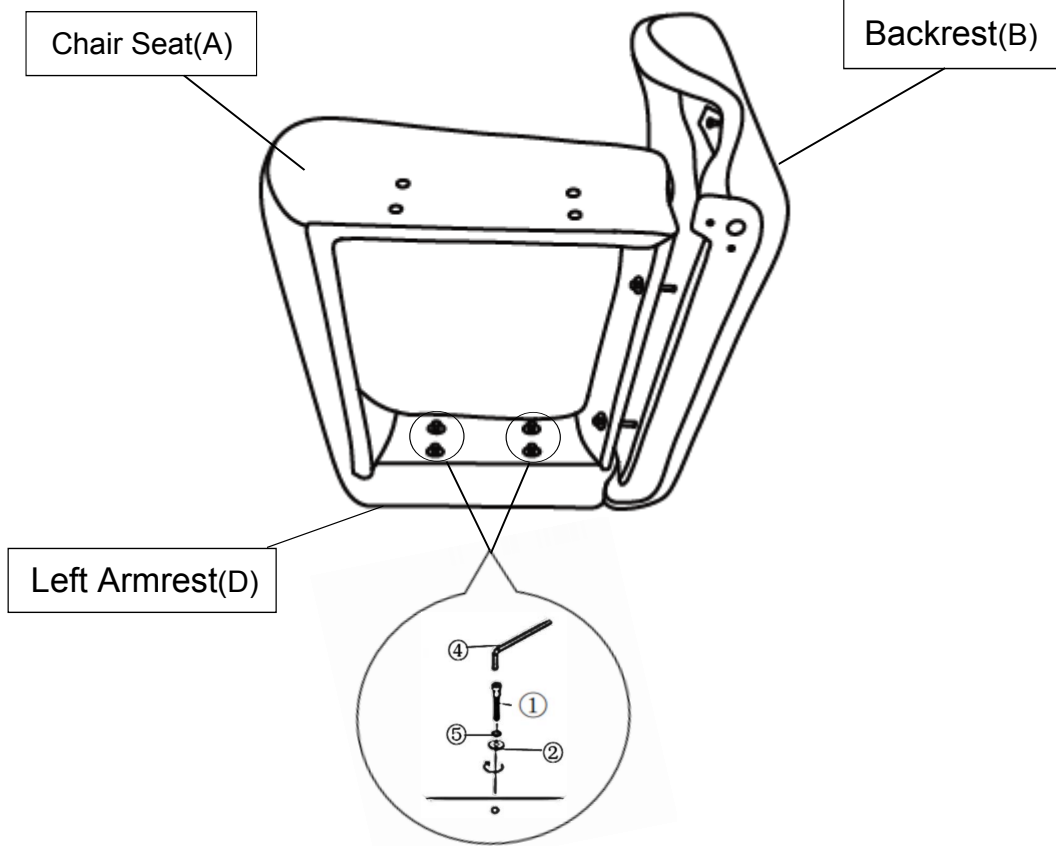

Turn the assembled Chair lying on Left Armrest (D) as picture shown.
Attach Left Armrest(D) to Chair Seat(A) using Bolts(), Spring Washers(), and Washers()
with the Allen Wrench () as pictured above.

Tighten the Bolts fully in a sequential manner.

DO NOT fully tighten a Bolt in one go and then move on to the next.

Rather, In a sequential manner, gradually tighten each Bolt until all Bolts are evenly secured.

Step 6

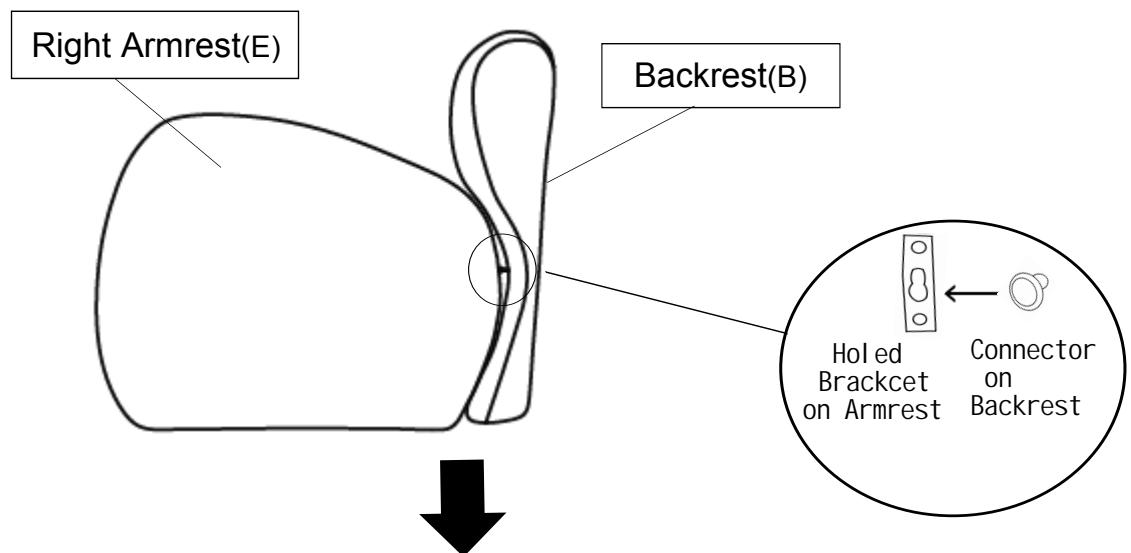

Turn over the assembled Chair.

With the assistance from your partner, lift the Right Armrest(E) up, align the Connector on the Backrest(B) with the Holed Bracket on the Right Armrest(E).

Insert the Connector head into the Hole (large side).

Note: Please push the Armrest towards the Backrest a little when inserting connector.

Step 7

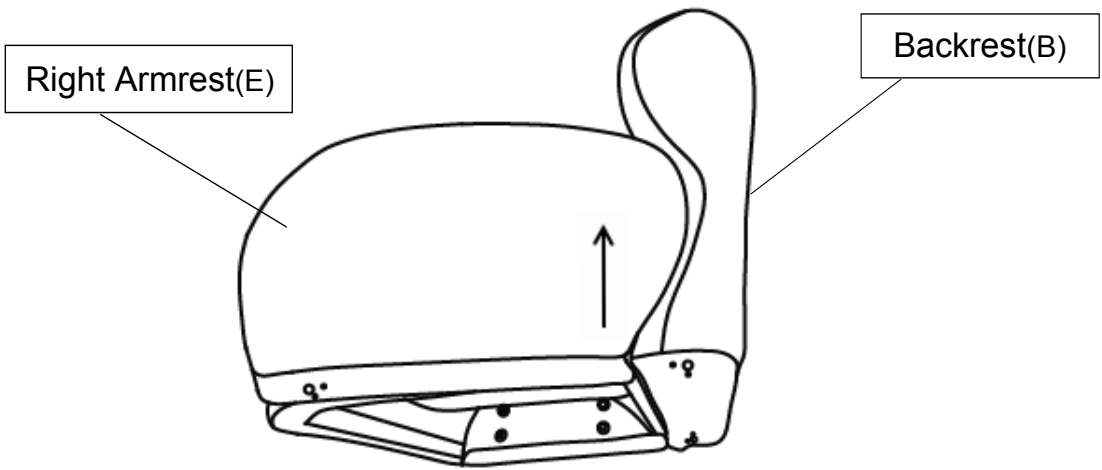

Push up the Right Armrest (E) until the Connector move into the Hole (small side) and touch the Hole's upside edge.

Note: Make sure Step 6 is correctly acted, then do this step.

Step 8

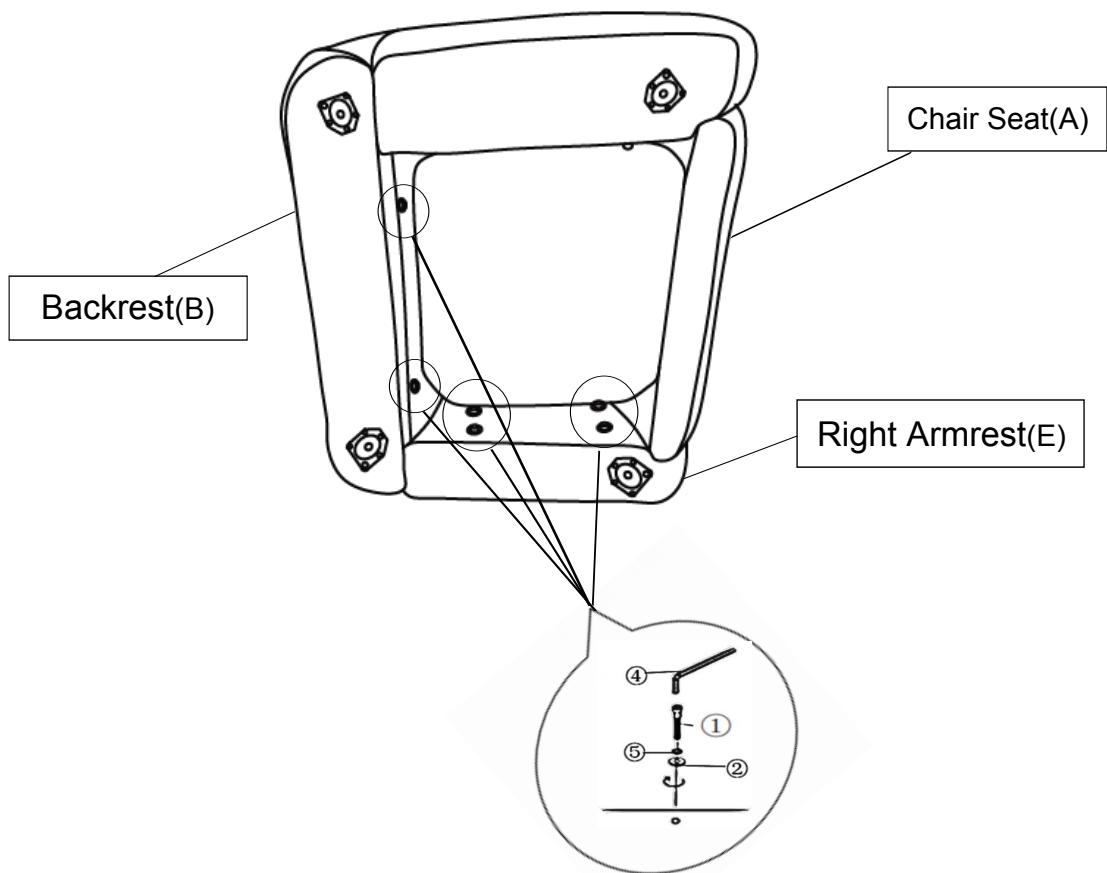

Turn the assembled Chair lying on Right Armrest (E) as picture shown.

Attach Right Armrest(E) to Chair Seat(A) using Bolts(), Spring Washers(), and Washers() with the Allen Wrench () as pictured above.

Tighten the Bolts fully in a sequential manner.

Tighten the Bolts on Chair Seat (A) to Backrest (B) side fully.

Step 9

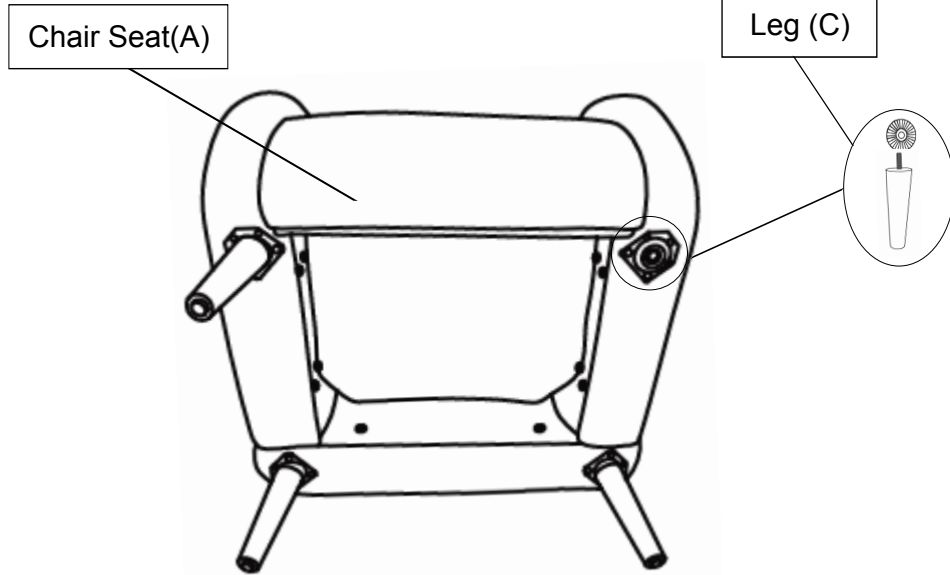

Install the Leg(C) onto the bottom of the Chair by placing one Gasket(③) on the threaded stem. Then insert the threaded stem into the threaded mounting position at the corner of the Chair. Tighten by turning the Leg clockwise.

Repeat the same step to install the remaining Legs.

Note: The use of Gaskets are OPTIONAL and are especially useful to help alleviate slight wobble. Some Legs may need more than one whilst some legs may not need any.

Step 10

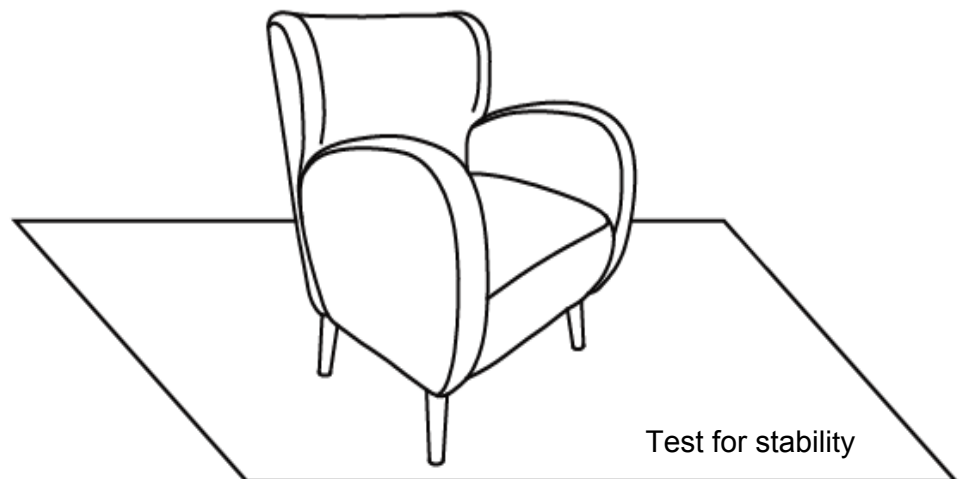

Your Chair is ready for use.

This Chair can only be used on a flat, level surface.