

# 5 - Drawer Chest

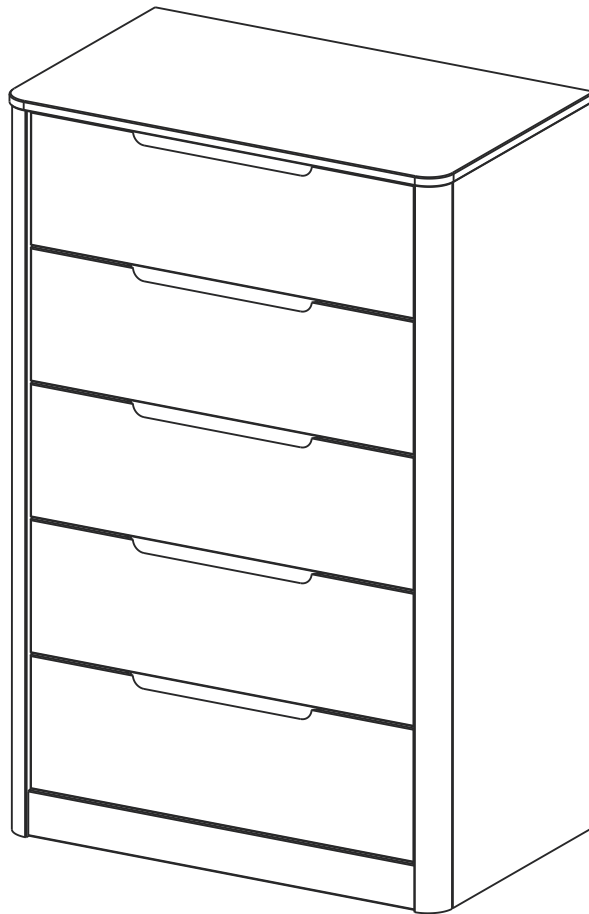

For Residential Use Only

# Time to get started

Set up a clean and soft workplace to avoid damage during assembly. You can use the box and internal protections as a cover. It also helps to double-check if you have got all the pieces and parts before diving into the assembly.

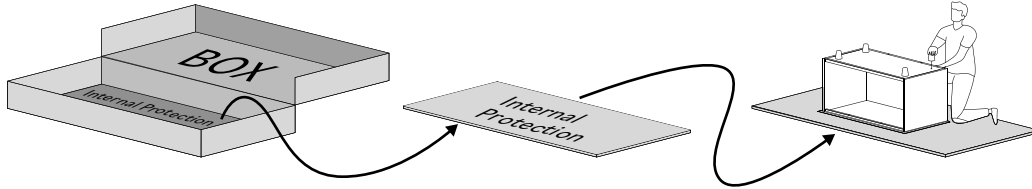

**Estimated time  
for assembly**

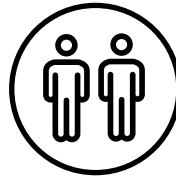

2 People Build

**People recommended**

**for assembly**

Make it a team effort!  
Grab a friend for quicker,  
easier assembly.

## Tools Needed

Grab a Phillips head screwdriver and a hammer to conquer this assembly.

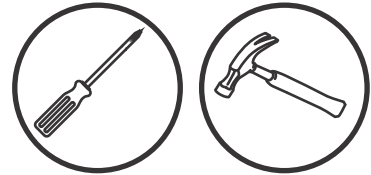

## Use power tools with caution

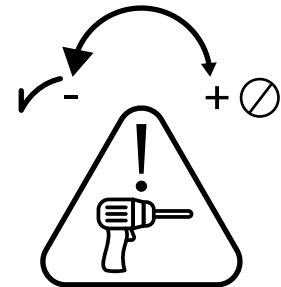

This furniture is made of Solid Wood and Composite Wood, soft materials. If you choose to use power tools, set it to the slower setting. Be careful! Power tools can cause cracking or damage to the furniture, they can also damage the hardware if misused.



# Parts List







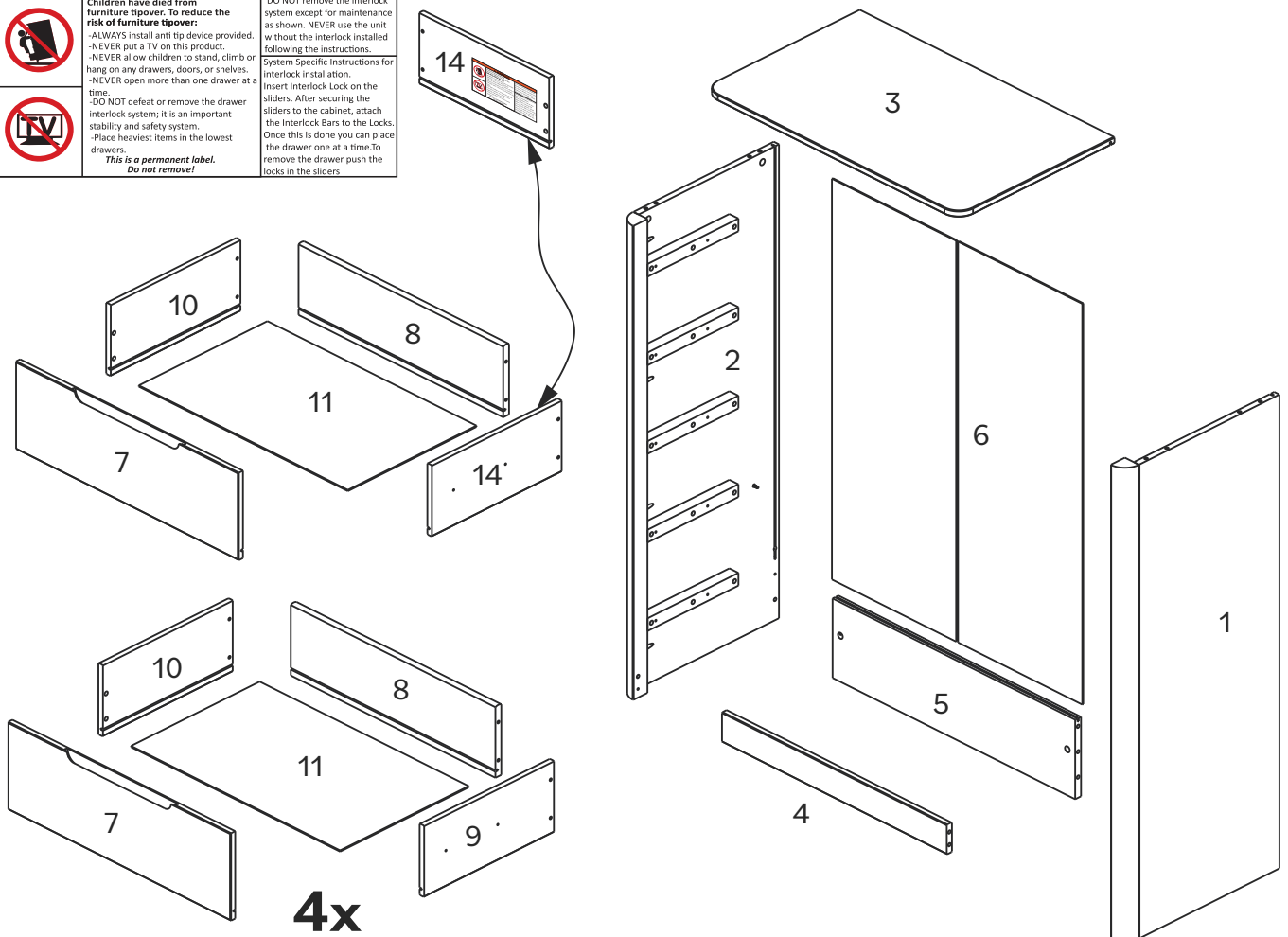









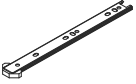

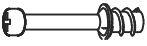
Part Number	Description	Quantity
1	Right Panel	1
2	Left Panel	1
3	Top Panel	1
4	Front Rail	1
5	Back Rail	1
6	Back Panel	1
7	Drawer Front	5
8	Drawer Back	5
9	Right Drawer Side	4
10	Left Drawer Side	5
11	Drawer Bottom	5
14	Right Drawer Side With Warning	1

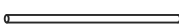
The drawer side with **WARNING LABEL**, should be placed as the highest drawer.

▲ WARNING	
	<p>Children have died from furniture tipover. To reduce the risk of furniture tipover:</p> <ul style="list-style-type: none"> <li>-ALWAYS install anti tip device provided.</li> <li>-NEVER put a TV on this product.</li> <li>-NEVER allow children to stand, climb or hang on any drawers, doors, or shelves.</li> <li>-NEVER open more than one drawer at a time.</li> </ul>
	<p>DO NOT remove the interlock system except for maintenance as shown. NEVER use the unit without the interlock installed following the instructions. System Specific Instructions for interlock installation. Insert Interlock Lock on the sliders. After securing the sliders to the cabinet, attach the Interlock Bars to the Locks. Once this is done you can place the drawer one at a time. To remove the drawer push the locks in the sliders.</p>
	<p>-DO NOT defeat or remove the drawer interlock system; it is an important stability and safety system.</p> <ul style="list-style-type: none"> <li>-Place heaviest items in the lowest drawers.</li> </ul> <p><i>This is a permanent label. Do not remove!</i></p>



# Hardware List

Part	Size	Name	Quantity
A		Dovetail	10
B		Dovetail Lock	20
C		Plastic Screw	20
D	 6x12mm	Screw	20
E		Interlock Lock	10
F	 6x20mm	Screw	20
G1	 250mm	Outer Slider	10
G2	 250mm	Inner Slider	10
H	 8x30mm	Wooden dowel	10
I	 6x31mm	Cam bolt	8
J	 15x11mm	Cam Lock	8
K		Interlock Bar	4
L		Wedge	12
M		Wall anchor	1
N	 4x16mm	Screw	1
O	 6x35mm	Plastic bush	1
P	 4x40mm	Screw	1
Q		Washer	2
R	 3,5X14mm	Screw	12

*The hardware quantities listed above are required for proper assembly.  
Extra hardware pieces may be included.*

# Introducing The Easy Assembly Drawer System

## Say Goodbye to Assembly Hassle!

We understand that assembling drawers can be the most time-consuming and tedious part of putting together your new furniture. That's why we've developed the Easy Assembly Drawer System - to make the process easy!

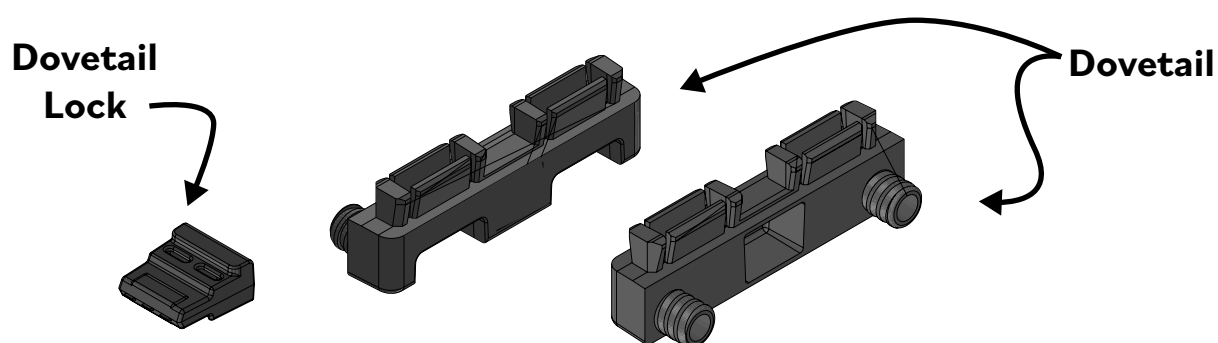

### Why You'll Love Our Easy Assembly Drawer System:

**Quick & Easy:** Our new drawer hardware significantly reduces your assembly time. Get it done in no time!

**Minimal Effort Required:** Designed to be super simple, you'll need little to no tools to get the job done.

**Built to Last:** Strong and sturdy, our system ensures that your drawers stay solid and reliable.

### Let's set the stage to assembly:

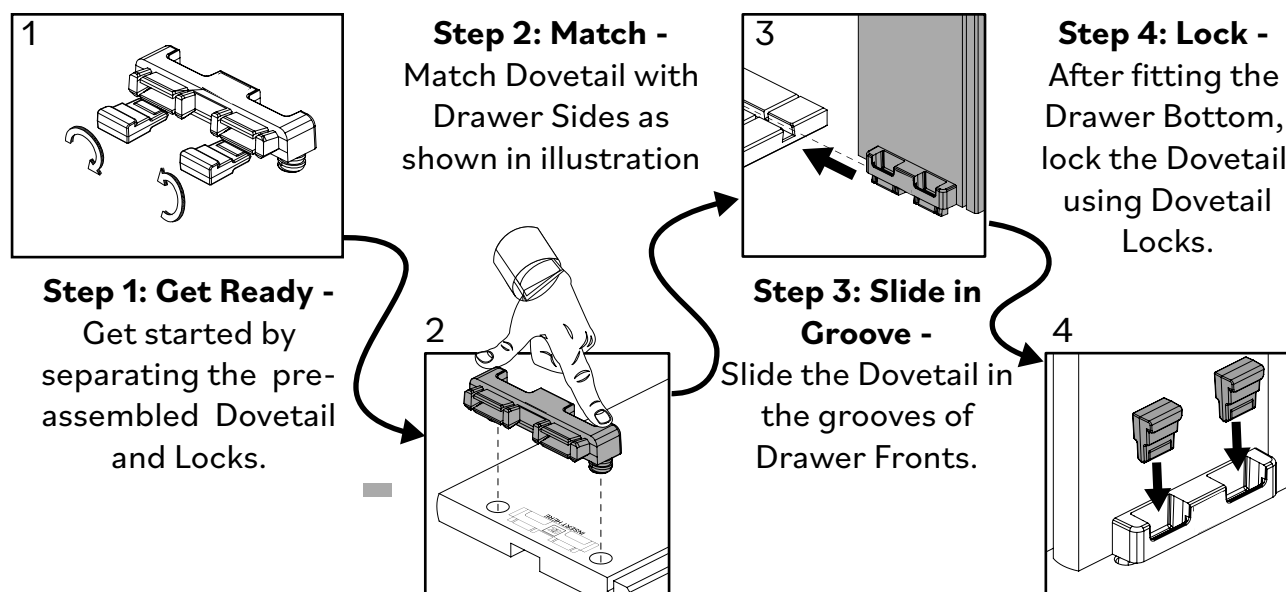

**Attention:** In the next steps there are more details to help you assemble.

# Step 1

Prepare the Dovetails (A) by removing the Dovetail Locks (B) from the Dovetails (A).

**1st**

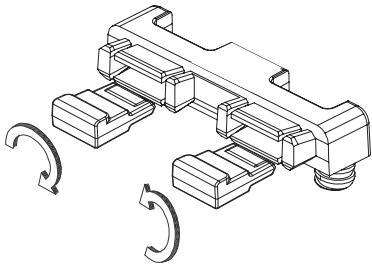

**2nd**

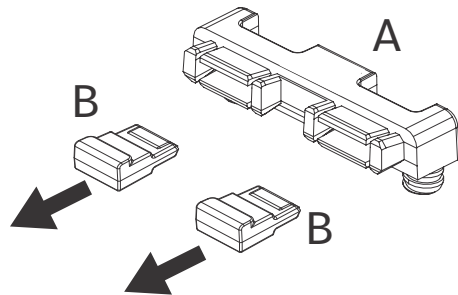

# Step 2

Snap the Dovetails (A) into place on Right Drawer Sides (9 and 14) and Left Drawer Sides (10). Press the Dovetails until they are completely attached. Use a hammer if necessary.

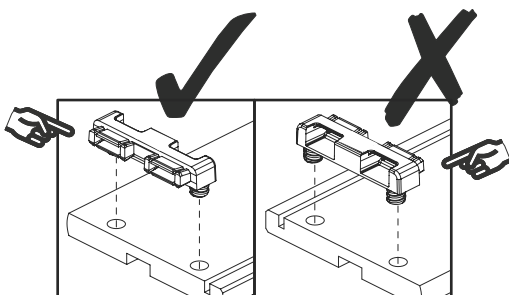

Press the piece until it is completely attached

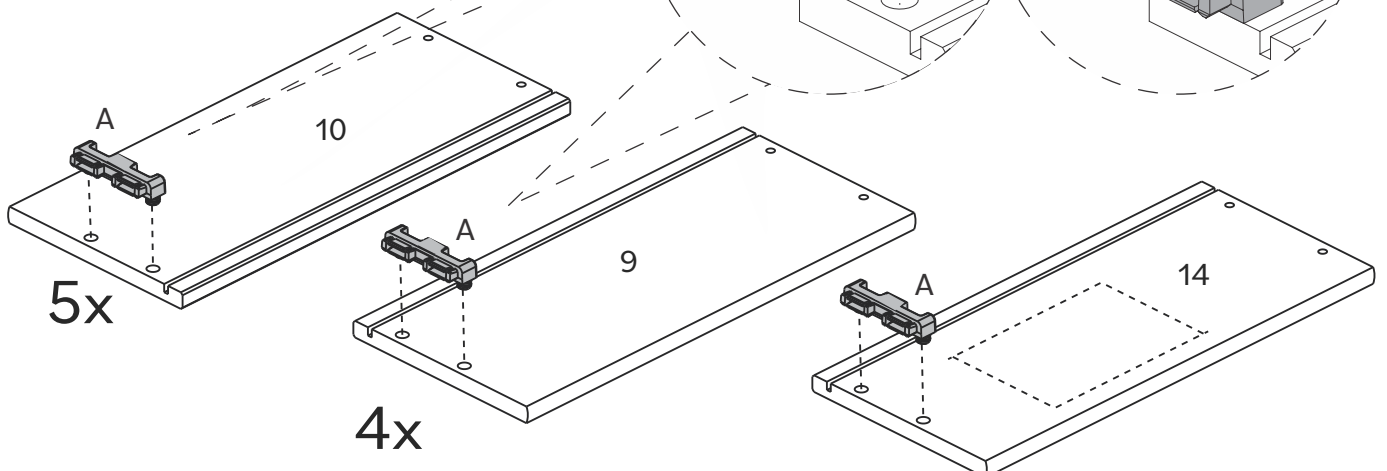
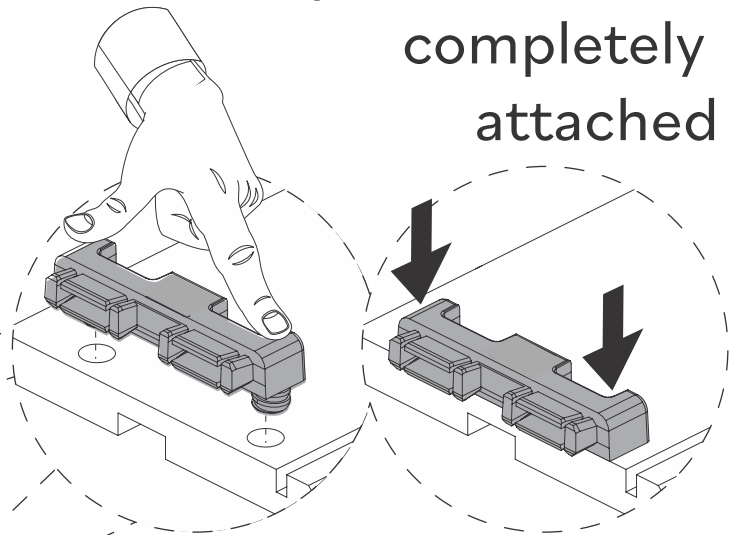

# Step 3

Slide the Dovetail (A) on the Right Drawer Panel (9/14) and Left Drawer Panel (10) into the grooves on the Drawer Front (7).

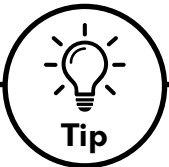
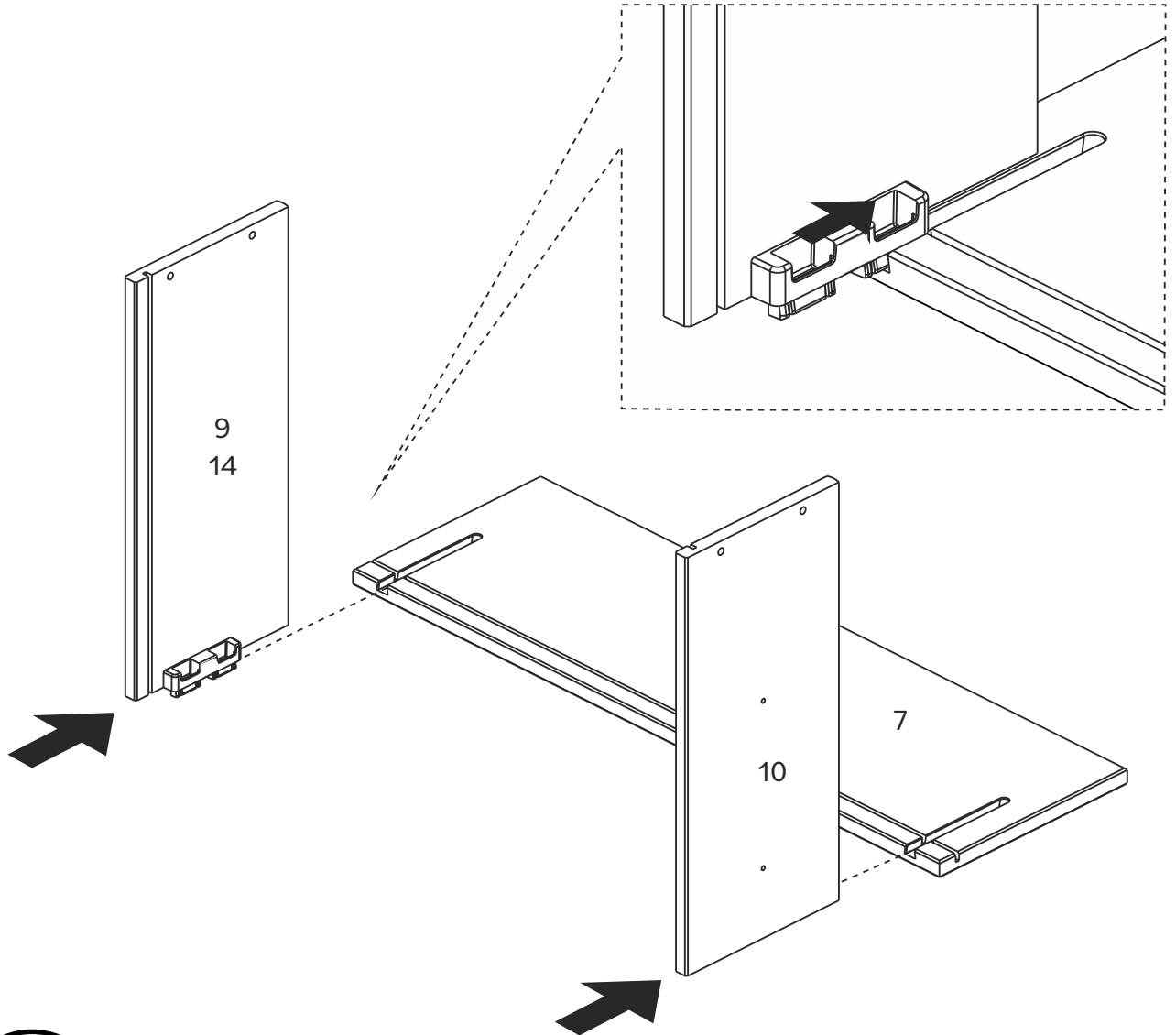

## Tip

To keep your product looking its best and scratch-free, try assembling it on a soft surface like carpet or a blanket. This helps prevent any accidental scratches and keeps your furniture in top shape!

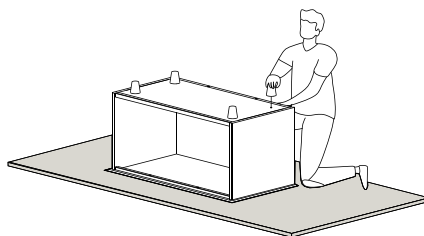

# Step 4

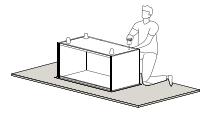

Slide Drawer Bottom (11) between the grooves on Right Drawer Side (9 and 14) and Left Drawer Side (10) fitting in Drawer Front (7).

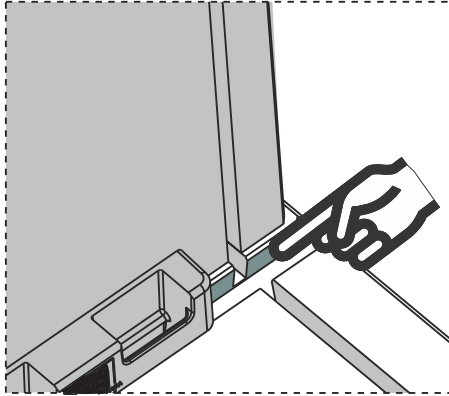

Align the grooves on the Drawer Sides and Drawer Front to receive the Drawer Bottom

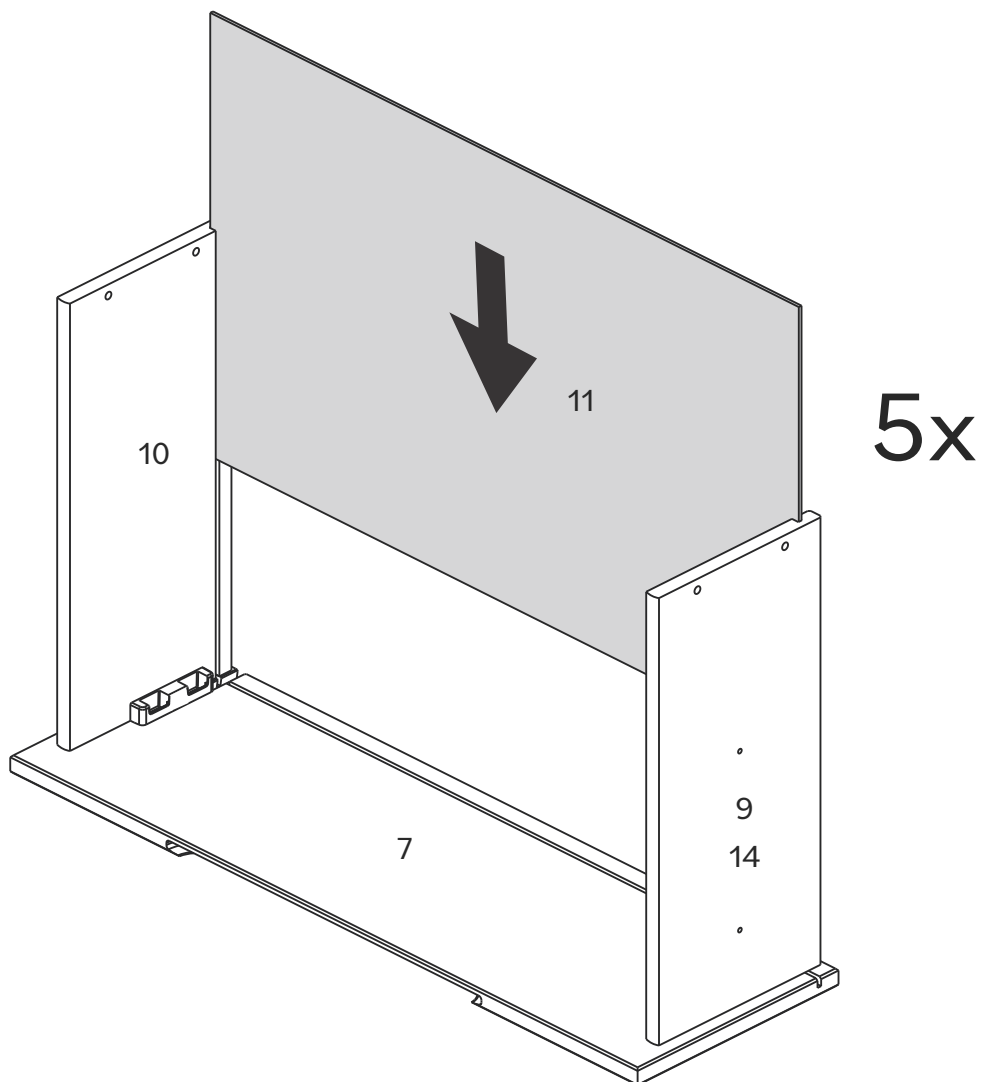

# Step 5

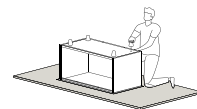

To secure the Drawer sides, insert the Dovetail Locks (B) into the Dovetails (A). Use a hammer if necessary.

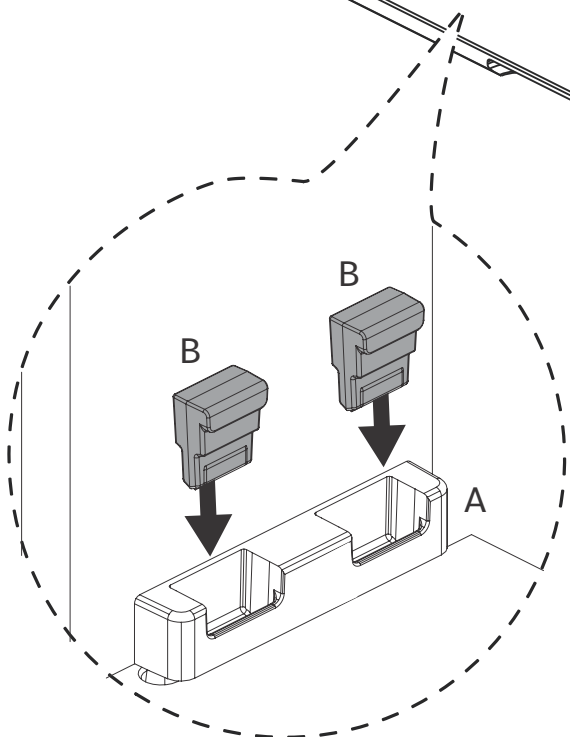
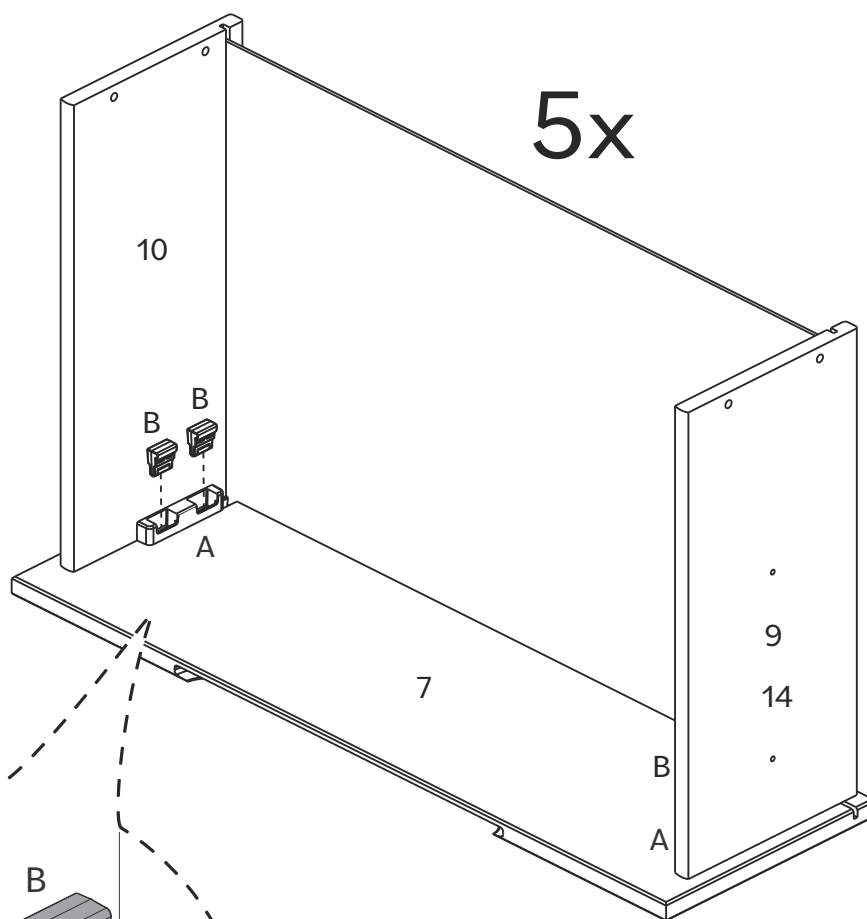

Once this step is completed, your product should look like this:

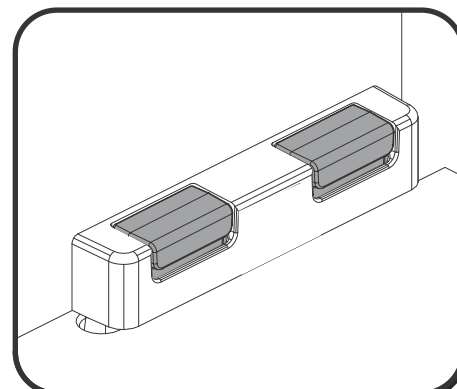

# Step 6

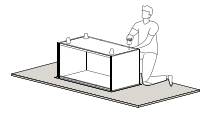

Fit Drawer Bottom (11) to Drawer Back (8) and secure using Plastic Screw (C), you can insert it with your hands or using a hammer.

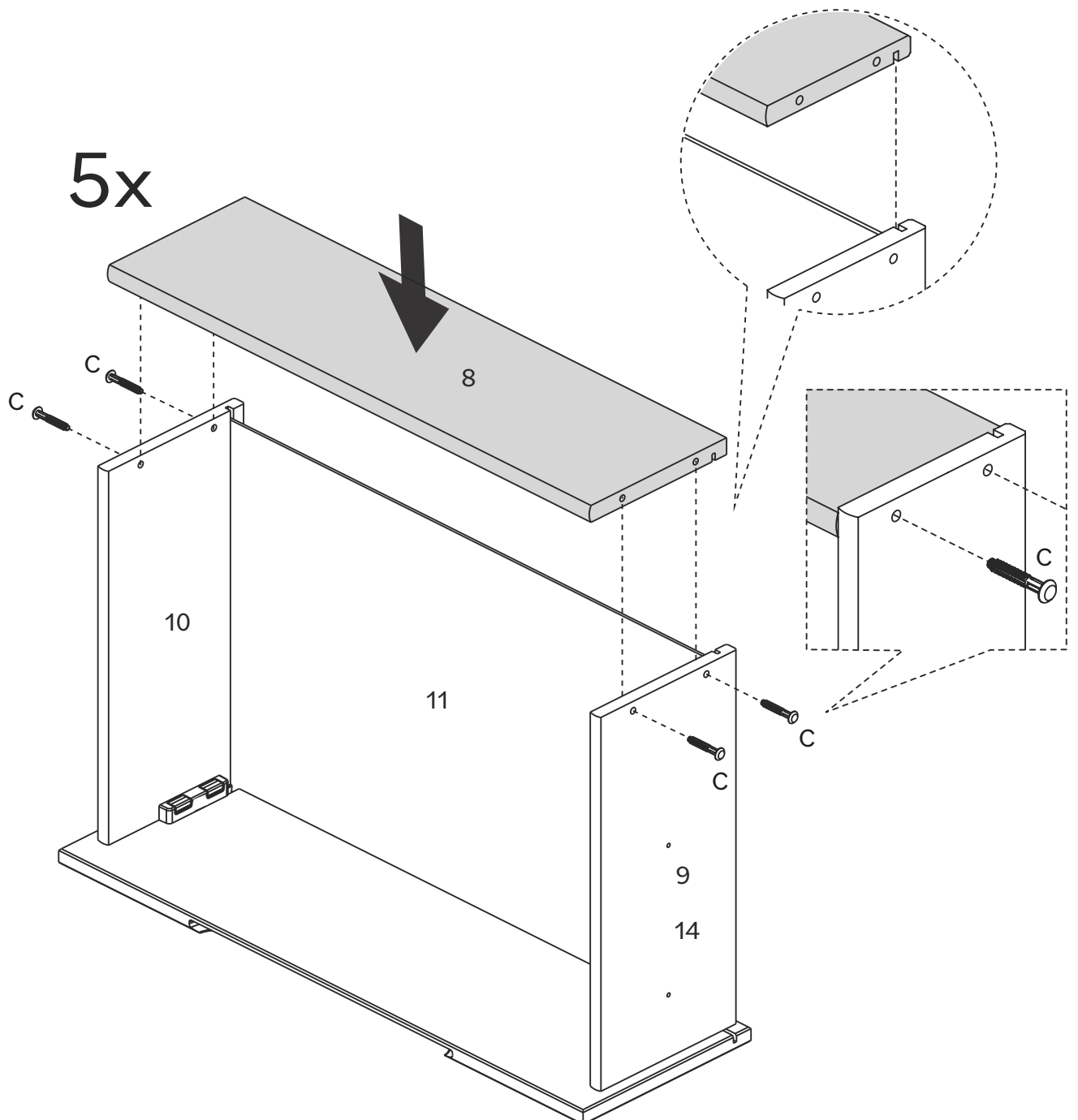

# Step 7

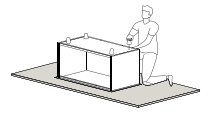

Attach Inner Sliders (G2) to Right Drawer Sides (9 and 14) and Left Drawer Sides (10) using Screw (D) and a Phillips

Separate parts G1 and G2 by pressing the lock.

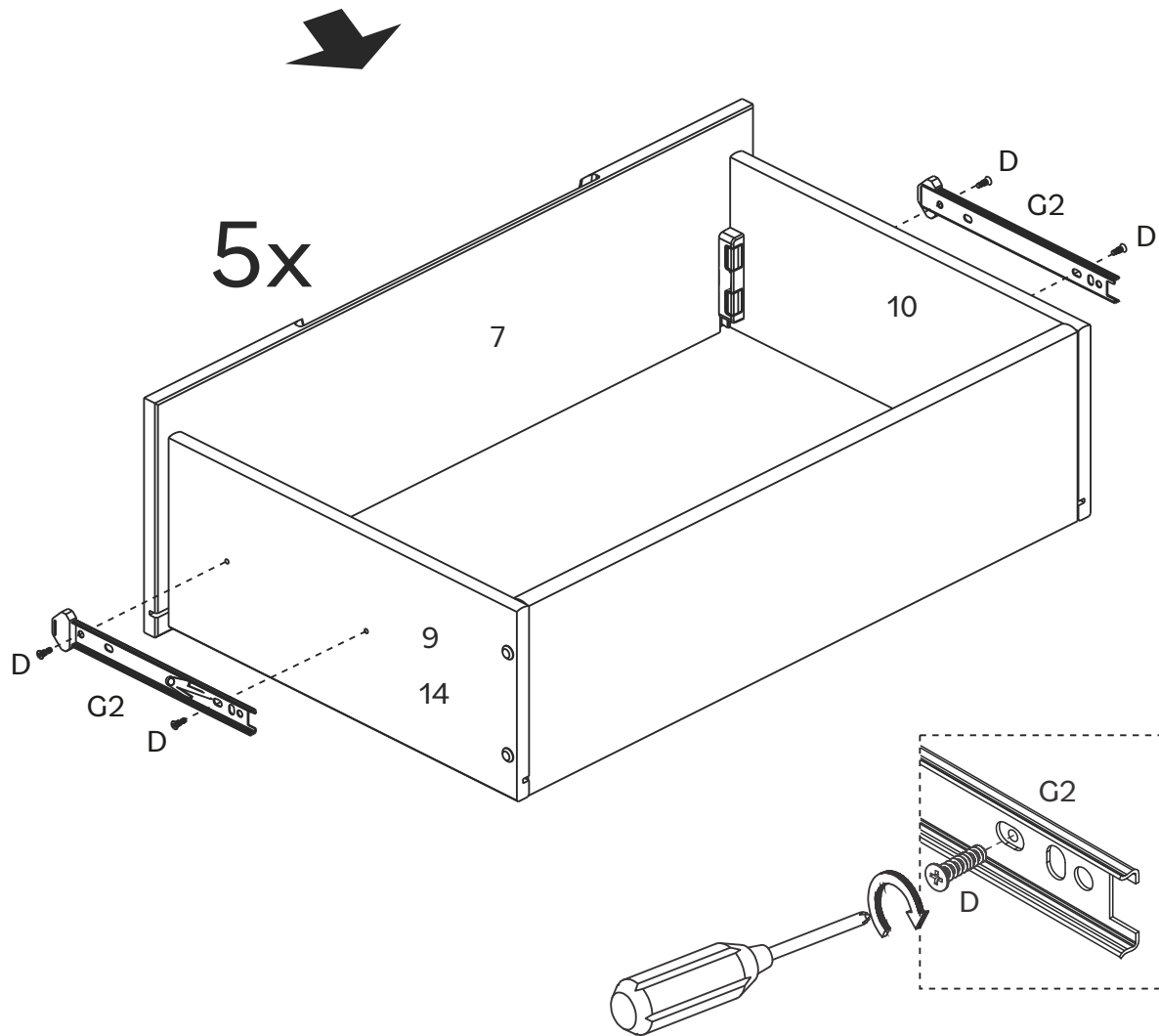
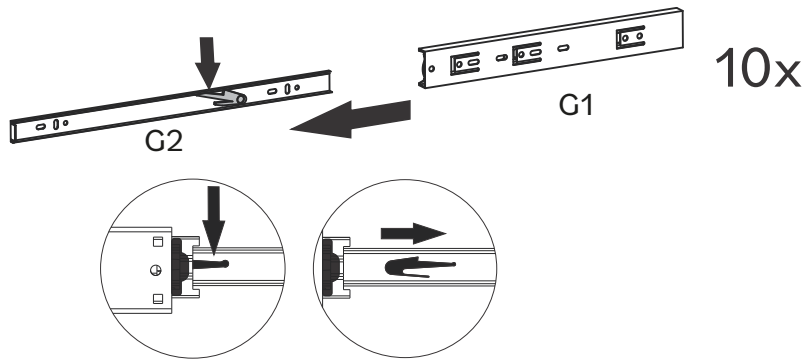

# Step 8



Drawers assembled, let's get started on the Chest! Insert Wooden Dowels (H) into Right Panel (1), Left Panel (2), Back Rail (5), and Front Rail (4).

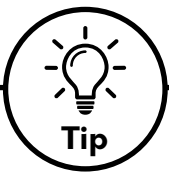
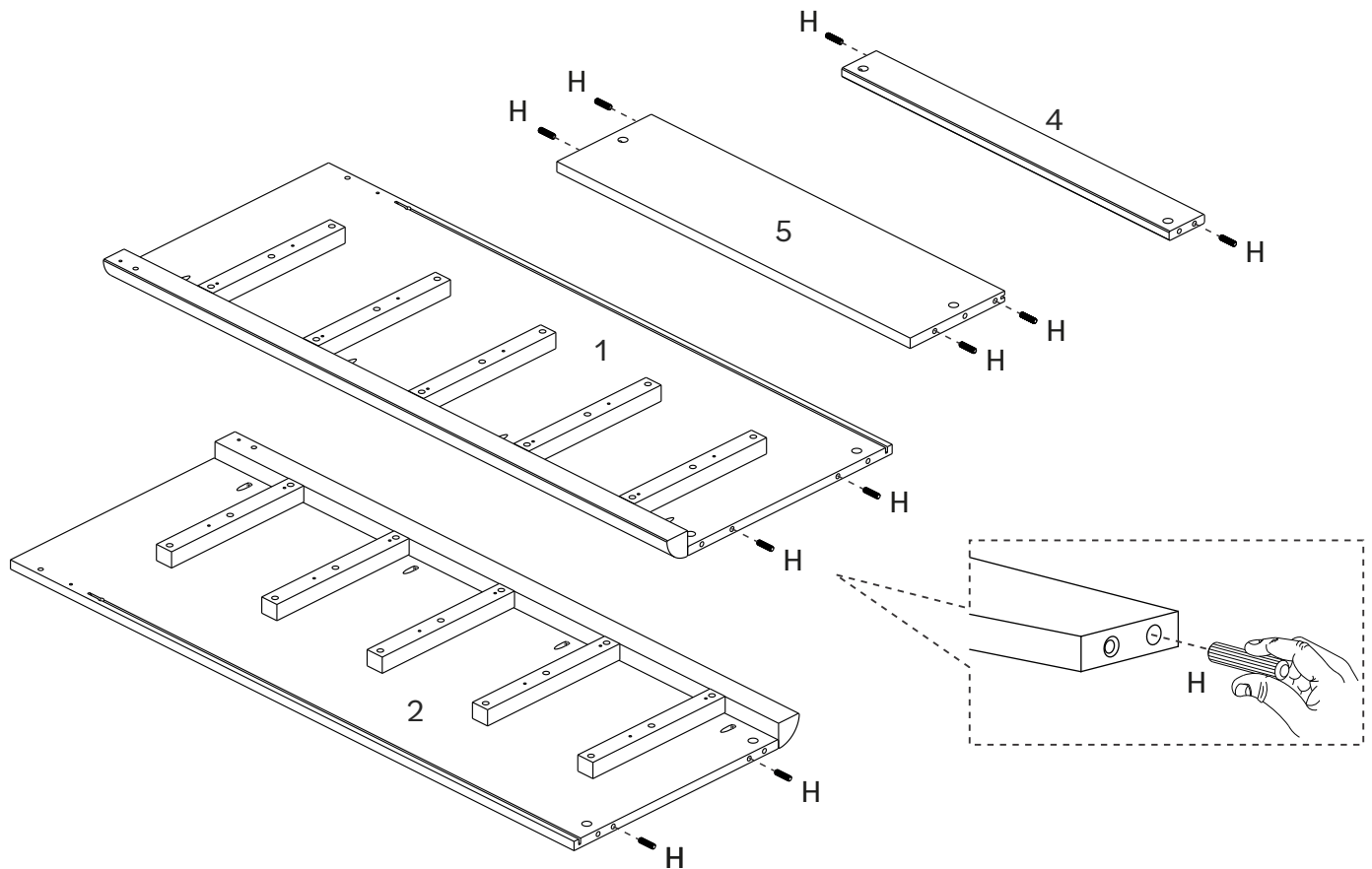

Tip

## Wood Dowels

Dowels are essential in furniture assembly to create strong, precise connections. They ensure structural integrity, prevent shifting, and simplify alignment, resulting in sturdier, longer-lasting furniture.

Follow these steps:

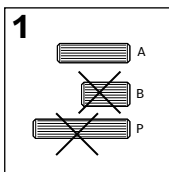

1: Select the appropriate size dowel according with step.

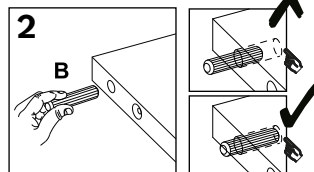

2: Insert into drilled hole and press firmly to ensure placement is set.

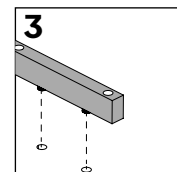

3: Align the dowel with corresponding piece and press together until secure.

# Step 9



Attach Cam Bolts (I) to Right Panel (1), Left Panel (2) and Top Panel (3) using a Phillips screwdriver.

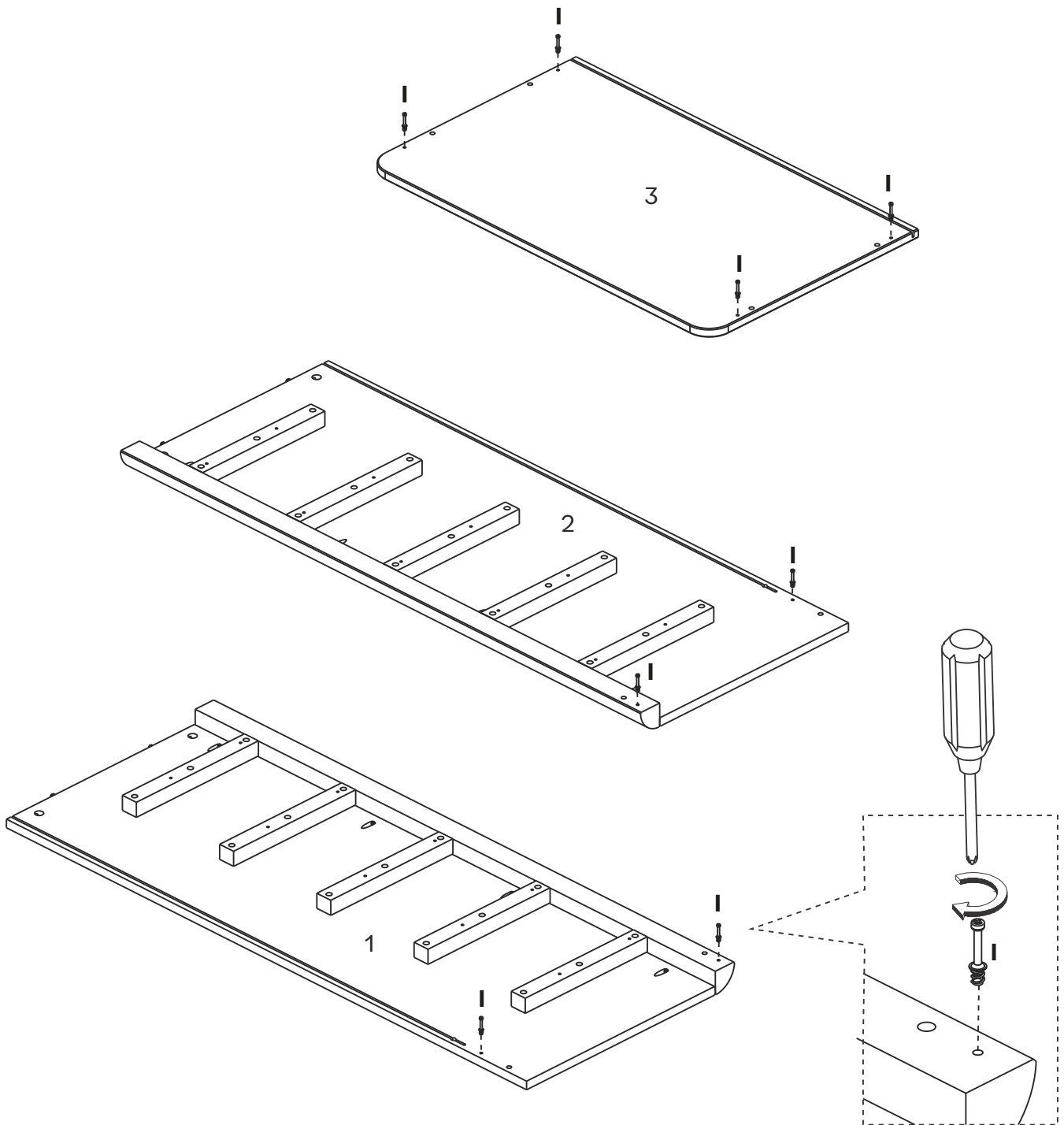

# Step 10

Take Outer Slider (G1) and insert Interlock Lock (E) according to the diagram below.

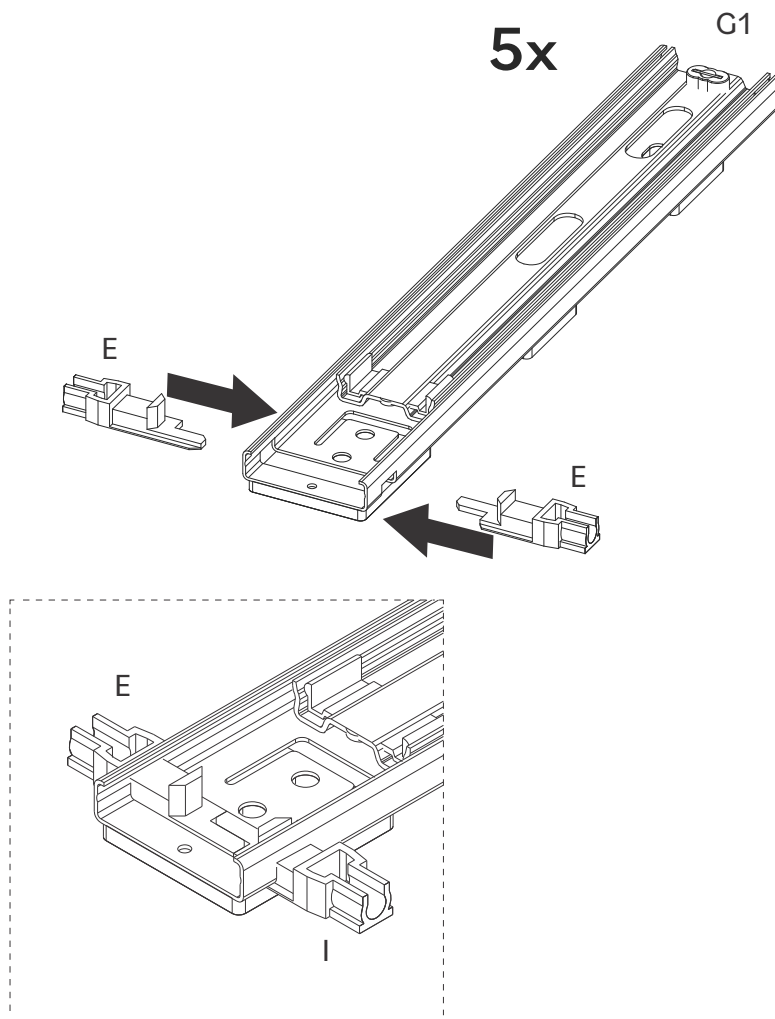

# Step 11



Secure Outer Slider (G1) to Right Panel (1) and Left Panel (2) using Screw (F) and a Phillips screwdriver.

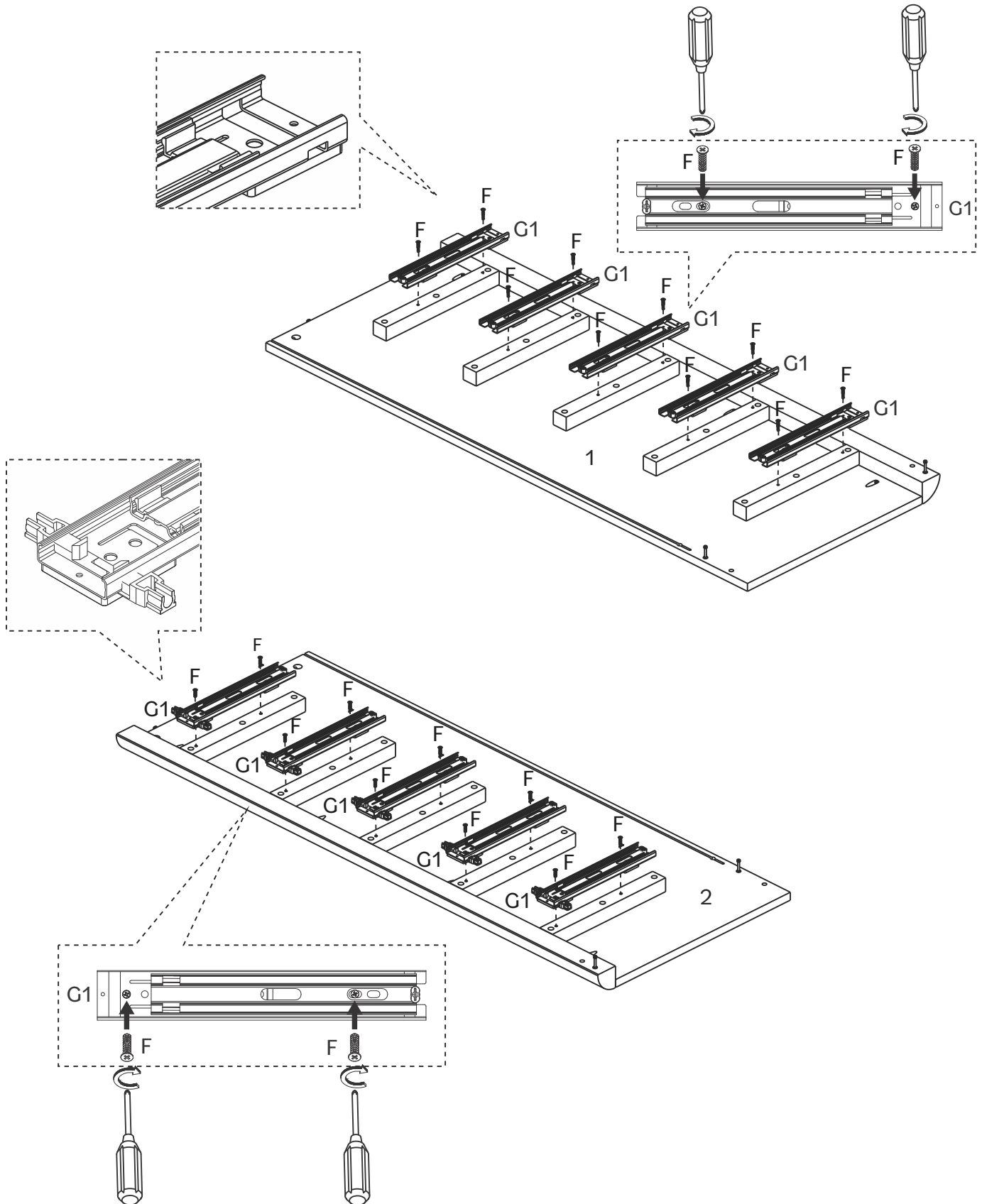

# Step 12



Attach Front Rail (4) and Back Rail (5) to Right Panel (1) using Cam Locks (J) and a Phillips screwdriver.

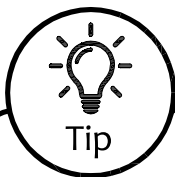
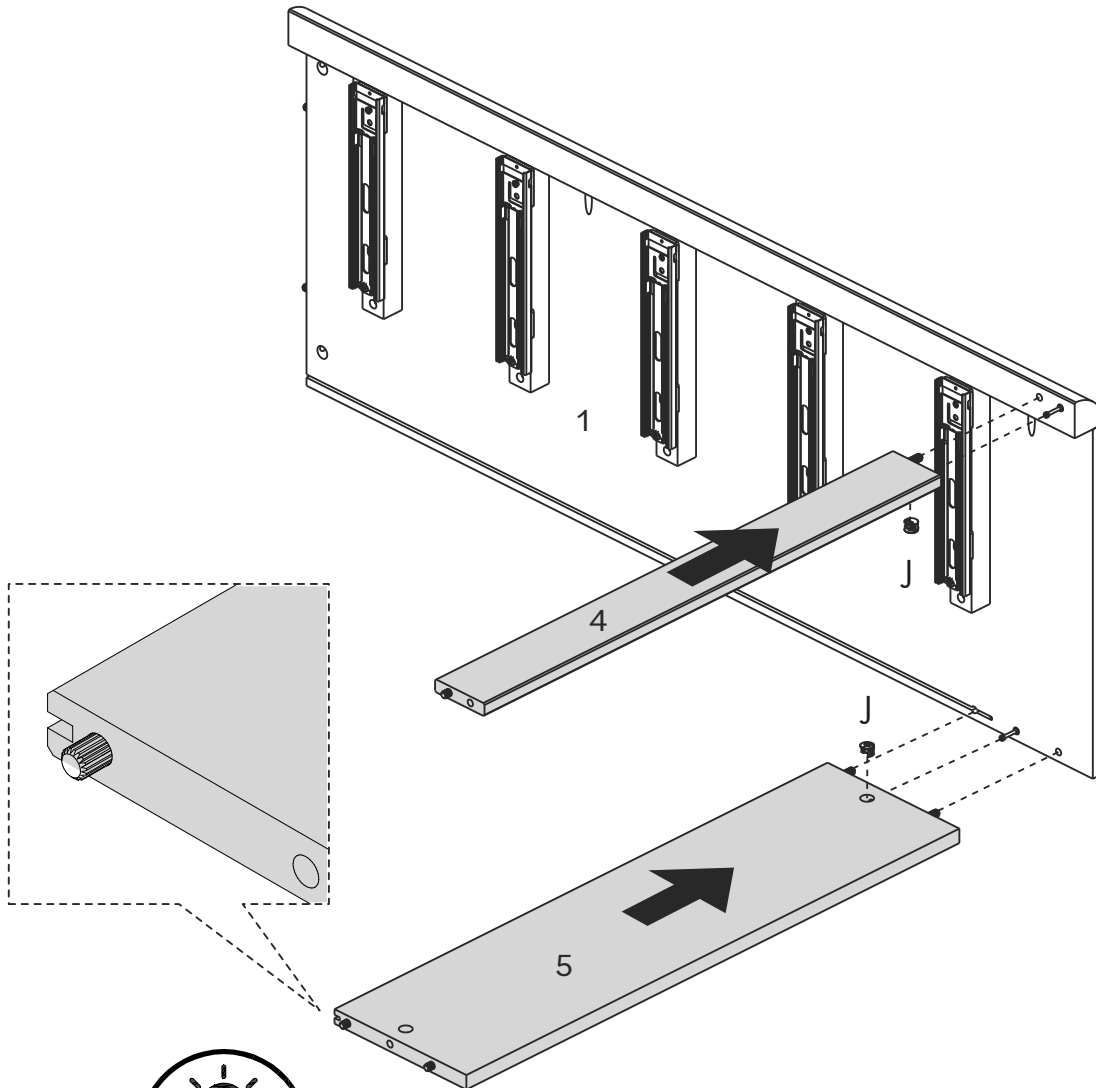

Tip

## Cam Locks

Cam Locks help to securely join two pieces together. Follow these easy steps.

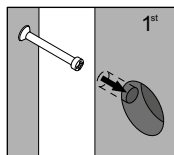

1: Insert Cam Bolt into bolt holes on the flat side. Don't over tighten!

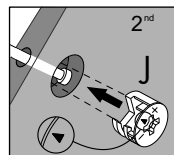

2: Assemble both parts together. The cam bolts go in the drill holes that have a circular hole on the side, you should be able to see the cam bolts through it. After fitting parts together insert the cam lock on the side holes.

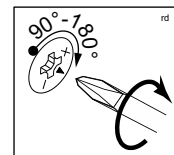

3: On the back of the Cam Lock will be a "C" shape. Insert the Cam Lock so the opening of the "C" fits over the Cam Bolt. Tighten with the screwdriver.

# Step 13



Join Left Panel (2) using Cam Locks (J) and a Phillips screwdriver.

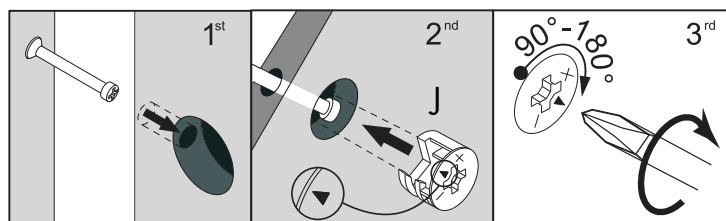
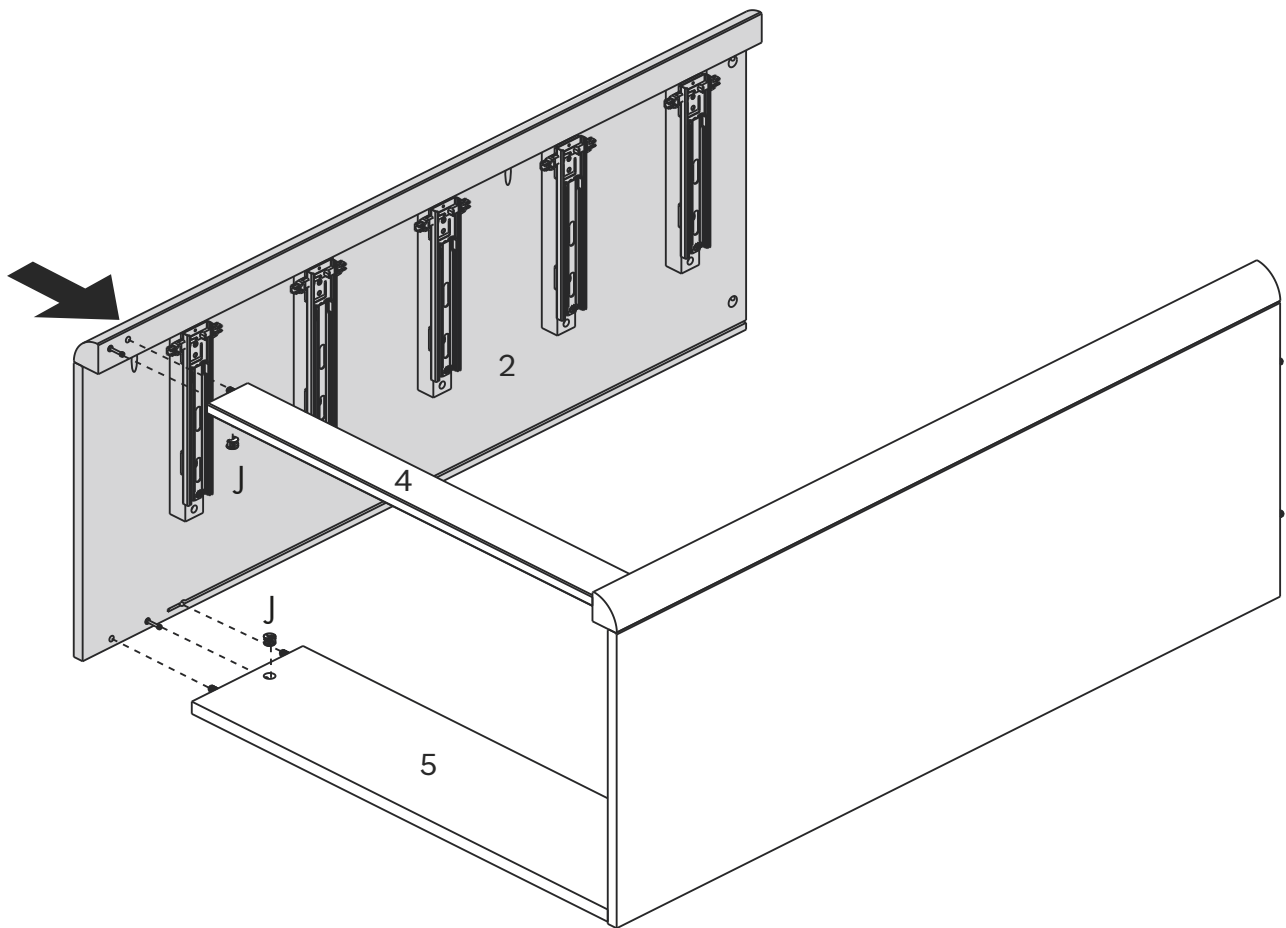

# Step 14

Slide Back Panel (6) on the grooves on Right and Left Panel (1 and 2) and fit in Back Rail (5).

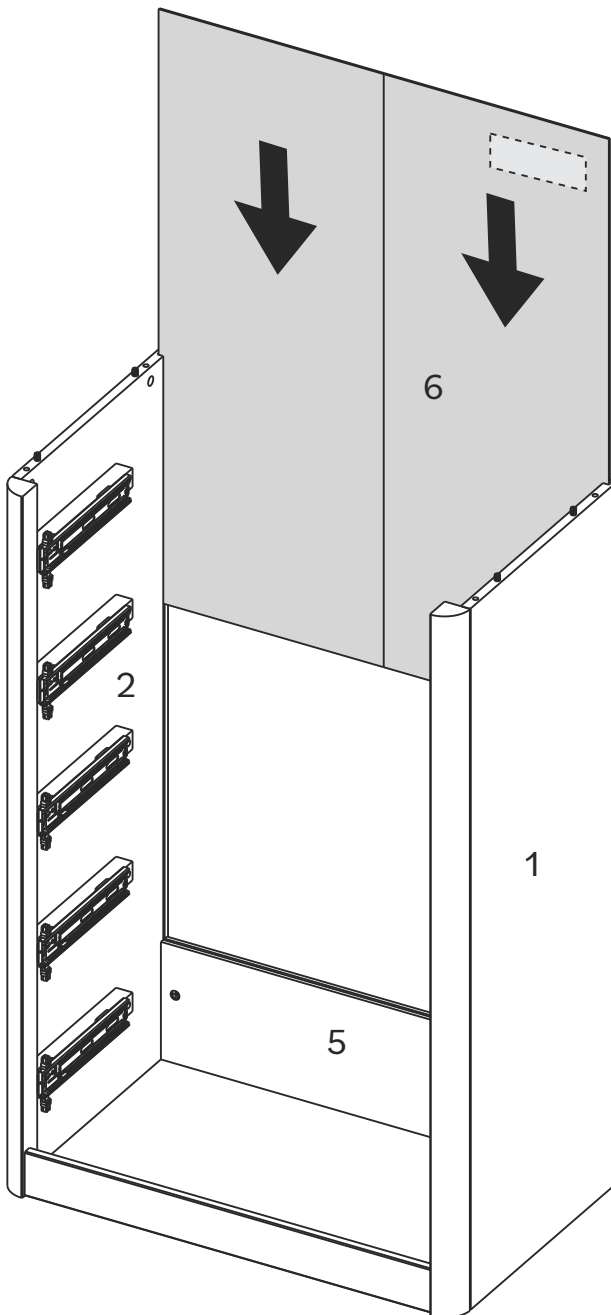
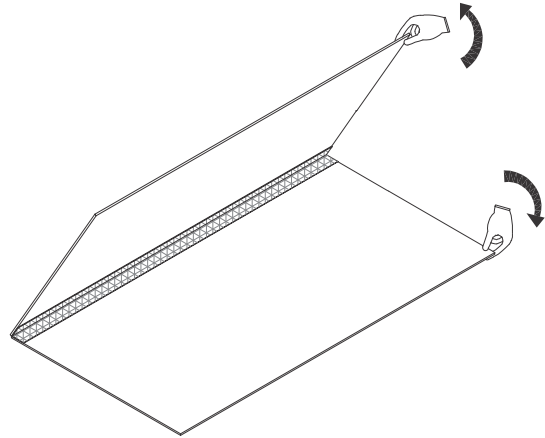

**Traceability label  
should be facing  
outward**

Name and address of  
the supplier and date  
of production.

# Step 15

Secure Top Panel (3) using Cam Locks (J) and a Phillips screwdriver.

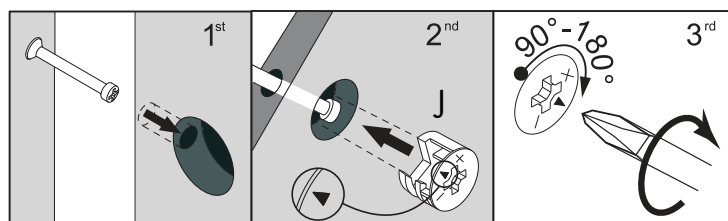
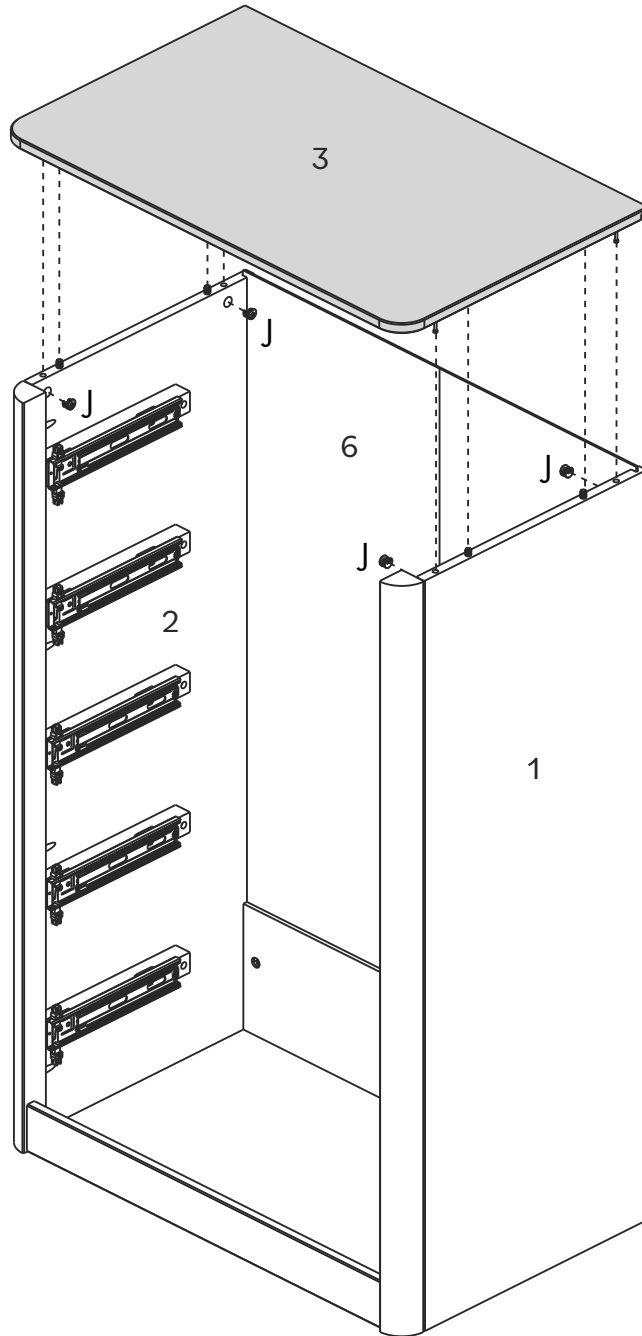

# Step 16

Attach Interlock Bars (K) into the Interlock Locks (E).

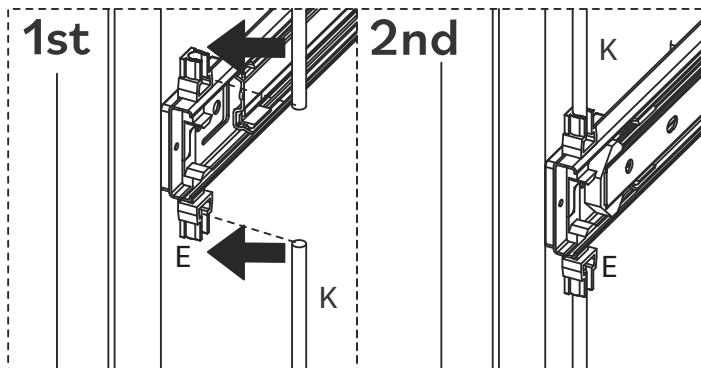
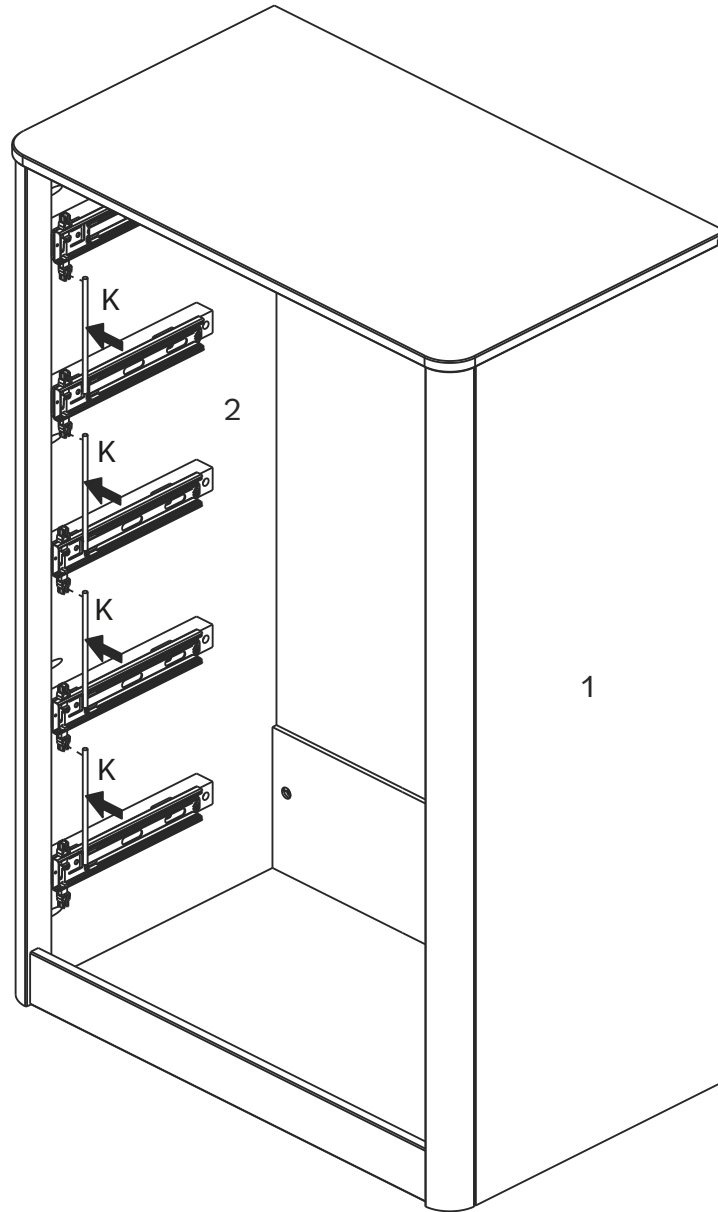

# Step 17

Secure Back Panel (6) fitting Wedge (L) and screw (R) between the panel and the grooves. Use and a Phillips screwdriver.

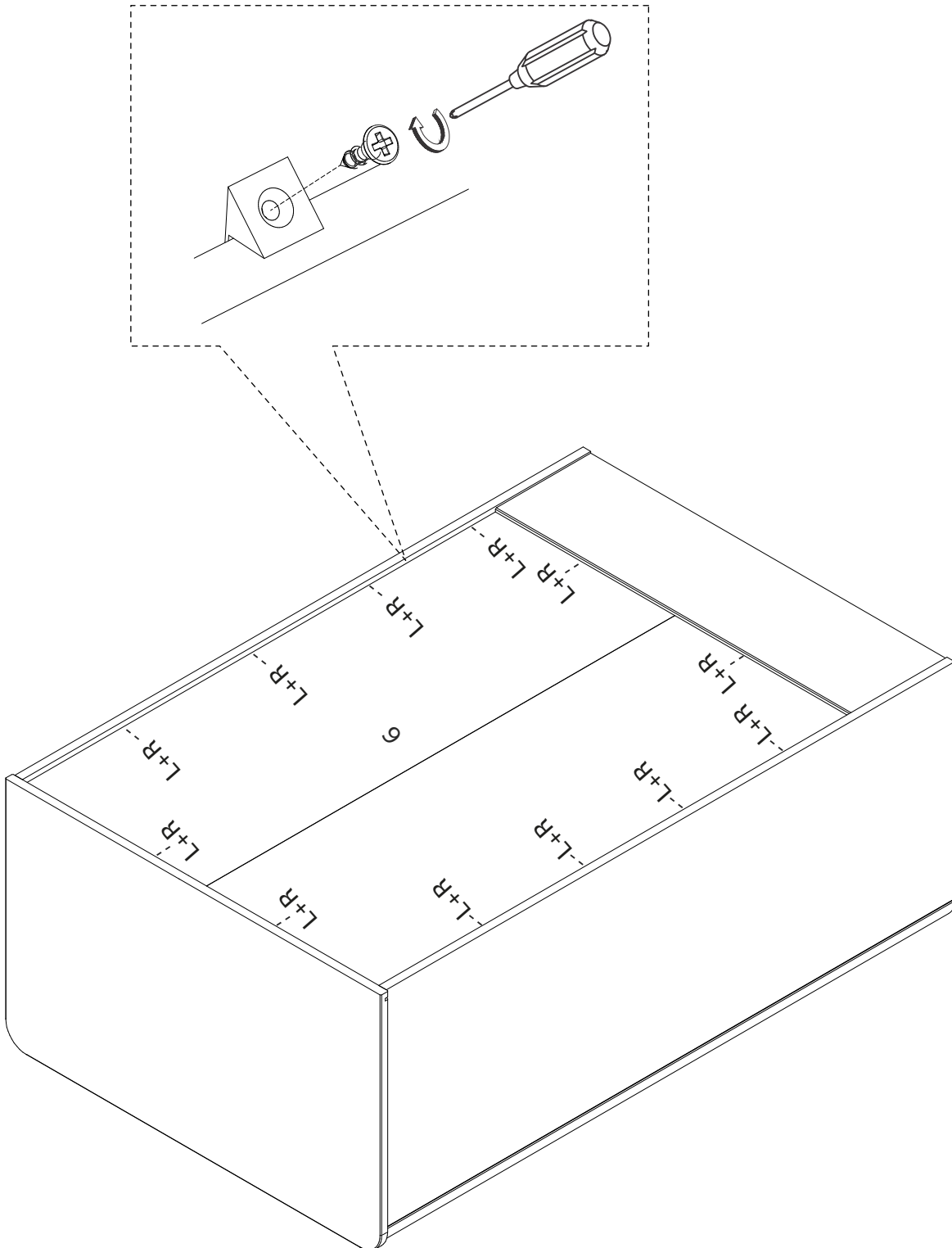

# Step 18

Place the Drawers one at a time using the sliders, pay attention to position them correctly aligning Outer and Inner Slider.

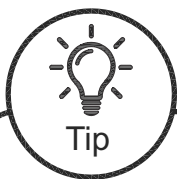
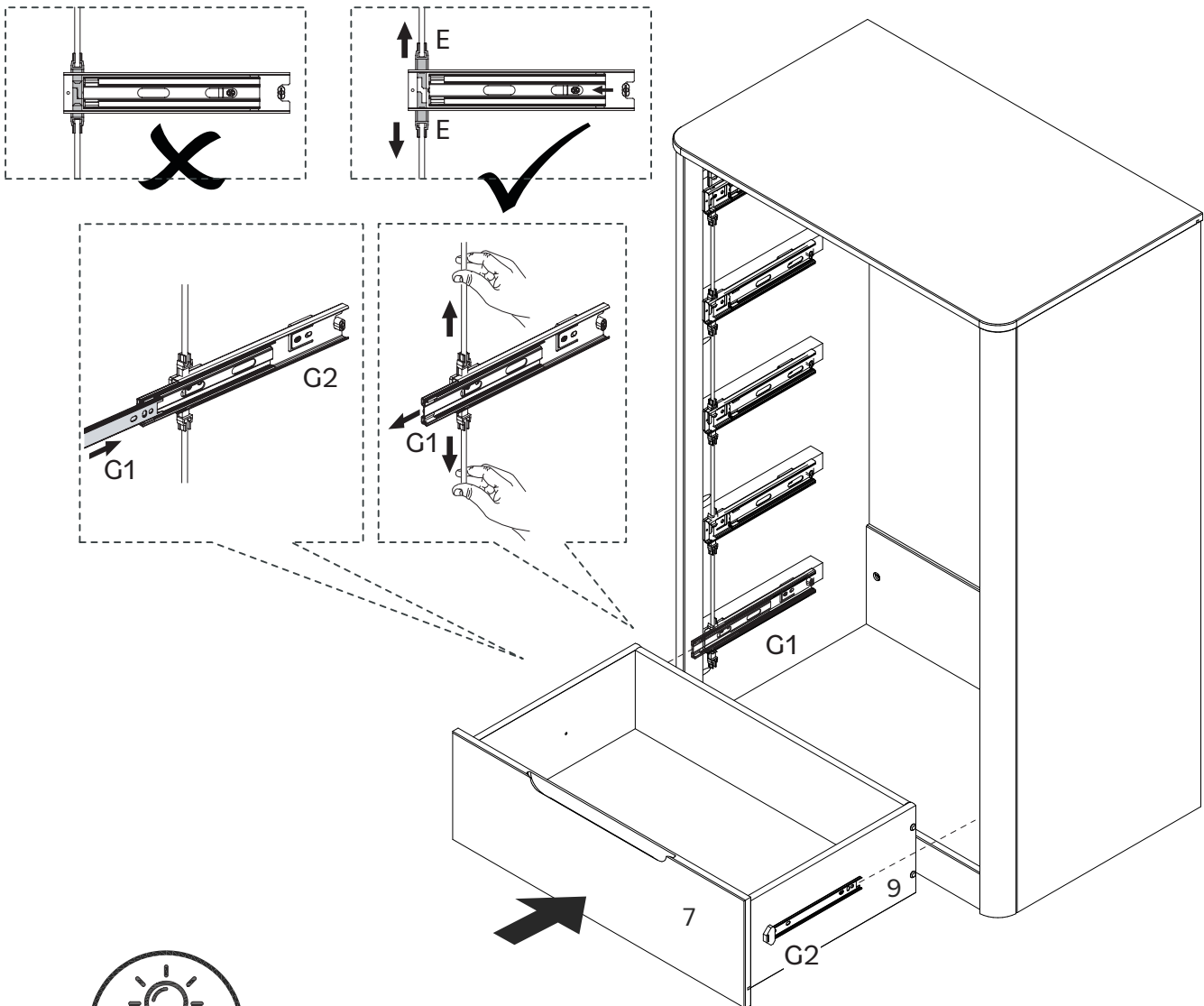

Tip

## Insert your Cabinet Drawer Correctly

Line up Outer and Inner Slider and push the drawer slightly inside the unit, once you feel the connection push the drawer entirely into place. It may not be a smooth gliding at first, but it improves once fully connected.

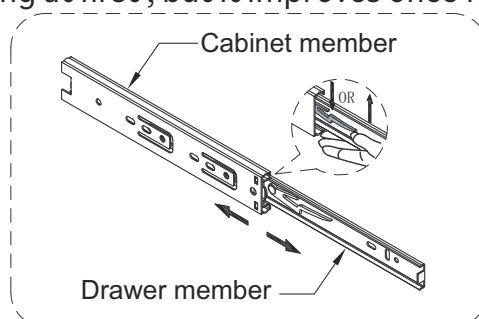

# Step 19

Place the Drawers one at a time using the sliders, pay attention to position them correctly aligning Outer and Inner Slider.

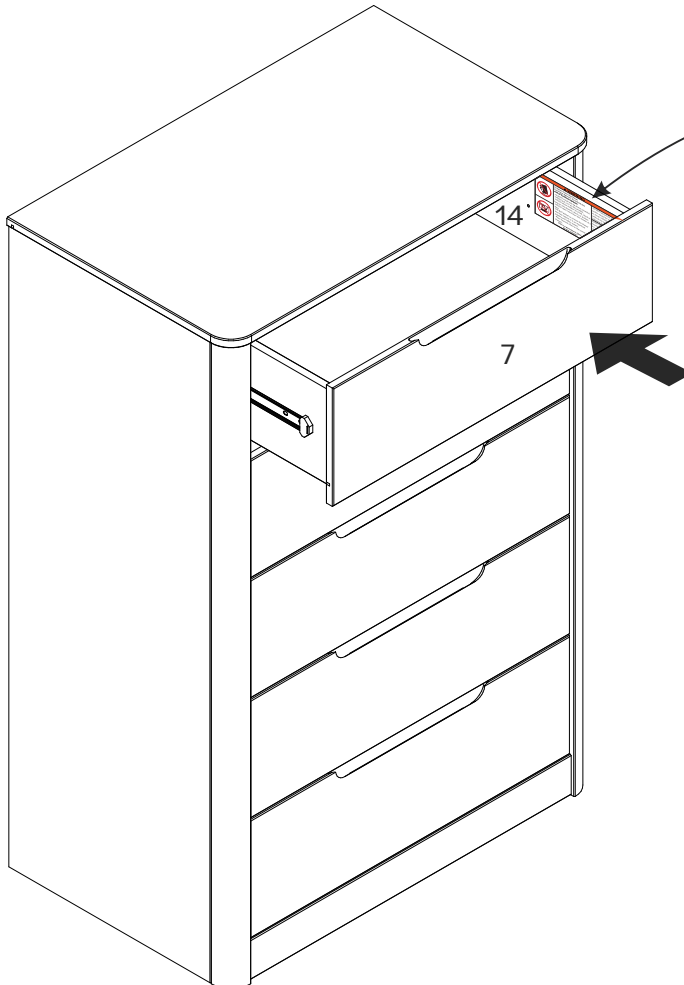

⚠ WARNING	
 <b>Children have died from furniture tipover. To reduce the risk of furniture tipover:</b> <ul style="list-style-type: none"><li>-ALWAYS install anti tip device provided.</li><li>-NEVER put a TV on this product.</li><li>-NEVER allow children to stand, climb or hang on any drawers, doors, or shelves.</li><li>-NEVER open more than one drawer at a time.</li><li>-DO NOT defeat or remove the drawer interlock system; it is an important stability and safety system.</li><li>-Place heaviest items in the lowest drawers.</li></ul> <i>This is a permanent label. Do not remove!</i>	<b>DO NOT</b> remove the interlock system except for maintenance as shown. NEVER use the unit without the interlock installed following the instructions. System Specific Instructions for Interlock installation. Insert Interlock Lock on the sliders. After securing the sliders to the cabinet, attach the Interlock Bars to the Locks. Once this is done you can place the drawer one at a time. To remove the drawer push the locks in the sliders.

The Drawer Side with Warning Label should be positioned as the highest drawer.

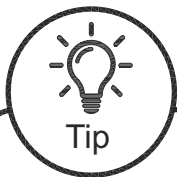
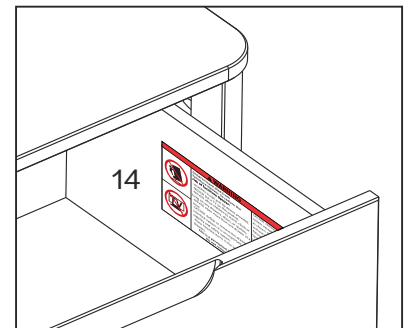

## Removing the Drawer

There is a white lever in each slider, to remove the drawers pull the drawer out until you see the lever. Push one lever up and the other down, while pushing, bring the drawer out

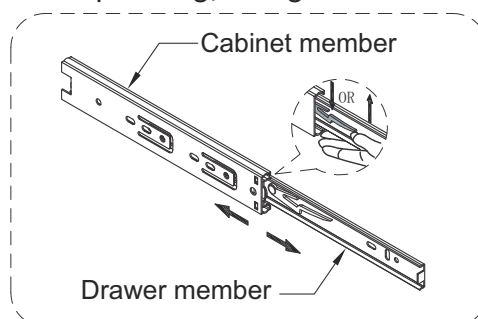

# Step 20

To finish this up, attach the anti-tipping kit. Secure Wall Anchor (M) to Top Panel (3) using Washer (Q), Screw (N) and a Phillips screwdriver following the details in the diagram below.

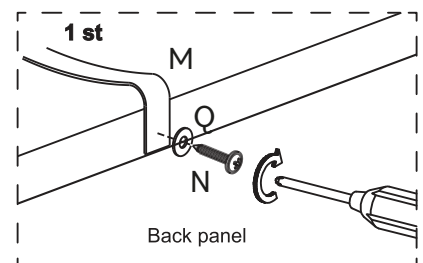
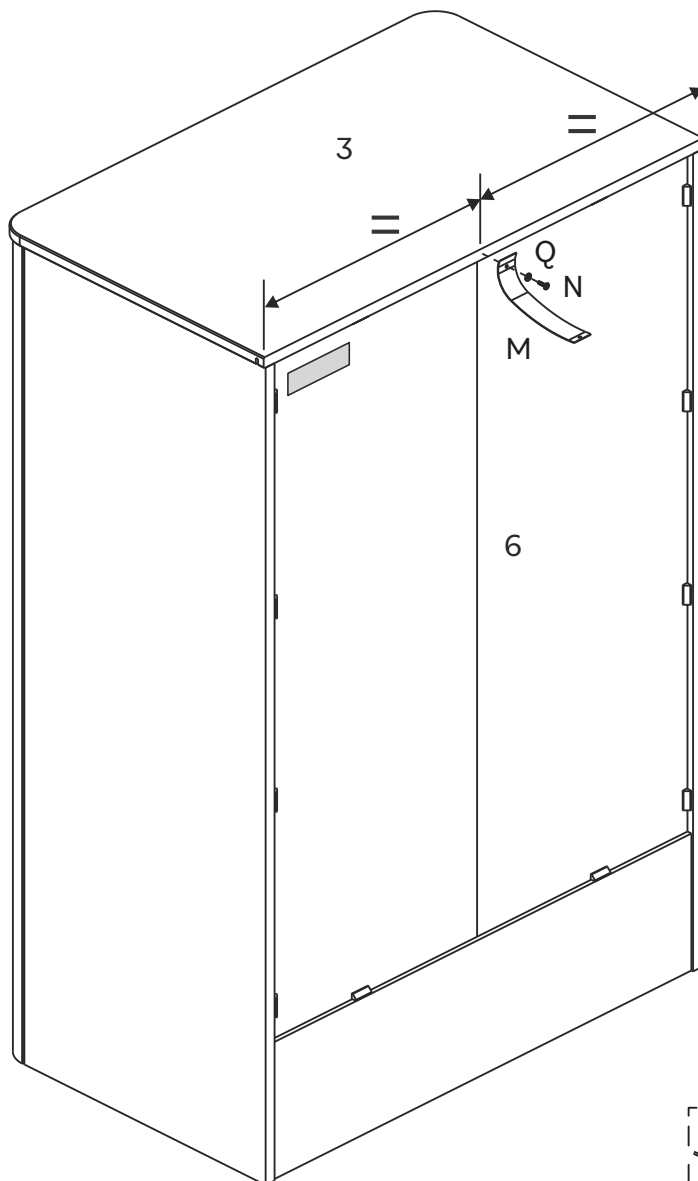

# Step 21

Last step! Insert Plastic Bush (O) into the wall. Then, secure Wall Anchor (M) to the wall using Washer (Q) and Screw (P).

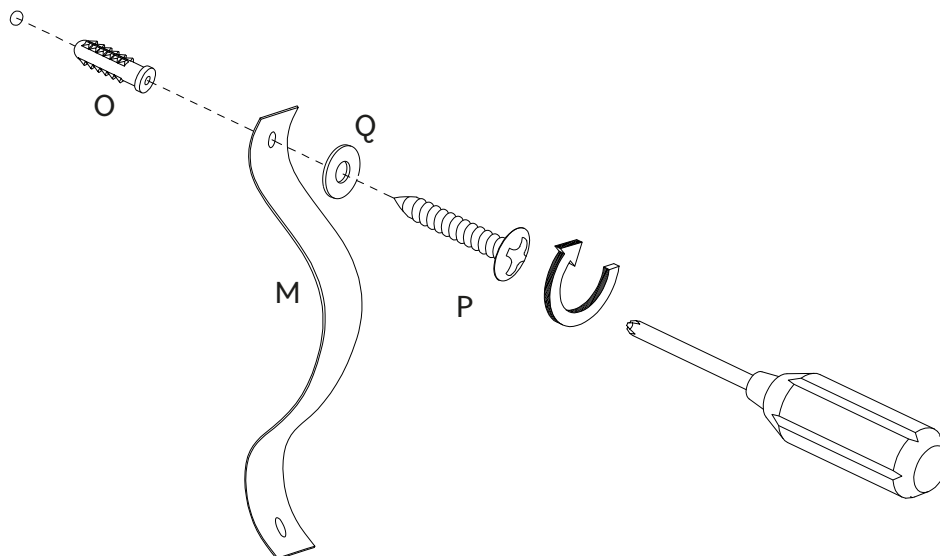
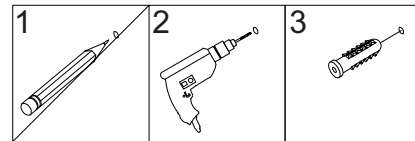

## Warning

Serious or fatal injuries can occur from furniture tipping over. To prevent the furniture from tipping over we recommend that it is permanently fixed to the wall. Wall anchor and hardware are included with this product. Please make sure hardware is suitable for your walls before installing, as different wall materials may require different types of anchors.

Name and address information for the manufacturer responsible for the anti-tip hardware and date of production can be found on the label on the back of the furniture.

# To Disassemble

If it is necessary to disassemble, remove the Dovetail locker (B) with a Slotted head screwdriver.

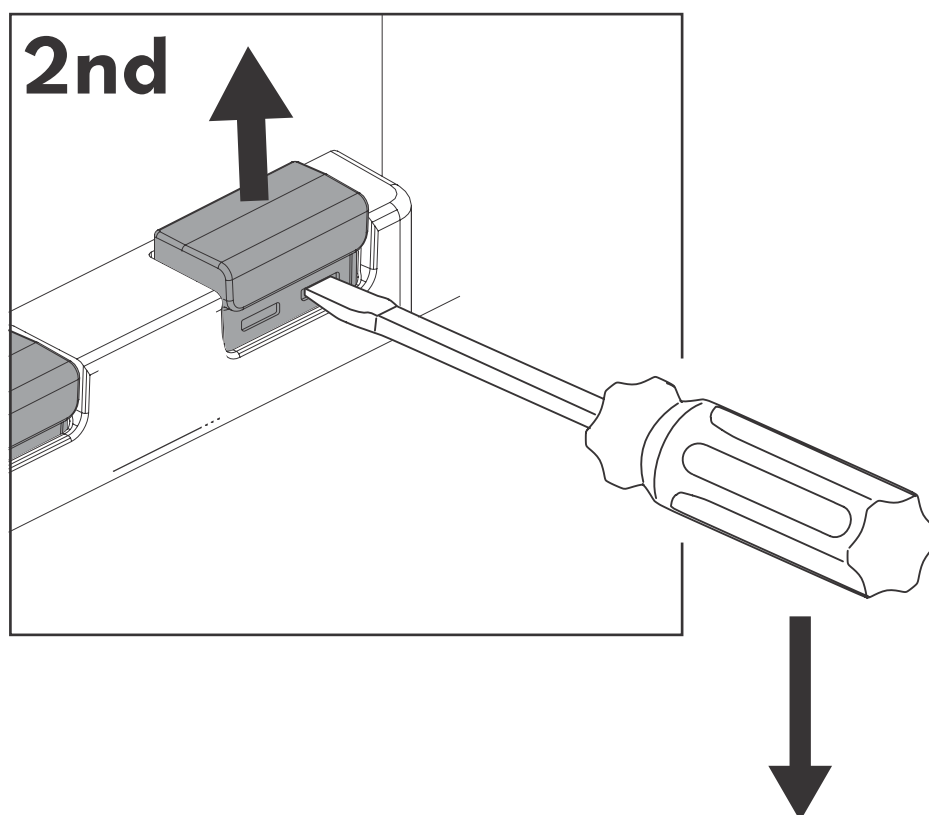
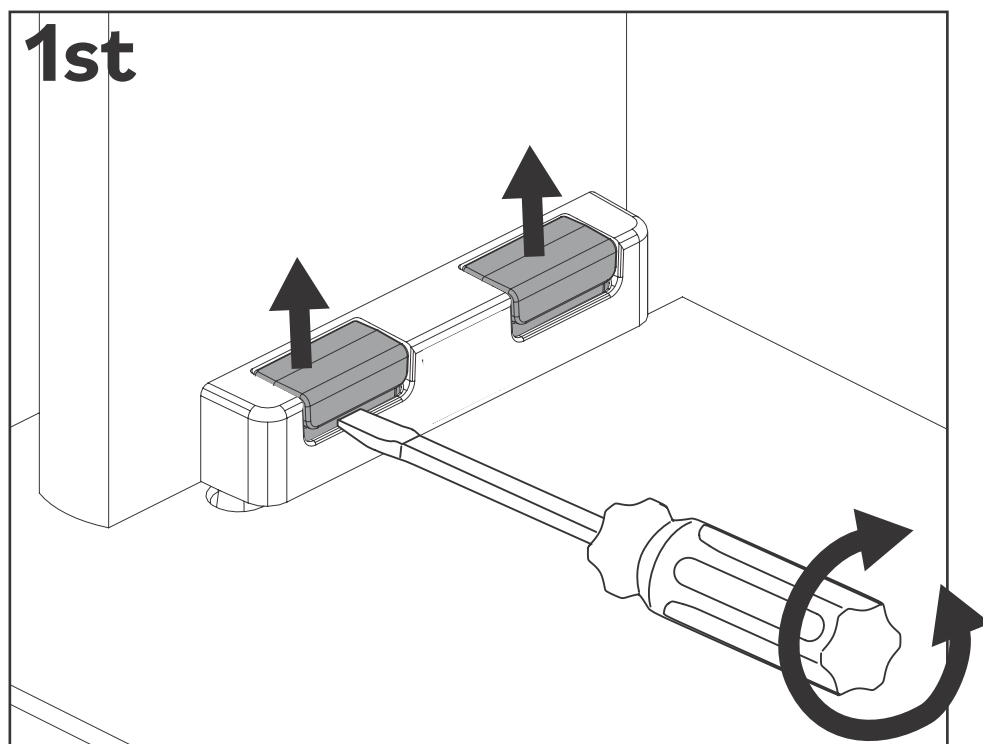

**You did it! Enjoy your new Chest!**

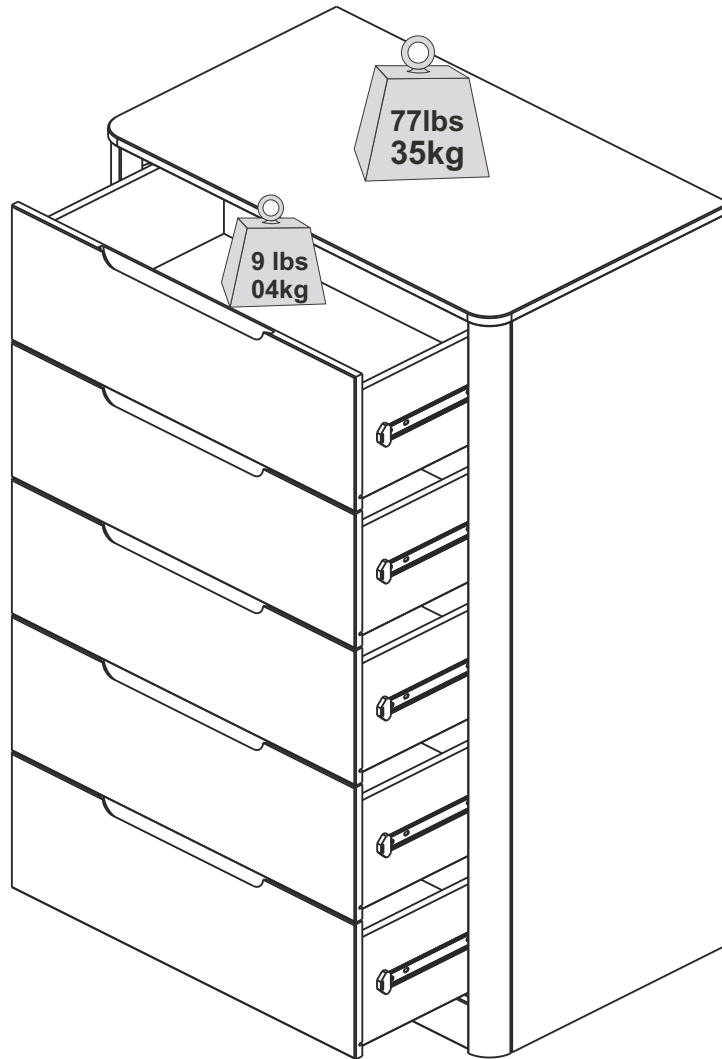

**Congratulations on your new piece of furniture!**

5 Commode à tiroirs  
5 C6m3da con cajones

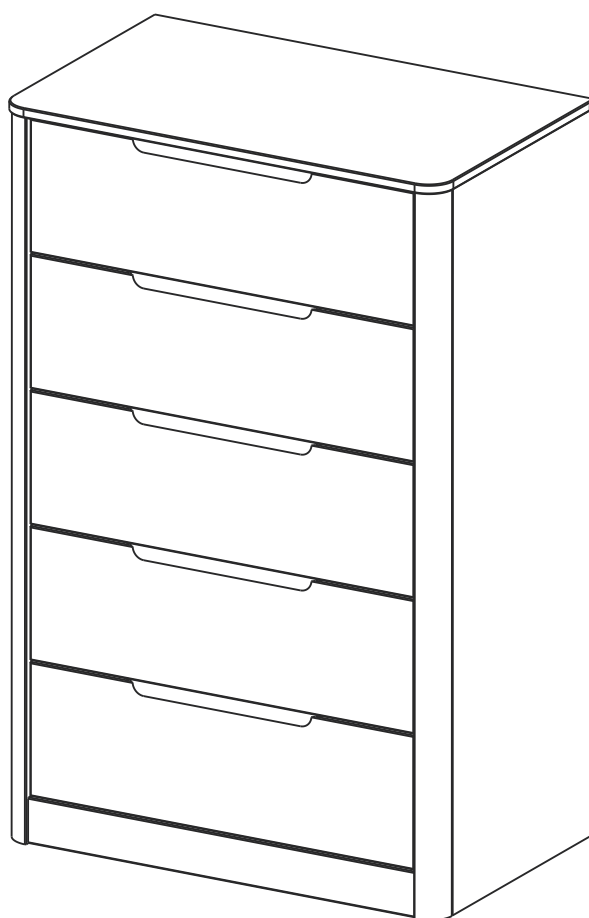

Pour usage r6sidentiel seulement

S6lo para uso residencial

# Il est temps de commencer / Hora de empezar

Prépare un lieu de travail propre et souple pour éviter tout dommage lors de l'assemblage. Tu peux utiliser la boîte et les protections internes comme base. Vérifie également que tu disposes de toutes les pièces et parties avant de te lancer dans l'assemblage.

Prepare un lugar de trabajo limpio y blando para evitar daños durante el montaje. Puede utilizar la caja y las protecciones internas como base. Comprueba también que tiene todas las piezas y partes antes de sumergirse en el montaje.

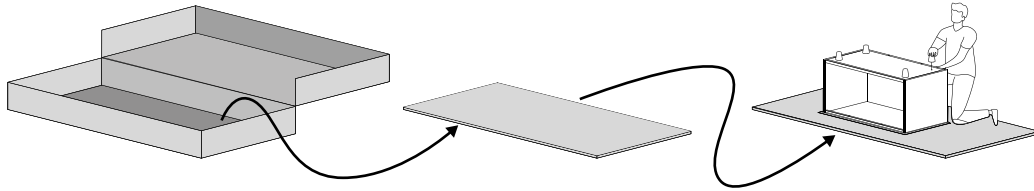

**Temps de montage  
estimé**

**Tiempo estimado de  
montaje**

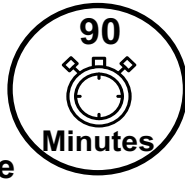

2 Personnes  
2 Personas

**Personnes recommandées  
pour le montage**

Fais-en un effort d'équipe !  
Appelle un ami pour un assemblage  
plus rapide et plus facile.

**Personas recomendadas  
para el montaje**

¡Hágalo en equipo!  
Llame a un amigo para que el  
montaje sea más rápido y sencillo.

## Outils nécessaires

Munis-toi d'un tournevis, tournevis cruciforme et marteau pour réaliser cet assemblage.

## Herramientas requeridas

Tome un destornillador, destornillador Phillips y martillo para conquistar este montaje.

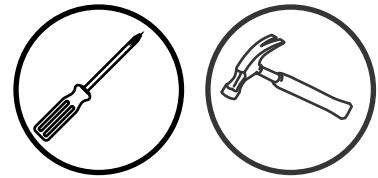

## Utilise les outils électriques avec précaution

Ce meuble est réalisé en Bois Massif et Bois Composite, des matériaux souples. Si tu choisis d'utiliser des outils électriques, règle-les sur le mode le plus lent. Fais attention à toi ! Les outils électriques peuvent provoquer des fissures ou endommager les meubles, mais aussi les autres composants s'ils sont mal utilisés.

## Utilice las herramientas eléctricas con cuidado.

Este mueble está fabricado con madera maciza y madera compuesta, materiales blandos. Si decide utilizar herramientas eléctricas, ajústelas al ajuste más lento. Tenga cuidado. Las herramientas eléctricas pueden causar grietas o daños en el mueble, pero también en los herrajes si se utilizan mal.

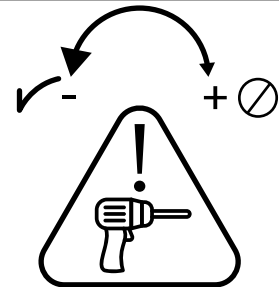

# Liste de pièces / Lista de piezas

Nombre de pièces Número de pieza	Description Descripción	Quantité Cantidad
1	Panneau Droit Panel Derecho	1
2	Panneau Gauche Panel Izquierdo	1
3	Panneau Supérieur Panel Superior	1
4	Barre Avant Travesaño Delantero	1
5	Barre Arrière Travesaño Trasero	1
6	Panneau Arrière Panel Trasero	1
7	Façade du Tiroir Frente del Cajón	5
8	Arrière du Tiroir Trasero del Cajón	5
9	Côté Droit du Tiroir Lado Derecho del Cajón	4
10	Côté Gauche du Tiroir Lado Izquierdo del Cajón	5
11	Fond du Tiroir Inferior del Cajón	5
14	Côté Droit du Tiroir Avertissement Lado Derecho del Cajón Advertencia	1

Le tiroir avec l'ÉTIQUETTE D'AVERTISSEMENT doit être placé comme tiroir le plus haut.

El cajón con ETIQUETA DE ADVERTENCIA, debe colocarse como el cajón más alto.

**▲ WARNING**

Children have died from furniture tipover. To reduce the risk of furniture tipover:

- ALWAYS install anti tip device provided.
- NEVER put a TV on this product.
- NEVER allow children to stand, climb or hang on any drawers, doors, or shelves.
- NEVER open more than one drawer at a time.
- DO NOT defeat or remove the drawer interlock system; it is an important stability and safety system.
- Place heaviest items in the lowest drawers.







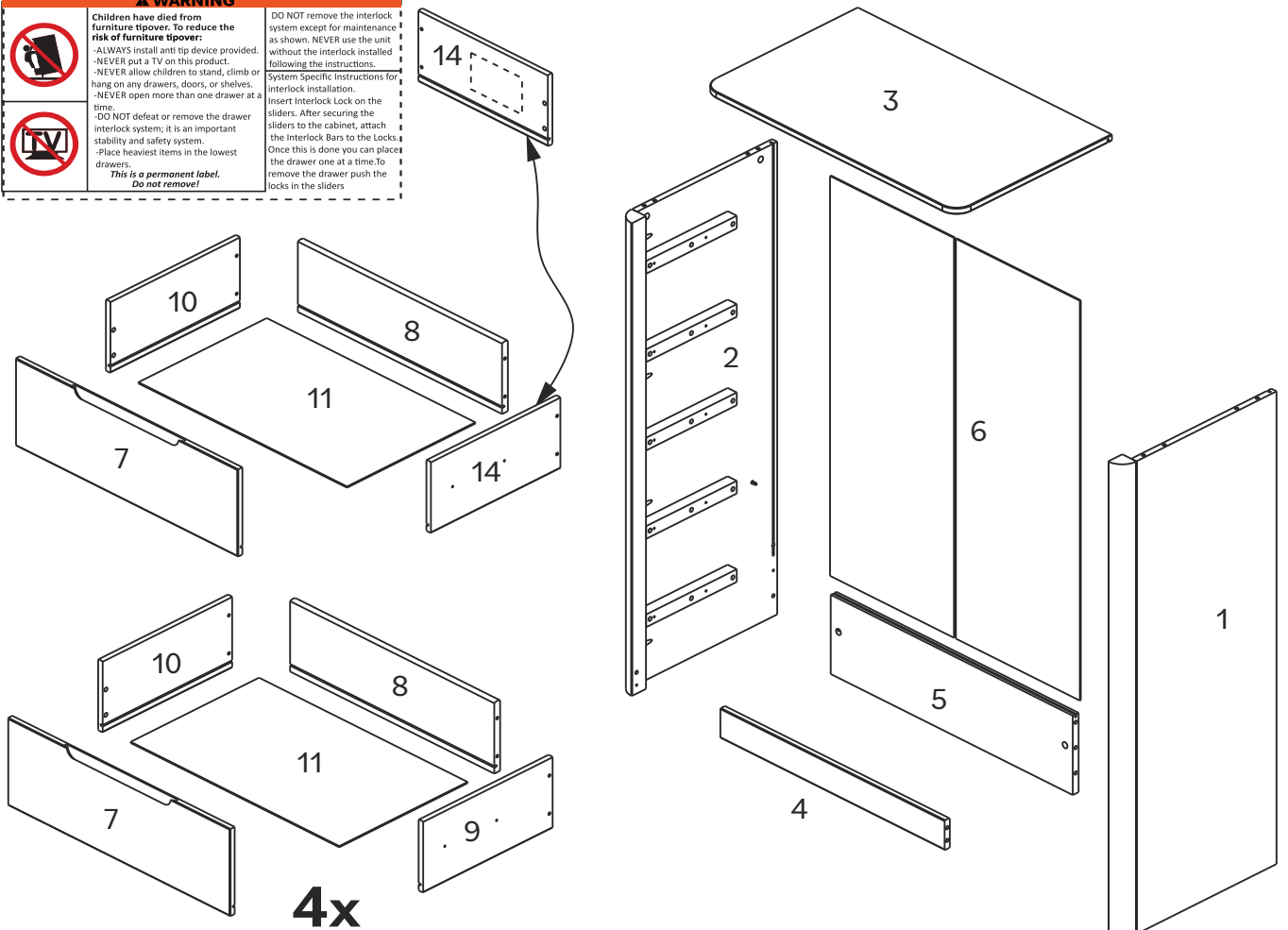









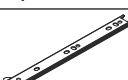

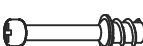
*This is a permanent label. Do not remove!*

DO NOT remove the interlock system except for maintenance as shown. NEVER use the unit without the interlock installed following the instructions.

System Specific Instructions for interlock installation. Insert Interlock Lock on the sliders. After securing the sliders to the cabinet, attach the Interlock Bars to the Locks. Once this is done you can place the drawer one at a time. To remove the drawer push the locks in the sliders.



## Liste de composants / Lista de hardware

Partie Parte	Taille Tamaño	Nom Nombre	Quantité Cantidad
A 		Dovetail Dovetail	10
B 		Dovetail Verrou Dovetail Traba	20
C 		Vis Plastique Tornillo Plástico	20
D 	6x12mm	Vis Tornillo	20
E 		Interlock Serrez Interlock Traba	10
F 	6x20mm	Vis Tornillo	20
G1 	250mm	Glissière Extérieur Corredera Exterior	10
G2 	250mm	Glissière Intérieur Corredera Interior	10
H 	8x30mm	Cheville Espiga	10
I 	6x31mm	Goujon Conector	8
J 	15x11mm	Boitier Traba	8
K 		Interlock Barre Interlock Travesaño	4
L 		Wedge Wedge	12
M 		Rubán Cinta	1
N 	4x16mm	Vis Tornillo	1
O 	6x35mm	Douille Casquillo	1
P 	4x40mm	Vis Tornillo	1
Q 		Rondelle Arandela	2
V 	3,5X14mm	Screw Screw	12

*Les quantités de composants indiquées ci-dessus sont nécessaires pour un assemblage correct.  
Des pièces supplémentaires peuvent être incluses.*

*Las cantidades de tornillería indicadas anteriormente son necesarias para un montaje correcto.  
Se pueden incluir piezas de ferretería adicionales.*

# Introduction pour un assemblage facile du système de tiroirs

**Dis adieu au tracas de l'assemblage !**

Nous comprenons que l'assemblage des tiroirs peut être la partie la plus longue et la plus fastidieuse de l'assemblage de tes nouveaux meubles. C'est pourquoi nous avons développé le système de tiroirs d'assemblage facile - pour rendre le processus plus facile !

**Dovetail Verrouillage Traba**

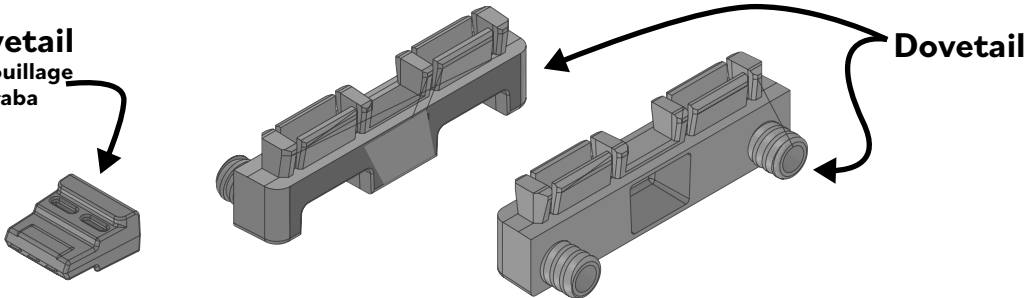

## Pourquoi tu vas adorer notre système de tiroirs d'assemblage facile :

**Rapide et facile :** notre nouveau système de tiroir réduit considérablement le temps d'assemblage. Fais-le vite !

**Effort minimal requis :** Conçu pour être extrêmement simple, tu n'auras besoin que de peu ou pas d'outils pour effectuer le travail.

**Construit pour durer :** Solide et résistant, notre système garantit que tes tiroirs restent solides et fiables.

## Préparons le scénario pour l'assemblage :

### Step 1: Prépare-toi -

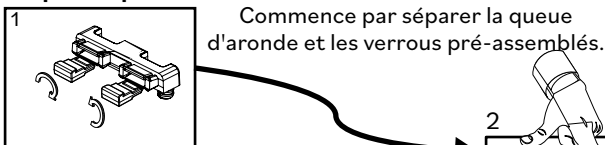

Commence par séparer la queue d'aronde et les verrous pré-assemblés.

**Step 2: Jonction -**  
Combine la queue d'aronde avec les côtés du tiroir comme indiqué sur l'illustration.

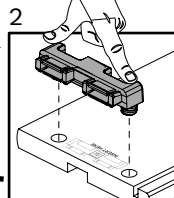

**Step 3: Glisse dans la rainure -**  
Fais glisser la queue d'aronde dans les rainures de la face avant des tiroirs.

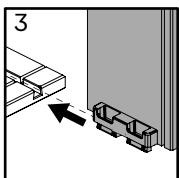

**Step 4: Verrouillage -**  
Après avoir installé le fond du tiroir, verrouille la queue d'aronde à l'aide des loquets à queue d'aronde

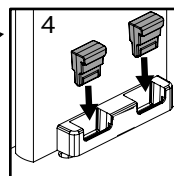

**Attention :** Lors des prochaines étapes, tu trouveras plus de détails pour t'aider durant l'assemblage.

# Introducción al Sistema de Fácil Montaje de Cajones

**¡Despídete de las complicaciones del montaje!**

Entendemos que ensamblar cajones puede ser la parte más lenta y tediosa de ensamblar tus muebles nuevos. Es por eso que desarrollamos el Sistema de Cajones de Montaje Fácil, ¡para facilitar el proceso!

## Por qué te encantará nuestro sistema de cajones fácil de montar:

**Rápido y fácil :** nuestros nuevos herrajes para cajones reducen significativamente el tiempo de montaje. ¡Hazlo rápido!

**Mínimo esfuerzo requerido :** Diseñado para ser muy simple, necesitarás pocas o ninguna herramienta para hacer el trabajo.

**Fabricado para durar :** Fuerte y resistente, nuestro sistema garantiza que tus cajones permanezcan sólidos y confiables.

## Preparamos el espacio para el montaje:

### Step 1: ¡Prepárate! -

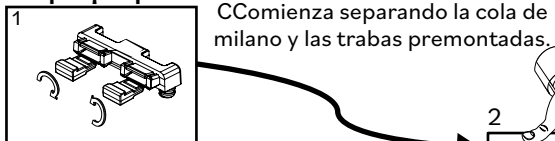

Comienza separando la cola de milano y las trabas premontadas.

**Step 2: Unión -**  
Combina la cola de milano con los lados del cajón, como se muestra en la ilustración.

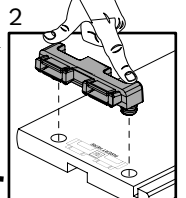

**Step 3: Desliza en la ranura -**  
Desliza la cola de milano en las ranuras de los frentes de los cajones.

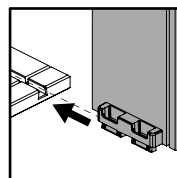

**Step 4: Traba -**  
Después de colocar la parte inferior del cajón, bloquea la cola de milano usando las trabas de cola de milano.

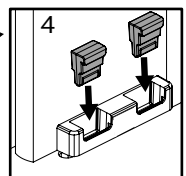

**Atención :** En los próximos pasos, hay más detalles para ayudarte con el montaje.

# Étape / Paso 1

(FR)

Préparez les Dovetails (A) en retirant les Dovetail verrous (B) des Dovetails (A).

(ES)

Prepare las Dovetails (A) quitando las Trabas del Dovetail (B) de los Dovetails (A).

1st

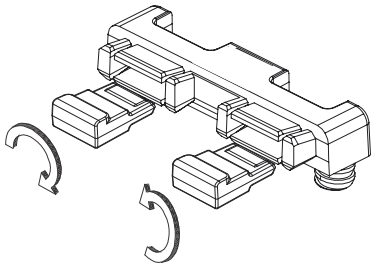

2nd

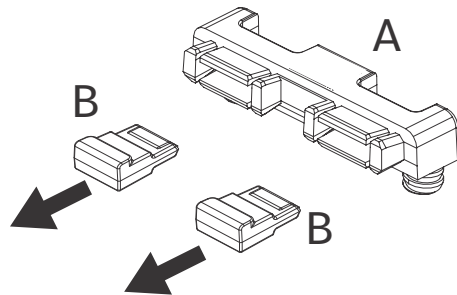

# Étape / Paso 2

(FR)

Enclenchez les Dovetails (A) sur les côtés droit (9 et 14) et gauche (10) du tiroir. Appuyez sur les Dovetails jusqu'à ce qu'elles soient bien fixées. Utilisez un marteau si nécessaire.

(ES)

Coloque los Dovetails (A) en su lugar en los laterales derecho (9 y 14) y izquierdo del cajón (10). Presione los Dovetails hasta que queden completamente fijadas. Use un martillo si es necesario.

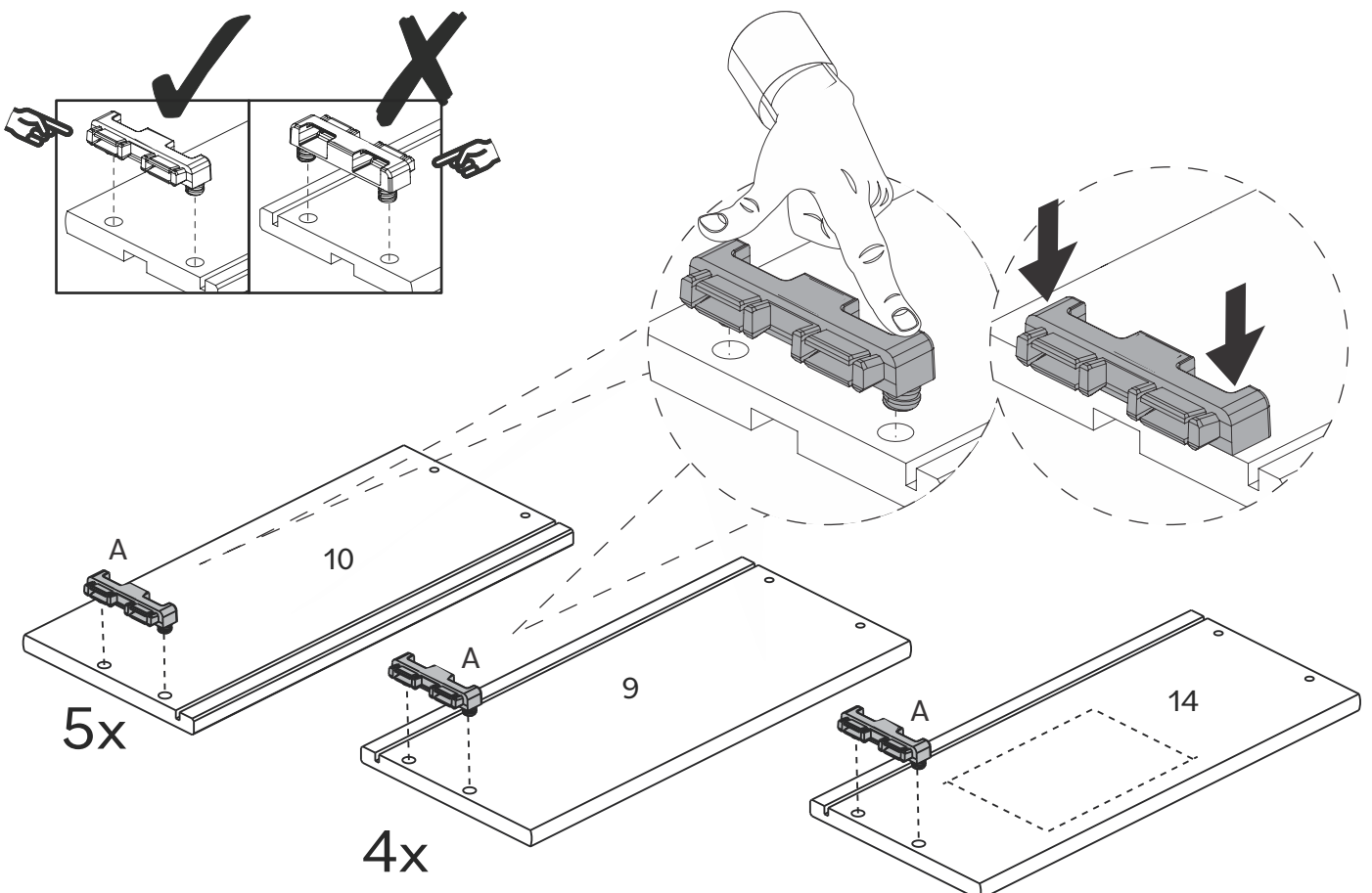

# Étape / Paso 3

(FR)

Faites glisser la dovetail (A) du côté droit (9/14) et du côté gauche de tiroir (10) dans les rainures de la façade du tiroir (8 et 13).

(ES)

Deslice la Dovetail (A) del lado derecho (9/14) y del lado izquierdo del cajón (10) en las ranuras del frente del cajón (8 y 13).

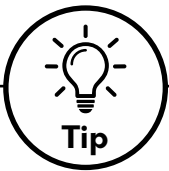
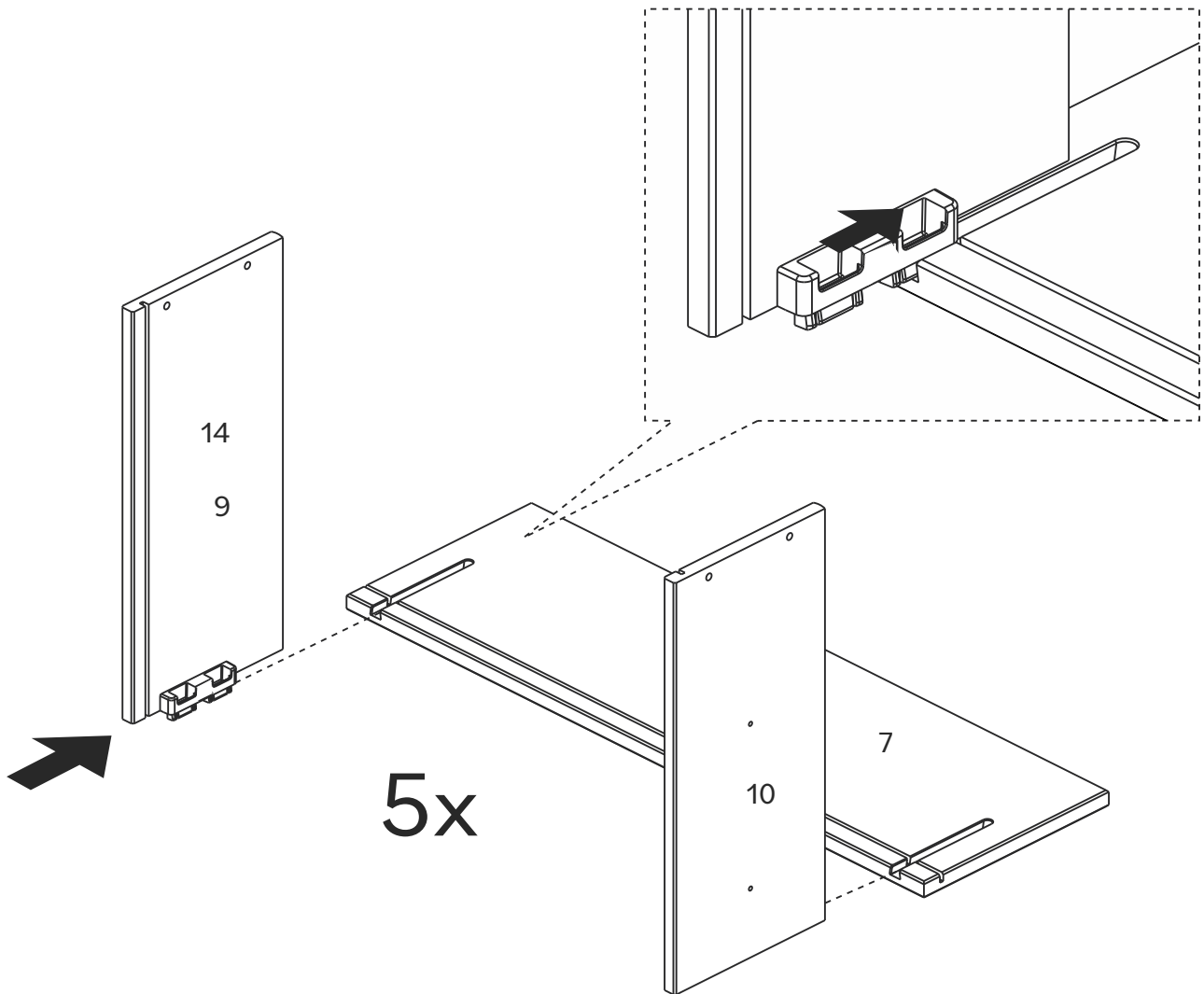

## Tip

Pour que ton produit conserve son meilleur aspect et sans rayures, essaie de le monter sur une surface souple telle qu'un tapis ou une couverture. Cela permet d'éviter les rayures accidentelles et de garder tes meubles en bon état !

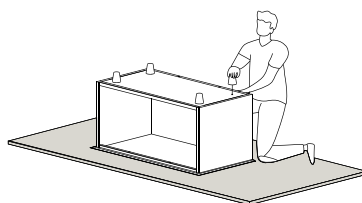

Para mantener su producto con el mejor aspecto y sin arañazos, pruebe a montarlo sobre una superficie blanda, como una alfombra o una manta. Así evitará arañazos accidentales y mantendrá sus muebles en perfecto estado.

# Étape / Paso 4



(FR)

Faites glisser le fond du tiroir (12) dans les rainures du côté droit (9/14), du côté gauche de tiroir (10) et de la façade du tiroir (8/13).

(ES)

Deslice la parte inferior del cajón (12) en las ranuras del lado derecho (9/14), el côté izquierdo del cajón (10) y el frente del cajón (8/13).

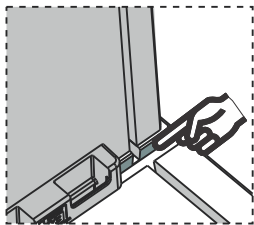

Alignez les rainures sur les côtés et le devant du tiroir pour recevoir le fond du tiroir

Alinee las ranuras en los lados y el frente del cajón para recibir la parte inferior del cajón.

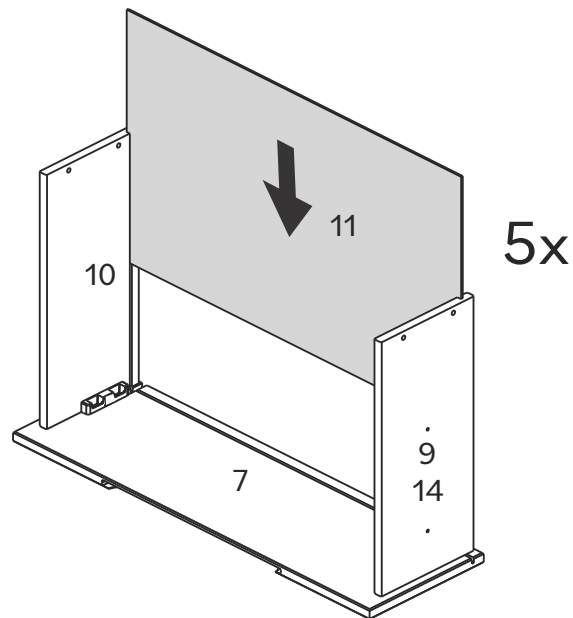

# Étape / Paso 5



(FR)

Pour fixer les côtés du tiroir, insérez les Dovetaills verrous (B) dans les Dovetaills (A). Utilisez un marteau si nécessaire.

(ES)

Para asegurar los laterales del cajón, inserte las Trabas del Dovetail (B) en las dovetails (A). Use un martillo si es necesario.

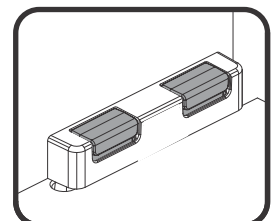
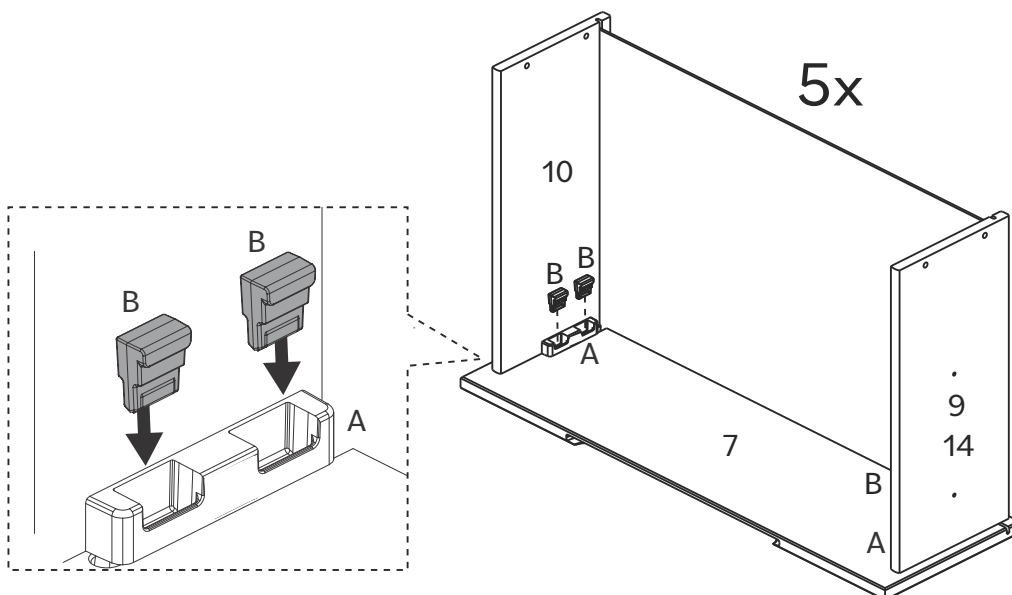

# Étape / Paso 6



(FR)

Fixez le fond du tiroir (12) au arrière du tiroir (11) et fixez-le à l'aide de la vis en plastique (C). Vous pouvez l'insérer avec vos mains ou à l'aide d'un marteau..

(ES)

Coloque la parte inferior del cajón (12) en la parte trasera del cajón (11) y asegúrelo con el tornillo de plástico (C), puede insertarlo con las manos o con un martillo.

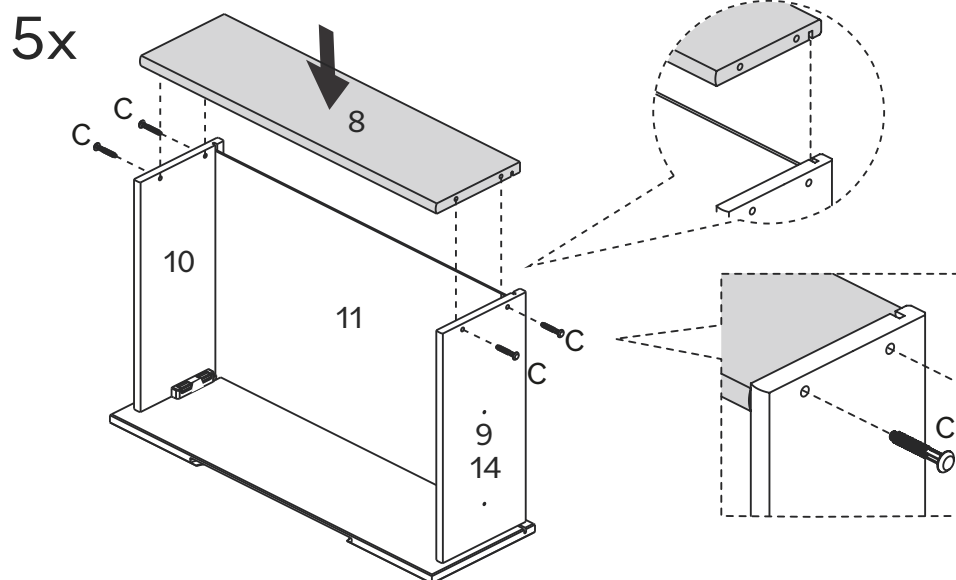

# Étape / Paso 7

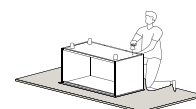

(FR)

Fixez les glissières intérieures (G2) sur les côtés droits du tiroir (9 et 14) et les côtés gauches du tiroir (10) à l'aide de la vis (D) et d'un tournevis cruciforme.

(ES)

Coloque las correderas internas (G2) en los lados del cajón derecho (9 y 14) y en los lados del cajón izquierdo (10) usando el tornillo (D) y un destornillador Phillips.

Séparer les parties G1 et G2 en appuyant sur le verrou.

Separare las piezas G1 y G2 presionando el bloqueo

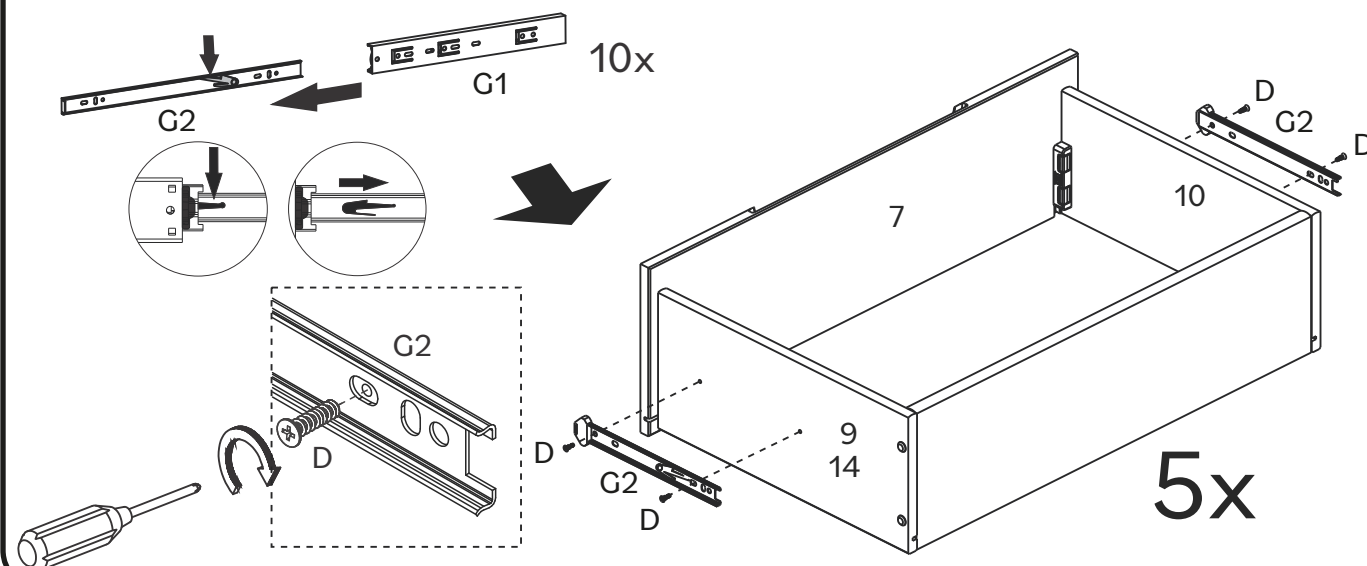

# Étape / Paso 8



(FR)

Tiroirs assemblés, commençons la construction de la commode ! Insérez les chevilles en bois (H) dans le panneau droit (1), le panneau gauche (2), le barre arrière (5) et le barre avant (4).

(ES)

Con los cajones armados, ¡comencemos con la cómoda! Inserta las espigas de madera (H) en el panel derecho (1), el panel izquierdo (2), el travesaño trasero (5) y el travesaño delantero (4).

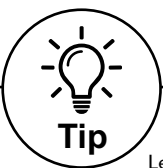
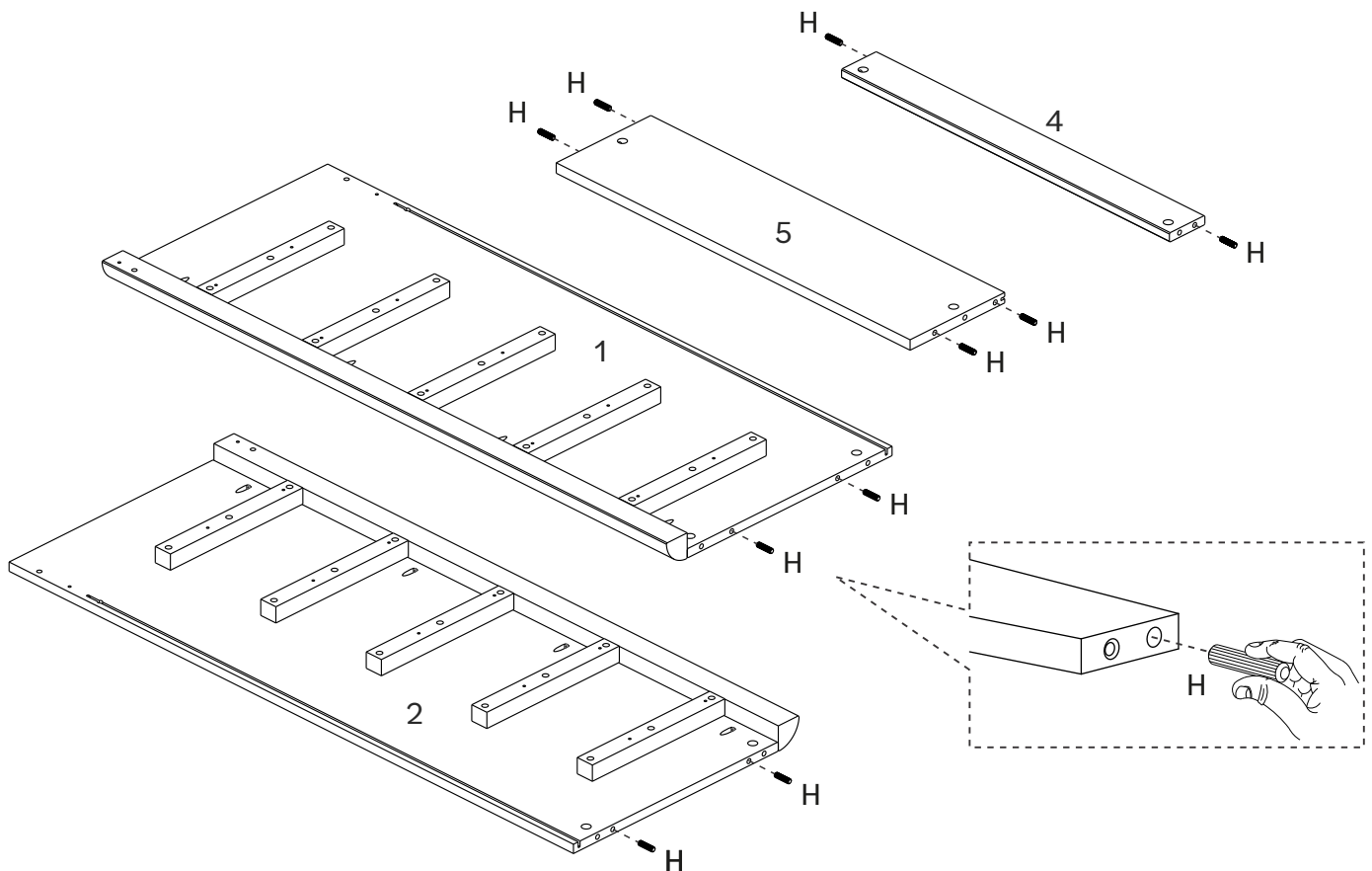

Tip

## Cheville en bois

Les chevilles sont essentielles lors de l'assemblage de meubles pour créer des connexions solides et précises. Elles garantissent l'intégrité structurelle, empêchent les déplacements et simplifient l'alignement, ce qui permet d'obtenir des meubles plus résistants et plus durables. suis ces étapes :

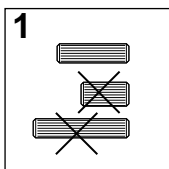

- 1: Sélectionne la taille de cheville appropriée en fonction de l'étape.
- 1: Seleccione el tamaño de espiga adecuado según el paso.

## Espiga de madera

Las espigas son esenciales en el montaje de muebles para crear uniones fuertes y precisas. Garantizan la integridad estructural, evitan el desplazamiento y simplifican la alineación, lo que se traduce en muebles más resistentes y duraderos.

Sigue estos pasos:

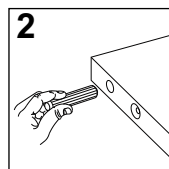

- 2: Insère dans le trou indiqué et appuie fermement pour assurer un positionnement correct.
- 2: Insértela en el orificio indicado y presione firmemente para asegurar su correcta colocación.

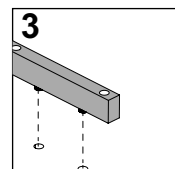
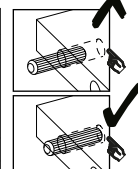

- 3: Aligne la cheville avec la pièce correspondante et enfonce-la jusqu'à ce qu'elle soit ferme.
- 3: Alinee el pasador con la pieza correspondiente y presiónelo hasta que encaje.

# Étape / Paso 9



(FR)

Fixez les goujons (I) au panneau droit (1), au panneau gauche (2) et au panneau supérieur (3) à l'aide d'un tournevis cruciforme.

(ES)

Coloque los conectores (I) en el panel derecho (1), el panel izquierdo (2) y el panel superior (3) usando un destornillador Phillips.

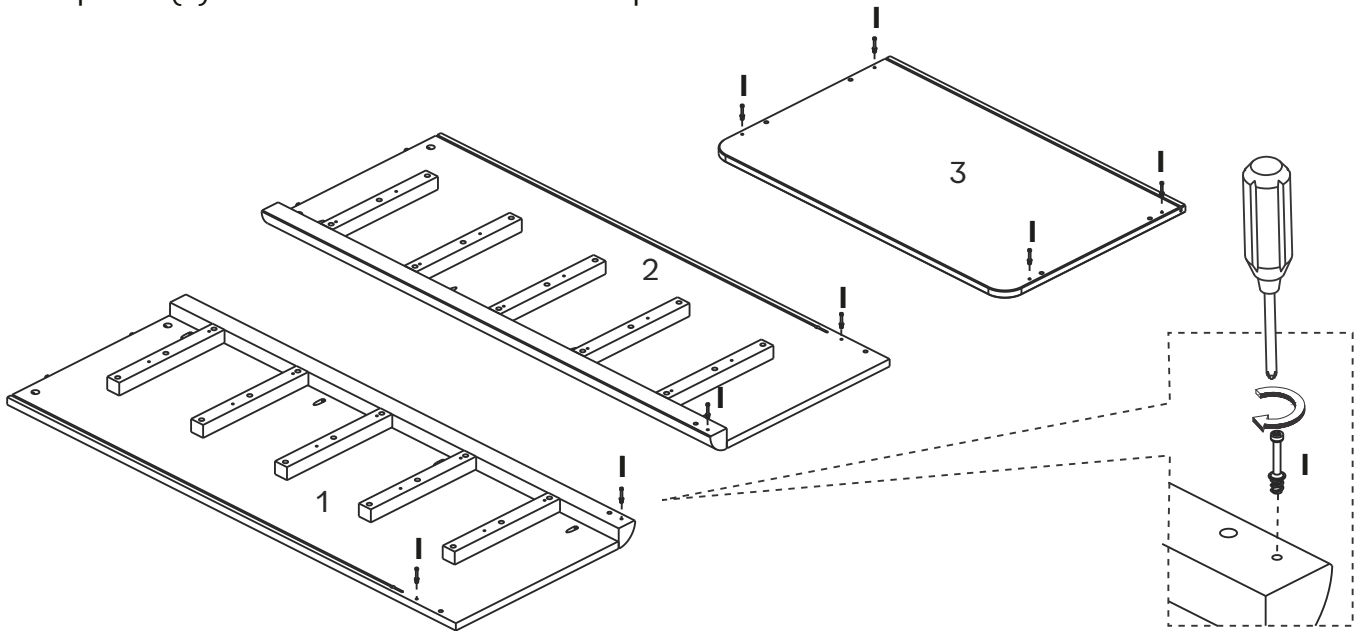

# Étape / Paso 10

(FR)

Prenez le coulisseau extérieur (G1) et insérez le Interlock Serrez (E) conformément au schéma ci-dessous.

(ES)

Tome la corredera exterior (G1) e inserte el Interlock Traba (E) según el diagrama a continuación.

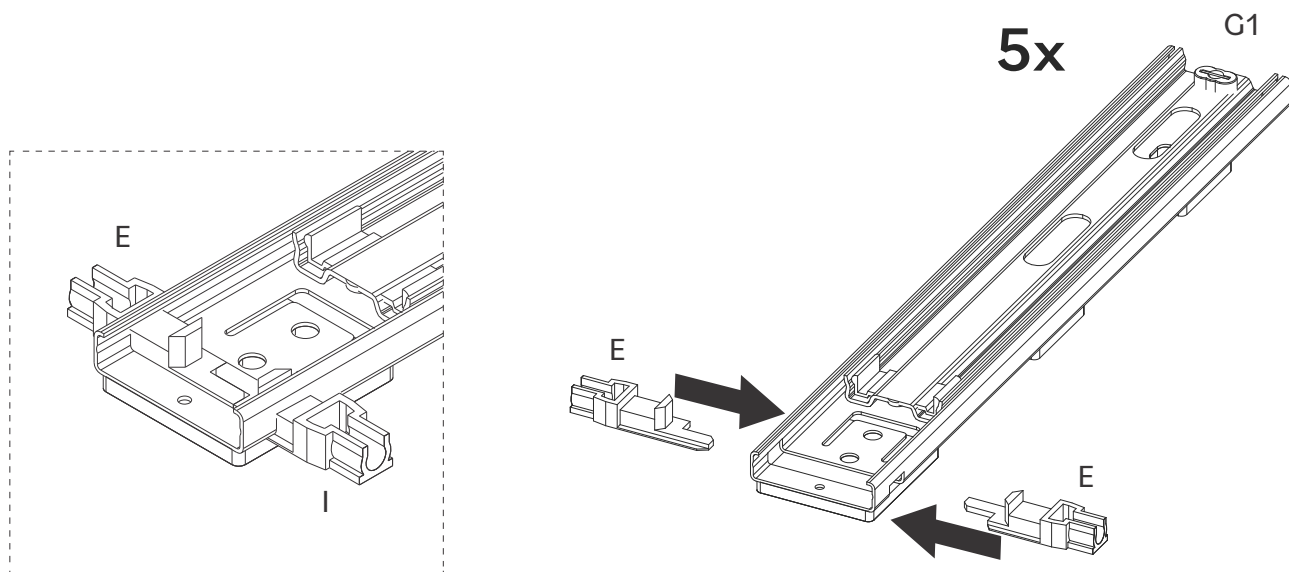

# Étape / Paso 11



(FR)

Fixez la glissière extérieure (G1) aux panneaux droit (1) et gauche (2) à l'aide de la vis (F) et d'un tournevis cruciforme.

(ES)

Fije el deslizador exterior (G1) a los paneles derecho (1) e izquierdo (2) con el tornillo (F) y un destornillador Phillips.

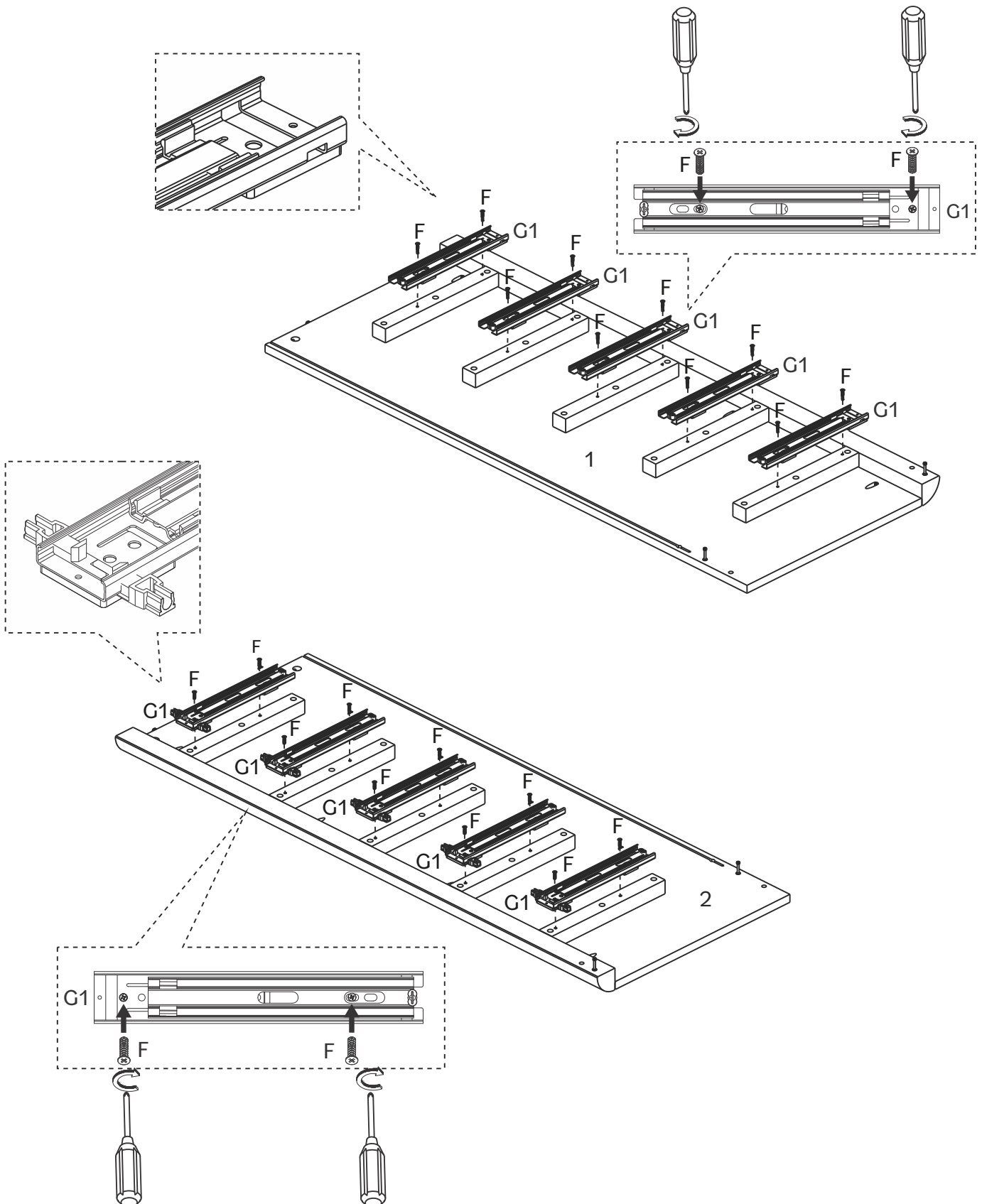

# Étape / Paso 12



(FR)

Fixez le barre avant (4) et le barre arrière (5) au panneau droit (1) à l'aide des boitier (J) et d'un tournevis cruciforme.

(ES)

Conecte el travesaño delantero (4) y el travesaño trasero (5) al panel derecho (1) usando traba (J) y un destornillador Phillips.

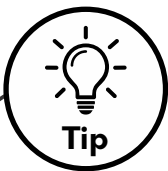
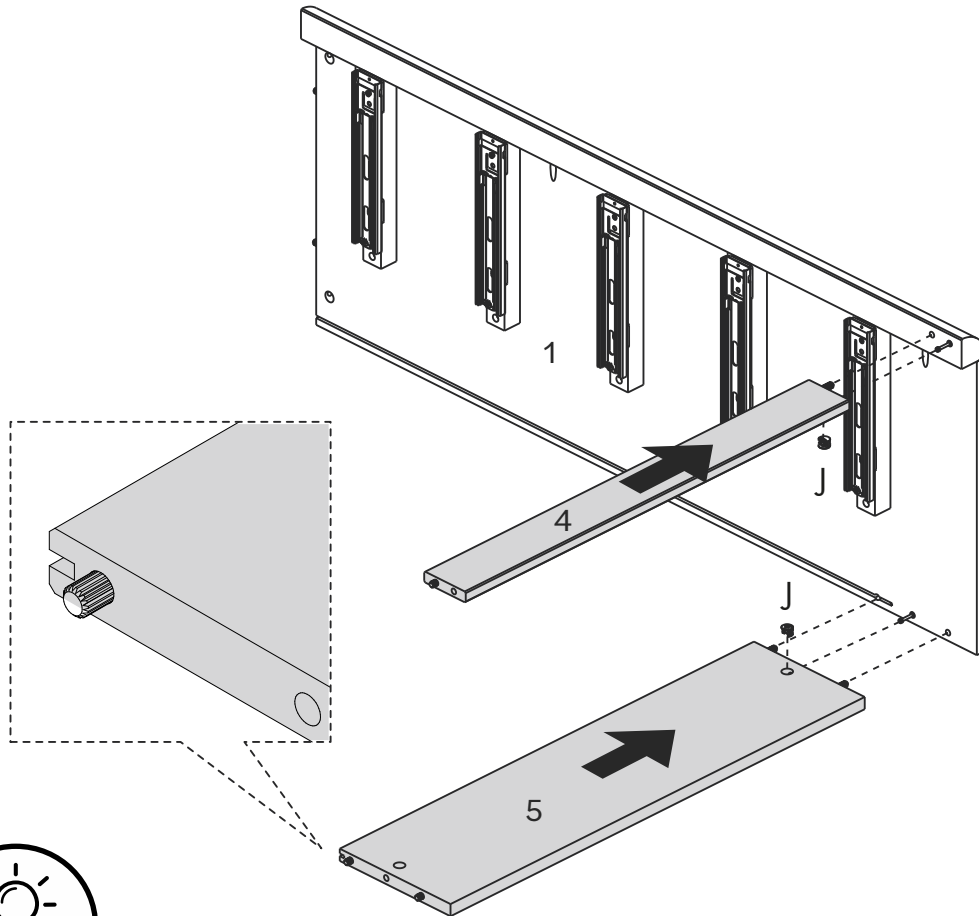

Tip

## Goujon de Assemblage

Goujon de Assemblage permet de joindre deux pièces en toute sécurité. Suis ces étapes simples.

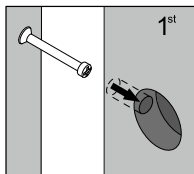

1: Insère le Goujon dans les orifices du côté plat. Ne serre pas trop!

1: Coloca el Conector en los orificios del lado plano. ¡No aprietes demasiado!

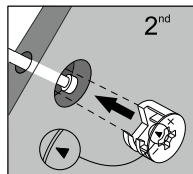

2: Joins les pièces en bois. Les Goujons entrent dans les orifices qui ont des trous sur les côtés, tu dois pouvoir voir les Goujons à travers ceux-ci. Après avoir installé les pièces, insère le Boitiers dans les orifices latéraux

2: Una las piezas de madera. Los Conectores entran en las piezas que tienen orificios en los lados, por lo que deberías poder ver los Conectores a través de ellos. Después de encajar las piezas, inserta la traba en los orificios laterales.

## Conector

Los Conector ayudan a unir de forma segura dos piezas. Sigue estas fáciles etapas.

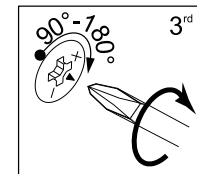

3: Sur la partie arrière du boitier, il aura la forme d'un « C ». Insère le boitier de manière à ce que l'ouverture « C » s'emboîte à la goujon. Serre-la avec le tournevis.  
3: La parte posterior de la traba tendrá la forma de "C". Inserta el tambor de modo que la abertura de la "C" encaje en el Conector. Apriétalo con un destornillador.

# Étape / Paso 13

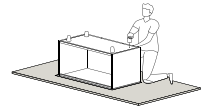

(FR)

Joignez le panneau gauche (2) à l'aide des boîtiers (J) et d'un tournevis cruciforme.

(ES)

Una el panel izquierdo (2) usando traba (J) y un destornillador Phillips.

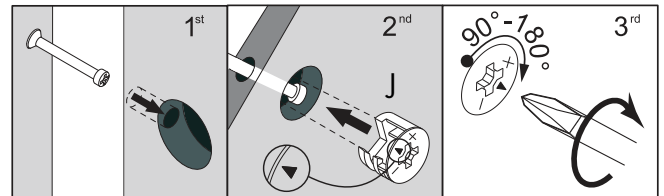
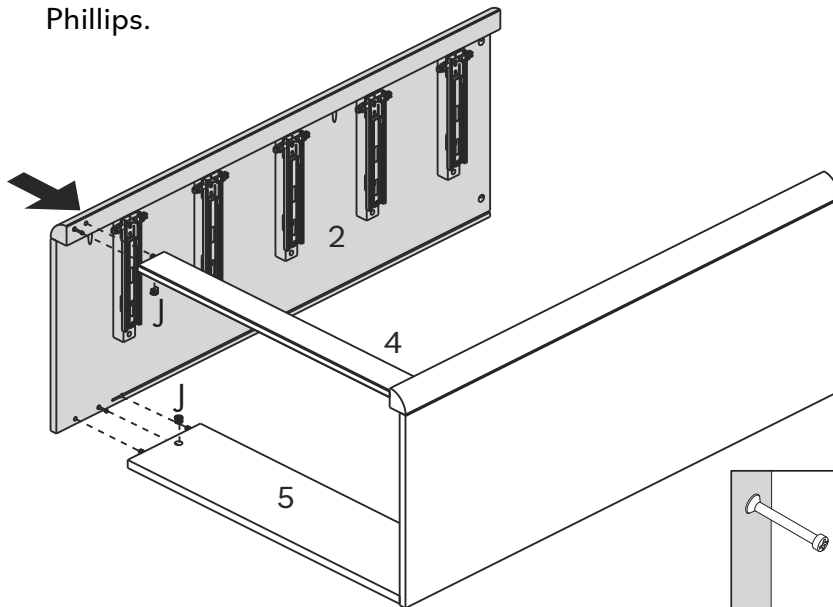

# Étape / Paso 14

(FR)

Faites glisser le panneau arrière (6) sur les rainures des panneaux droit et gauche (1 et 2) et insérez-le dans le barreau arrière (5).

(ES)

Deslice el panel trasero (6) en las ranuras de los paneles derecho e izquierdo (1 y 2) y ajústelo en el travesaño trasero (5).

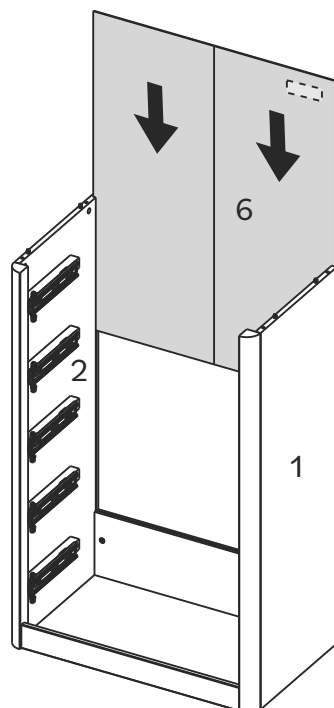

L'étiquette de traçabilité doit être orientée vers l'extérieur  
La etiqueta de trazabilidad debe estar orientada hacia afuera

Nom et adresse du fournisseur et date de production.  
Nombre y dirección del proveedor y fecha de producción.

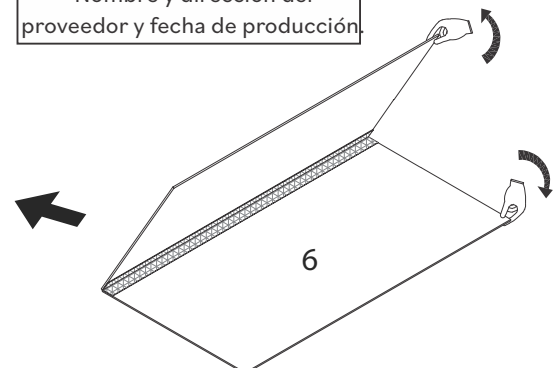

# Étape / Paso 15

(FR)

Fixez le panneau supérieur (3) à l'aide des boîtiers (J) et d'un tournevis cruciforme.

(ES)

Asegure el panel superior (3) usando traba (J) y un destornillador Phillips.

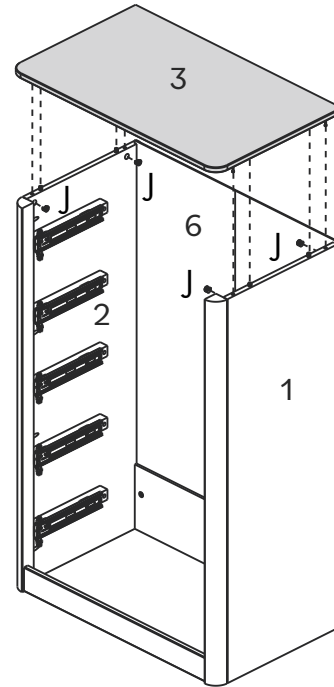
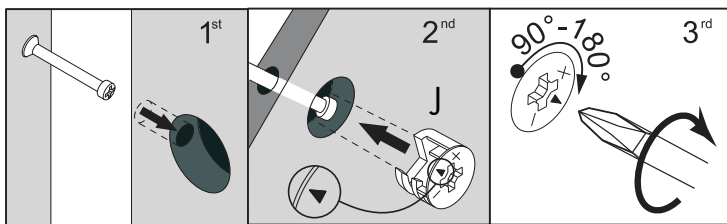

# Étape / Paso 16

(FR)

Fixez la barre de Interlock Barre (K) dans les Interlock Serrez (E).

(ES)

Coloque la Interlock Barre (K) en las Interlock Serrez (E).

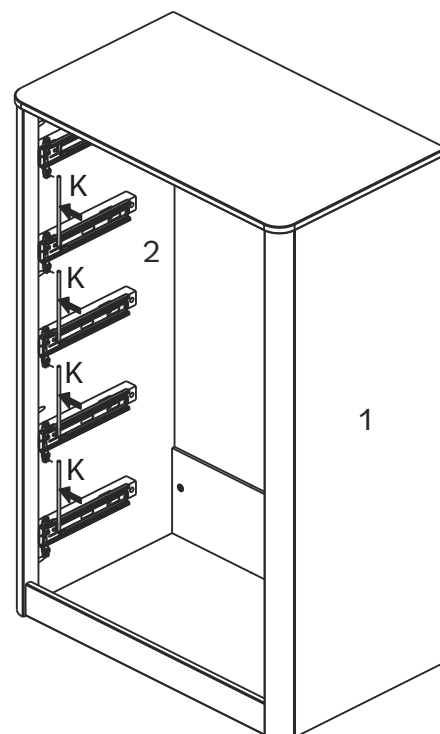
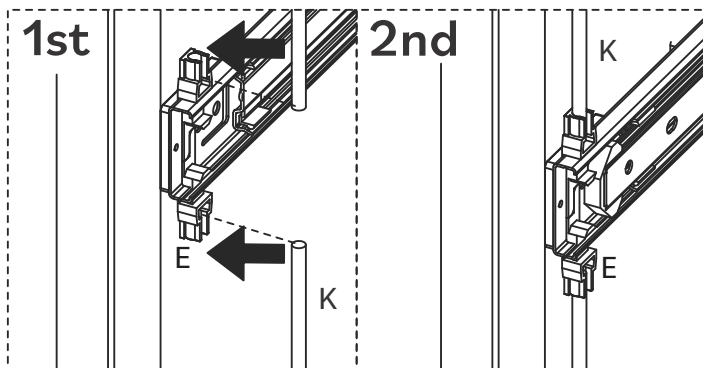

# Étape / Paso 17

(FR)

Fixez le Panneau Arrière (6) en insérant la Cale (L) et la vis (R) entre le panneau et les rainures. Utilisez un tournevis Phillips.

(ES)

Asegure el Panel Trasero (6) colocando la Cuña (L) y el tornillo (R) entre el panel y las ranuras. Use un destornillador

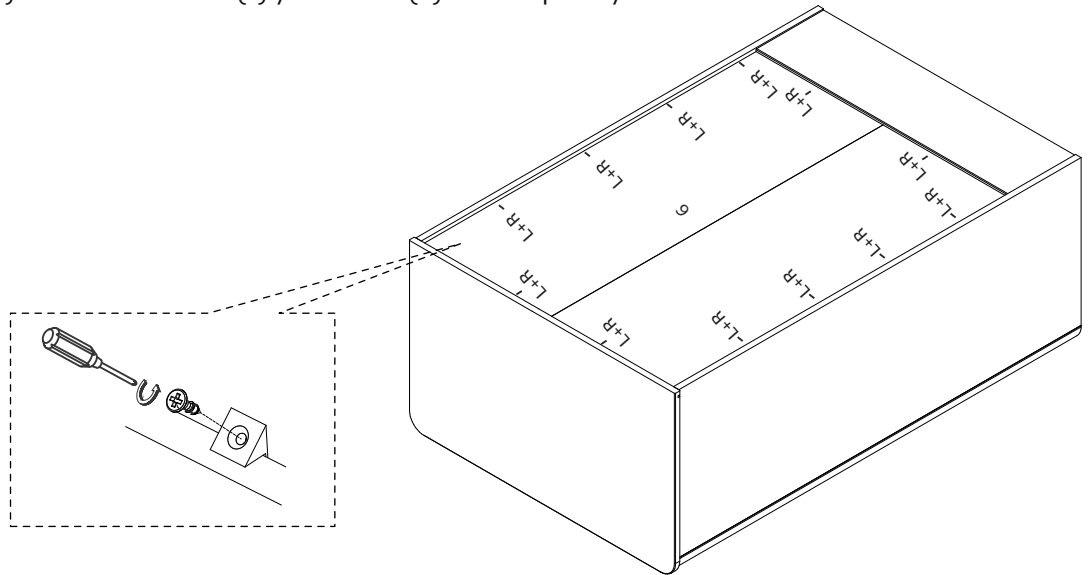

# Étape / Paso 18

(FR) Placez les tiroirs un par un à l'aide du curseur, veillez à les positionner correctement en alignant le curseur extérieur et intérieur.

(ES) Coloque los cajones uno a uno usando la corredera, preste atención a posicionarlos correctamente alineando las correderas externo e interno.

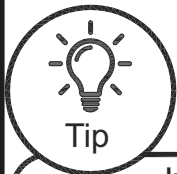

Tip

### Insérez correctement le tiroir de votre armoire

Alignez les glissières extérieure et intérieure et poussez légèrement le tiroir à l'intérieur du meuble. Une fois la connexion établie, poussez le tiroir jusqu'à ce qu'il soit bien en place. Le glissement peut être délicat au début, mais il s'améliore une fois la connexion établie.

### Inserte el cajón de su gabinete correctamente

Alinee las correderas exterior e interior y empuje el cajón ligeramente dentro de la unidad. Una vez que sienta la conexión, empujelo hasta que encaje completamente. Puede que al principio no se deslice con suavidad, pero mejora una vez que esté completamente conectado.

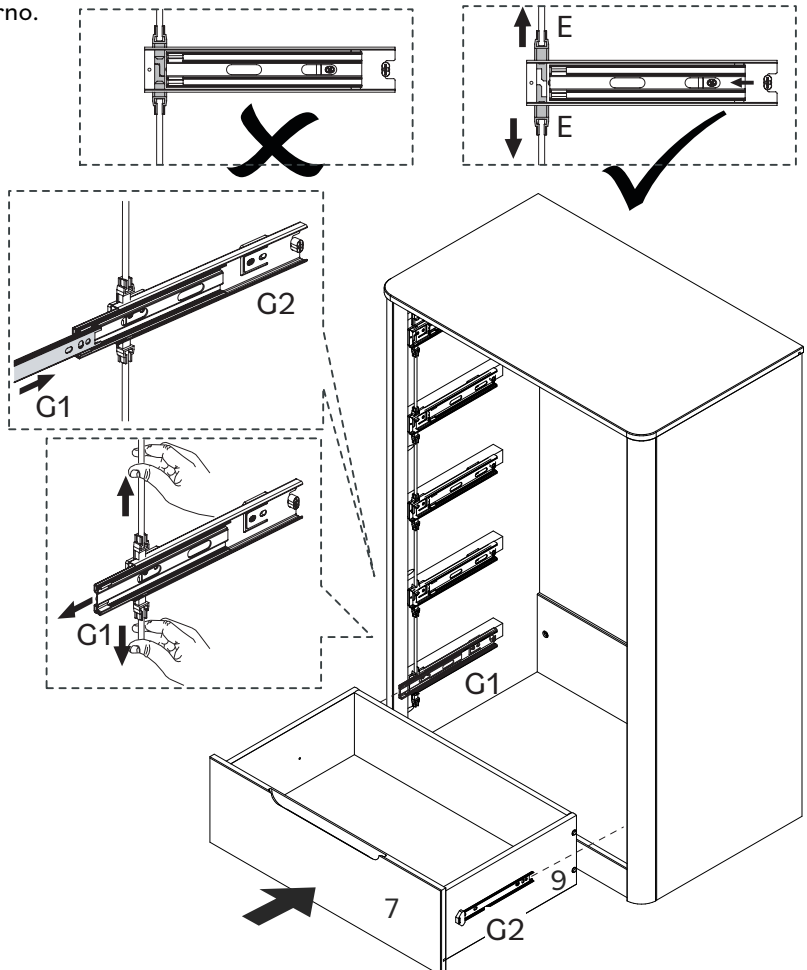
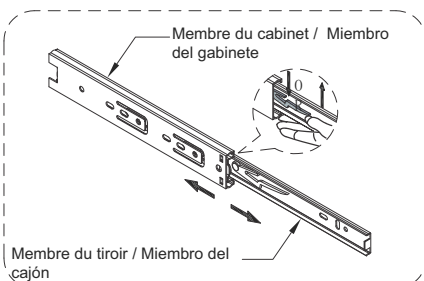

# Étape / Paso 19

(FR)

Placez les tiroirs un par un à l'aide du curseur, veillez à les positionner correctement en alignant le curseur extérieur et intérieur.

(ES)

Coloque los cajones uno a uno usando la corredera, preste atención a posicionarlos correctamente alineando las correderas externo e interno.

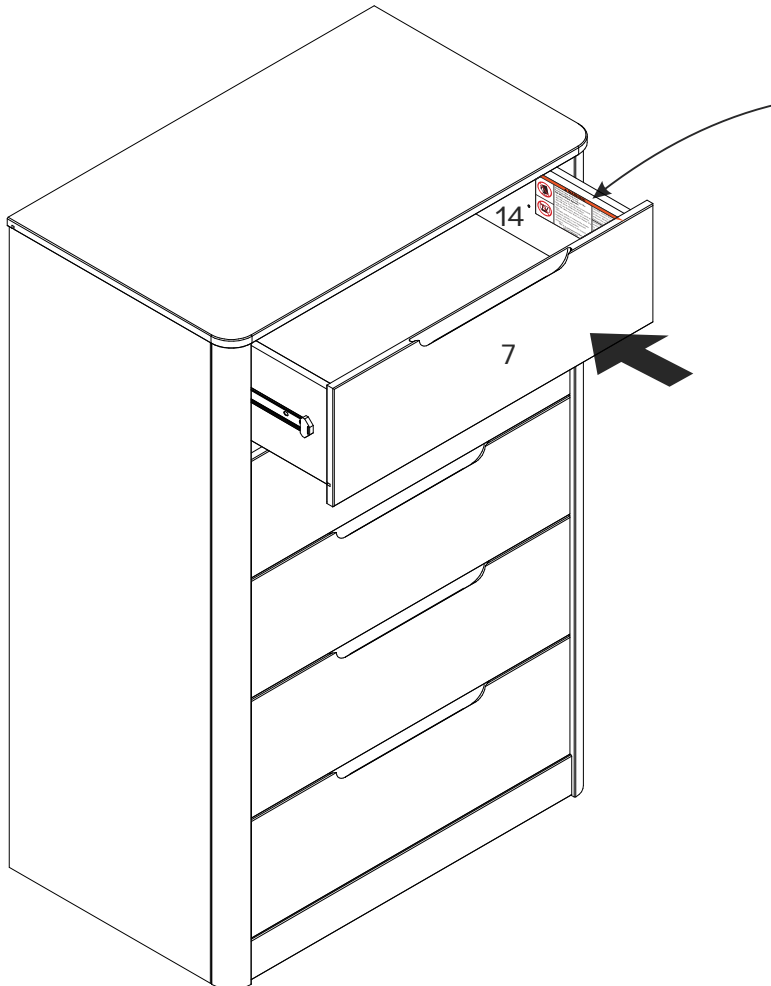

⚠ WARNING	
	<p>Children have died from furniture tipover. To reduce the risk of furniture tipover:</p> <ul style="list-style-type: none"> <li>-ALWAYS install anti tip device provided.</li> <li>-NEVER put a TV on this product.</li> <li>-NEVER allow children to stand, climb or hang on any drawers, doors, or shelves.</li> <li>-NEVER open more than one drawer at a time.</li> <li>-DO NOT defeat or remove the drawer interlock system; it is an important stability and safety system.</li> <li>-Place heaviest items in the lowest drawers.</li> </ul> <p><i>This is a permanent label. Do not remove!</i></p>
	<p>DO NOT remove the interlock system except for maintenance as shown. NEVER use the unit without the interlock installed following the instructions.</p> <p>System Specific Instructions for interlock installation. Insert Interlock Lock on the sliders. After securing the sliders to the cabinet, attach the Interlock Bars to the Locks. Once this is done you can place the drawer one at a time. To remove the drawer push the locks in the sliders</p>

Le côté du tiroir avec l'étiquette d'avertissement doit être positionné comme le tiroir le plus haut

El lateral del cajón con etiqueta de advertencia debe colocarse como el cajón más alto.

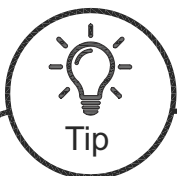
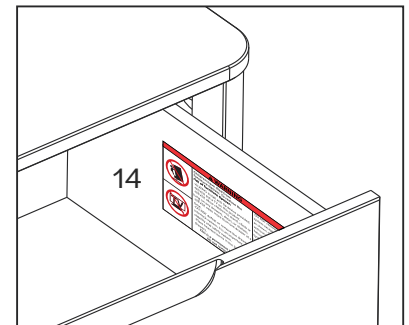

## Retrait du tiroir

Il y a un levier blanc dans chaque glissière.  
 Pour retirer les tiroirs, tirez le tiroir jusqu'à ce que vous voyiez le levier. Poussez un levier vers le haut et l'autre vers le bas, tout en poussant, tirez le tiroir vers l'extérieur.

## Extracción del cajón

Hay una palanca blanca en cada riel. Para quitar los cajones, tire del cajón hasta que vea la palanca. Empuje una palanca hacia arriba y la otra hacia abajo, y mientras empuja, saque el cajón.

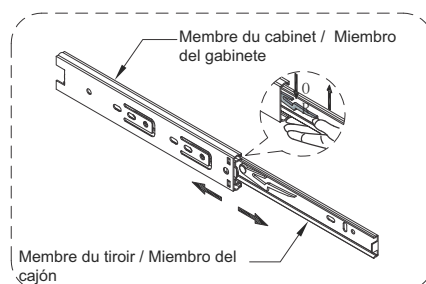

# Étape / Paso 20

(FR)

Pour terminer, fixez le kit anti-basculement. Fixez l'ruban (M) au panneau supérieur (3) à l'aide d'une rondelle (Q), d'une vis (N) et d'un tournevis cruciforme en suivant les instructions du schéma ci-dessous.

(ES)

Para finalizar, instale el kit antivuelco. Fije el cinta (M) al panel superior (3) con la arandela (Q), el tornillo (N) y un destornillador Phillips, siguiendo las instrucciones del diagrama a continuación.

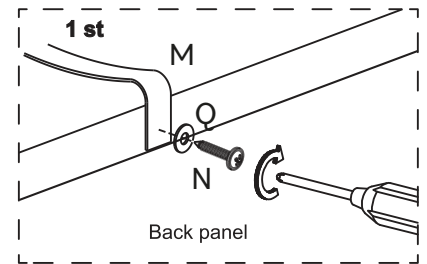
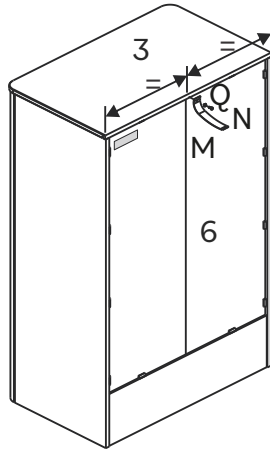

# Étape / Paso 21

(FR)

Dernière étape ! Insérez la douille en plastique (O) dans le mur. Fixez ensuite la ruban (M) au mur à l'aide de la rondelle (Q) et de la vis (P).

(ES)

¡Último paso! Inserte el casquillo de plástico (O) en la pared. Luego, fije el cinta (M) a la pared con la arandela (Q) y el tornillo (P).

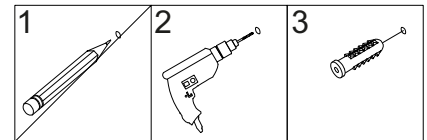
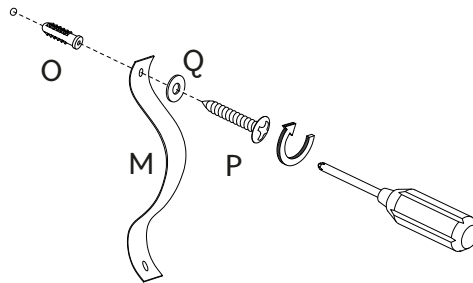

## Avertissement

Des blessures graves, voire mortelles, peuvent survenir en cas de renversement de meubles. Pour éviter que le meuble ne bascule, nous recommandons de le fixer définitivement au mur. L'ancrage mural et les autres composants sont inclus dans ce produit. Assure-toi que les composants sont adaptés à tes murs avant l'installation, car différents matériaux de mur peuvent nécessiter différents types d'ancrages.

Le nom et l'adresse du fabricant responsable des composants anti-basculer ainsi que la date de production se trouvent sur l'étiquette au dos du meuble.

## Advertencia

Pueden ocurrir lesiones graves o fatales debido a la caída de muebles. Para evitar que los muebles se caigan, recomendamos que se fijen permanentemente a la pared. El anclaje de pared y los herrajes están incluidos en este producto. Asegúrate de que los herrajes sean adecuados para tus paredes antes de la instalación, ya que diferentes materiales de pared pueden requerir diferentes tipos de anclajes.

El nombre y la dirección del fabricante responsable de los herrajes antivuelco y la fecha de producción se pueden encontrar en la etiqueta de la parte trasera de los muebles.

# À démonter / Para desmontar



(FR)

S'il est nécessaire de démonter, retirez le Dovetail Lock (B) à l'aide d'un tournevis à tête plate.

(ES)

Si es necesario desmontarlo, retire el Dovetail Lock (B) con un destornillador de cabeza ranurada.

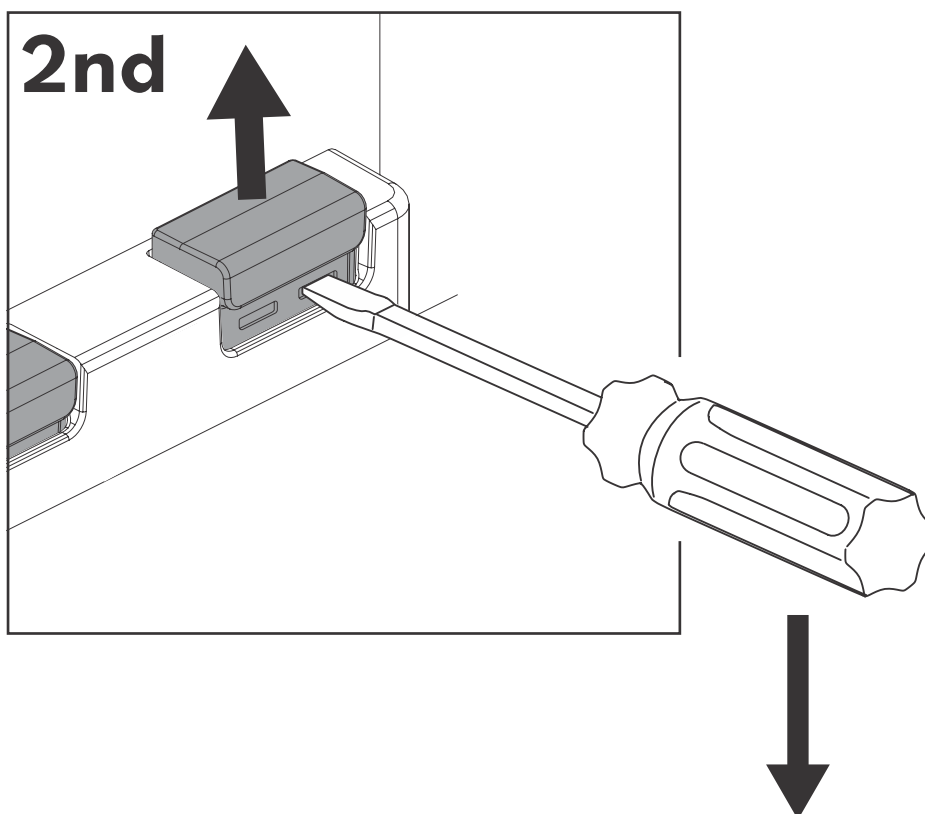
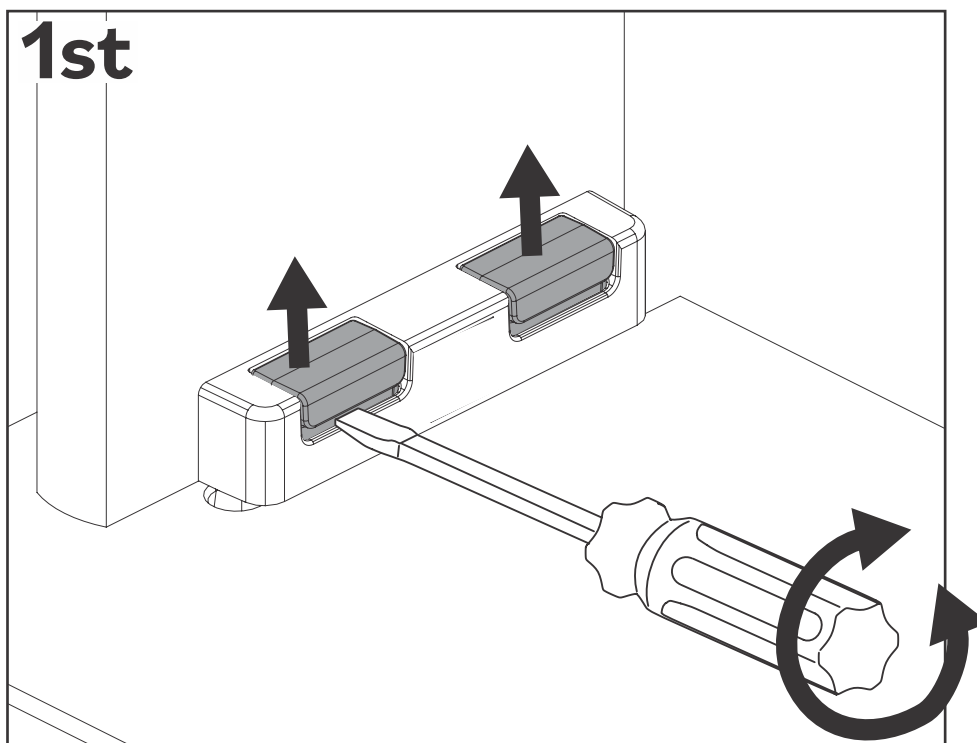

Tu as réussi! Profite de ton nouveau Commode!  
¡Lo ha conseguido! ¡Disfrute de su nueva Cómoda!

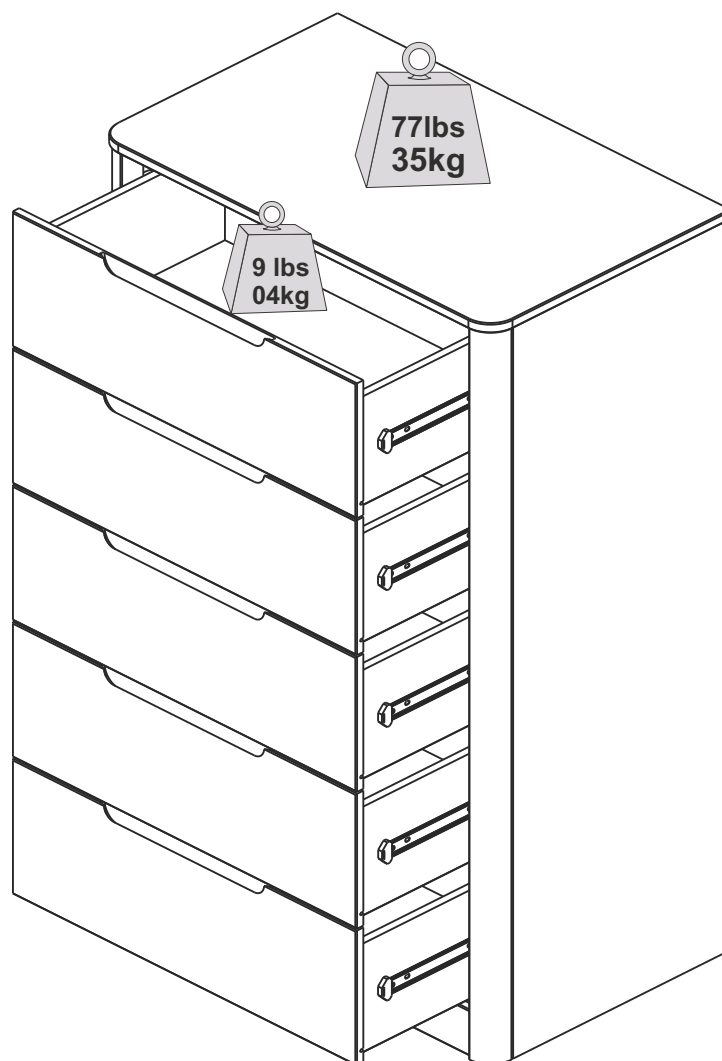

**Bravo pour ton nouveau meuble !**

**¡Enhorabuena por sus nuevos muebles!**