

20X40 FT Carport

Instructions for Assembly

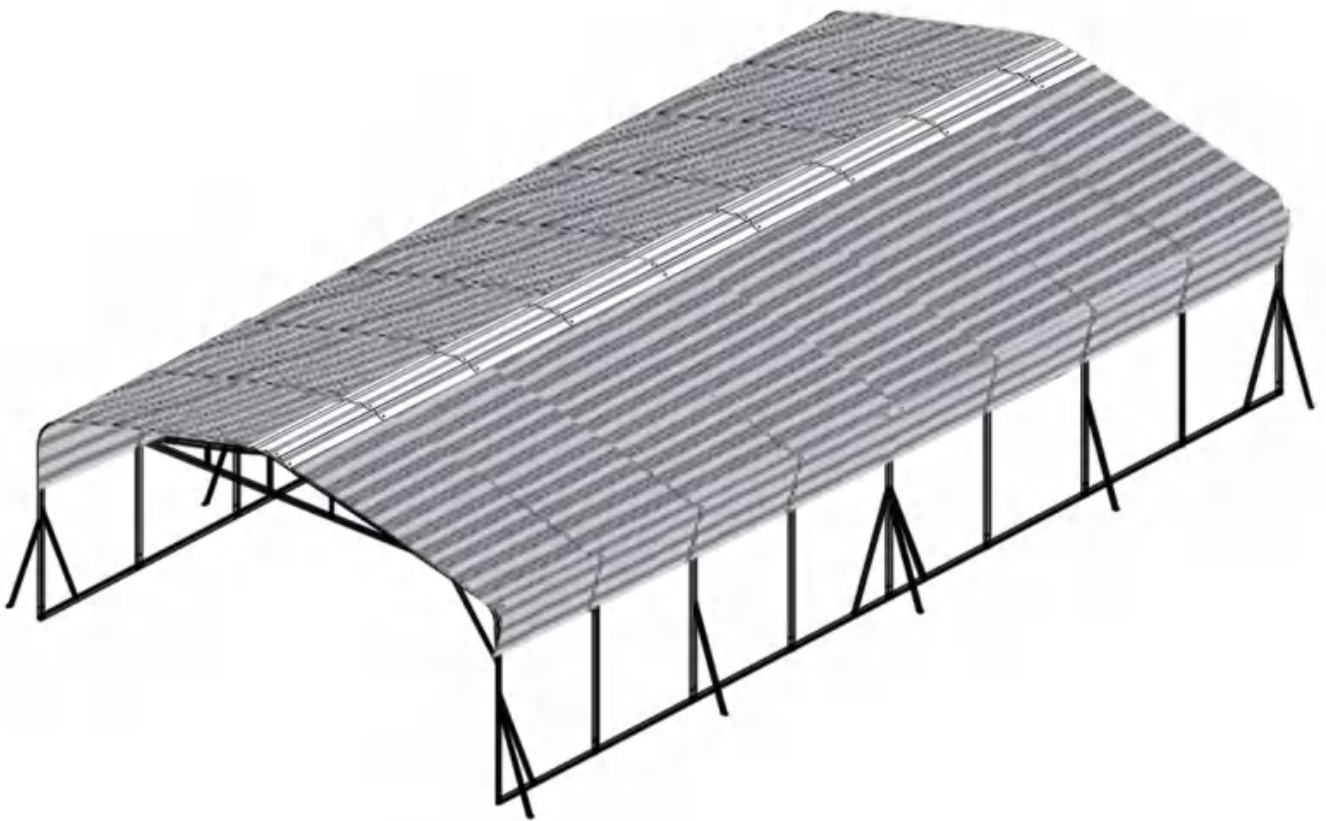





Minimum of 3 People is required for a safe assembly of the product

You will receive nine separate boxes for this product to be fully assembled. Please make sure all boxes arrived in good condition before assembling. It happens sometimes when boxes arrive separately due to postponed carrier's shipping, and your patience is really appreciated!

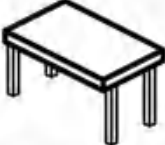
If you encounter any problems during the assembly process, contact us anytime !
support@sylviera.com

REQUIRED TOOLS

Tools			
	Gloves	Table	Ladder
			
	Power drill	Screw drive	Tape Measure

ASSEMBLY TIPS







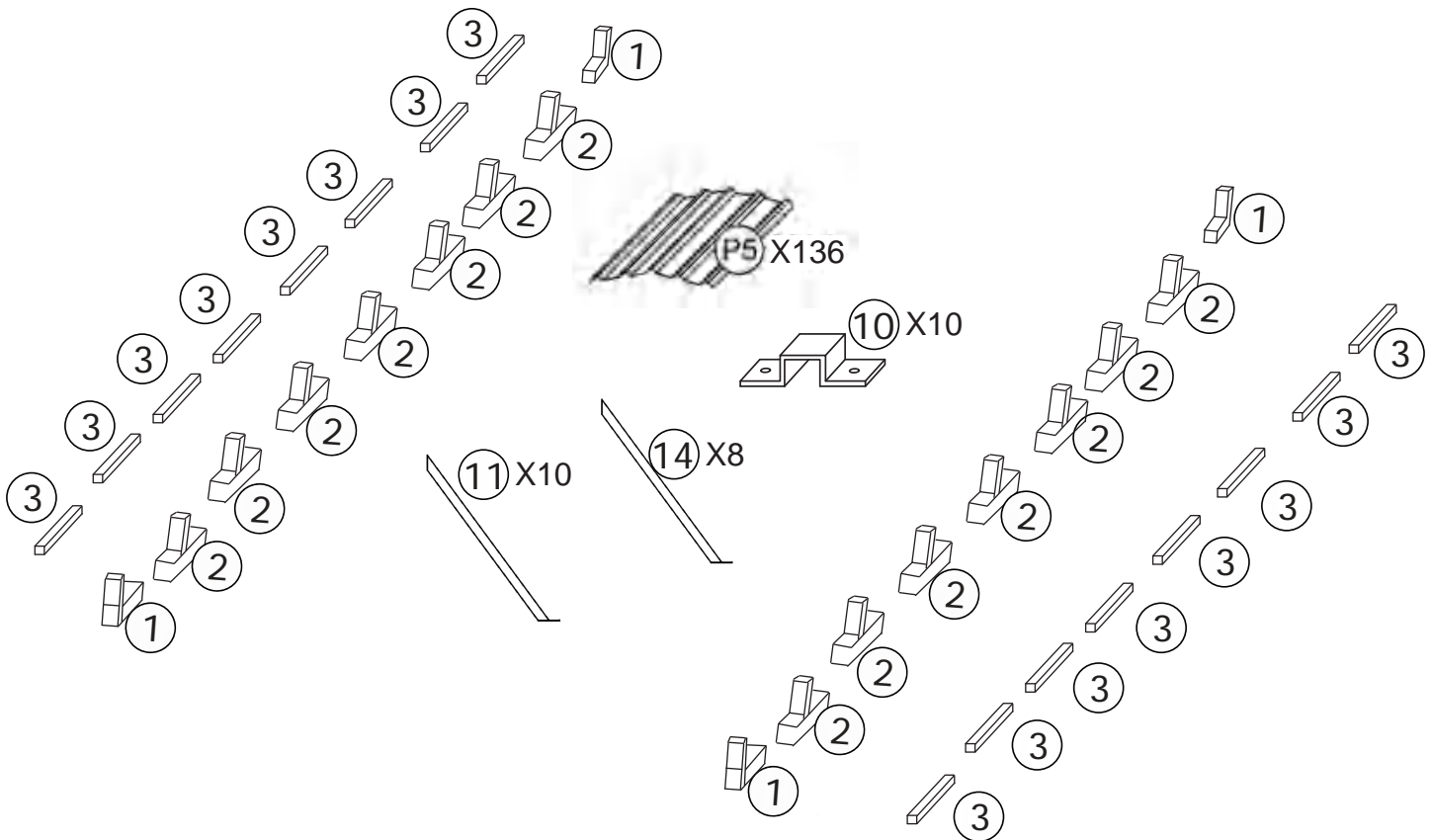
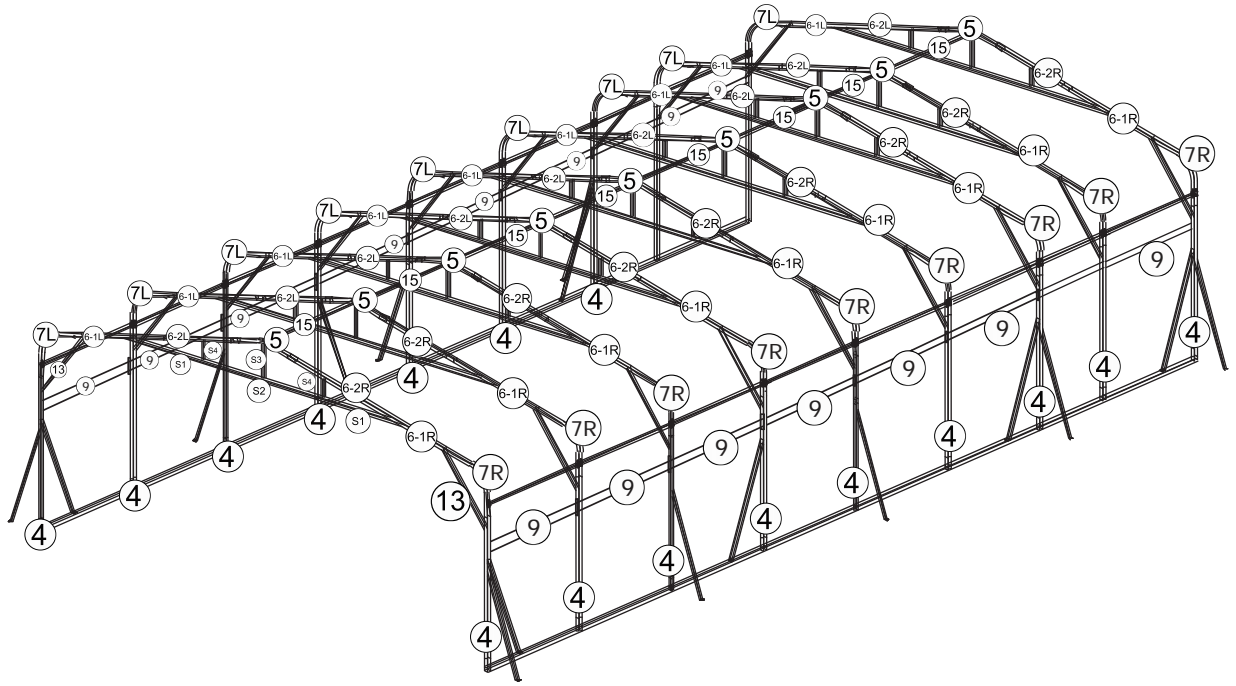



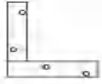



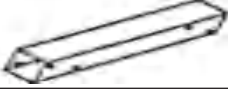







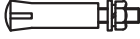



1. Clear a working area to allow access on all four sides. A raised work surface will make assembly easier. It is easier to install the wall panel on the table.
2. All parts are identified, so when working through the instructions page by page, the diagrams show where each part is positioned.
3. Before starting, to avoid any accidental injury, we recommend the use of gloves to protect your hands.
4. Please keep children away from your construction site.
5. Most assembly can be completed by one person, but assistance may be needed when you reach the erection stage.
6. Please note: Some local government authorities have rules & regulations on shed installation, and you may need approval to erect this shed.

ASSEMBLY STEPS

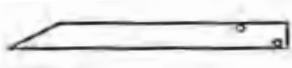

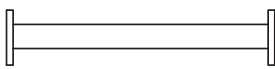
1. Unpack all components from the carton and lay them out beside your work area. Check parts against the parts list.
2. Work through the assembly instructions page by page.
3. Once assembly is completed, place the shed in position and fix the anchor to the ground.
4. Clean up all metal pieces and screws.

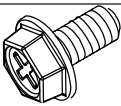

Hardware List

IMAGE	NO.	QTY	IMAGE	NO.	QTY
	1	X4		10	X10
	2	X14		11	X10
	3	X16		P5	X136
	4	X18		F3	X1160
	5	X9		F4	X1
	6-1L	X9		F11	X4
	6-1R	X9		F8	X30
	7L	X9		F9	X2
	7R	X9		F5	X2
	6-2L	X9		adhesive tape	X3
	6-2R	X9		S1	X18
	S2	X9		S3	X9
	9	X16		S4	X18
	F10	X128		F12	X38

Hardware List

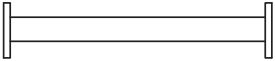
IMAGE	NO.	QTY	IMAGE	NO.	QTY
	13	X18		14	X8
	15	X8			

STEP 1

Note:6-1L and 6-1R hole orientations, connected to the S1 part;

Note:6-2L and 6-2R hole orientations, connected to the S4 part;

Note:5 hole orientations, connected to the S3 part;

Note: There are two hole positions on the bottom of both 7L and 7R for connecting Part 9. Do not install them in the reverse direction.

X9

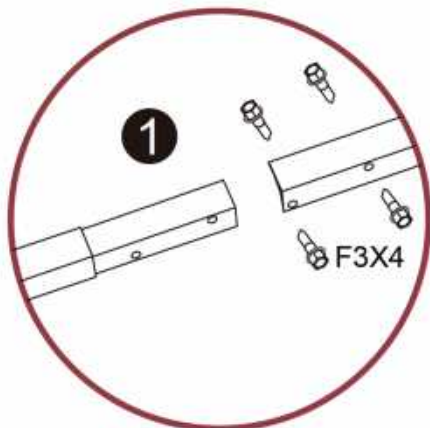
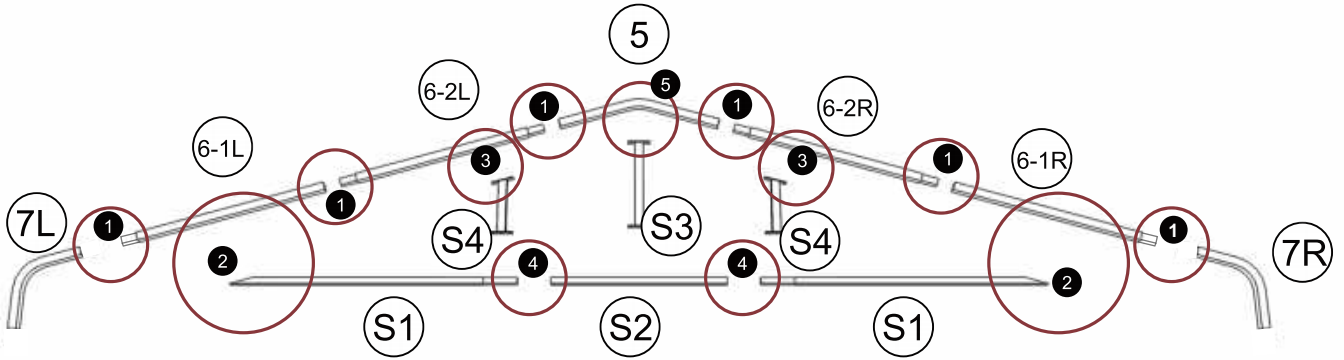

X6

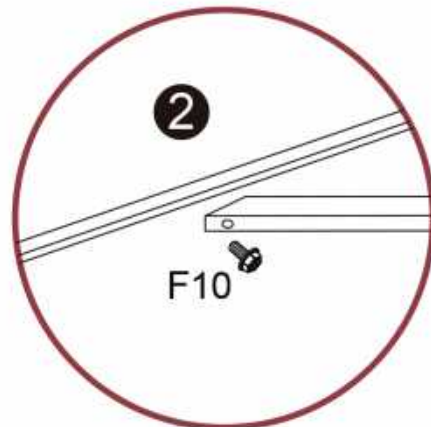

X2

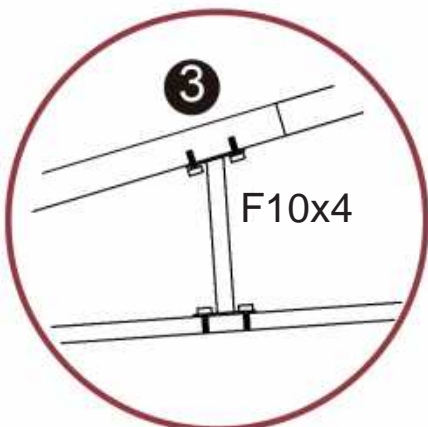

X2

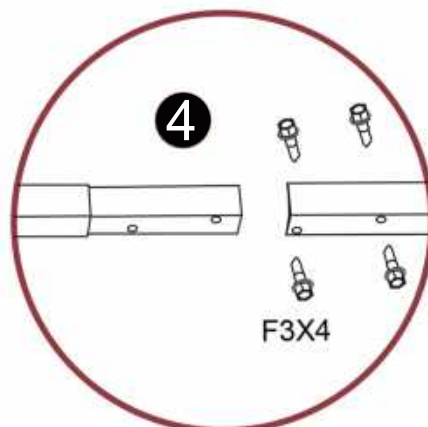

X2

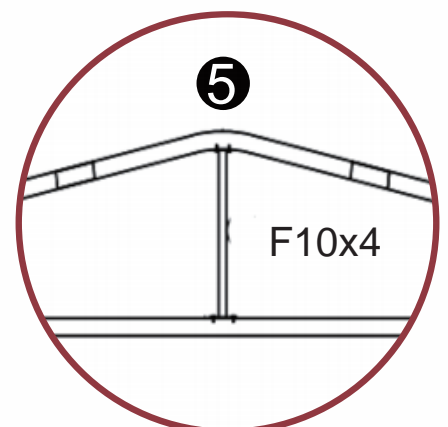

X1

F10		x126	F3		x288
-----	--	------	----	--	------

STEP 2

X9

Note: No. 4 column rod with hole position facing inward

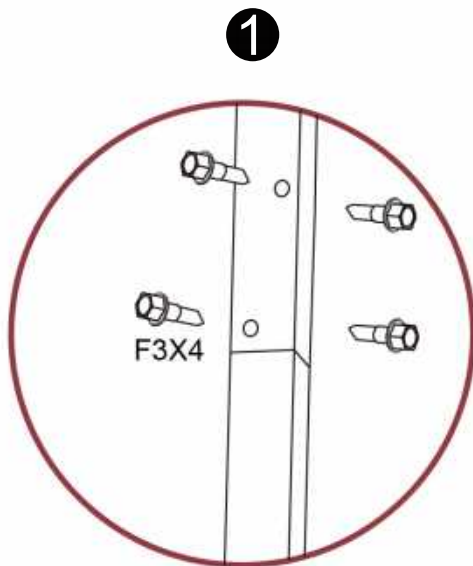
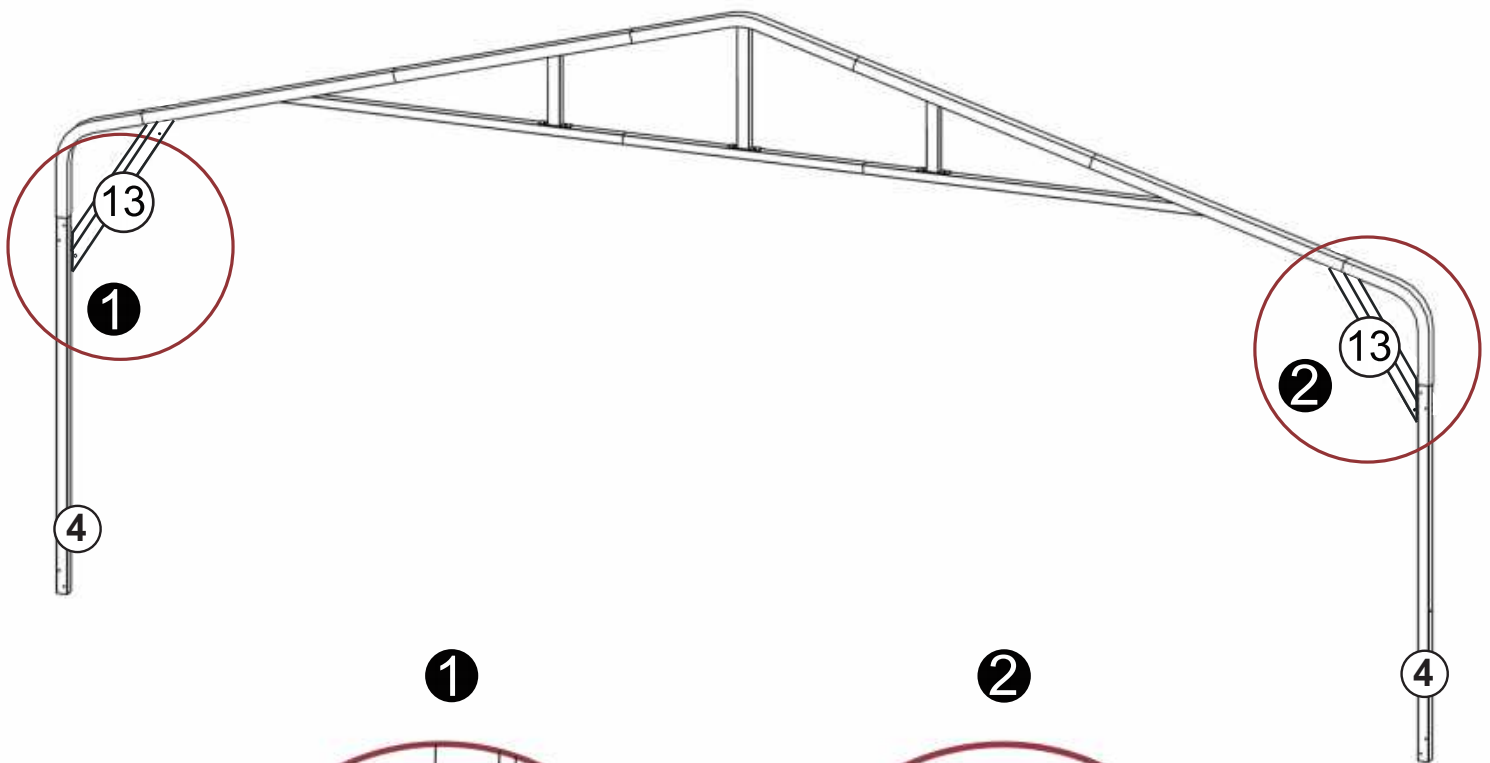

X2

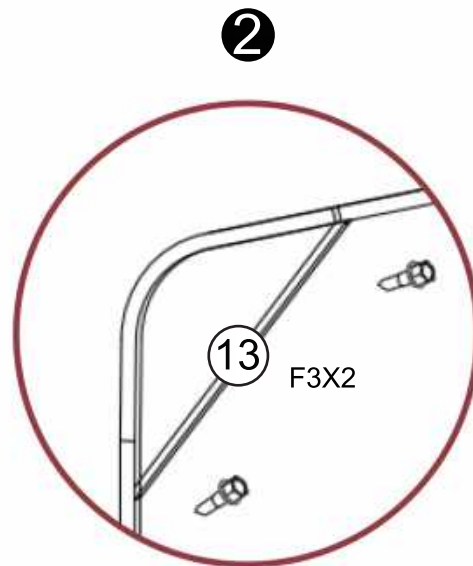

X2

F12		X36
-----	---	-----

F3		X72
----	---	-----

STEP 3

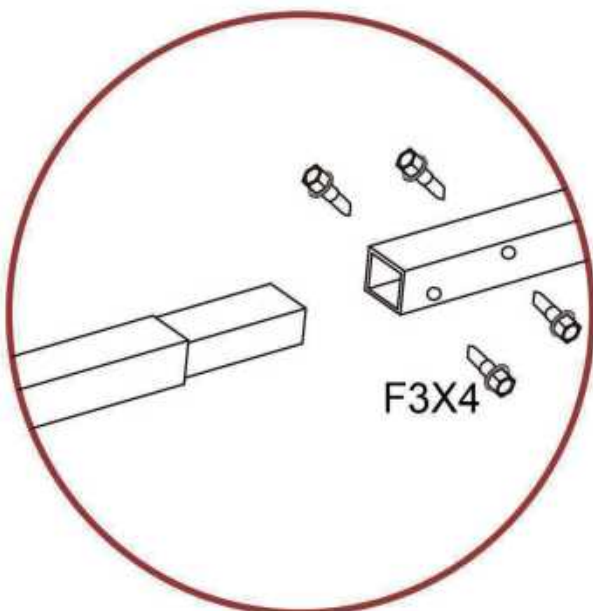
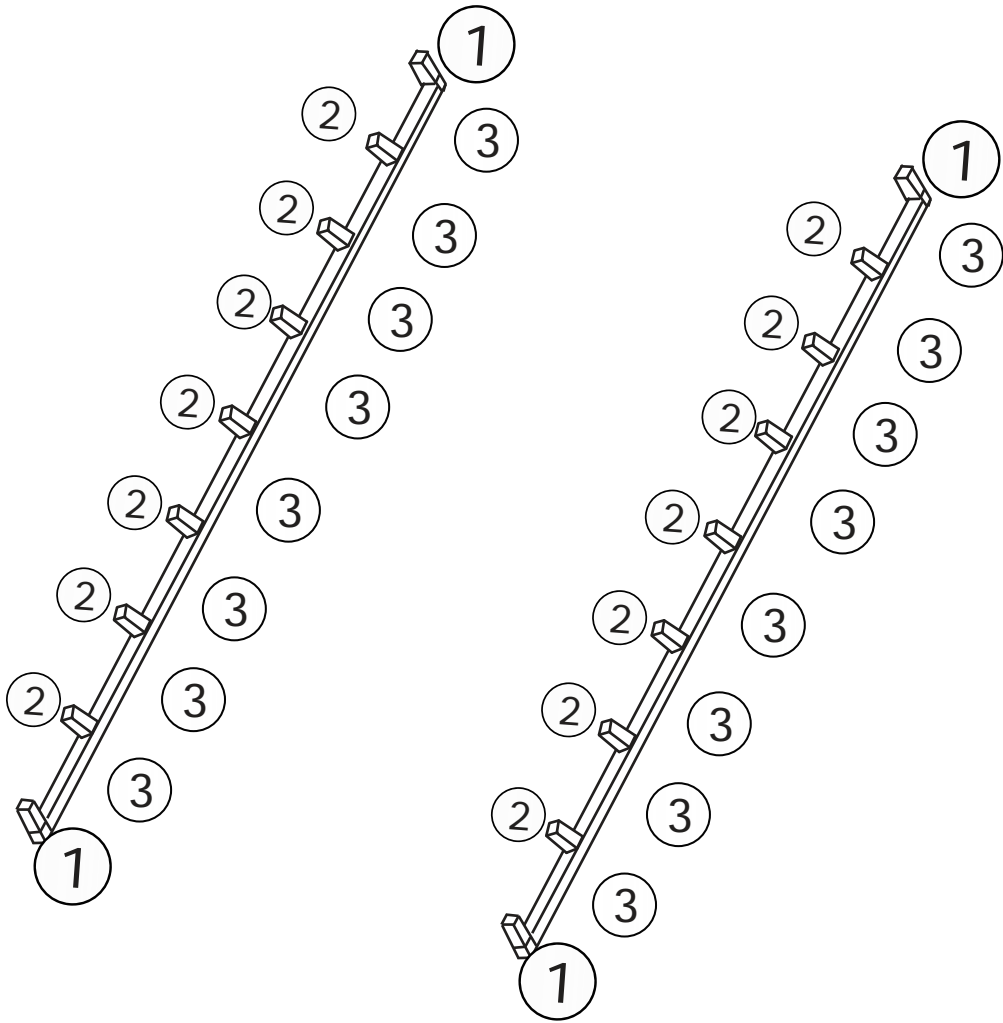

X32

STEP 4

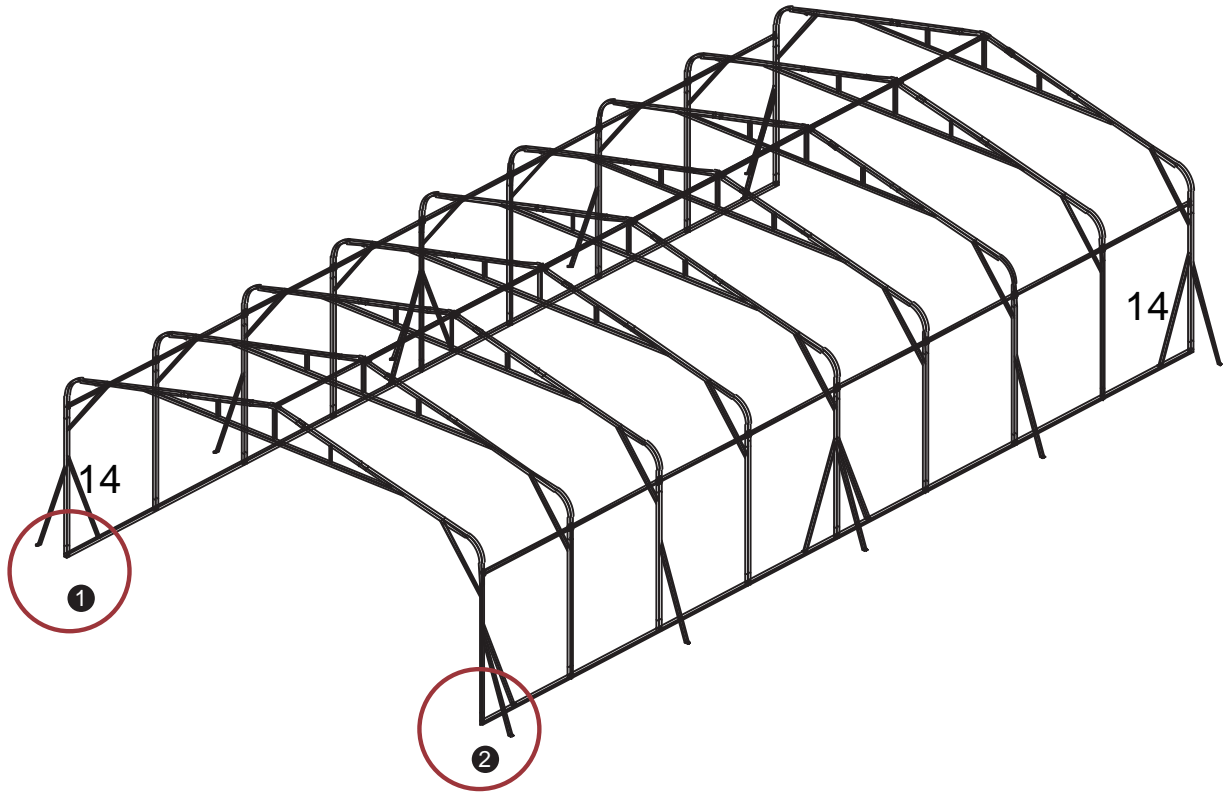

1

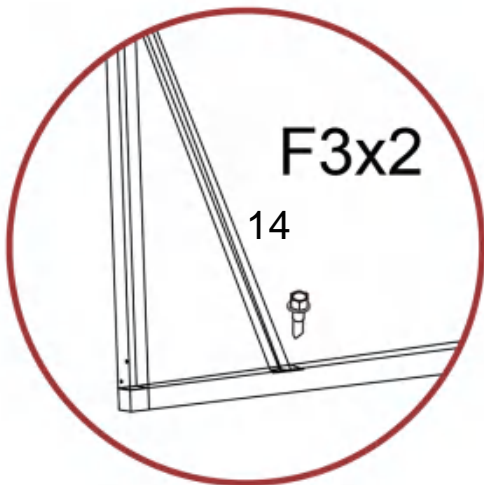

X8

2

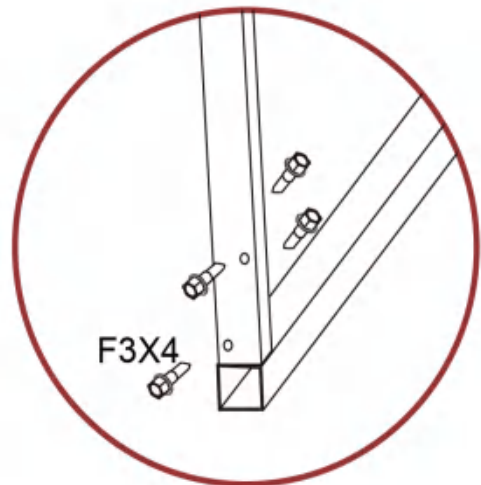

X18

F3		x88
----	---	-----

STEP 5

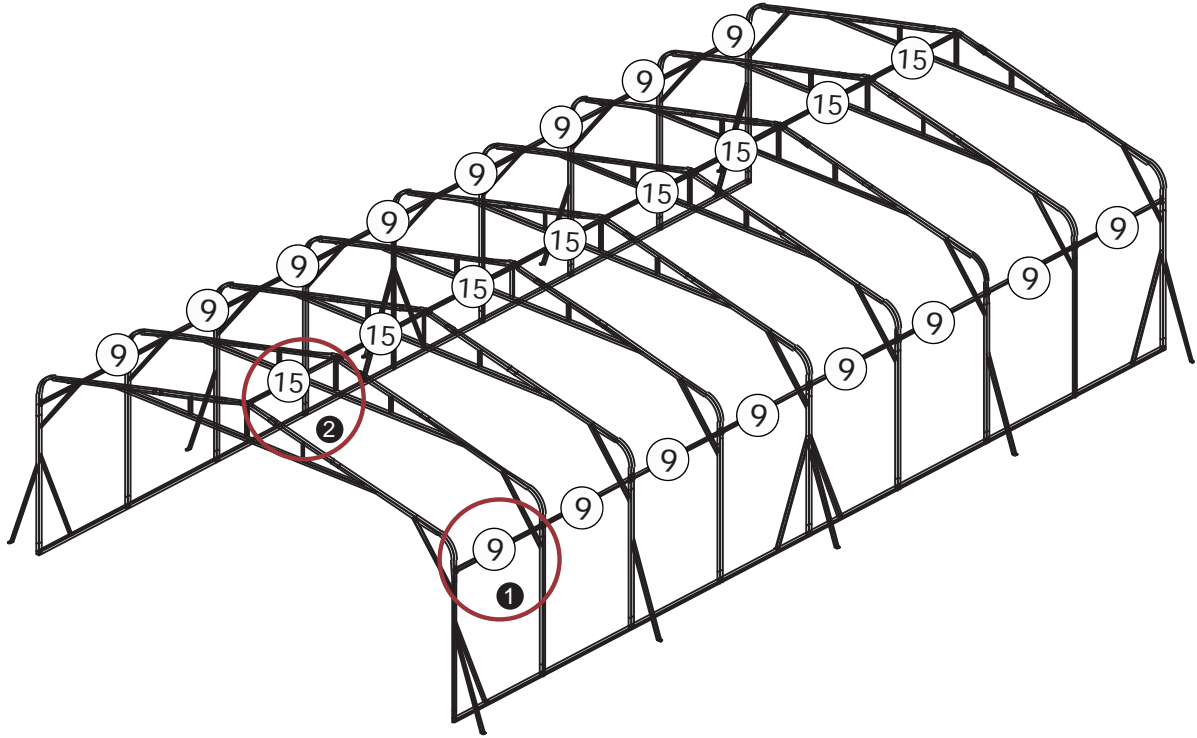

1

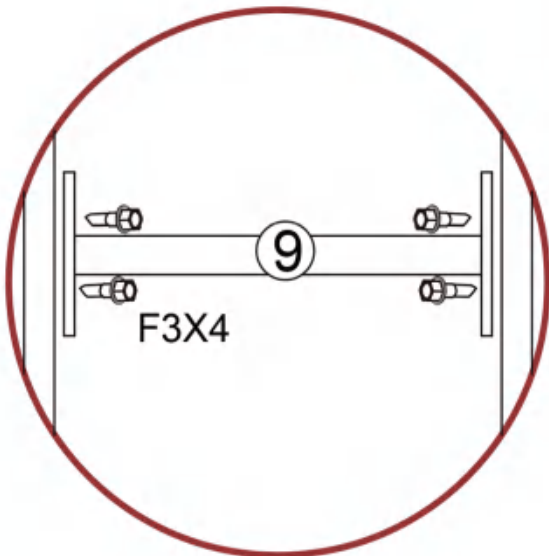

X16

2

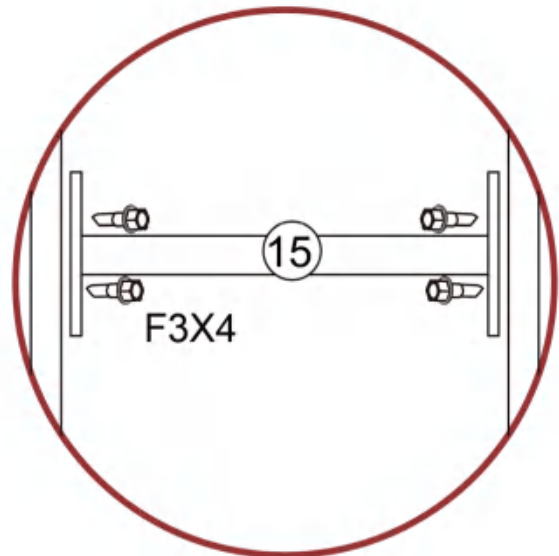

X8

STEP 6

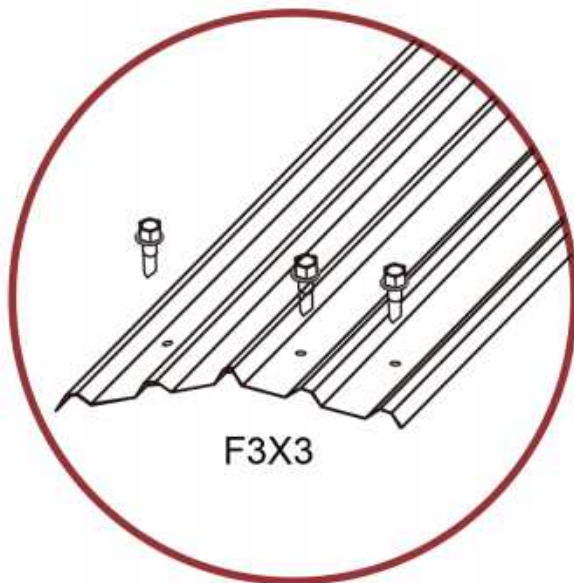
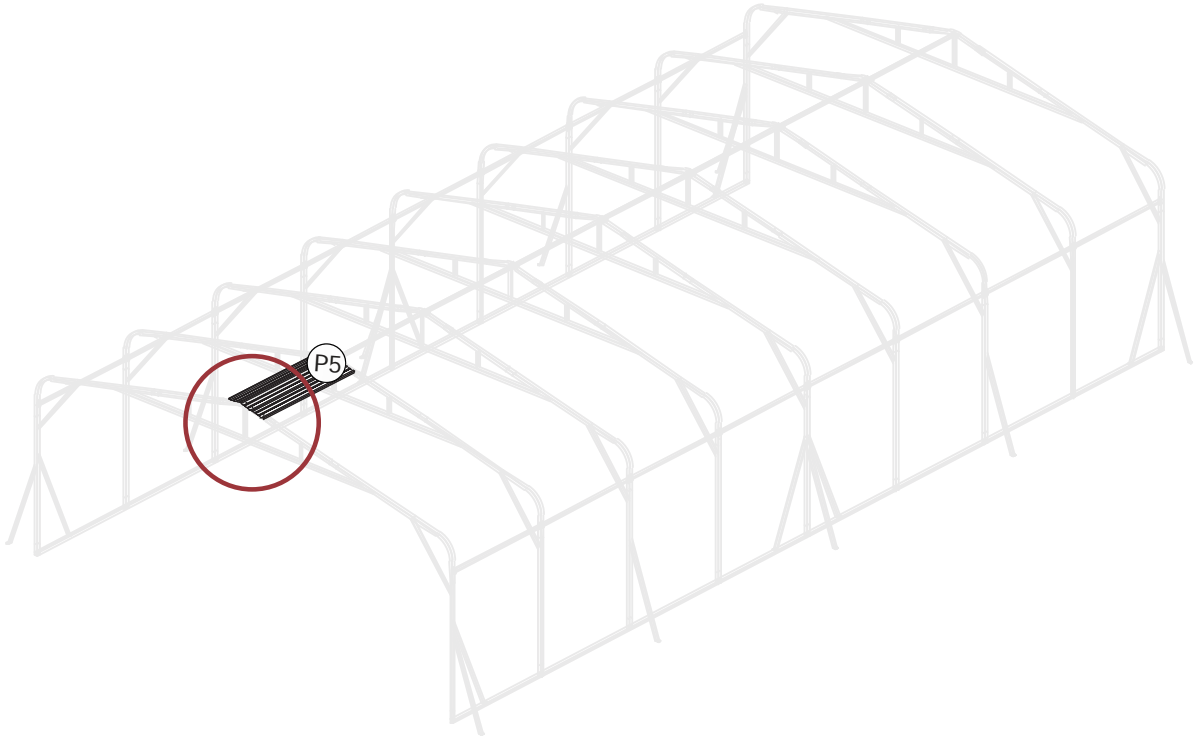

F3		X3
----	---	----

STEP 7

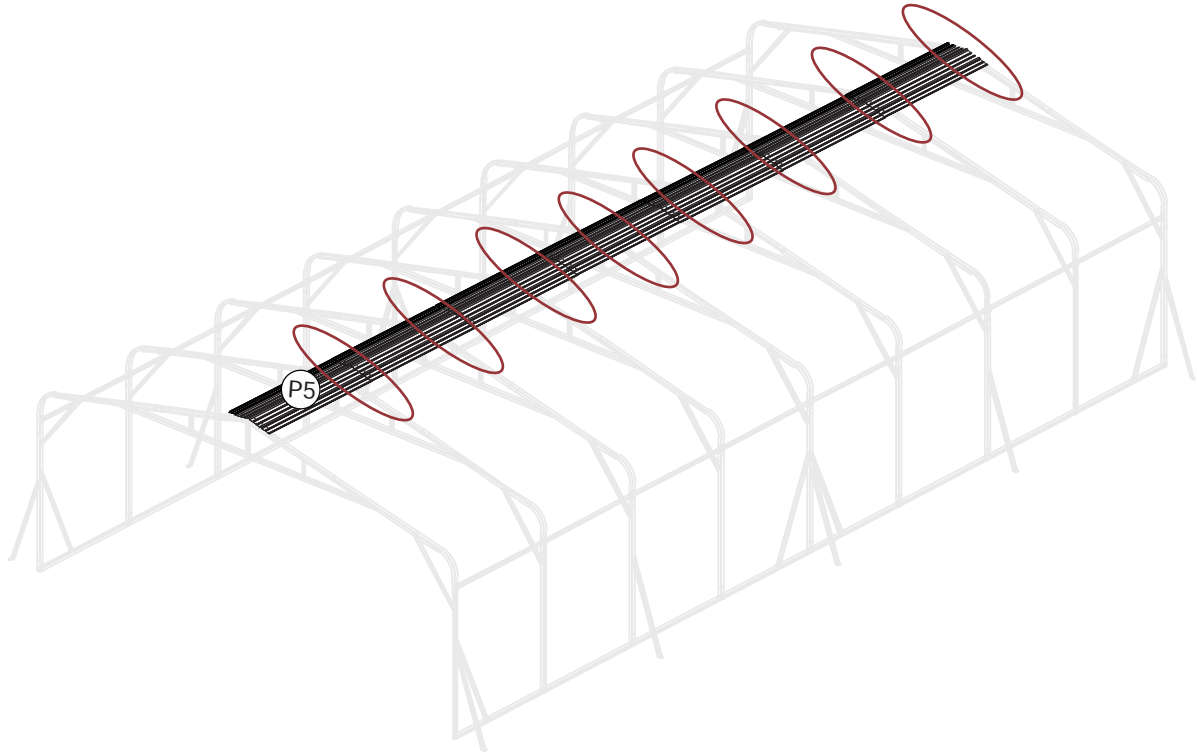

Apply a layer of waterproof tape to the outside of the seams of the two layers of tin, which can effectively prevent leakage of the carport

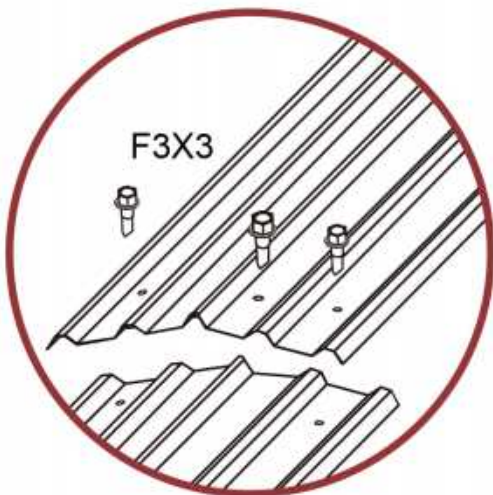

X8

F3		x24
----	---	-----

STEP 8

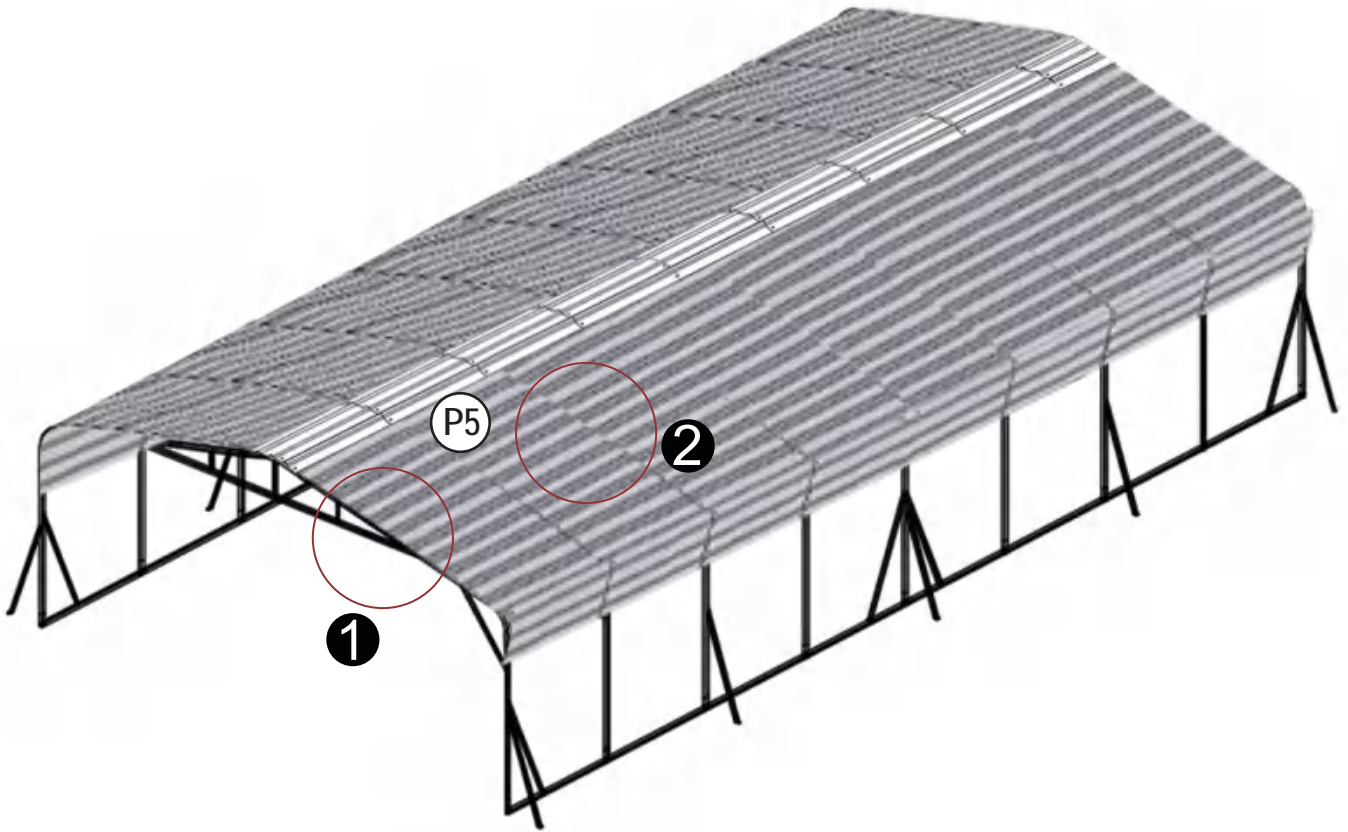

1

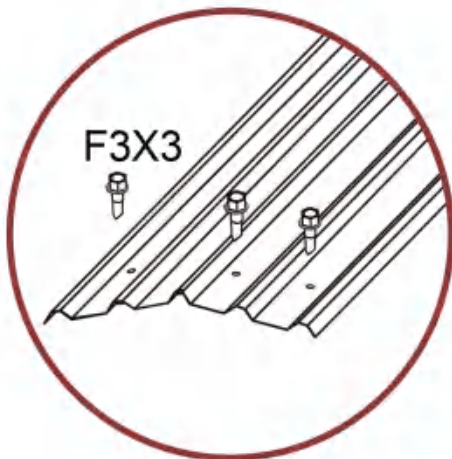

2

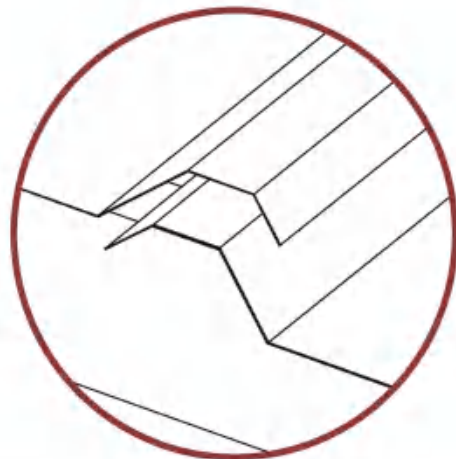

STEP 9

Note: After the P5 is installed, the waterproof tape is glued to the connection of the color steel tile of each gear to prevent water leakage.

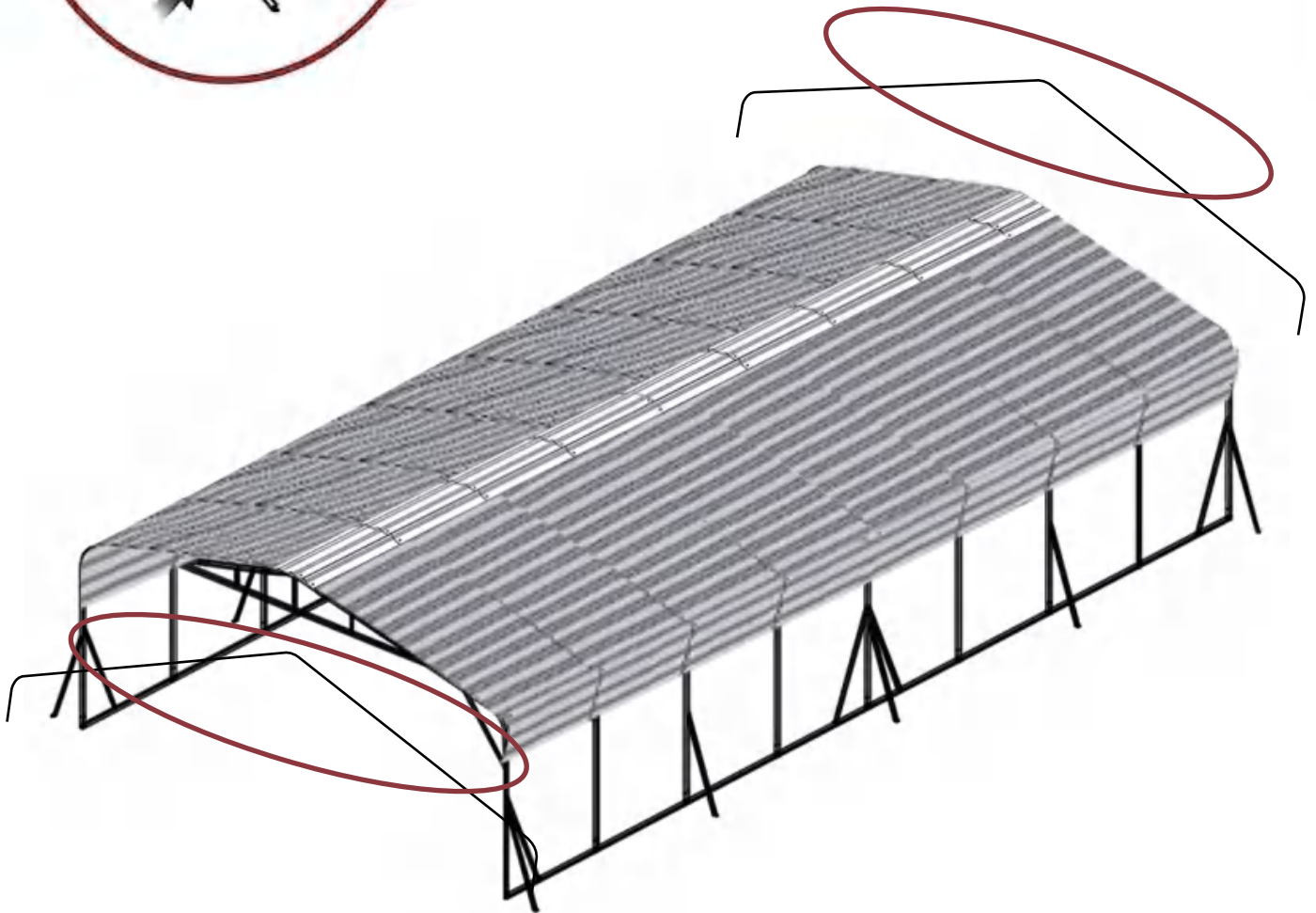
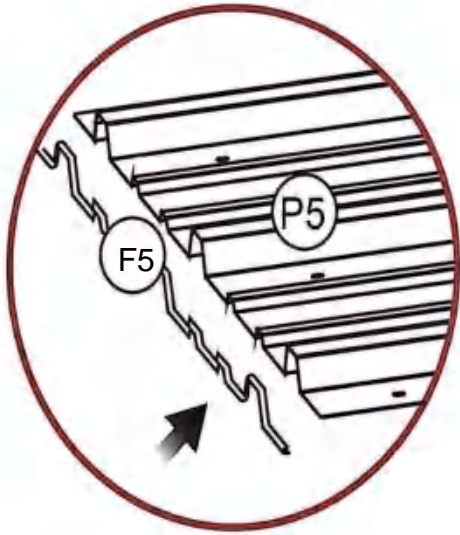

STEP 10

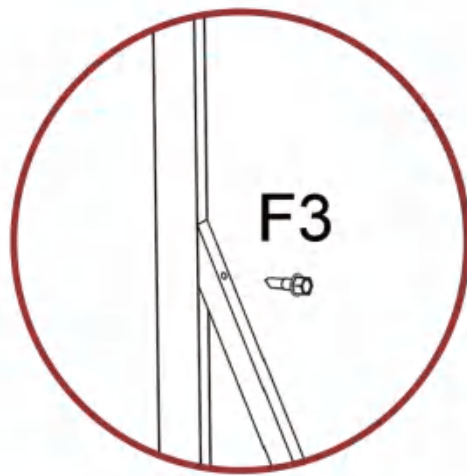
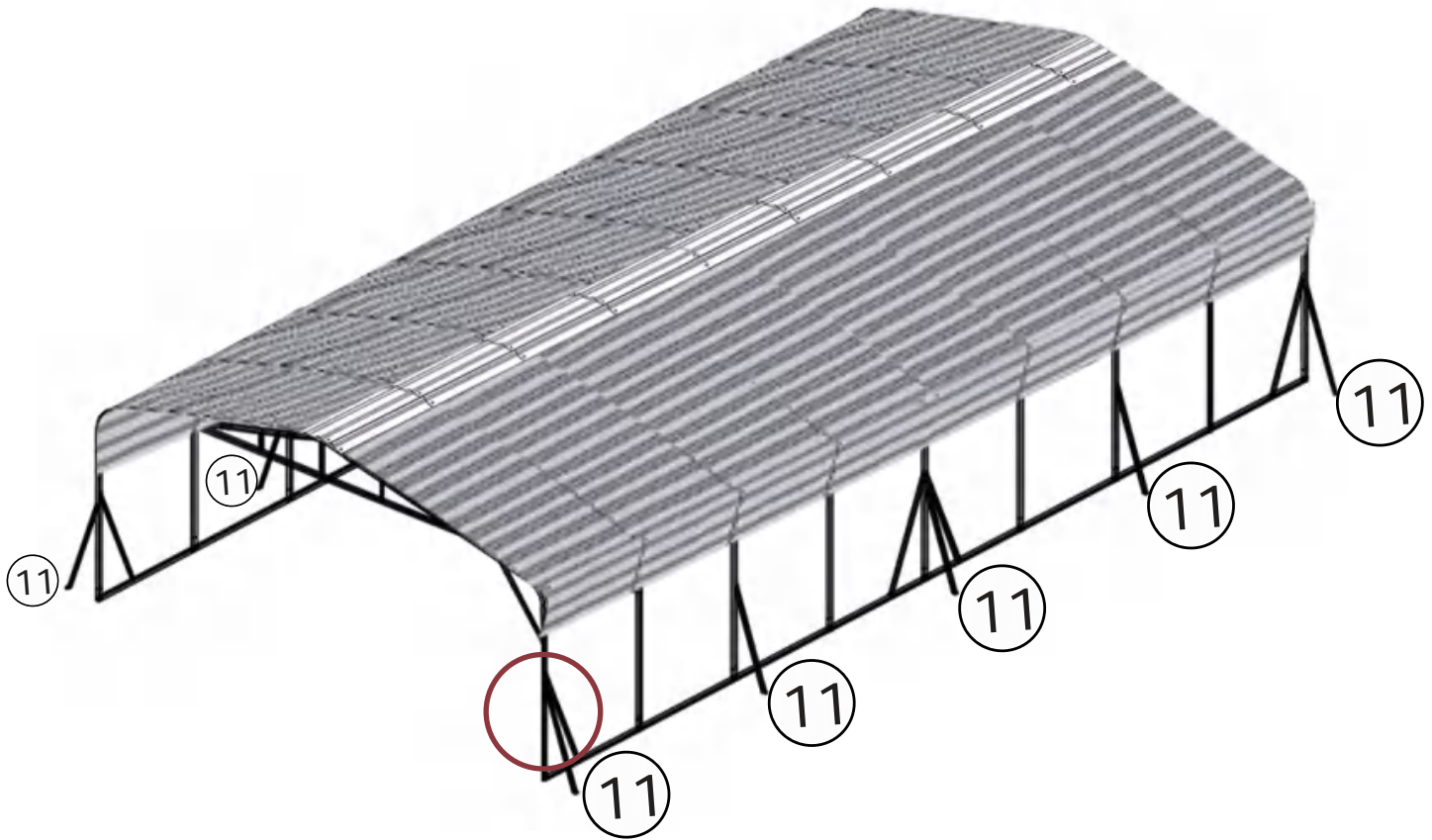

X10

F3		x10
----	---	-----

STEP 11

Note: Before installing the F8, make sure the overall product size is consistent. If not, adjust it to prevent the product from shaking.

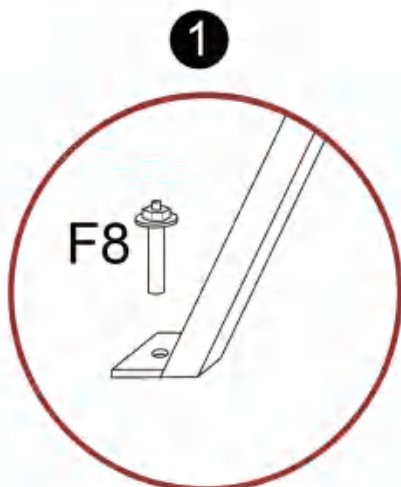
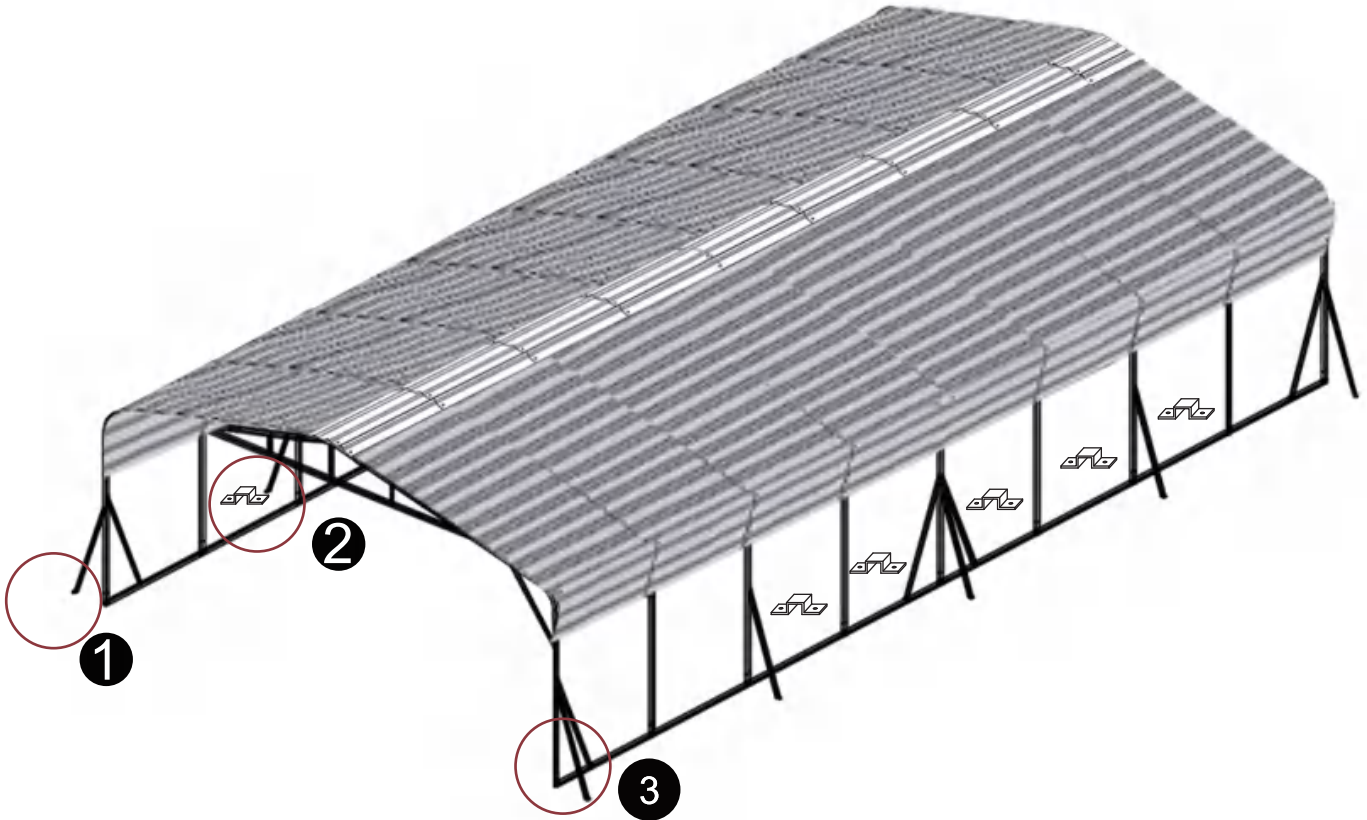

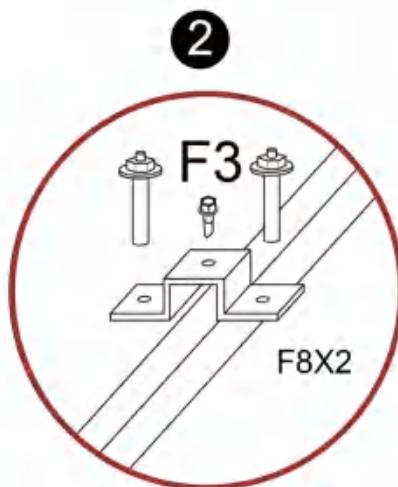

X10

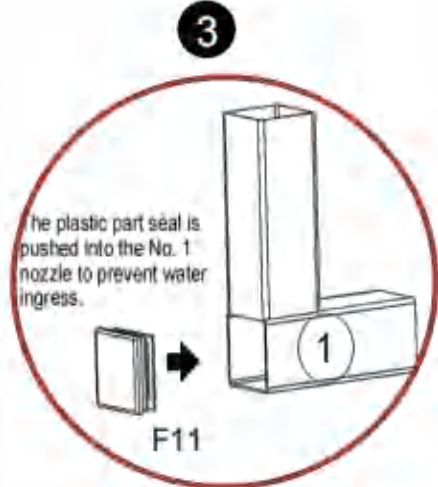

X10

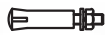

X4

F8		x30
F3		x10