

# ASSEMBLY INSTRUCTIONS

## Fiesta Dining Chair Item# 45218

ASSEMBLY  
REQUIREMENTS

2-Person  
Assembly

30 Minutes  
Assembly Time  
(Approximate)

Tools Required:  
(Not Provided)

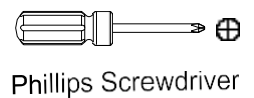
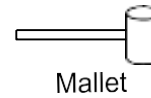

### Thank you for purchasing our product!

Please refer and use this assembly instruction to assemble the product. Contact our customer service department in case there any missing or damage parts or hardware. Replacement parts are normally shipped within 2 or 3 days.

Email: [replacementparts@buylateral.com](mailto:replacementparts@buylateral.com)  
Within 30 days from delivery date

**PRODUCTS PURCHASED THROUGH OUR AUTHORIZED VENDORS ONLY ARE ELIGIBLE FOR REPLACEMENT PARTS**

We appreciate your business!

**THIS PRODUCT IS FOR INDOOR AND HOUSEHOLD USE ONLY  
– NOT FOR COMMERCIAL USE.**

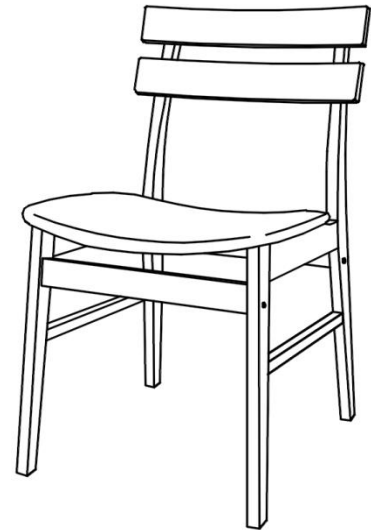

### ASSEMBLY PREPARATION

1. Remove all packaging materials, staples and packing straps from the carton.
2. Refer to Parts List and Hardware List, and ensure parts and hardware are correct before assembly. Contact customer service for missing parts.
3. Place all wooden parts on a clean, flat and soft surface (e.g. carpet or rug) to prevent scratch and damage to parts.

### SAFETY PRECAUTION

1. KEEP ALL HARDWARE PARTS OUT OF REACH OF CHILDREN.
2. DISPOSE PLASTIC PACKAGING MATERIAL IMMEDIATELY TO AVOID ANY RISK OF SUFFOCATION TO CHILDREN AND ANIMALS.

### TIPS FOR ASSEMBLY

1. Allow ample room for assembly and in close proximity to where product will be placed.
2. Assemble the product on a surface that does not scratch or damage the exterior gloss and finish of the furniture.
3. Identify all of the parts, hardware and quantities required for each step.
4. During assembly, do not over-tighten any fittings as this may cause damage.
5. DO NOT USE POWER TOOLS TO ASSEMBLE THIS PRODUCT.
6. Always place the product on a flat, level surface.
7. Do not sit or stand on the partially assembled product; only use the product for which it is intended.

### CARE AND MAINTENANCE

- Use a slightly damp cloth to clean the product. Do not use bleach or abrasive cleaning material.
- Check all the fittings periodically and re-tighten as necessary. Do not use the product if any of the parts is damaged or broken.
- Never allow any kind of liquid to remain on your furniture. Absorption can cause wood to warp or delaminate.
- Do not place hot items (e.g. hot drinks) directly onto the wood surface.
- Do not drag and/or pull the furniture.









# ASSEMBLY INSTRUCTIONS

## Fiesta Dining Chair Item# 45218

### PARTS LIST (For 1 Chair)

Item	Description	Qty
1	Upper Backrest	1
2	Lower Backrest	1
3	Front Stretcher	1
4	Back Stretcher	1
5	Right Frame	1
6	Left Frame	1
7	Cushion Seat	1

### HARDWARE LIST (For 1 Chair)

Item	Description	Part	Qty	Extra
A	JCBC M6 x 25mm + S/W M6 + F/W M6 x 13mm		4	1
B	JCBC M6 x 50mm		4	1
C	Barrel Nut		4	1
D	Allen Key M4		1	
E	L-Bracket		4	
F	CSK Screw M3.5 x 12mm		8	1
G	Wood Dowel M8 x 25mm		2	1
H	Leg Stud 5/8" with Pin		4	1

Extra hardware for spare use.

## Instructions for Installing Barrel Nut

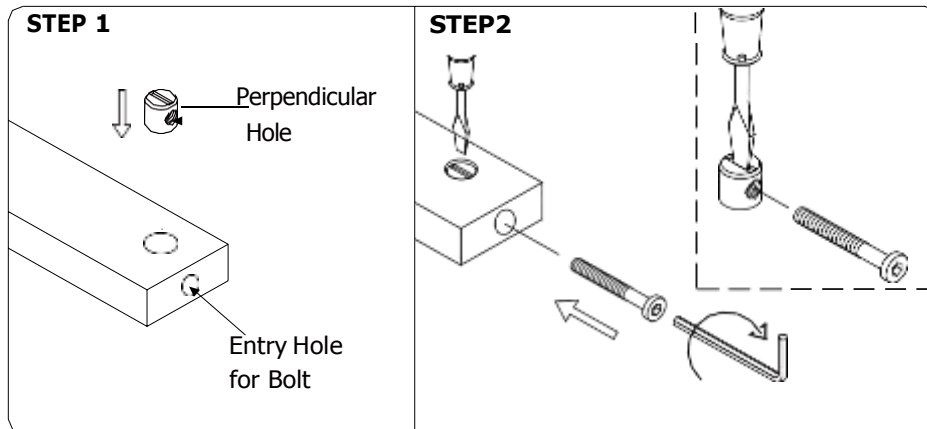

Insert Barrel Nut with the perpendicular hole facing and in-line with the drill hole that the bolt is to be inserted.

Use a Flat-head Screwdriver to hold Barrel Nut in position before inserting bolt to thread into the Barrel Nut.

## STEP 1

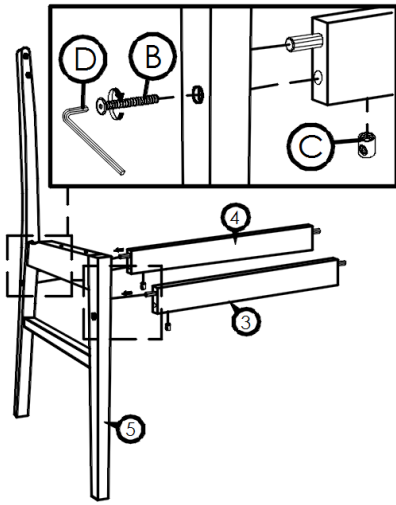

- a) Attach Front Stretcher (3) and Back Stretcher (4) to Right Frame (5).
- b) Insert Barrel Nut (C) into the hole underneath (3 & 4) and insert Bolt (B) through the hole on (5) to screw into (C). Do not tighten completely at this time. Refer to Page 2 for instructions on installing Barrel Nut.

## STEP 2

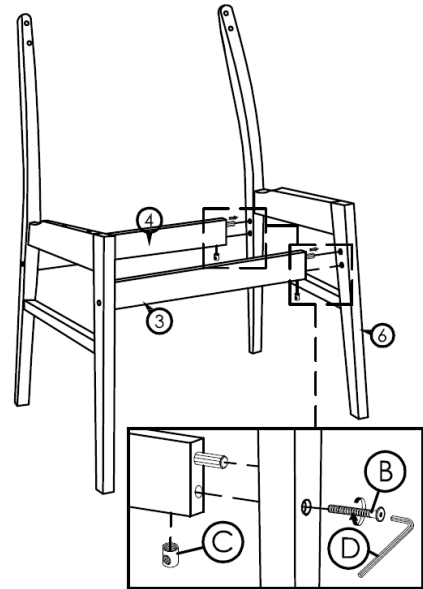

- a) Attach Left Frame (6) to Front Stretcher (3) and Back Stretcher (4).
- b) Insert Barrel Nut (C) into the hole underneath (3 & 4) and insert Bolt (B) through the hole on (6) to screw into (C). Do not tighten completely at this time.

## STEP 3

Lower Backrest (2) has a small hole for identification.

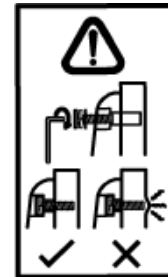
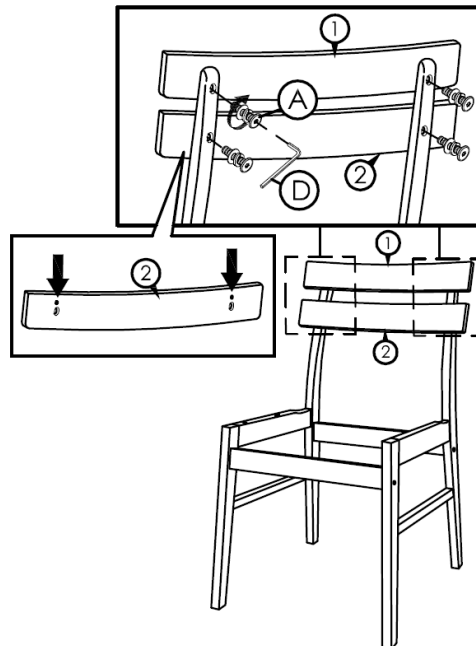

**ATTENTION: FULLY TIGHTEN THE BOLT**

- a) Align bolt holes on Lower Backrest (2) to bolt holes on backrest support section of Left and Right Frame.
- b) Insert JCBC Bolt (A) fitted with Spring Washer and Flat Washer through the hole on backrest support section to screw into the hole on (2). Use Allen Key (D) to drive (A). Do not tighten completely at this time.
- c) Use the above procedures to install Upper Backrest (1). Fully tighten Bolt (A) when all 4 bolts are in place on Lower and Upper Backrest. **DO NOT OVER-TIGHTEN.**
- d) Fully tighten all 4 Bolts (B) from STEP 1 and (2). **DO NOT OVER-TIGHTEN.**

## STEP 4

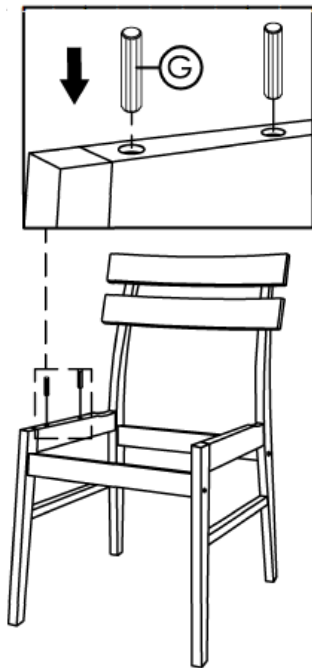

Insert Wood Dowel (G) into the designated hole on Right Frame as shown.

## STEP 5

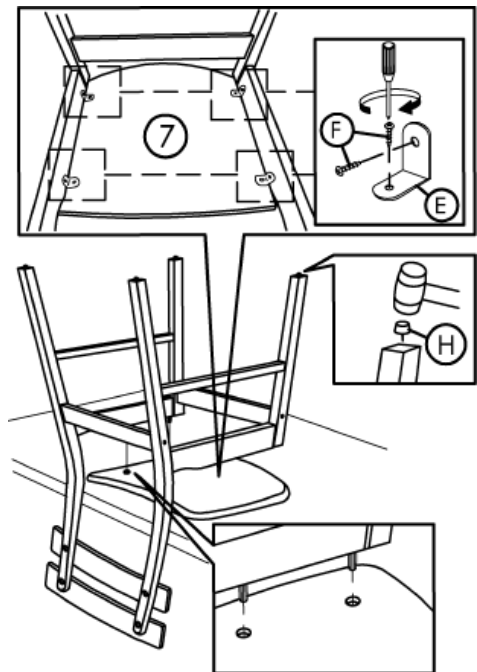

- Place the Cushion Seat (7) bottom-side up on an elevated surface (e.g. table top).
- Position the chair frame assembly as shown and attach to (7) via wood dowel on Right Frame.
- Use Screw (F) and L-Bracket (E) to fasten (7) to Right and Left Frame. Note the locations to fasten (E).
- Use a mallet to lightly tap in Leg Stud (H) to the bottom of each Leg.

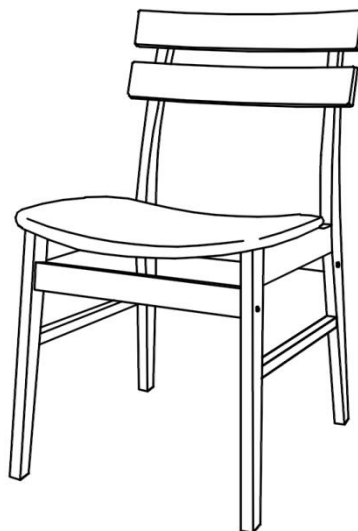

Set the chair right-side up.

The assembly of the chair is complete.