

Installation & Assembly

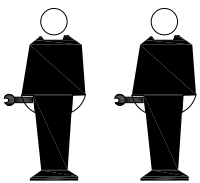

For convenience and safety, we recommend two people to assemble.
If you have any questions, please contact our customer service.

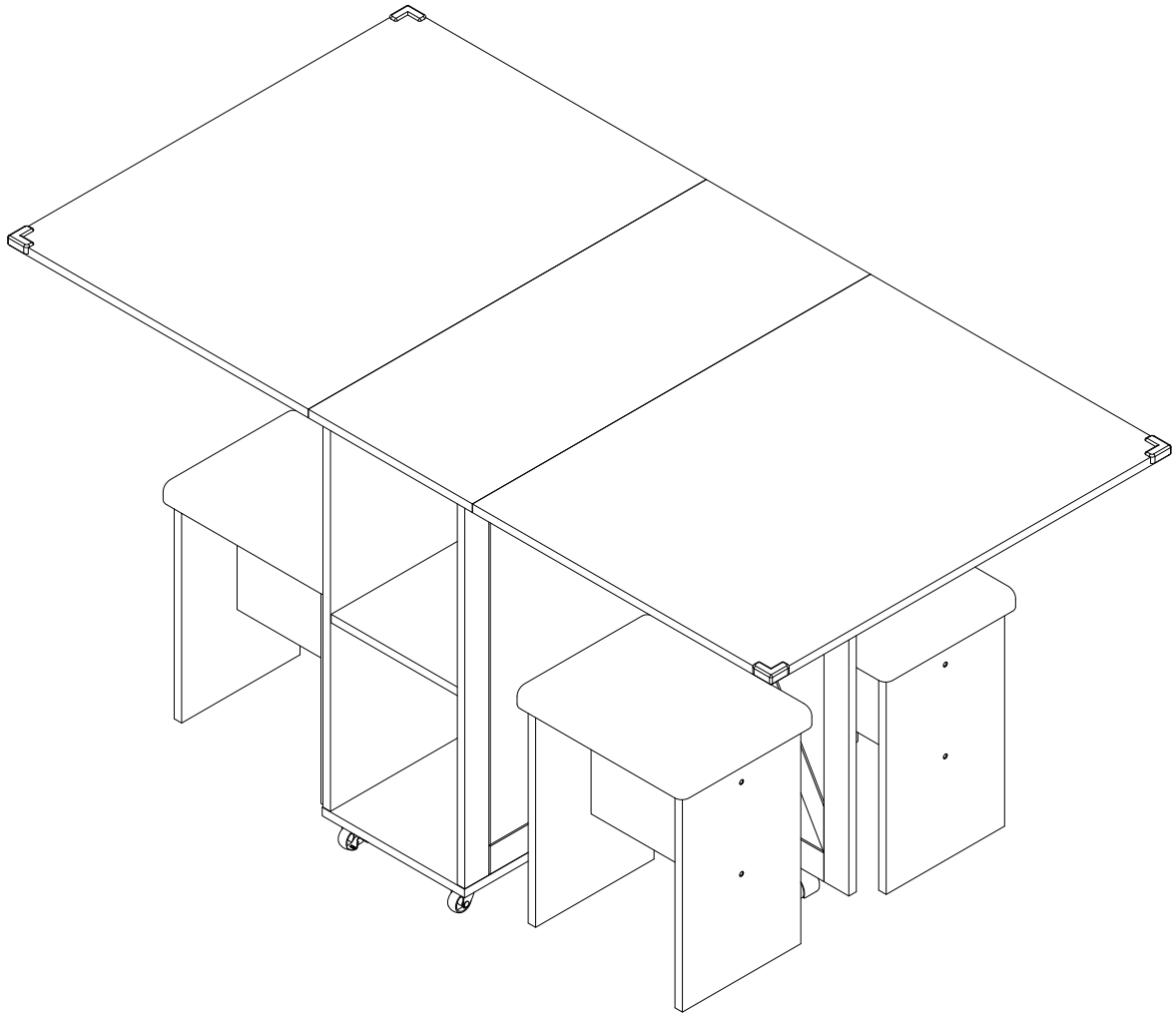
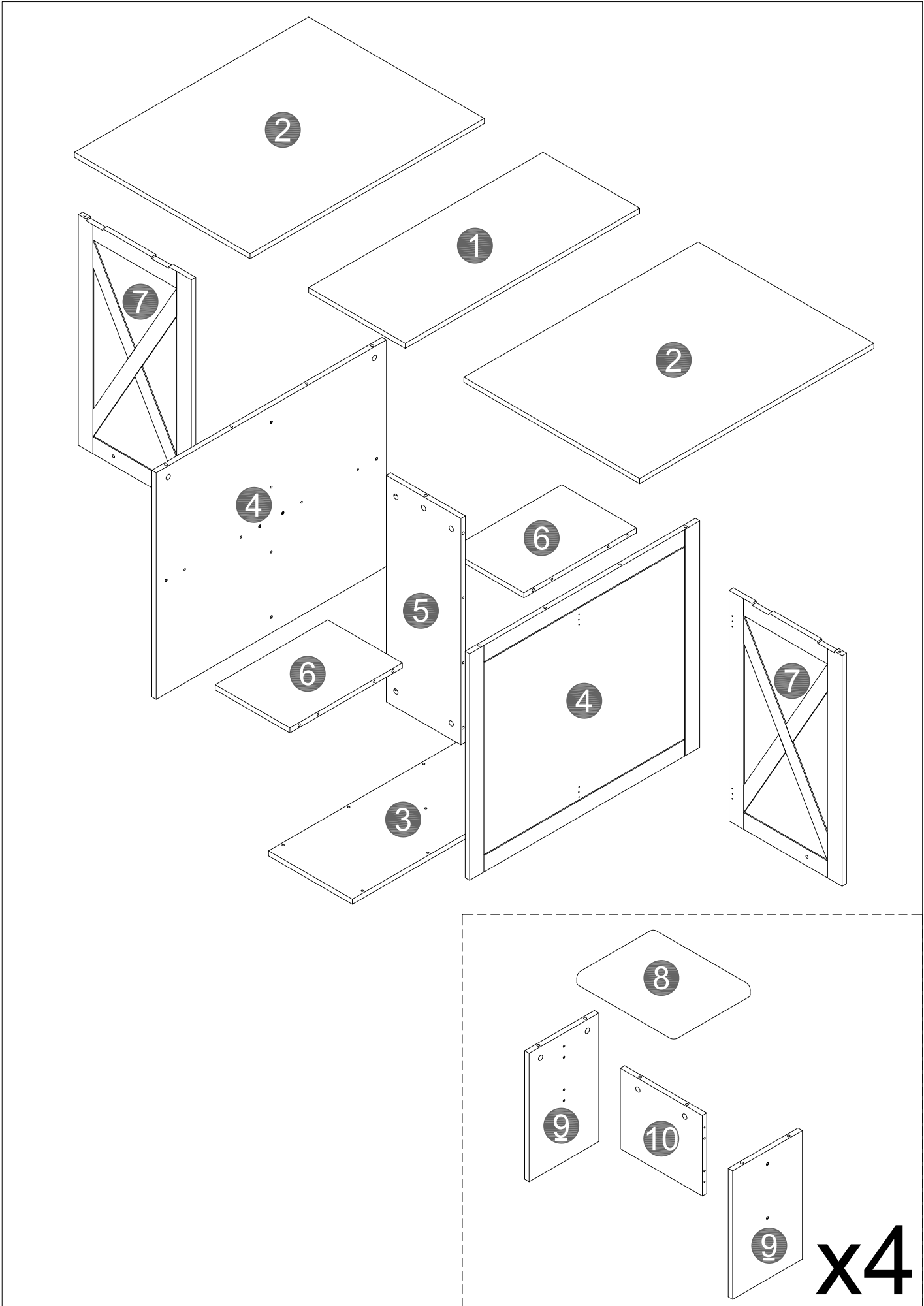

PARTS LIST

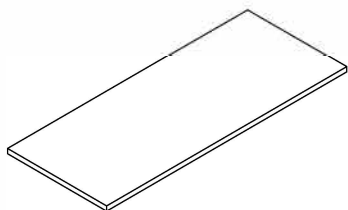

1 X1

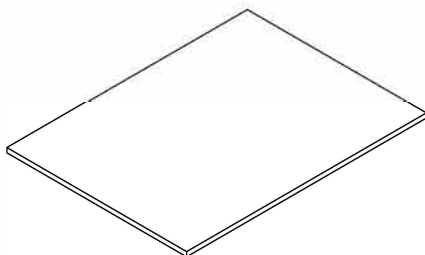

2 X2

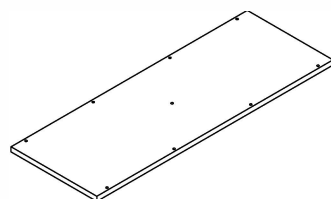

3 X1

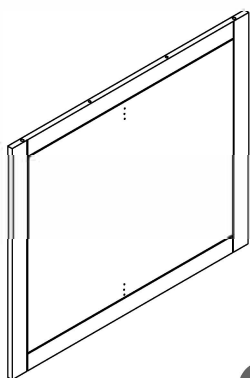

4 X2

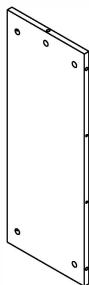

5 X1

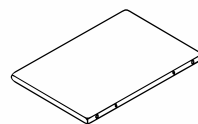

6 X2

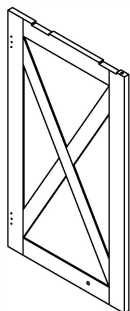

7 X2

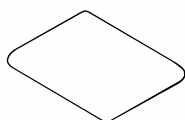

8 X4

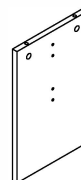

9 X8

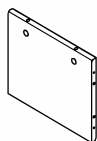

10 X4

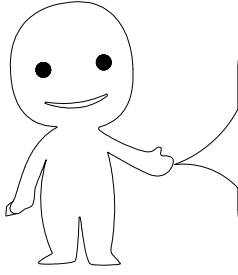

Please prepare the following tools

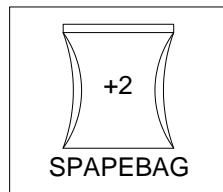
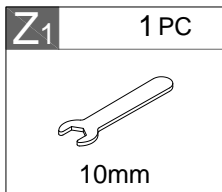
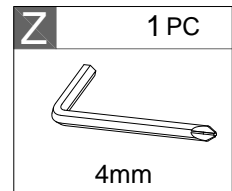
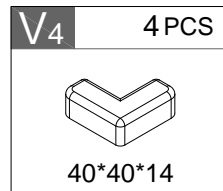
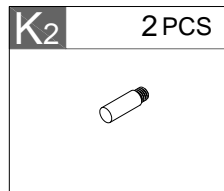
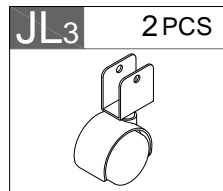
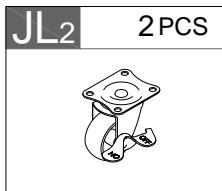
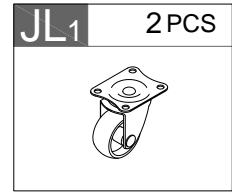
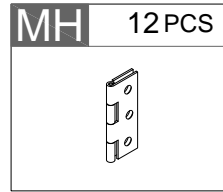
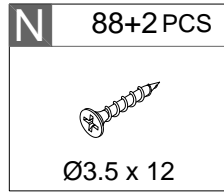
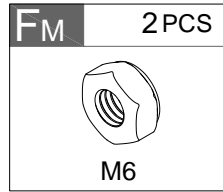
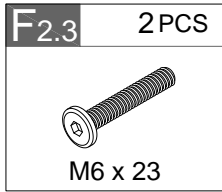
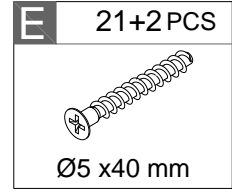
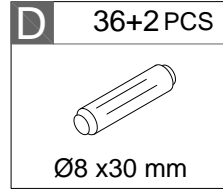
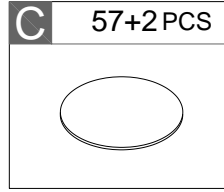
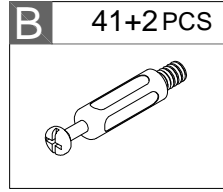
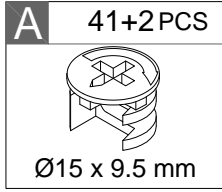
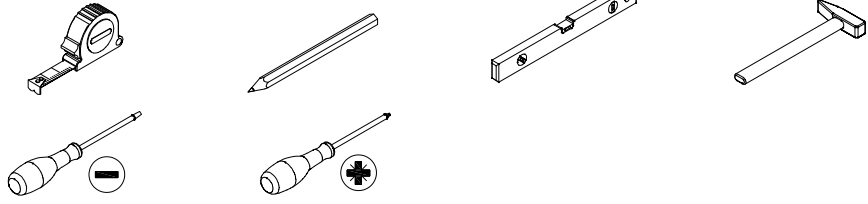

Tips: The number after "+" represents the spare hardware.

IMPORTANT NOTES:

The item you are purchasing is a large furniture product that requires a large number of components to assemble.

Please take all parts boxes out of the packaging and place them in order. So that you can follow the steps in the installation manual to find the corresponding parts box and quantity of need when installing. Please do not take too many parts to prevent the parts from scattering.

Please be patient and follow the instructions step by step for installation. If you have any problems during the installation process, you can ask our customer service to help you solve them!

SAFETY TIPS:

Static charge may cause dust on foam – clean with a dry or damp cloth. Small foam strands may be present – handle gently and dispose of properly. Do not burn or incinerate. Check local recycling guidelines.

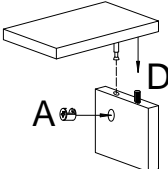
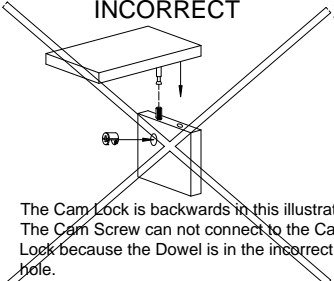
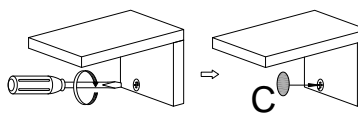
Cam Lock/Dowel Placement Supplement		
<p>CORRECT 1</p>  <p>When inserting the Cam lock, make sure that the open End of the cam Lock faces the Cam Screw Entry. The Dowel will be inserted in the hole NEXT to the Cam Lock/Cam Screw hole.</p>	<p>INCORRECT 2</p>  <p>The Cam Lock is backwards in this illustration. The Cam Screw can not connect to the Cam Lock because the Dowel is in the incorrect hole.</p>	<p>3</p>  <p>To tighten, turn the Cam Lock CLOCKWISE until the arrow or "Δ" signs point AWAY from the connected Panel and attach the same color label (C) to the hole.</p> <p>*NOTE: DO NOT USE AN AUTOMATIC SCREWDRIVER TO TIGHTEN CAM LOCKS, DO NOT OVER-TIGHTEN.</p>

1

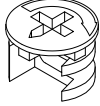
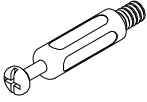
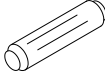
A	6 PCS	B	12 PCS	D	6 PCS
					

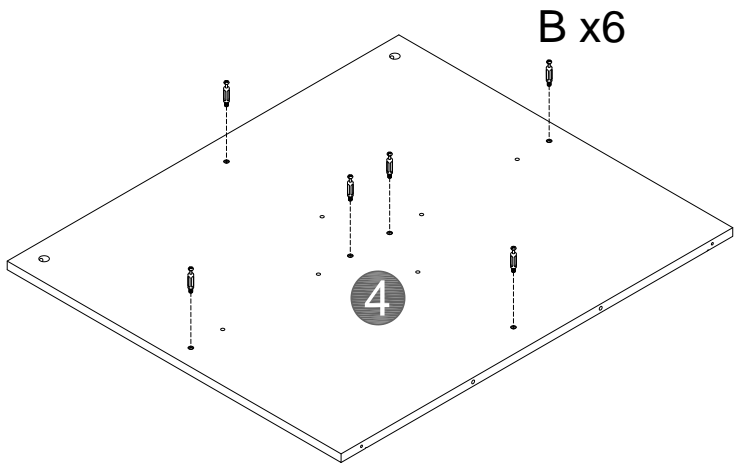
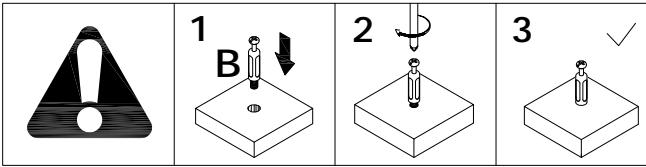

x2

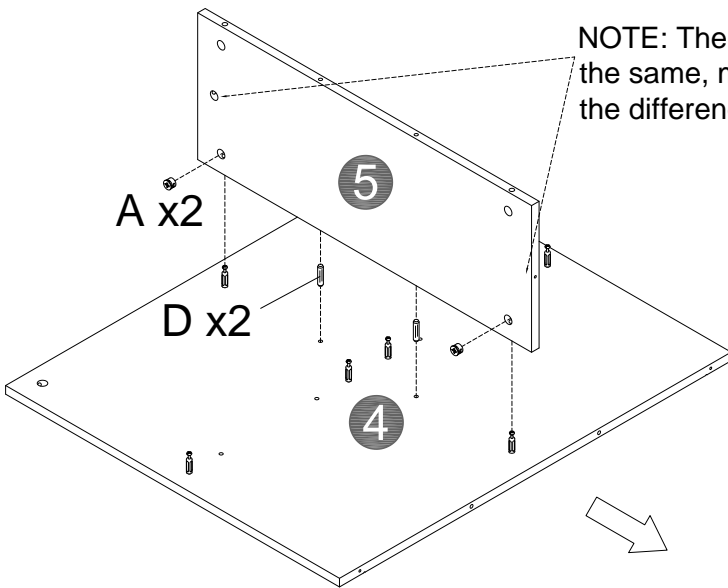

NOTE: The TOP & Bottom are not the same, make sure you had find the difference.

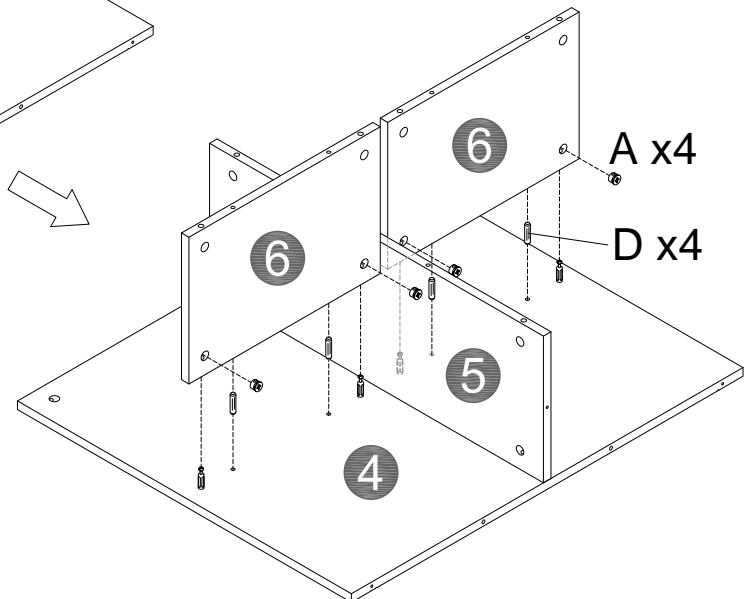

2

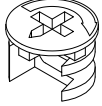
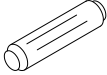
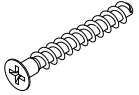
A	6 PCS	D	10 PCS	E	5 PCS
					

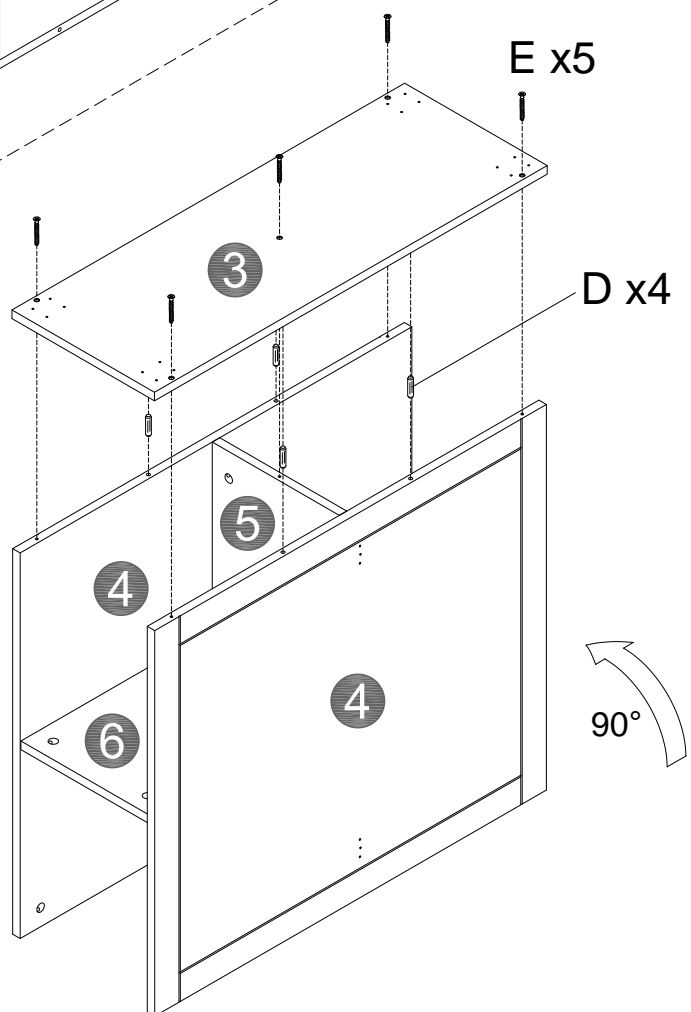
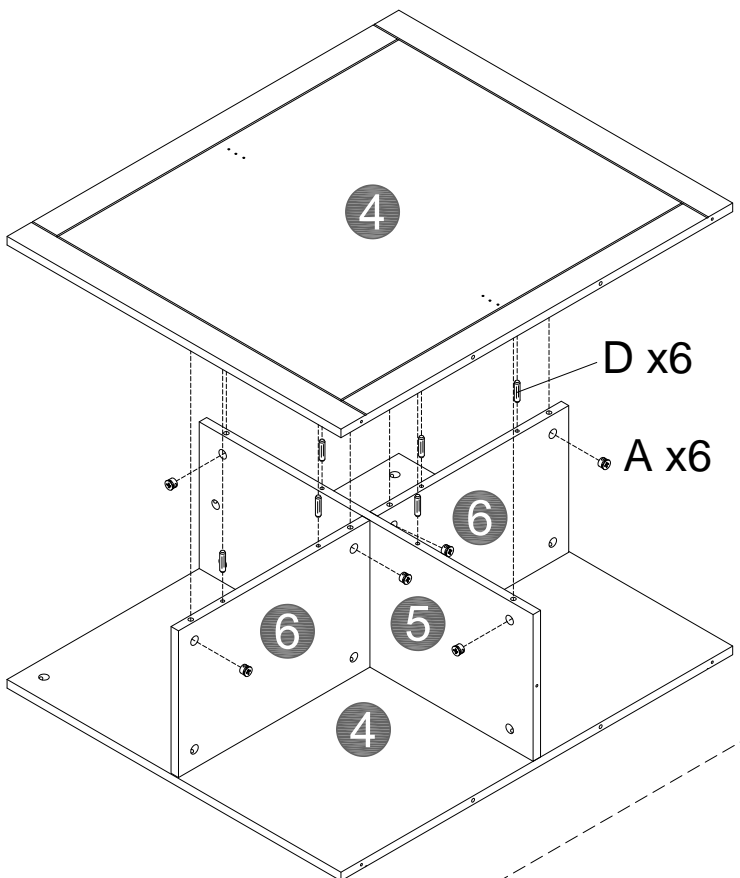

3

N	28 PCS	MH	4 PCS	JL1	2 PCS	JL2	2 PCS	JL3	2 PCS	F2.3	2 PCS
FM	2 PCS	Z	1 PC	Z1	1 PC						

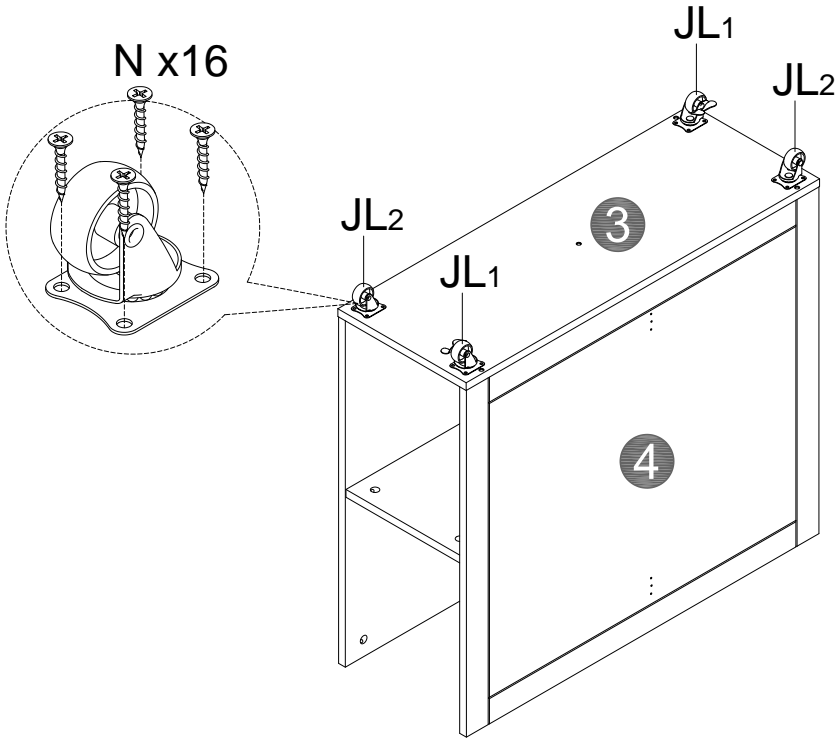

NOTE: Arrange the casters in the four corners of the panel so that the locking and non-locking casters are on opposite angles.

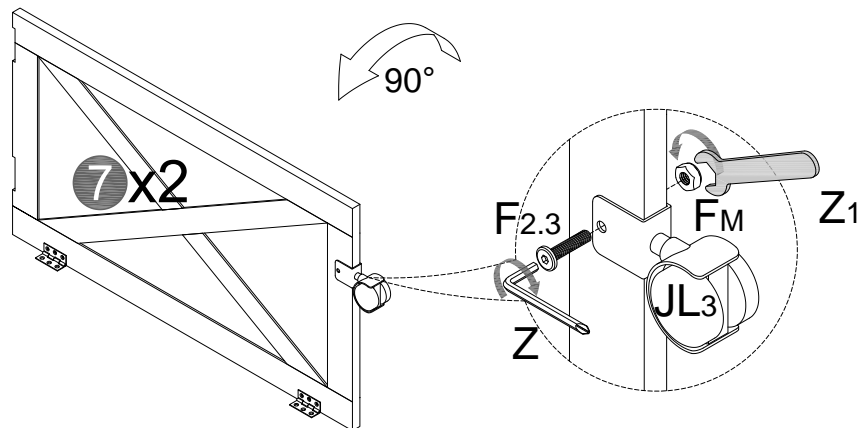
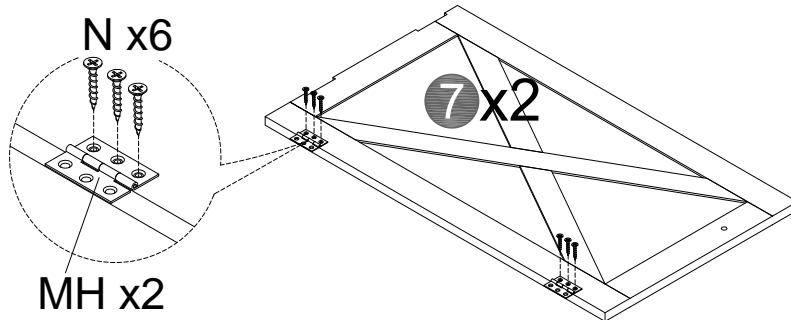

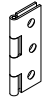

4

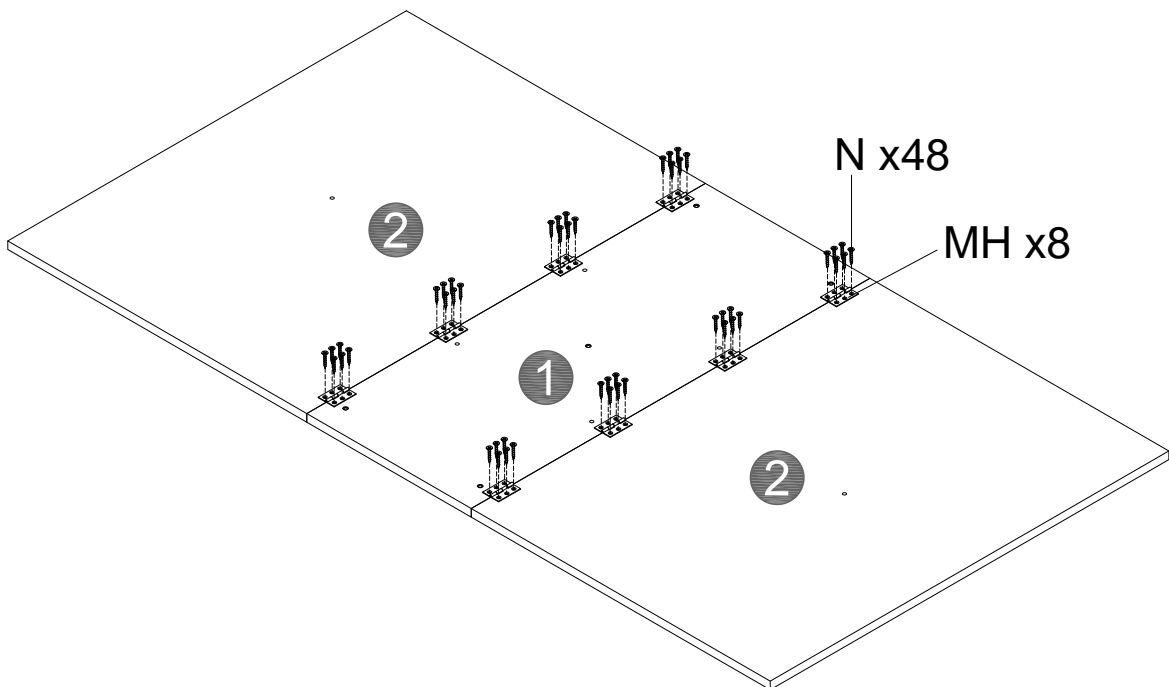
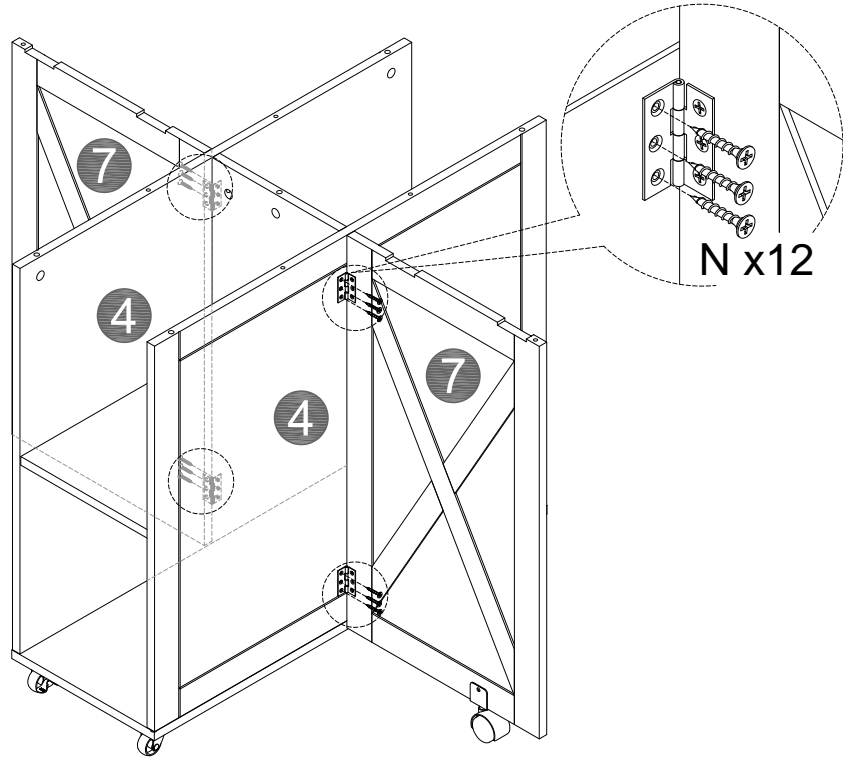
N	60 PCS	MH	8 PCS
			

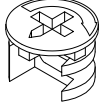
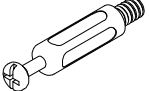
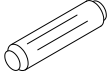

5

A	5 PCS	B	5 PCS	D	4 PCS	K₂	2 PCS
							

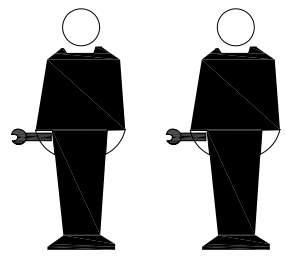
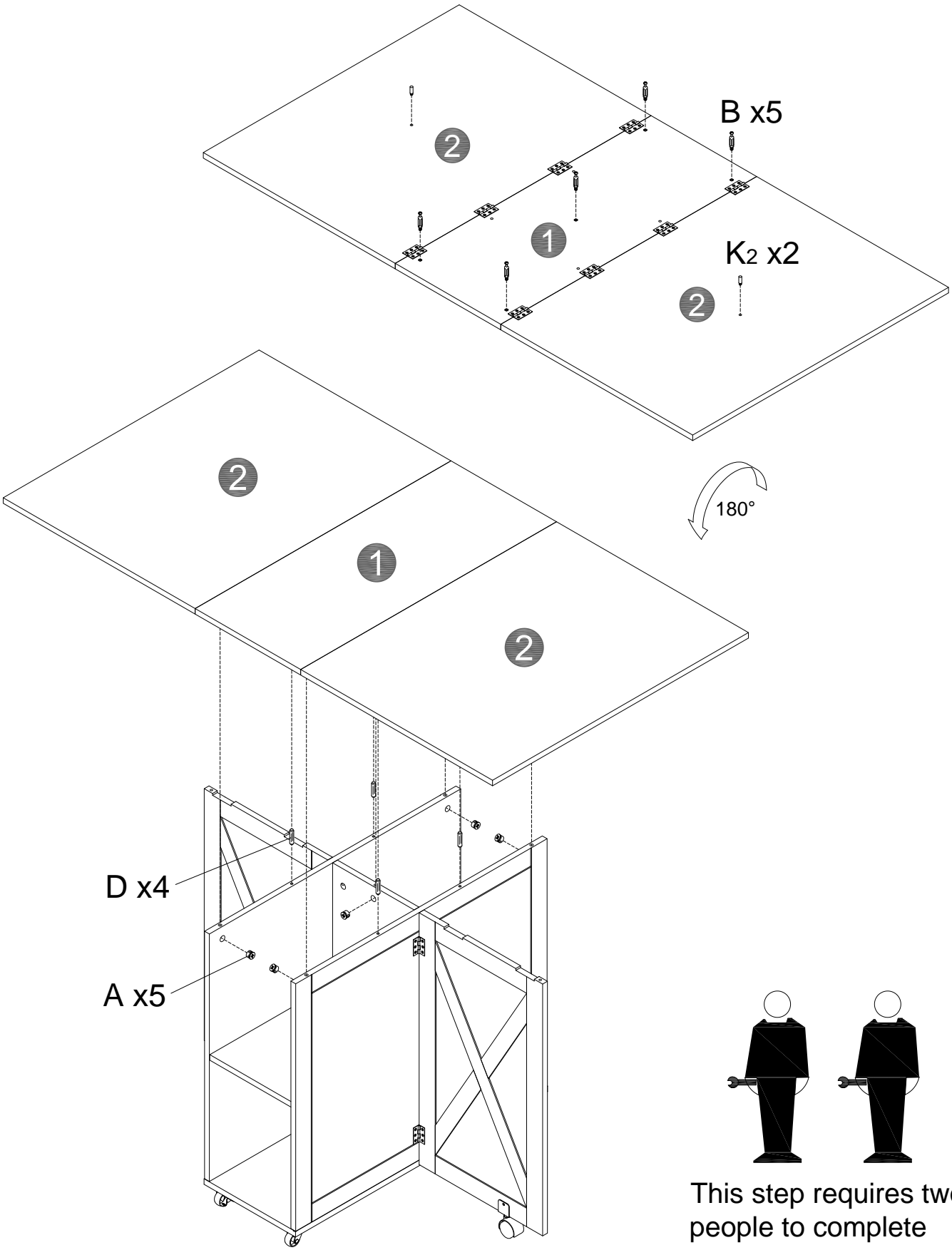

This step requires two people to complete



A	24 PCS	B	24 PCS	D	16 PCS	E	16 PCS

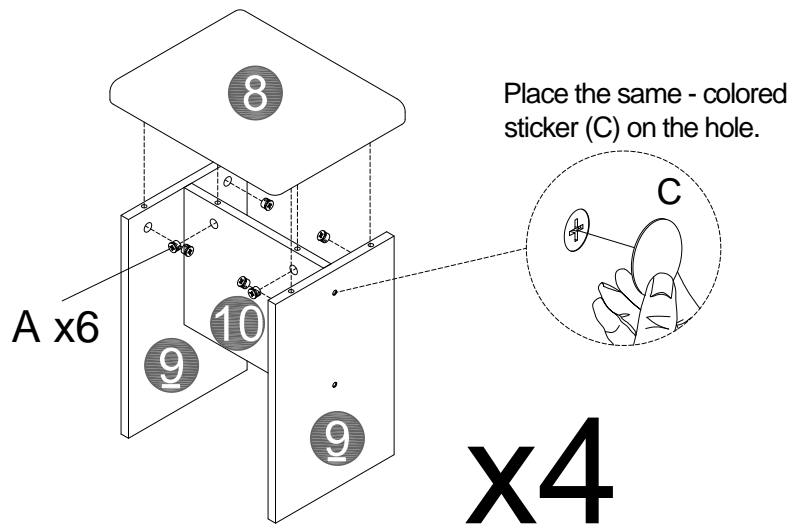
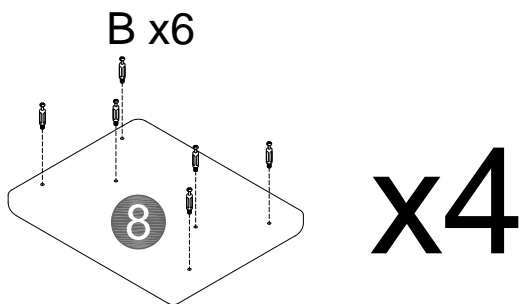
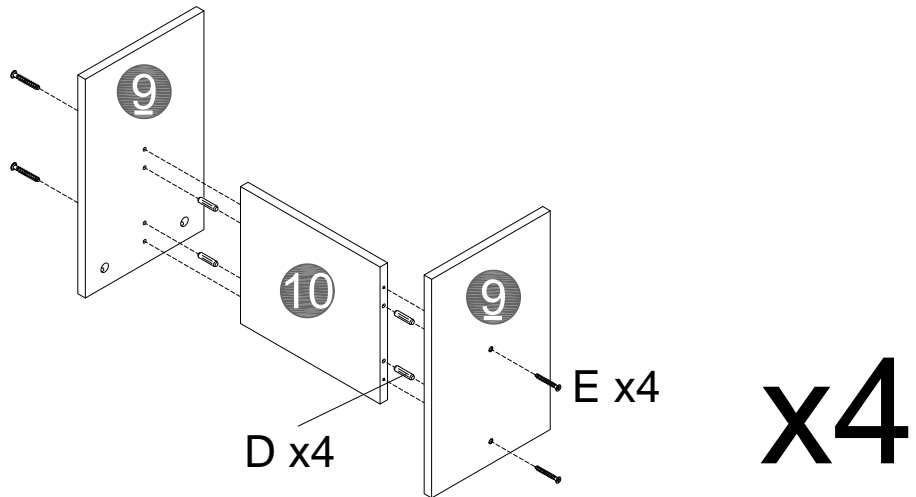

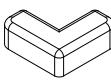

V ₄	4 PCS
	
40*40*14	

