

# Owner Manual

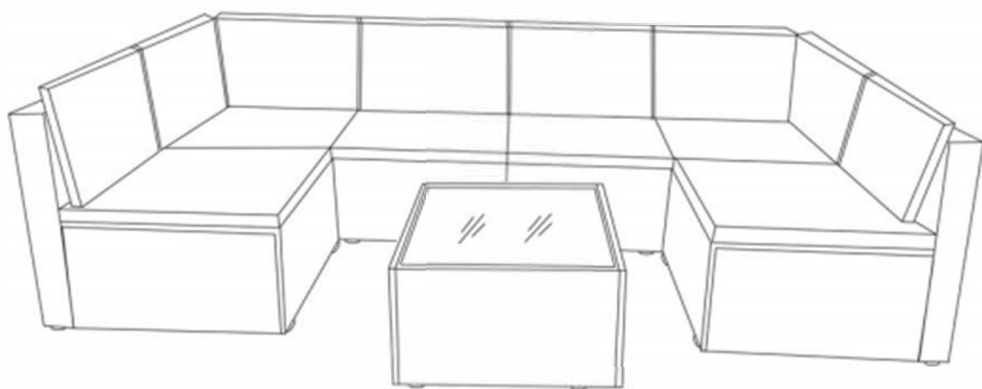

# WARRANTY

We strive to offer high quality product and we also try our best to satisfy each customer that order from us, no matter on products or services as needed. Each customer receives a record of their order, such as the order number or item receipt. For any items that are out of warranty period, you may still be able to purchase the replacement parts from our company if they are available.

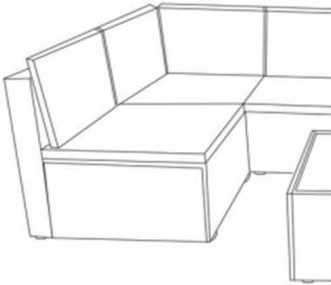

# MAINTENANCE AND WARNING

Please read the manual thoroughly  
before you start installing.

Please keep the product away from  
sharp object.

Packaging and small parts may have  
chocking hazard, please keep them away  
from children and pets.

Please clean the product according to each  
clean code, check the product description  
for more information.

Please keep the product away from  
fire.

If you have any other questions, please  
contact us, we will be glad to help you out.

If the product is placed under direct  
sunlight, the pattern or color might fade  
away overtime.

Check the product periodically to make  
sure everything is secured and tightened.

Always use proper tools for installation.

Do not jump on the product.



Two people



0-3

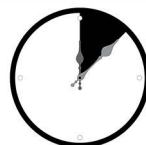

Around 55 min

# PRODUCT DESCRIPTION

Built with a reinforced wrought iron frame, this 7 piece sectional set ensures long lasting strength and stability.

The carefully crafted PE wicker exterior enhances both durability and elegance, making it perfect for outdoor use.

Designed with waterproof and UV resistant fabric, the cushions maintain their shape and color over time.

Each cushion features a zippered design, making cleaning and maintenance effortless.

With four armless chairs, two corner units, and a stylish coffee table, you can easily adjust the layout to fit your space.

# EXPLODED VIEW-1

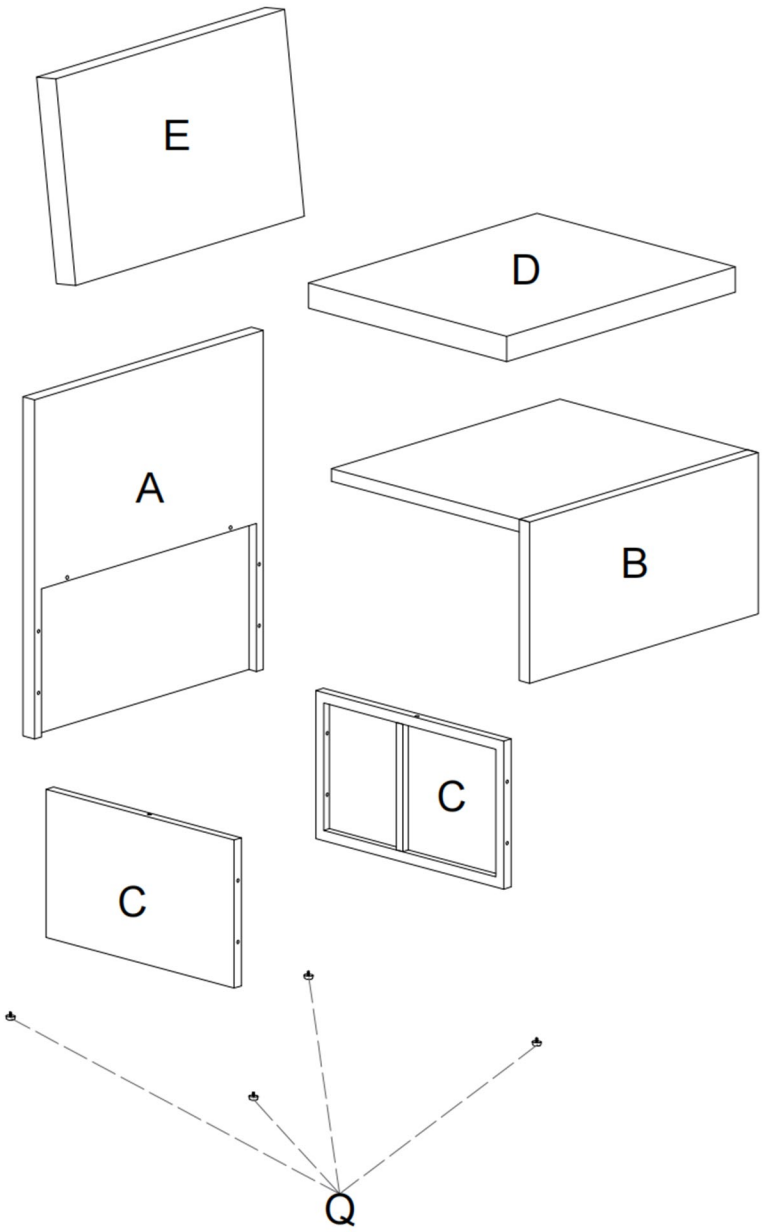

# PARTS

A\*4

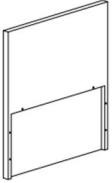

Backrest panel

B\*4

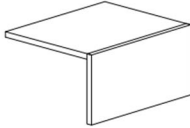

Seat frame

C\*10



Right frame

D\*6

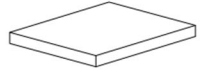

Seat cushion

E\*6

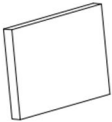

Back cushion

F\*2

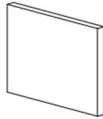

Armrest cushion

G\*1

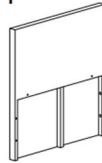

Backrest

H\*1

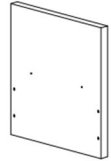

Armrest

I\*1

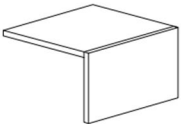

Seat frame

J\*1

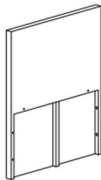

Backrest

K\*1

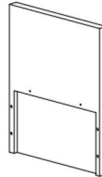

Right armrest

L\*1

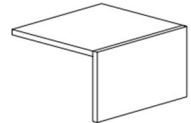

Seat frame

M\*1



Frame

N\*2

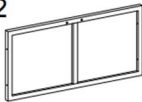

Boards

O\*2



Boards

P\*1



Glass Tabletop

Q\*28



Adjustable legs

# HARDWARE

## TOOL LIST

NOTE: Designated with (★) We provide additional spare parts in the hardware package

①\*82

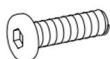

★ Bolt  
M6\*35mm

②\*84



★ Flat washer

③\*1



Allen key

④\*2

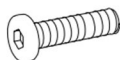

Bolt  
M6\*40mm

⑥\*10



Plastic Hooks

Please make sure all hardware&packing material fitting the list.  
Especially some small accessories may be missing during transportation. Please contact us if you have any question.

# step 1

Please prepare the corresponding parts for the specific product.

A\*1

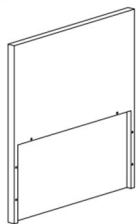

Backrest panel

B\*1

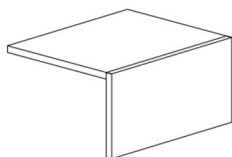

Seat frame

C\*2

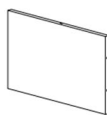

Right frame

D\*1

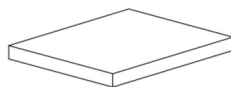

Seat cushion

E\*1

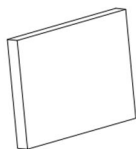

Back cushion

Q\*4



Adjustable legs

①\*12



Bolt  
M6\*35mm

②\*12



Flat washer

③\*1



Allen key

# step 2

Place the Backrest Panel (A) flat on a protected surface. Align the pre-drilled holes on the Seat Frame (B) with corresponding holes on the Backrest. Insert bolts through both components, secure with flat washers, and tighten gradually using the provided allen wrench.

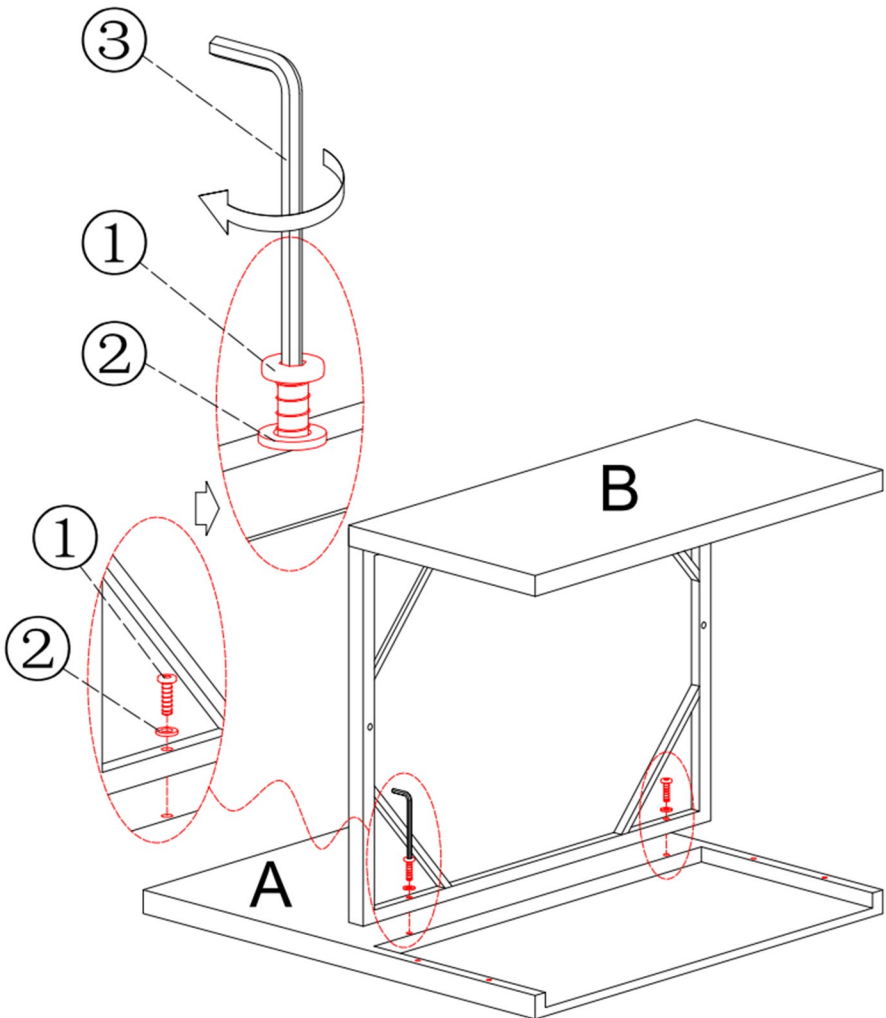

# step 3

Attach the Right Frame (C) to the assembly from Step 2. Ensure the connection points on both the Seat Frame and Backrest are aligned. Place a flat washer on each bolt, then tighten evenly with the allen wrench.

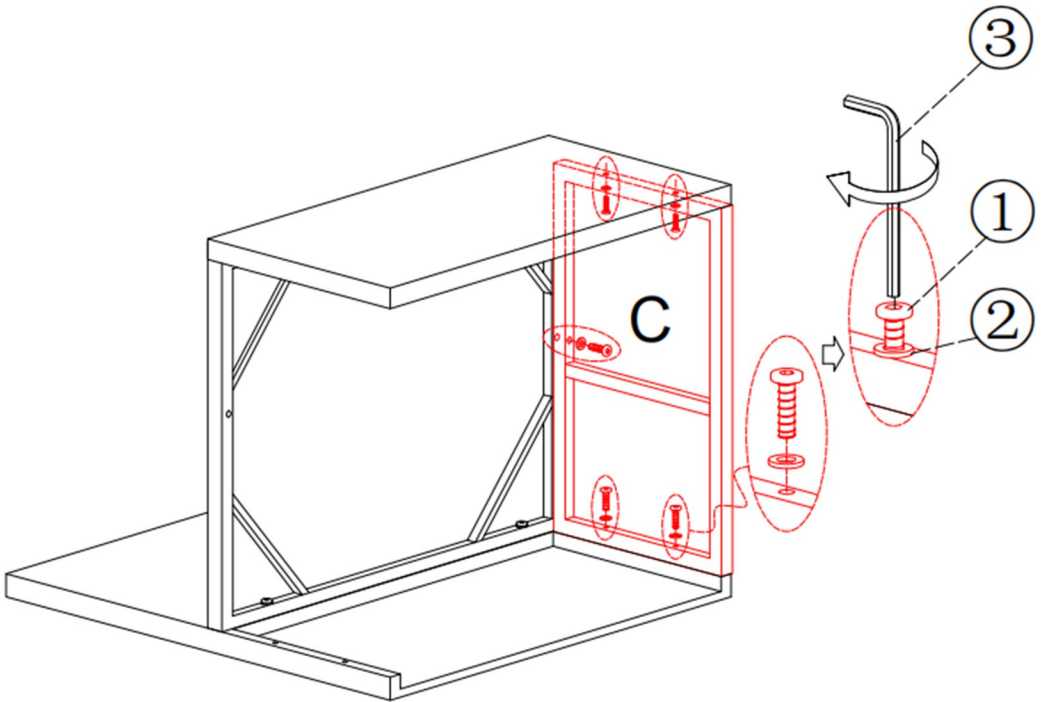

# step 4

Repeat Step 3 for the Left Frame (C). Then, screw all four adjustable legs into the corners of the Seat Frame by hand.

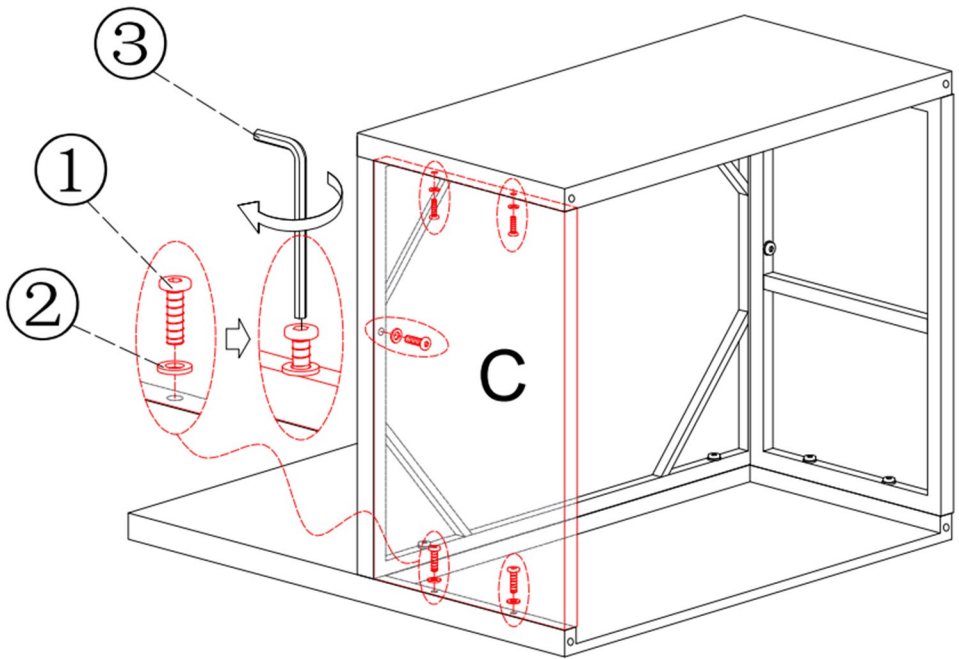

# step 5

Then, screw all four adjustable legs (Q) into the corners of the Seat Frame by hand.

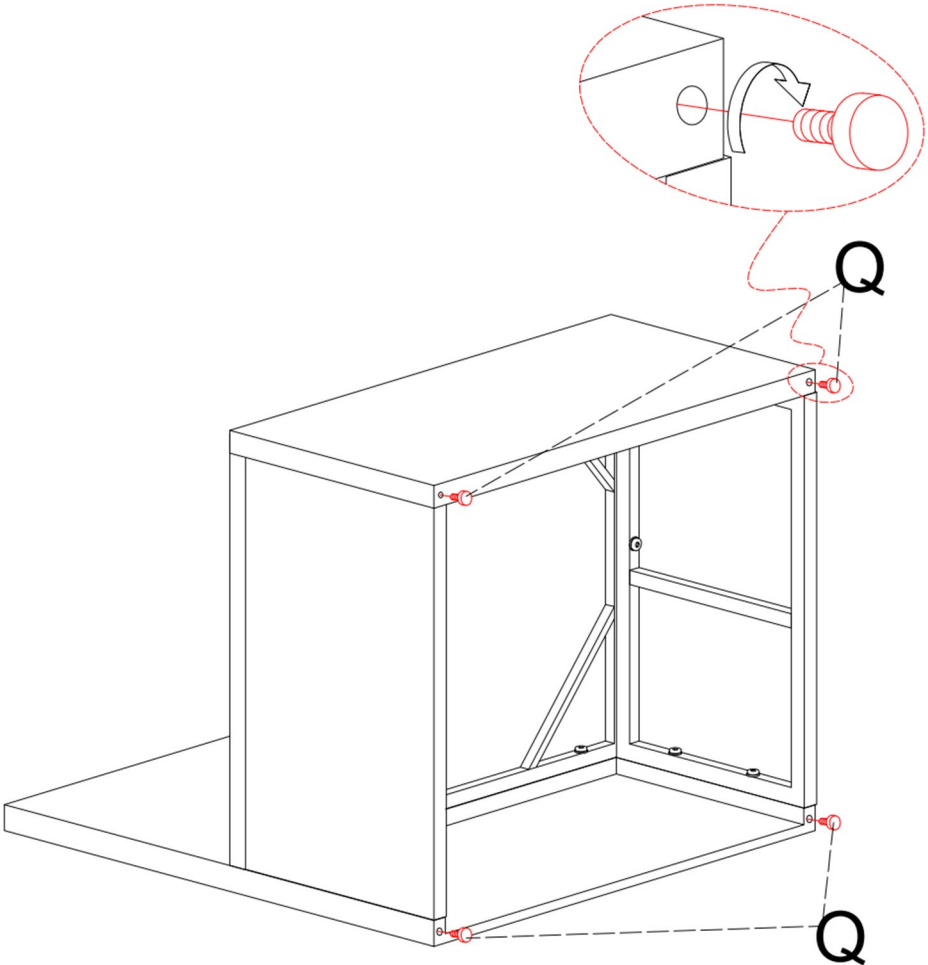

# step 6

Position the Seat Cushion (D) and Back Cushion (E) onto the frame.

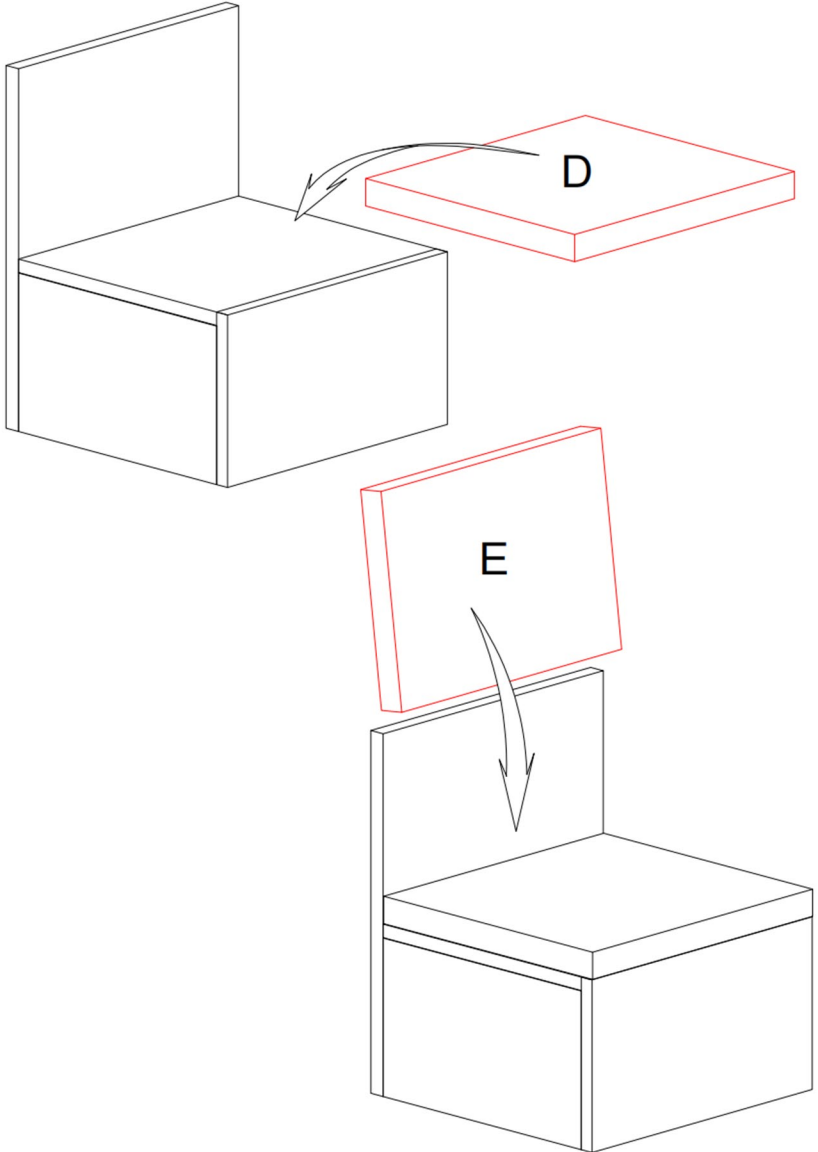

# EXPLODED VIEW-2



The product's left and right are determined by sitting posture

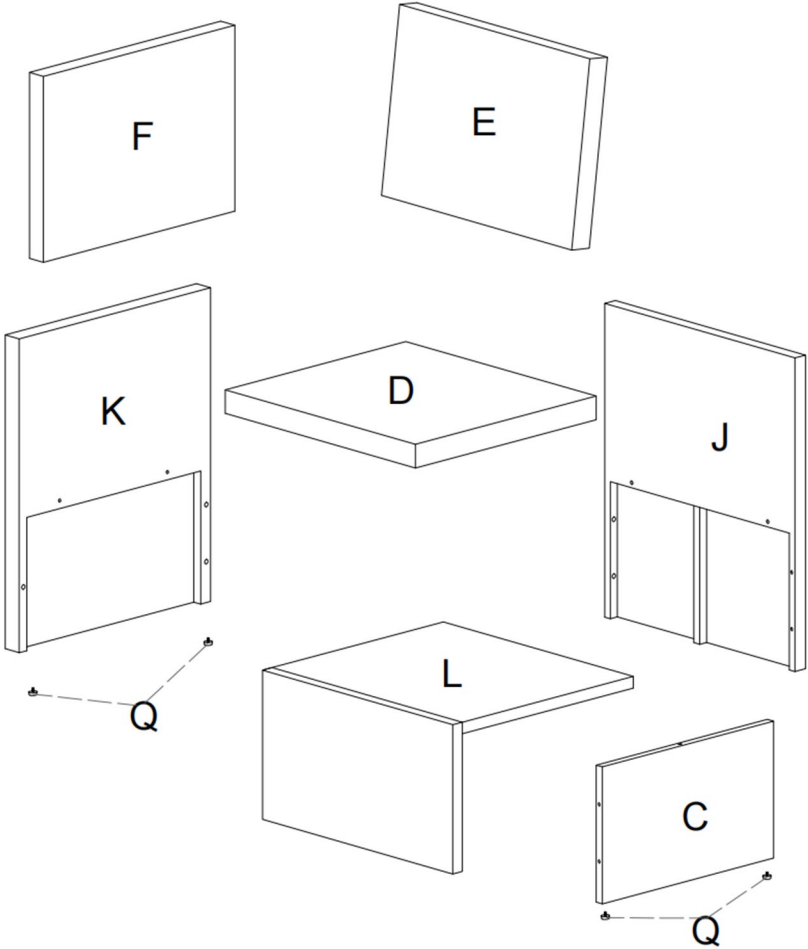

# step 8

Please prepare the corresponding parts for the specific product.

J\*1

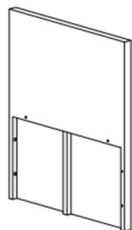

Backrest panel-right

K\*1

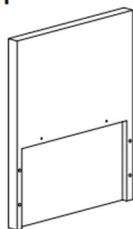

Armrest-right

L\*1

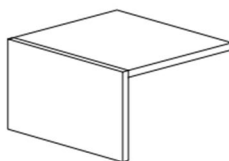

Seat frame-right

C\*1

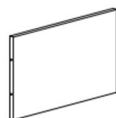

Right frame

D\*1

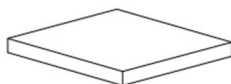

Seat cushion

E\*1

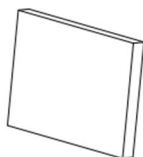

Back cushion

F\*1

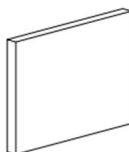

Arm cushion

Q\*4



Adjustable legs

①\*11



Bolt  
M6\*35mm

②\*12



Flat washer

③\*1



Allen key

④\*1



Bolt  
M6\*40mm

# step 9

Place the Backrest Panel (J) flat on a protected surface. Align the pre-drilled holes on the Seat Frame (L) with corresponding holes on the Backrest. Insert bolts (1) through both components, secure with flat washers (2), and tighten gradually using the provided allen wrench(3).

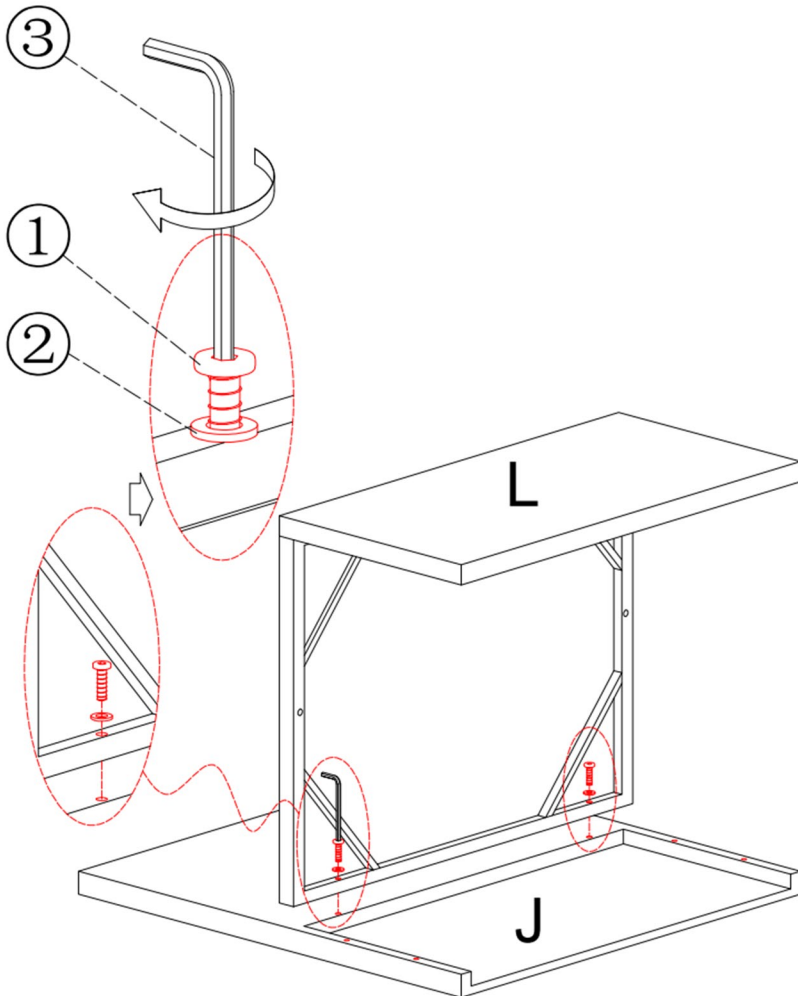



# step 11

Align the pre-drilled holes on Frame C with the assembly, tighten bolts (1) with flat washers (2).

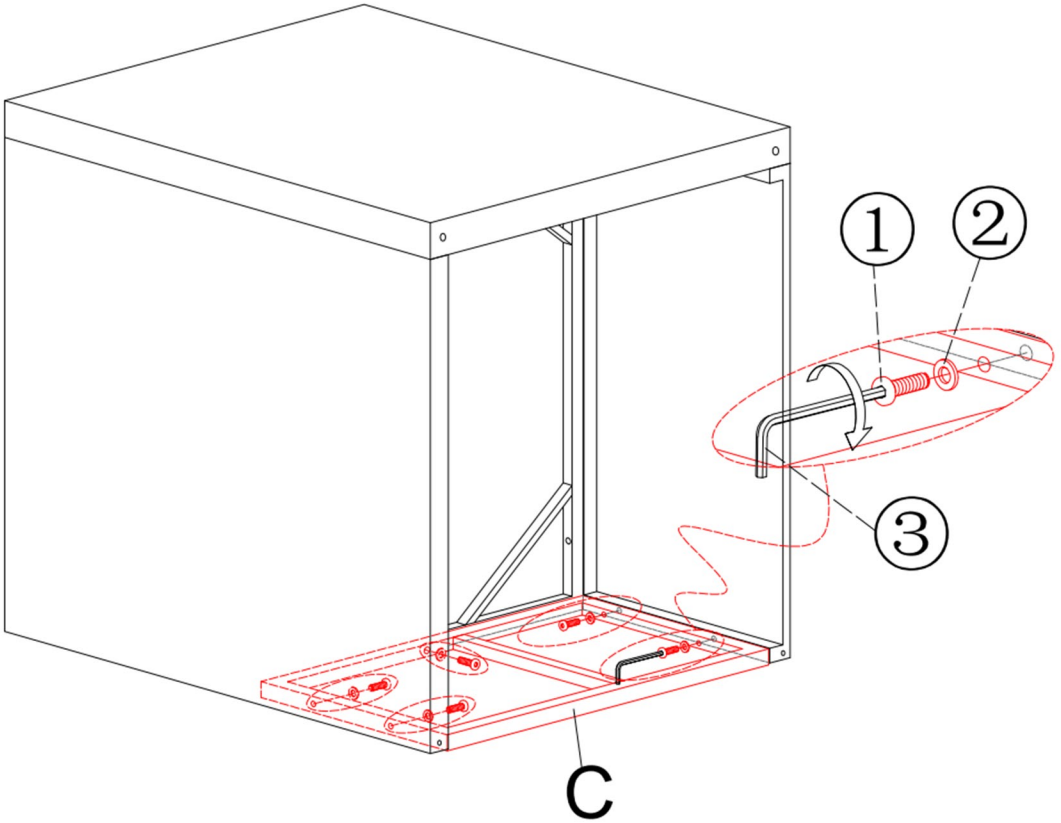

# step 12

Then, screw all four adjustable legs into the corners of the Seat Frame by hand.



# step 13

Position Seat Cushion (D), Back Cushion (E) onto the frame.

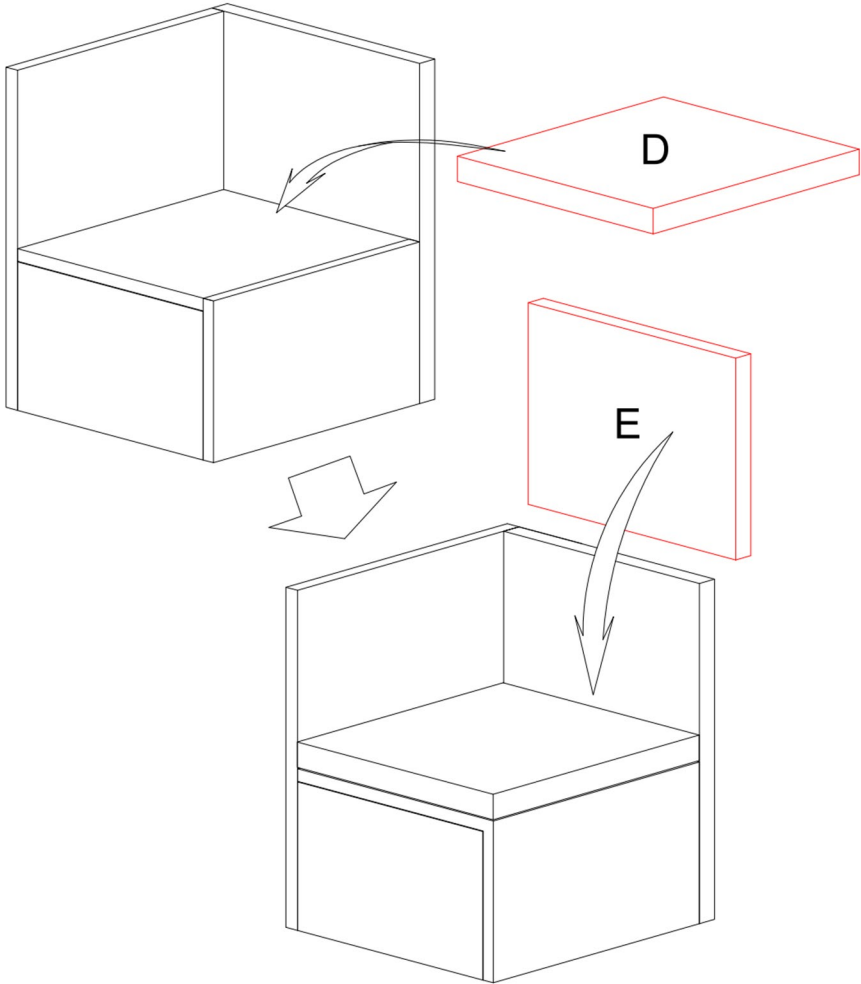

# step 14

Position Armrest Pillow (F) onto the frame.

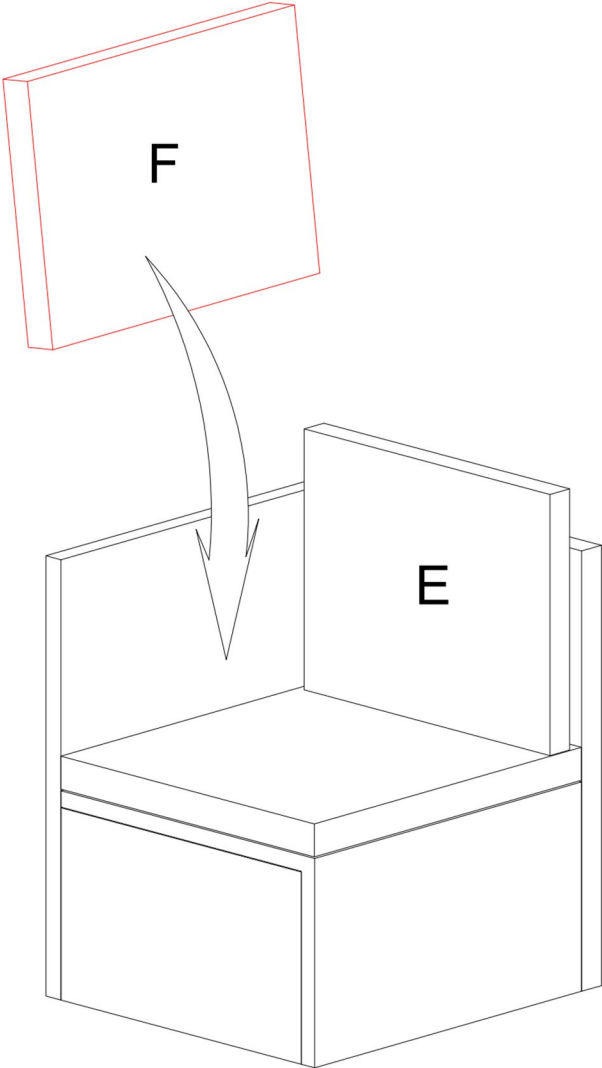

# EXPLODED VIEW-3

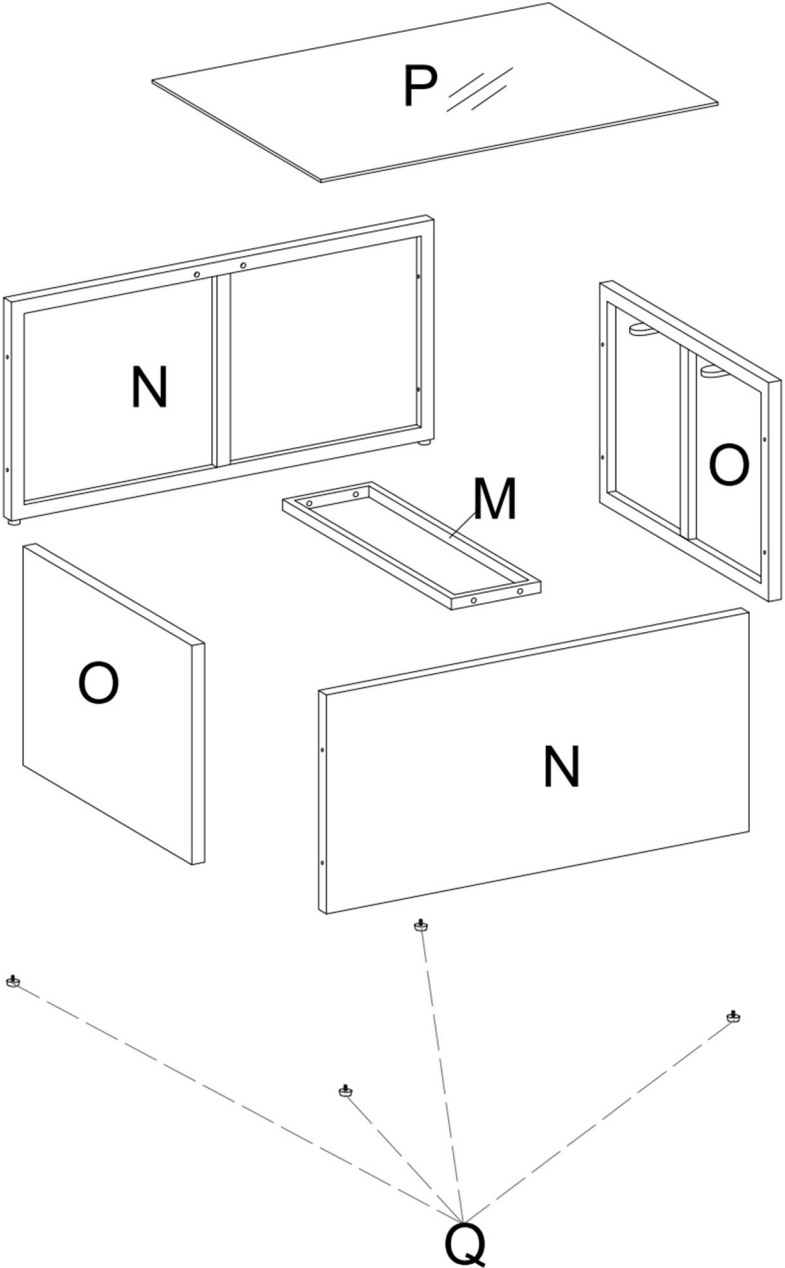

# step 16

Please prepare the corresponding parts for the specific product.

M\*1



Frame

N\*1

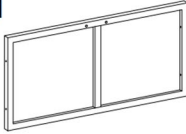

Boards

O\*2



Boards

P\*1



Glass Tabletop

Q\*4



Adjustable legs

①\*12



Bolt  
M6\*35mm

②\*12



Flat washer

③\*1



Allen key

# step 17

Align Boards (O) and (N): Connect one Board (O) with two Boards (N) as shown, ensuring internal pre-drilled holes align precisely. Insert bolts through holes from inside, add flat washers, and tighten all bolts securely.

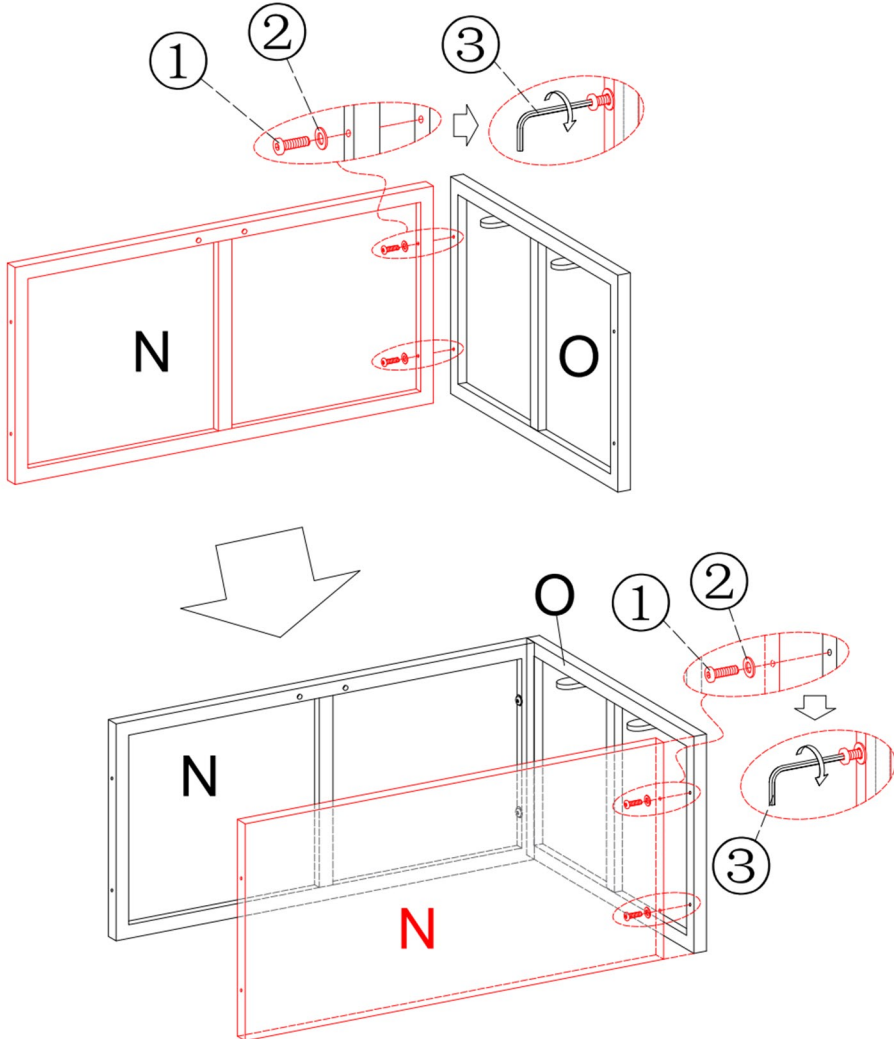

# step 18

Install the other Board (O) to the Boards (N) as shown, and align the internal pre-drilled holes. Add one flat washer (2) and insert bolts (1) through holes from inside, then tighten all bolts with the allen wrench (3) provided.

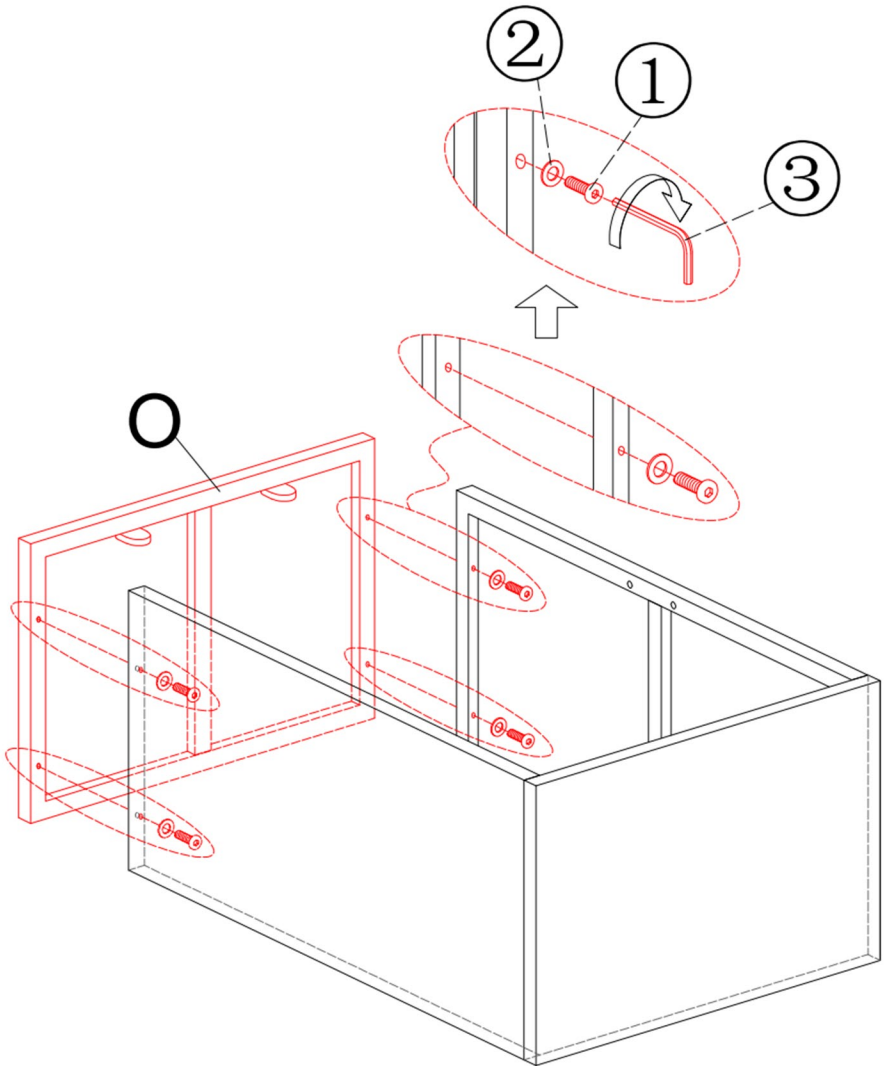

# step 19

Mount Frame (M): Place Frame (M) onto the assembled Boards (N). Align all pre-drilled holes, insert bolts with flat washers, and tighten all bolts with allen wrench provided.

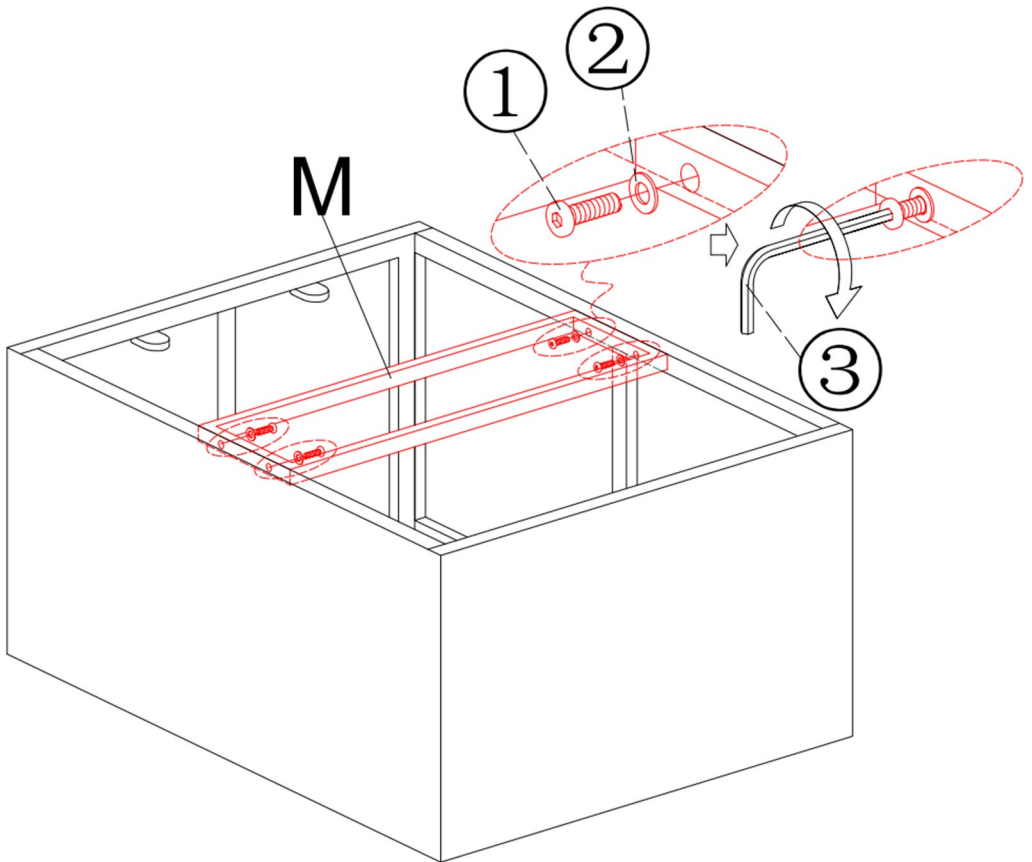

# step 20

Twist all four adjustable legs (Q) into each corner of the frame as shown. Stand the Table upright as shown, and place the Glass Tabletop (P) onto the frame carefully.

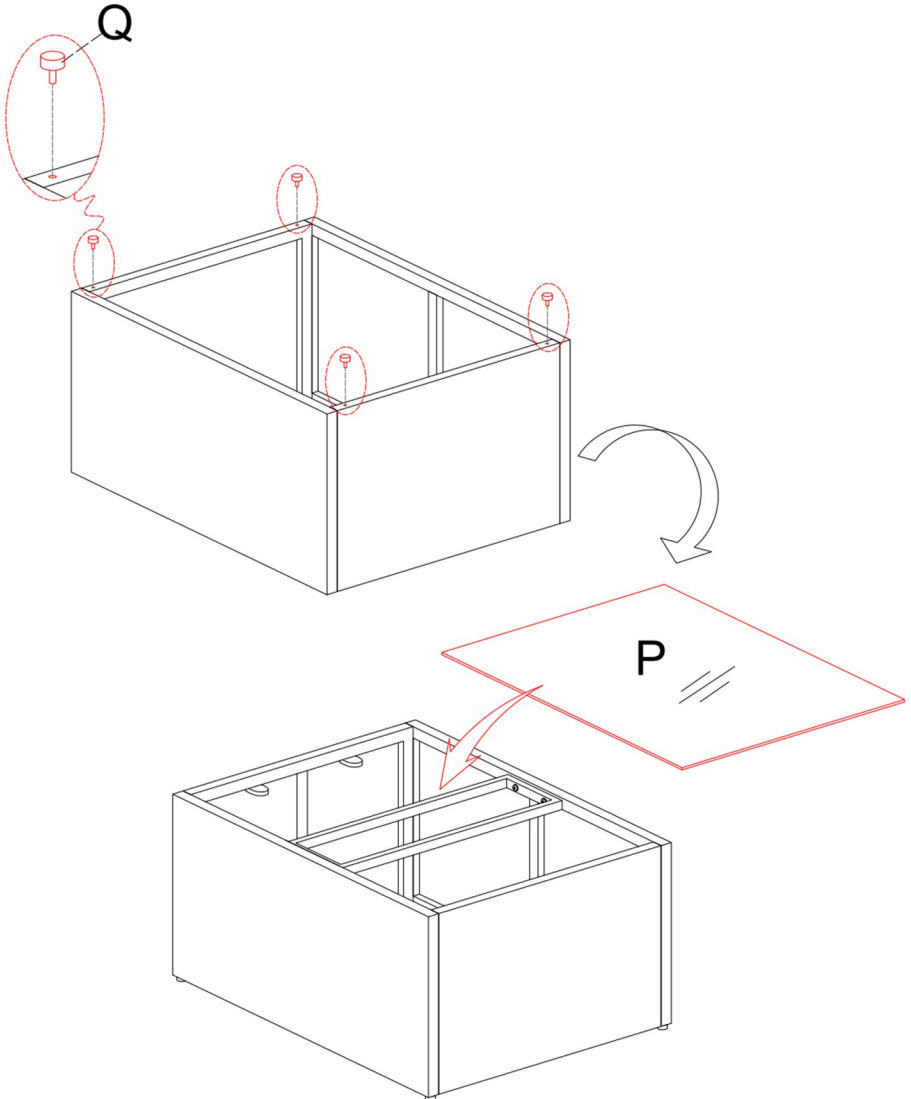

# EXPLODED VIEW-4



The product's left and right are determined by sitting posture

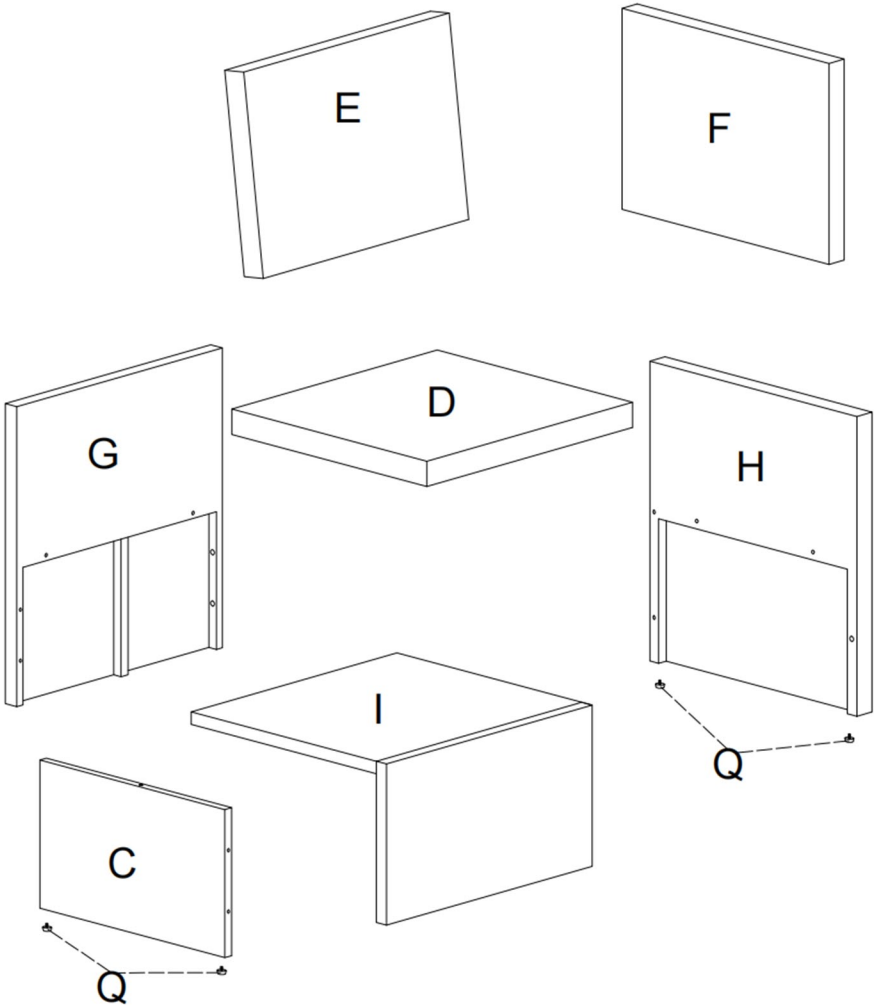

# step 22

G\*1

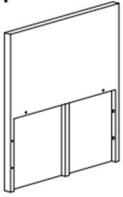

Backrest-left

H\*1

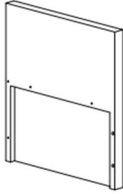

Armrest-left

I\*1

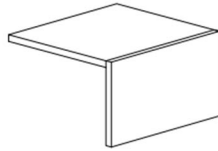

Seat frame

C\*1



left frame

D\*1

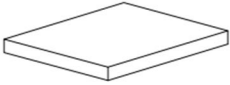

Seat cushion

E\*1

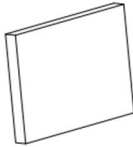

Back cushion

F\*1

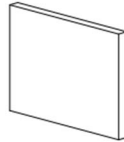

Arm cushion

Q\*4



Adjustable legs

①\*11



Bolt  
M6\*35mm

②\*12



Flat washer

③\*1



Allen key

④\*1



Bolt  
M6\*40mm

# step 23

Place the Backrest Panel (G) flat on a protected surface. Align the pre-drilled holes on the Seat Frame (I) with corresponding holes on the Backrest. Insert bolts through both components, secure with flat washers, and tighten gradually using the provided allen wrench.

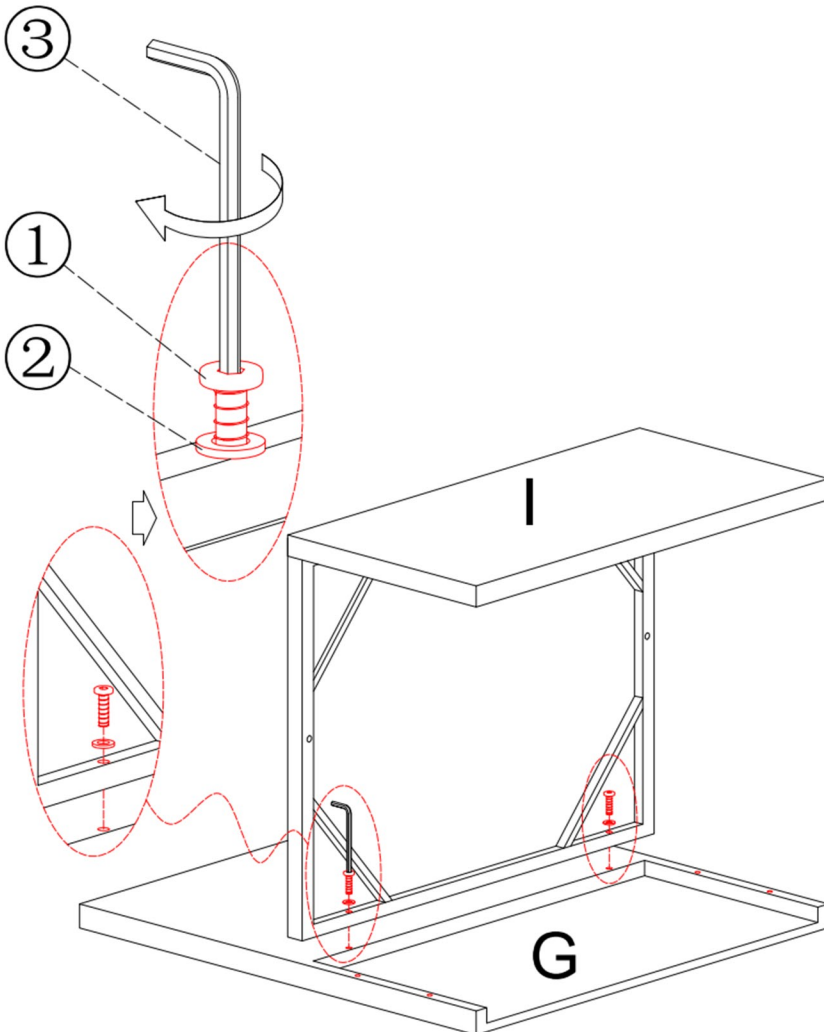

# step 24

Attach Right Armrest (H) to the assembly from Step 23. Place flat washers (2) on all bolts(1). First tighten Bolt (1) to secure the main frame connection, then tighten Bolt (4) at the corner joint.

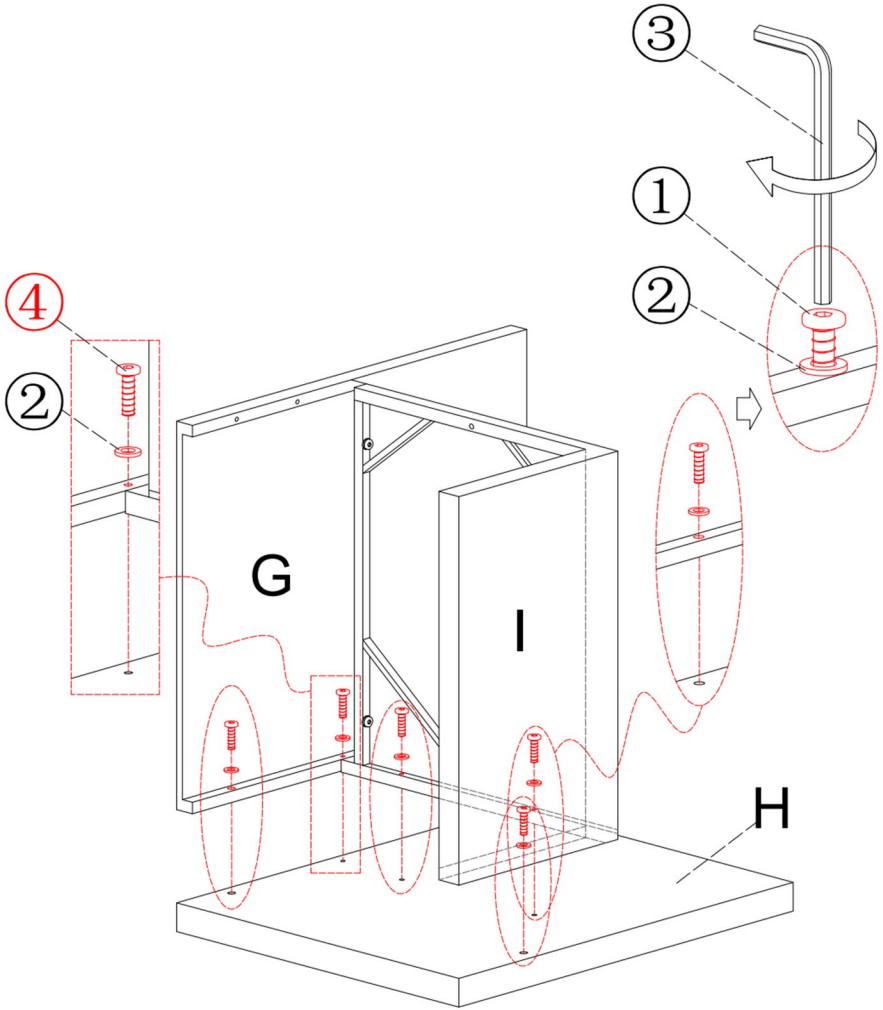

# step 25

Align the pre-drilled holes on Frame C with the assembly, tighten bolts (1) with flat washers (2).

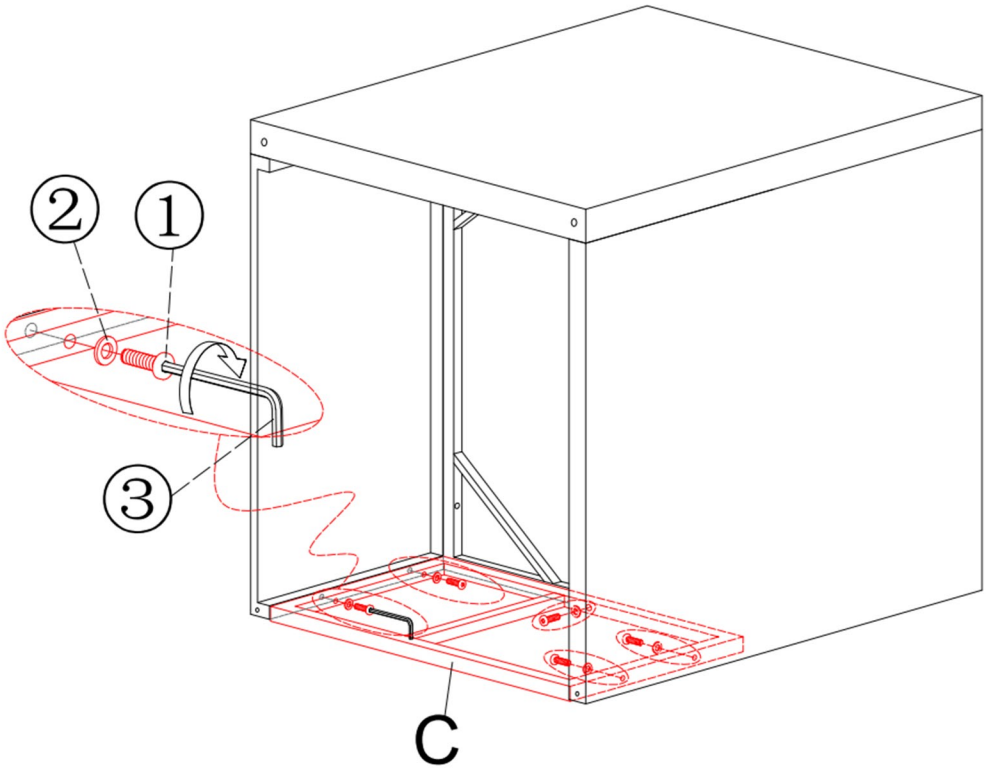

# step 26

Then, screw all four adjustable legs (Q) into the corners of the Seat Frame by hand.

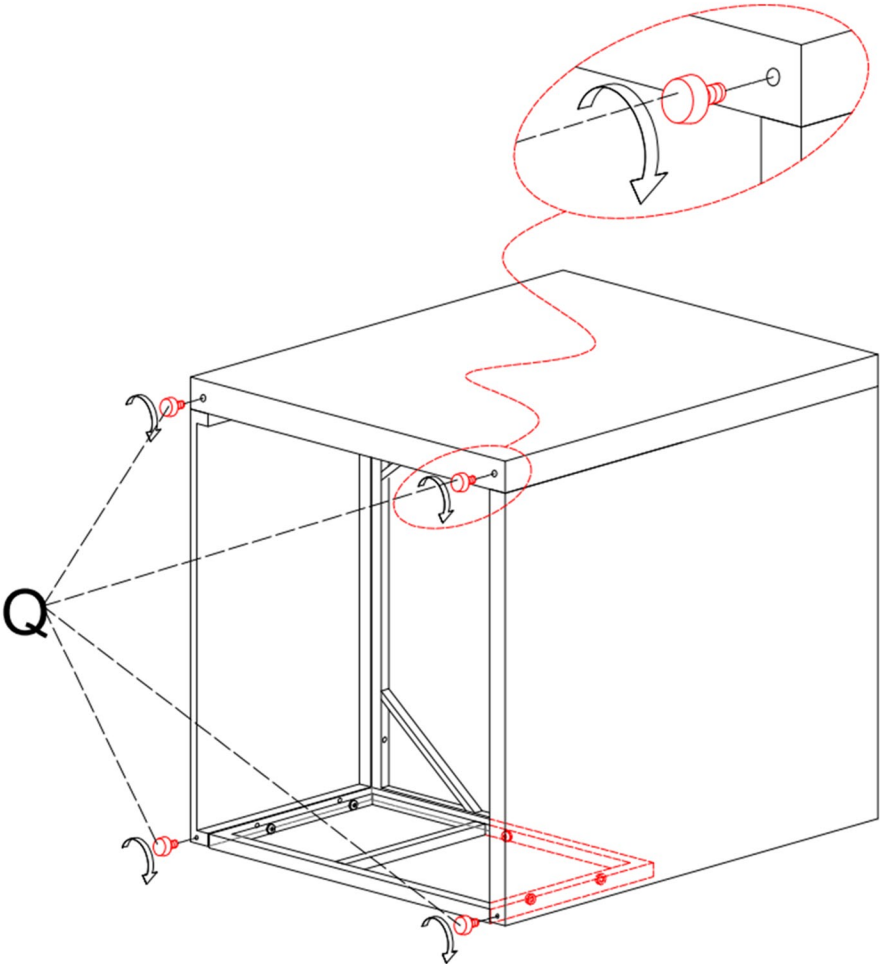

# step 27

Position the Seat Cushion (D) onto the frame.

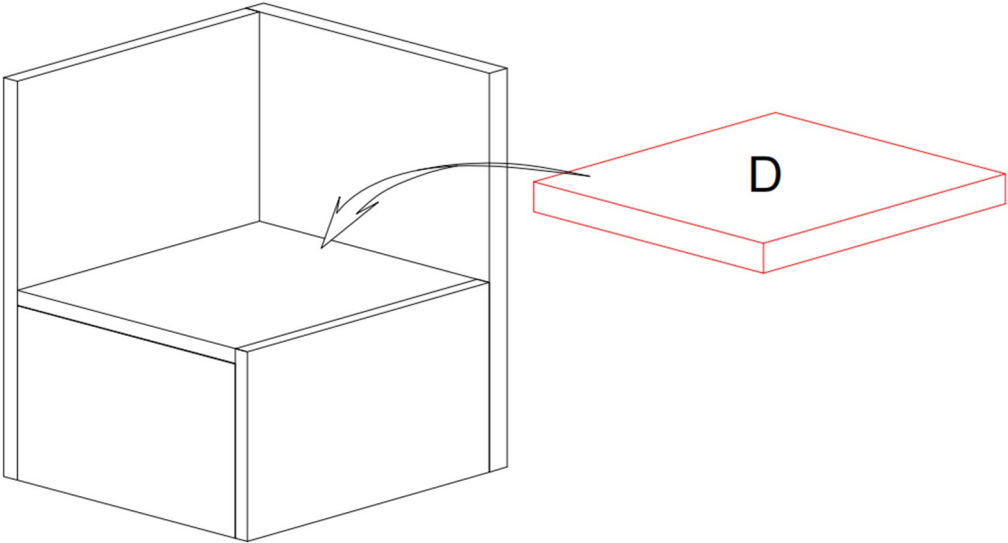

# step 28

Position the Back Cushion (E) onto the frame.

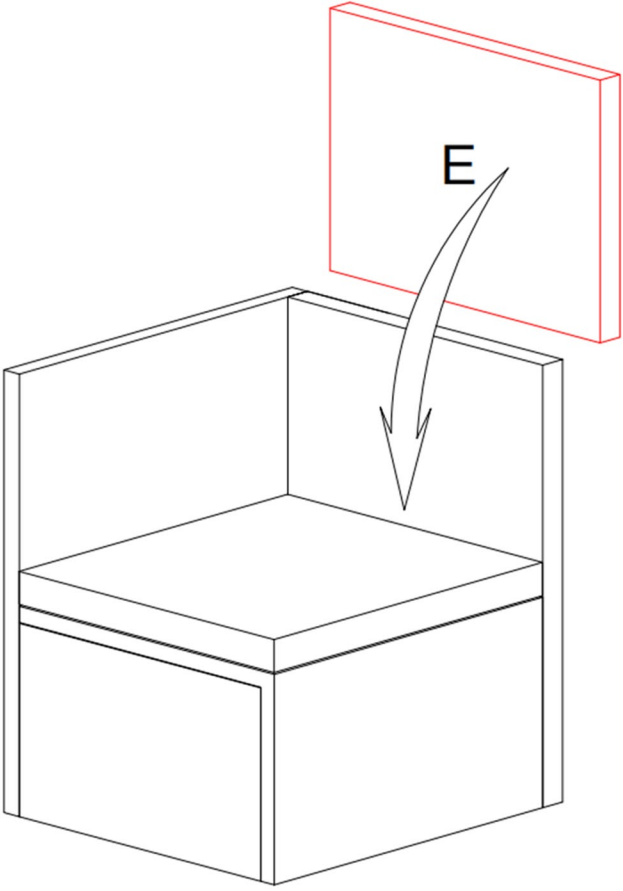

# step 29

Position the armrest cushion (F) onto the frame.

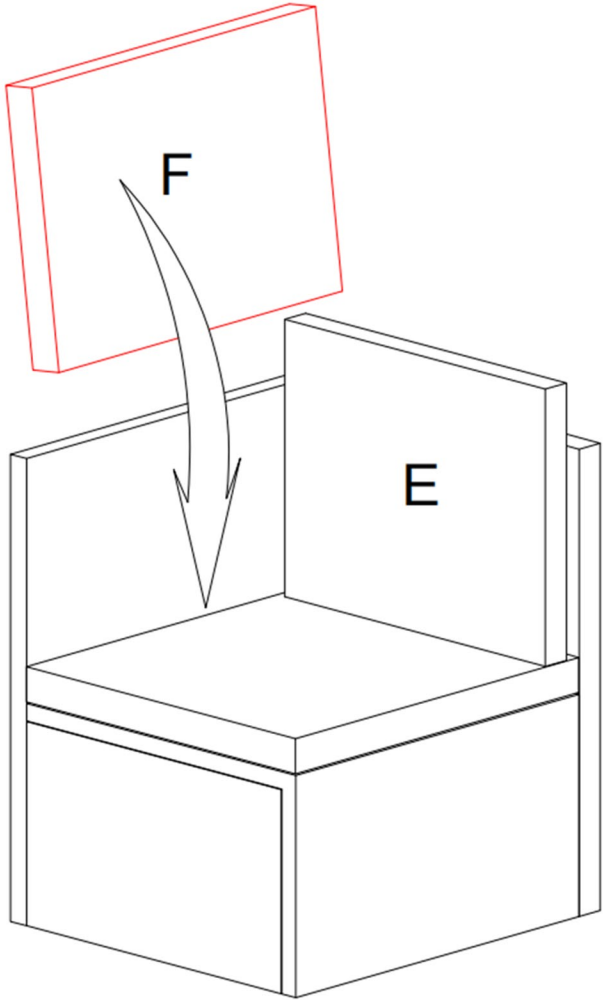

# step 30

The plastic hooks inside the package are used to fix the chairs together, simply clip the connectors onto the edge of the chair frames as shown.

