

TV Stand

assembly guide

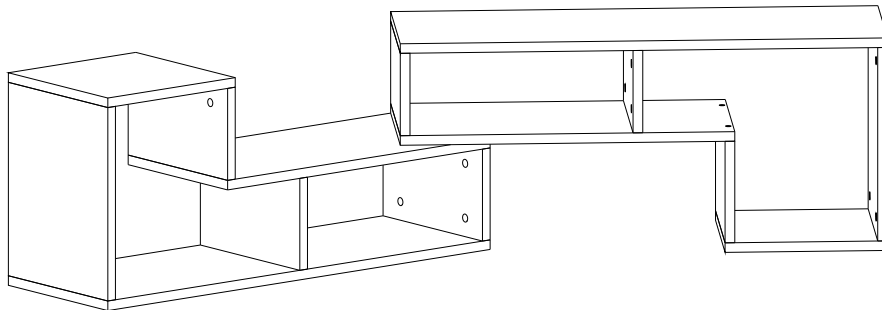

introduction



Before starting, please check all components and accessories according to the provided list. If you purchased more than one product, to prevent confusion, be sure that you completed the first product, then start the next one. Please make sure that you select correct numbered part and use specific connector to assemble. We do not recommend any modification or rotation in assembly. Please follow the manual carefully.

Furniture parts are going to several manufacturing procedures. During this process, parts can have little dust or marks. Please clean the parts with damp cloth before assembly to get the best result. Usual cleaning would be suffice.

Valued Customer,

We design and carefully manufacture our products for our customers, We wish that our customers to have fun while they are doing their new furniture

The product you just purchased was subjected to all sorts of tests and controls before sending out to you.

Hope you enjoy your new furniture!!!



Do not use your furniture for out of purposes. If you would like to use it out of purpose or would like to do some modification or rotation, please contact us for more details.

Please do not expose your furniture with excessive heat, cold and humidity because product can be affected negatively.

Although all products are carefully manufactured and packed, sometimes we experience damage during transportation. In such cases, please check the damaged part, note the part number written on the part and do not hesitate to contact us

before you start

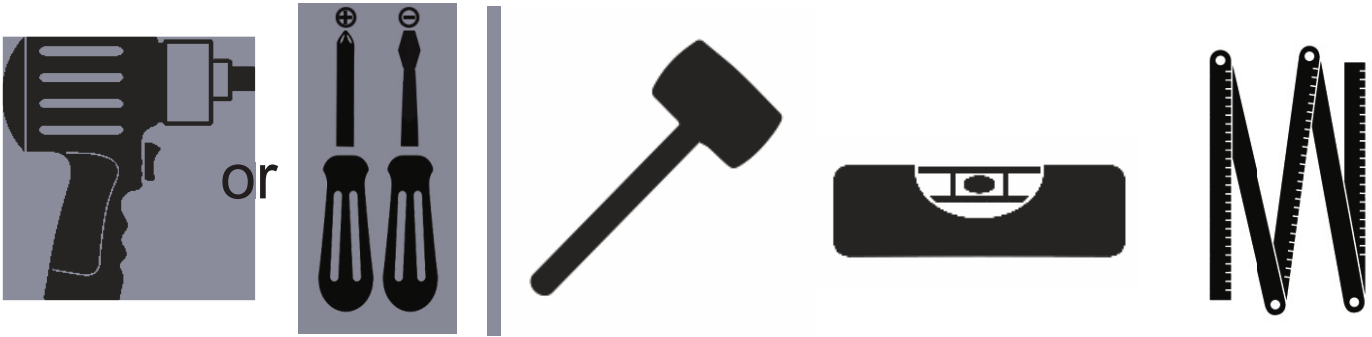

Get required installation tools prepared.

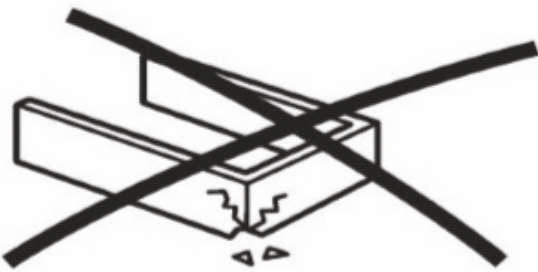

Do not install the product on rough surfaces.

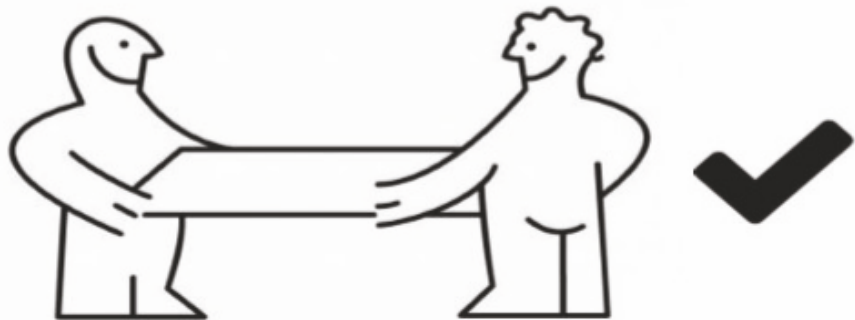
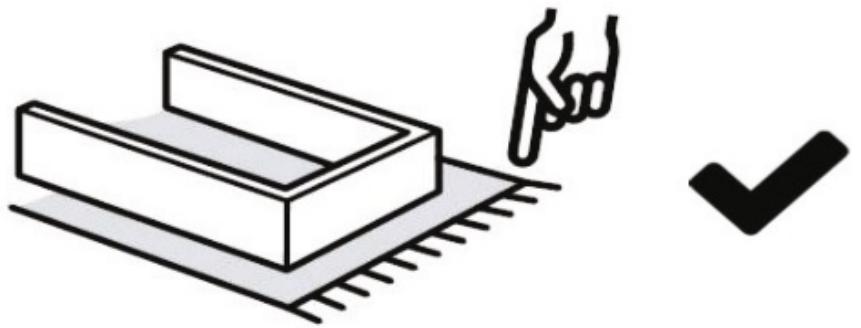

Get help from someone else!

getting familiar with the main components

*Minifix is the main connection component used in our products. Before starting, please check the below figures

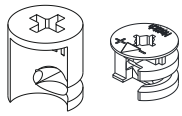

MINIFIX HEAD

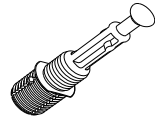

MINIFIX SCREW



DOWEL

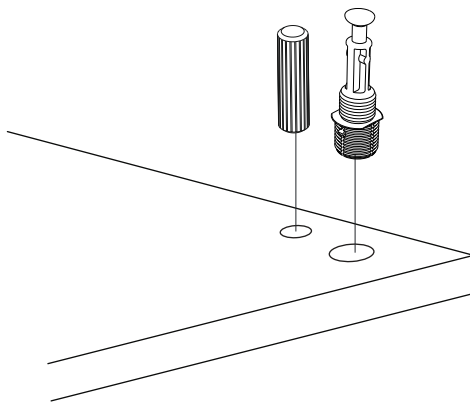

*Please notice that there is an small arrow on A02 (minifix head). This arrow should show the direction of upper hole.

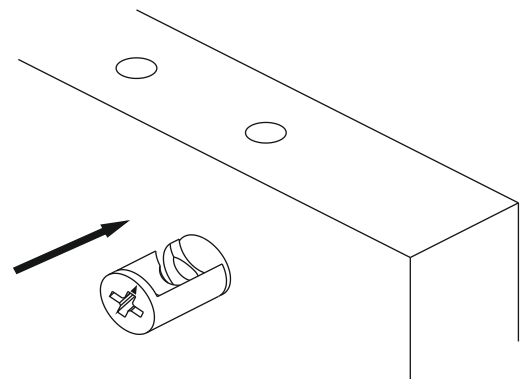

*A02(minifix head) and A03(minifix screw) help us to attach two wood pieces each other.



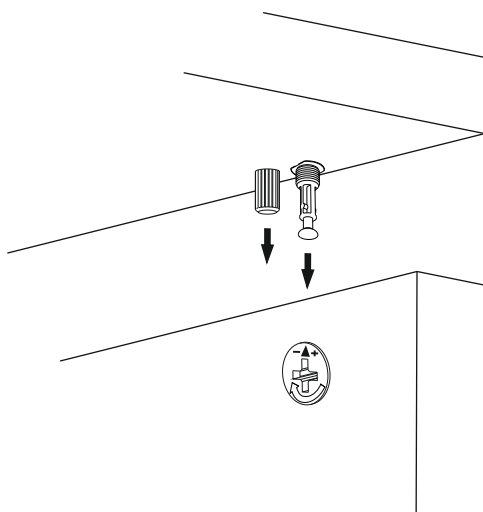

*After attaching two pieces please turn the A02 (minifix head) clockwise direction just a half tour with the help of a screwdriver.

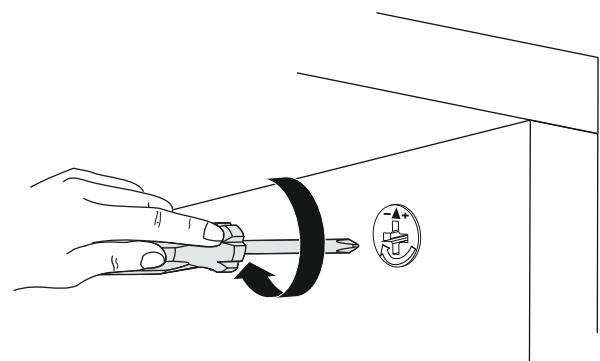

*Please do not over screw the A02 (minifix head) since it may be broken if too much power is imposed. Just make sure that it is screwed to the direction “+” do not go any further.

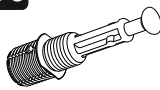

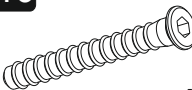
ACCESSORY LIST

A02 minifix head  28x	A03 minifix screw  28x	A07 12 mm sticker  c 1 4x	A13 50 mm sticker  4x	A06 18 mm sticker  c 1 28x
--	---	--	---	---

d1

GENERAL VIEW

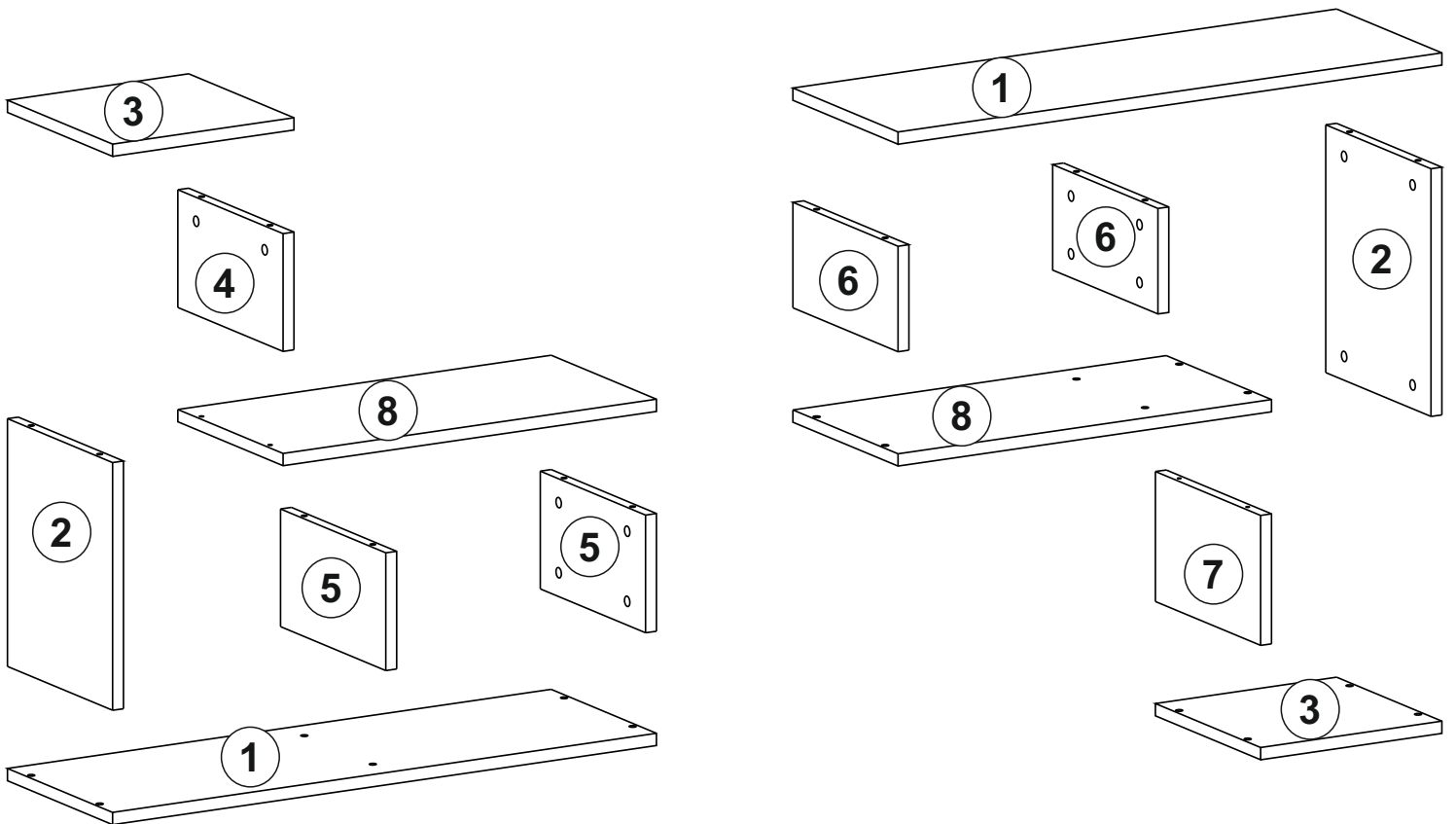

step a

1

- *Please insert A02 (minifix head) into the holes on the pieces #5 and #2 as shown below.
- *Make sure that all the arrows on A02 (minifix head) are in correct direction.

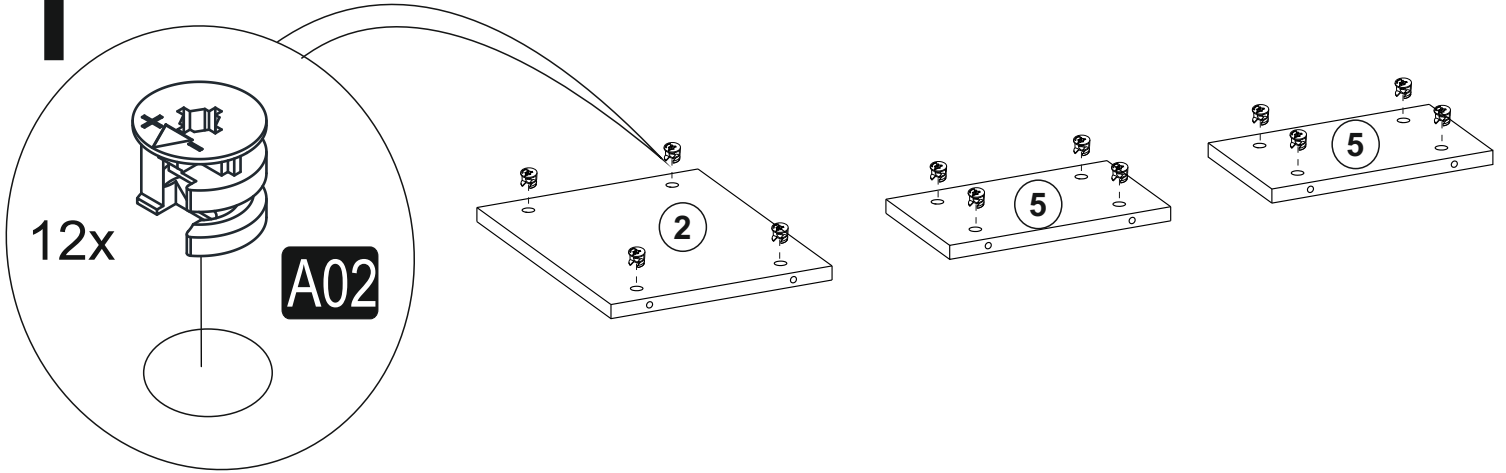

step b

- # 2
- *Please insert A03 (minifix screw) into the holes on the piece #1 as shown below.

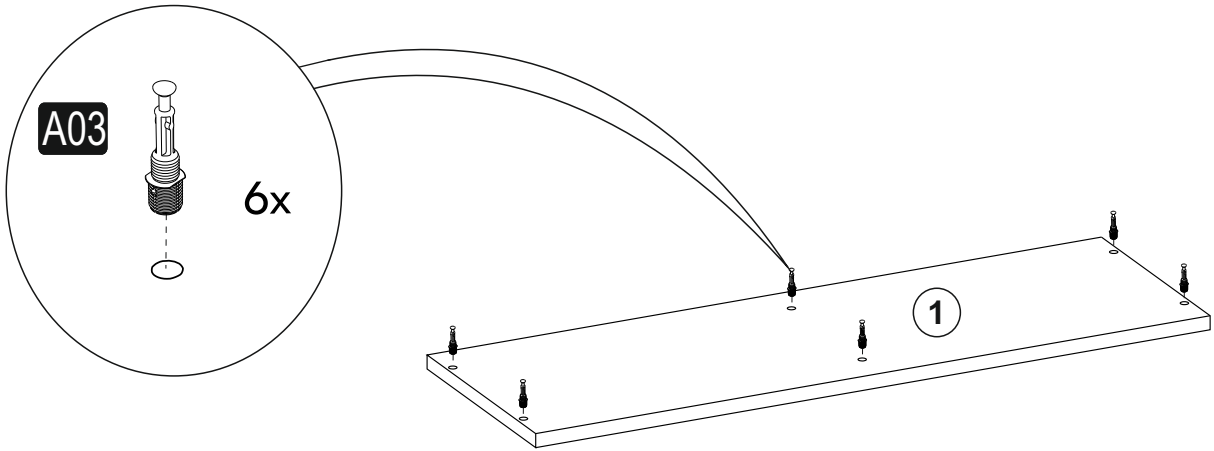

step c

- # 3
- *Please attach the pieces #5 and #2 onto the piece #1 as shown below.
 - *Now screw the A03 (minifix head) clockwise direction with the help of screwdriver.

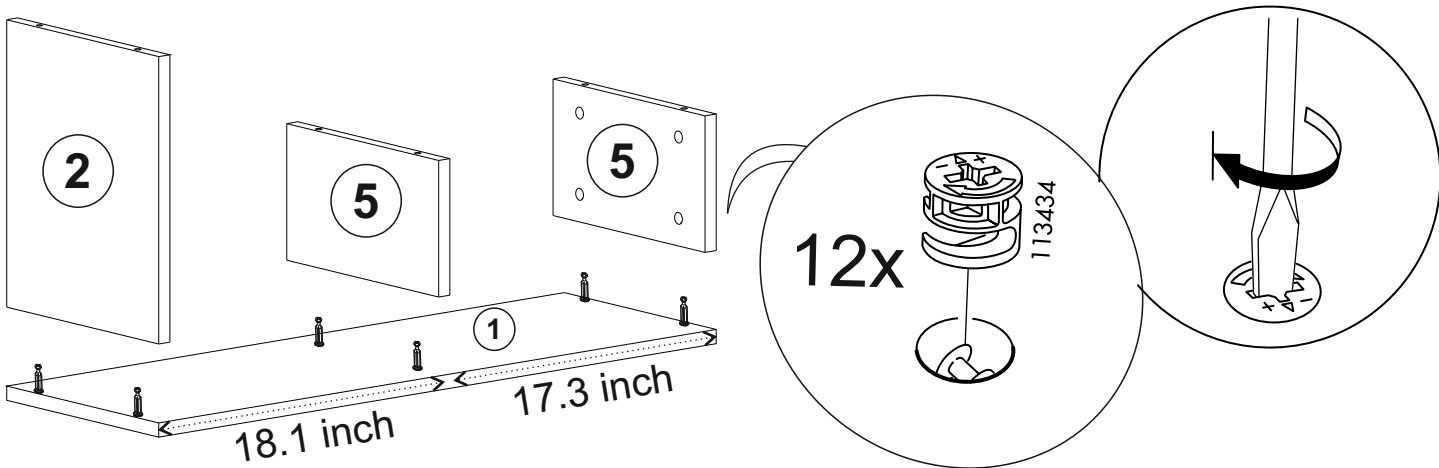

Shelf distances are different. They are not equal in terms of distance. So please watch the directions of pieces #2 and #5 and assemble according to diagram.

step d

- 4** *Please insert A03 (minifix screw) into the holes on the piece #3 and #8 as shown below.
*Please insert A02 (minifix head) into the holes on the piece #4 as shown below.
*Make sure that all the arrows on A02 (minifix head) are in correct direction.

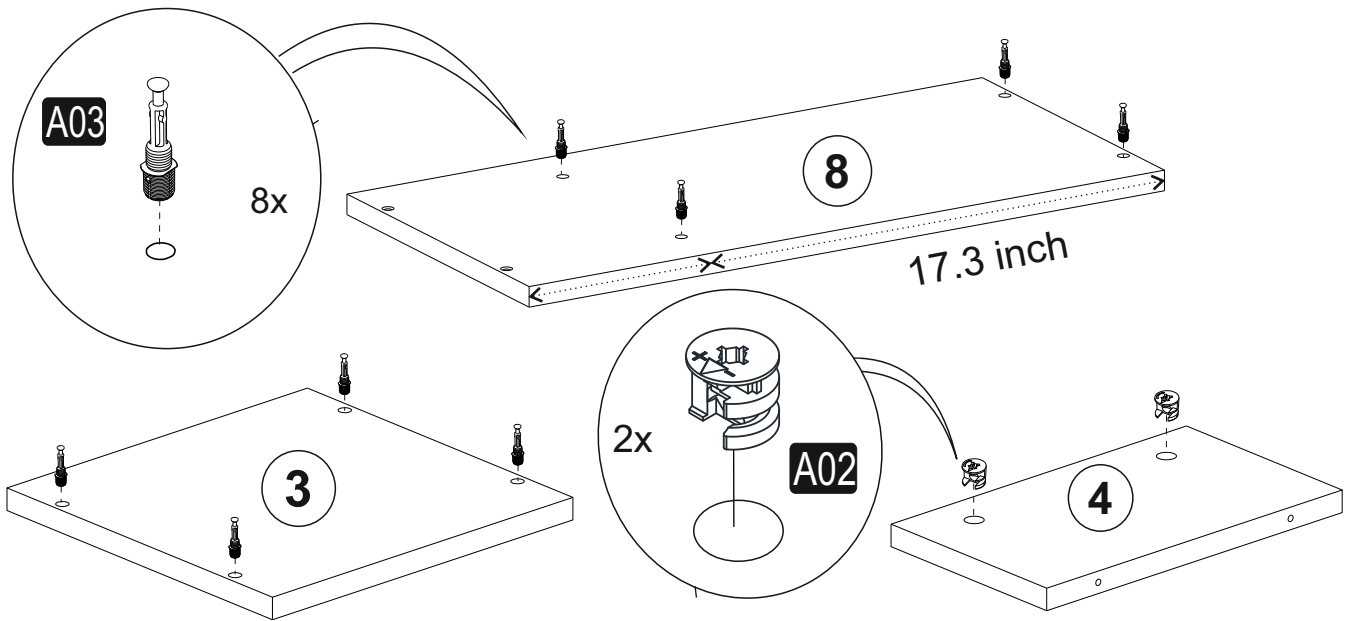

step e

- 5** *Please attach the piece #4 onto the piece #8 as shown below.
*Now screw the A13 (50 mm screw) clockwise direction with the help of screwdriver.

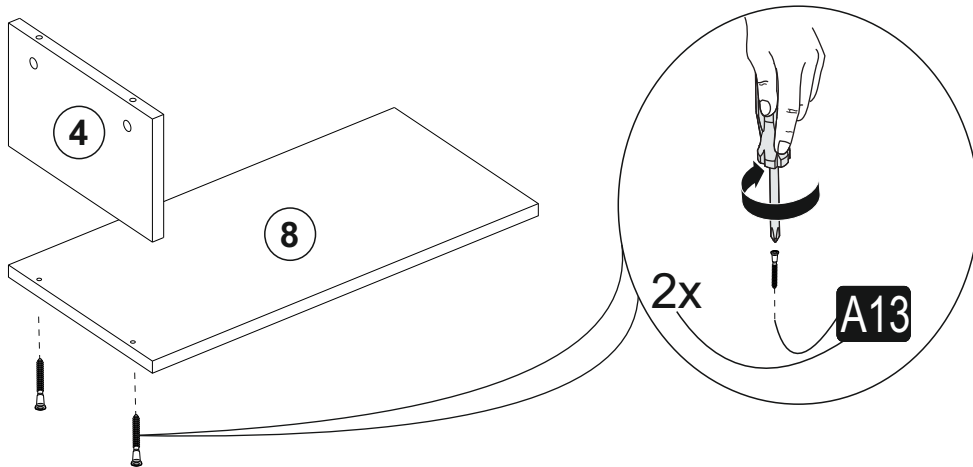

step f

- 6** *Please attach the part we installed in previous step to the pieces #5 as shown below.
*Now screw the A03 (minifix head) clockwise direction with the help of screwdriver.

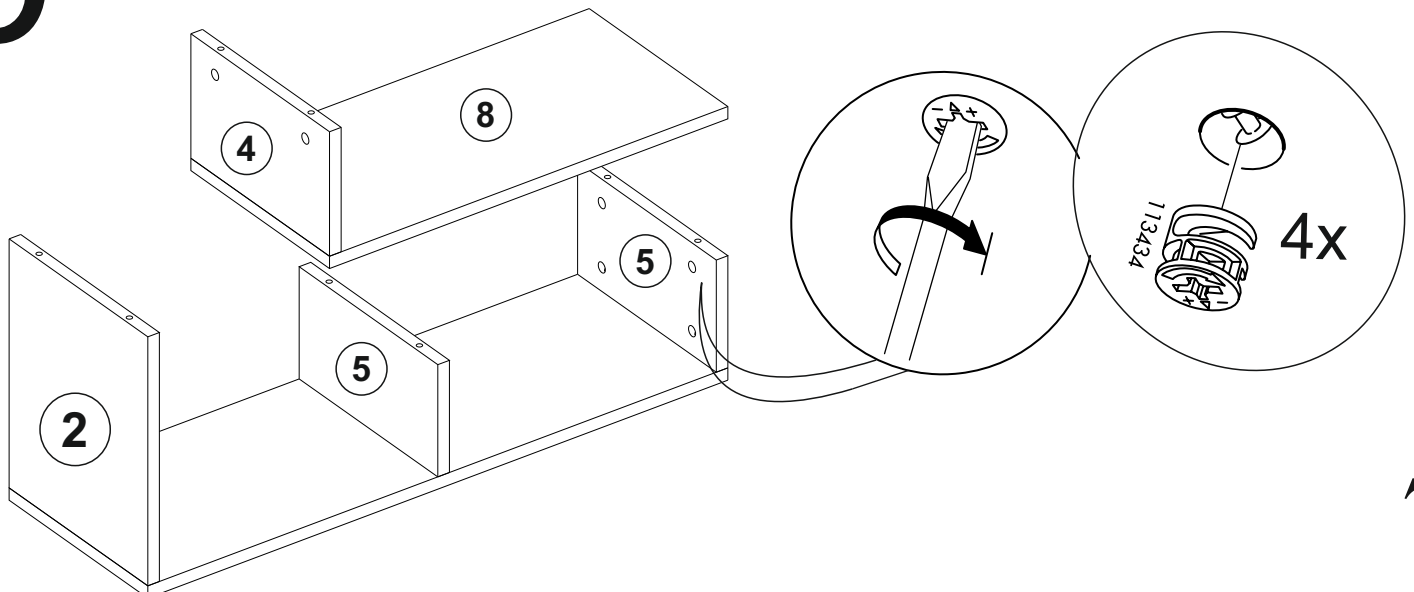

7 step g

- *Please attach the pieces #3 onto the pieces #2 and #4 as shown below .
- *Now screw the A03 (minifix head) clockwise direction with the help of screwdriver.

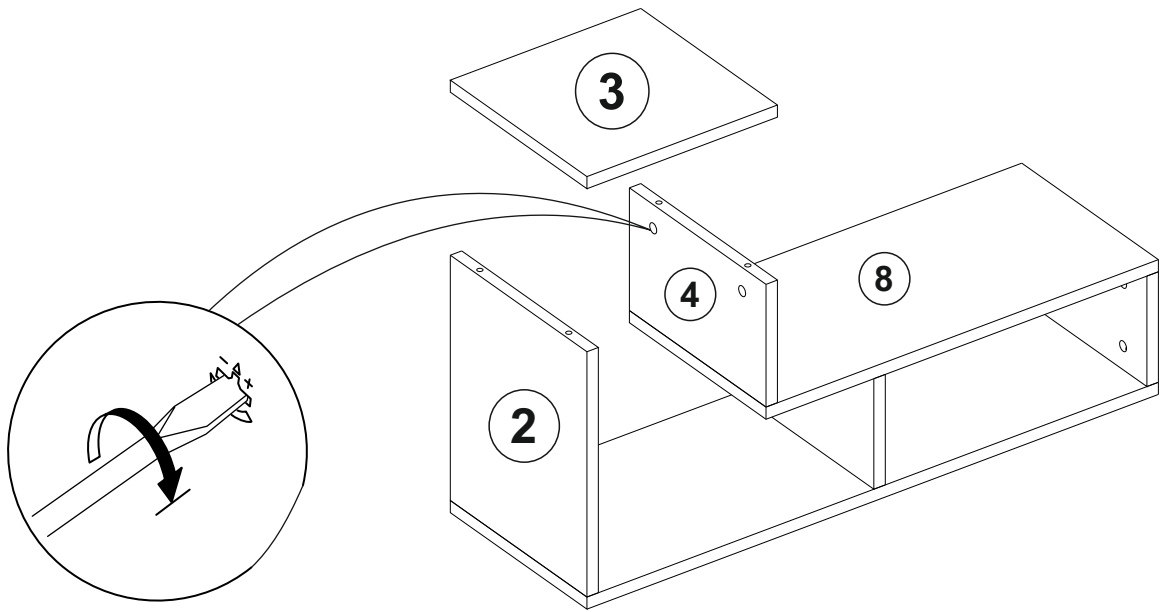

8 step h

- *Please insert A03 (minifix screw) into the holes on the piece #1 as shown below.
- *Please insert A02 (minifix head) into the holes on the piece #2 and #6 as shown below.
- *Make sure that all the arrows on A02 (minifix head) are in correct direction.

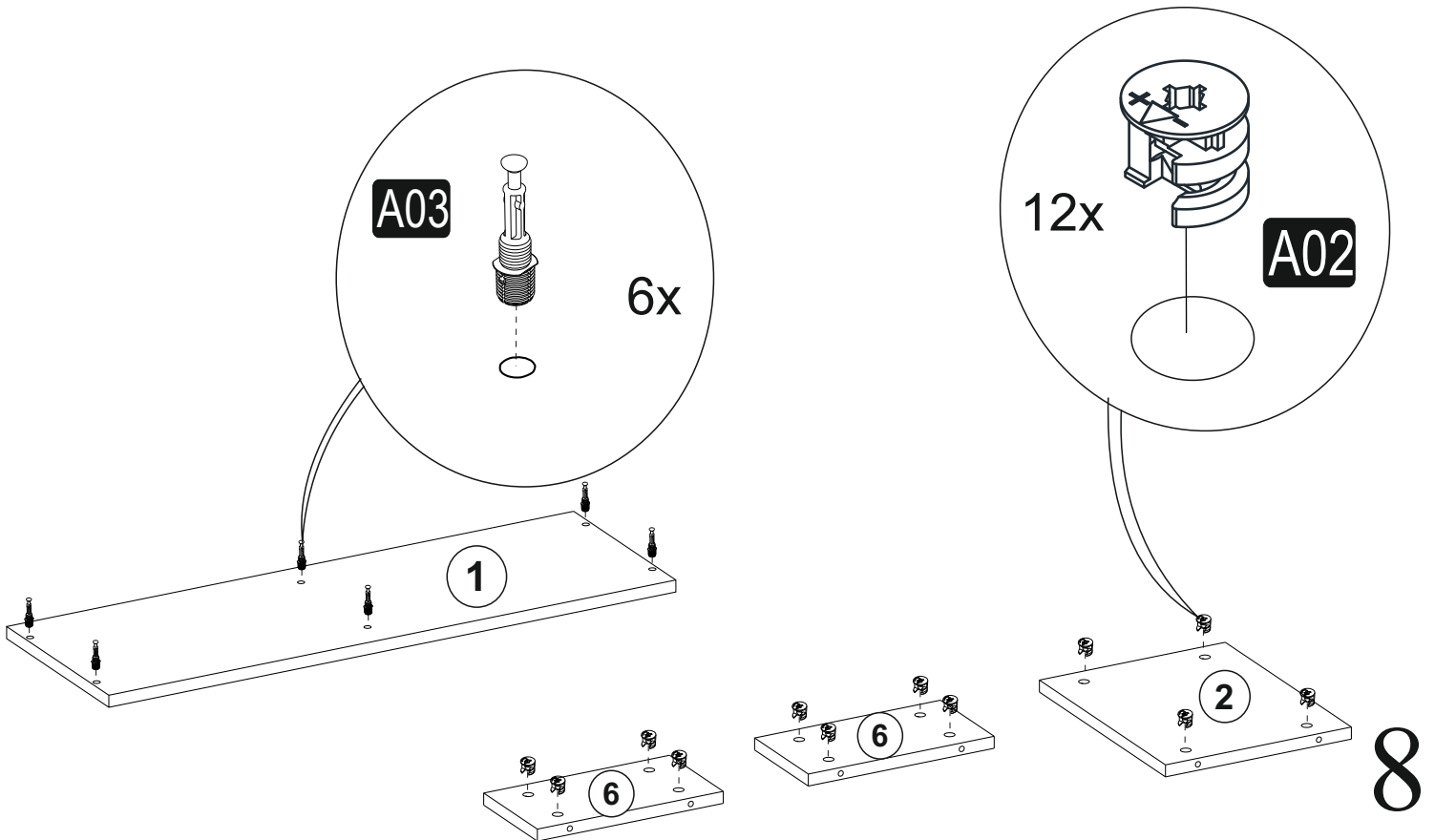

9 step i

*Please attach the pieces #6 and #2 onto the piece #1 as shown below.

*Now screw the A03 (minifix head) clockwise direction with the help of screwdriver.

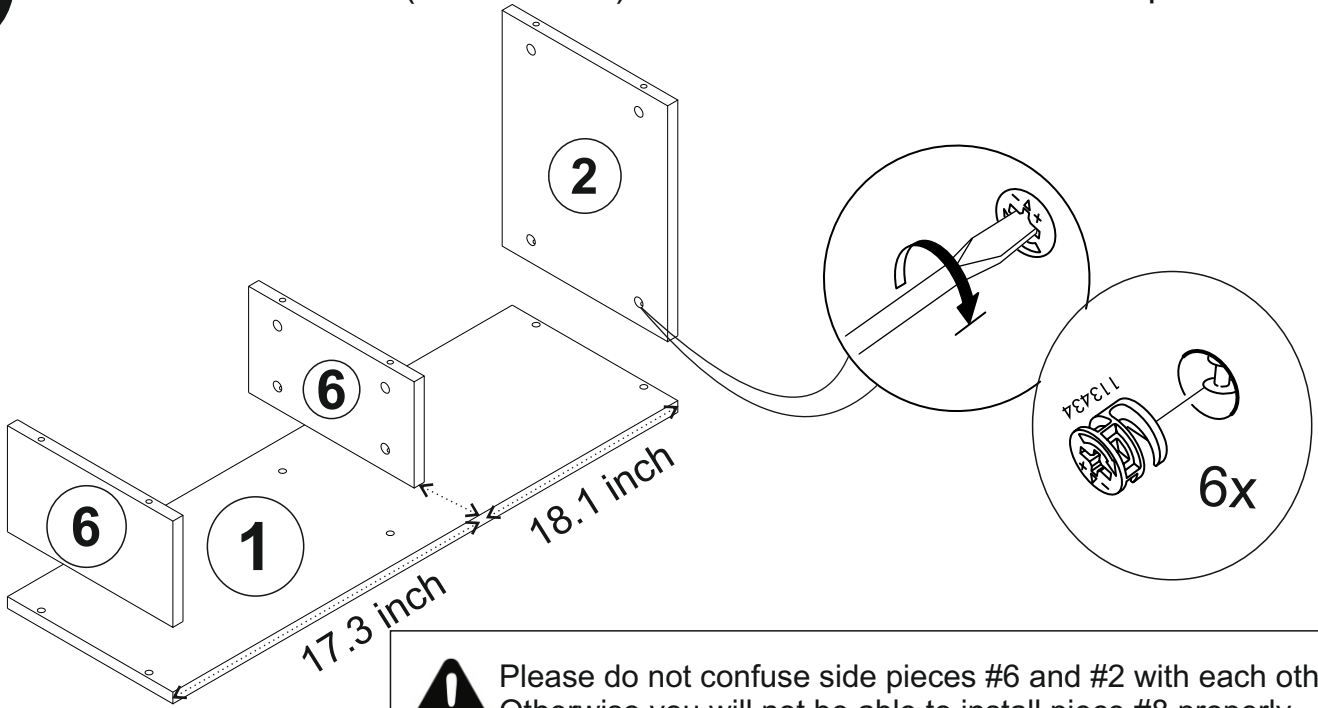

Please do not confuse side pieces #6 and #2 with each other. Otherwise, you will not be able to install piece #8 properly.

10 step j

*Please insert A03 (minifix screw) into the holes on the piece #3 and #8 as shown below

*Please insert A02 (minifix head) into the holes on the piece #7 as shown below

*Make sure that all the arrows on A02 (minifix head) are in correct direction

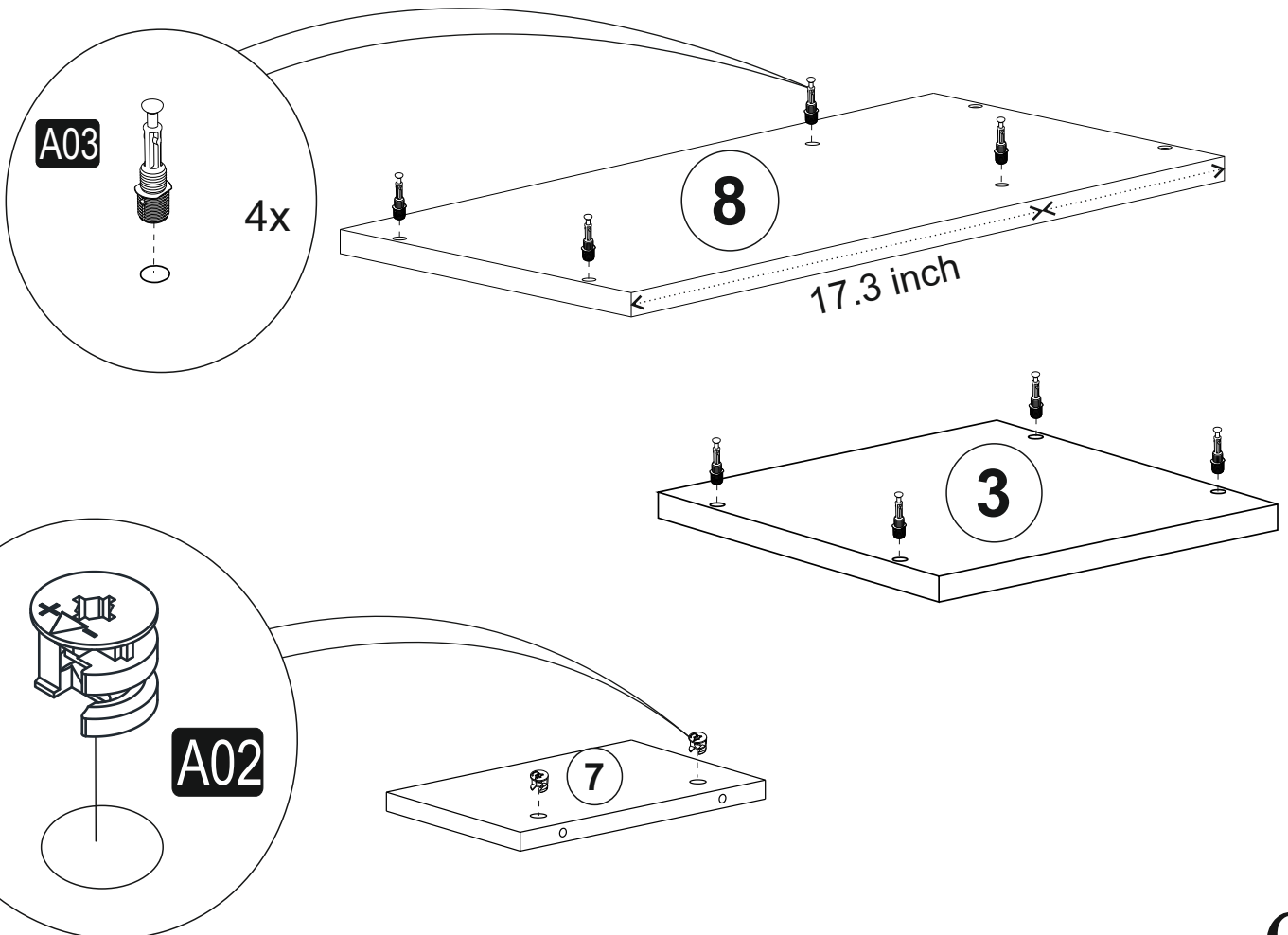

11 step k

*Please attach the piece #7 onto the piece #8 as shown below

*Now screw the A13 (50 mm screw) clockwise direction with the help of screwdriver.

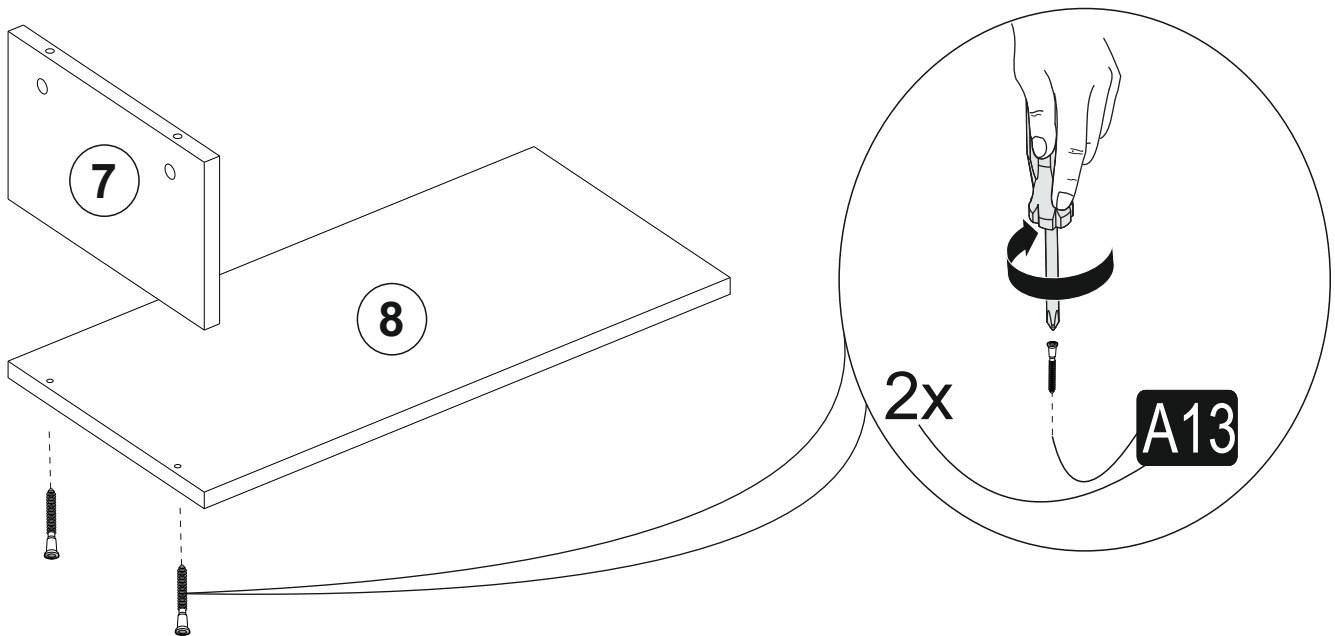

12 step l

*Please attach the part we installed in previous step to the pieces #5 as shown below

*Now screw the A03 (minifix head) clockwise direction with the help of screwdriver.

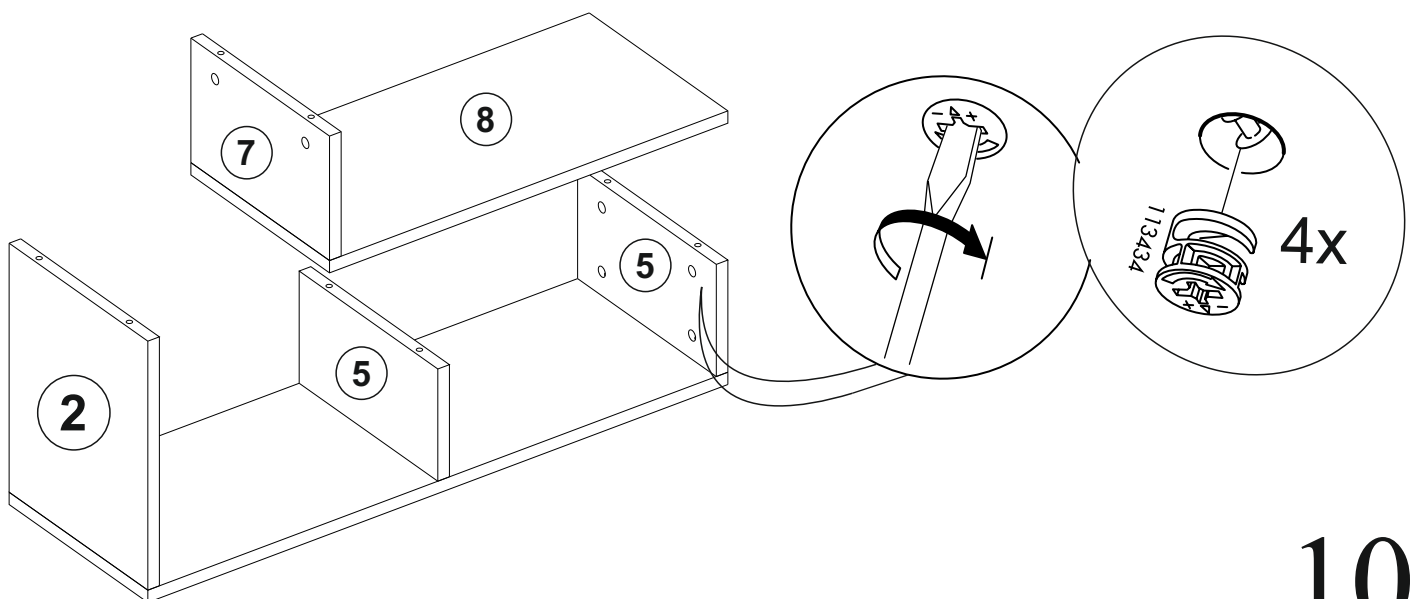

13 step m

*Please attach the piece #3 onto the pieces #7 and #2 as shown below.

*Now screw the A02 (minifix head) clockwise direction with the help of screwdriver.

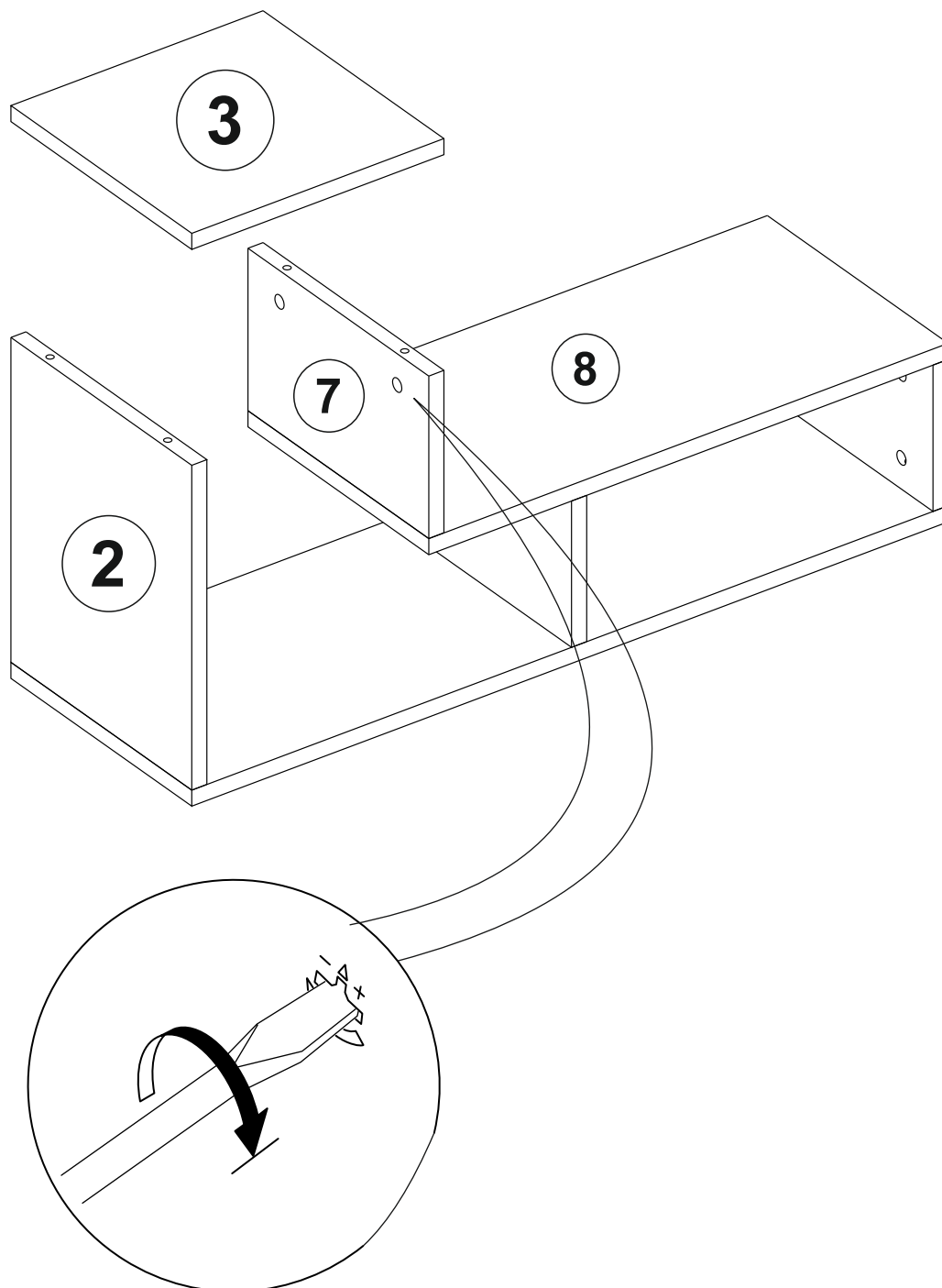

14

step n

*For the best appearance of your furniture please place all A07(12 mm sticker) onto the A13 (50 mm screw).

*For the best appearance of your furniture please place all A06(18 mm sticker) onto the A02 (minifix head).

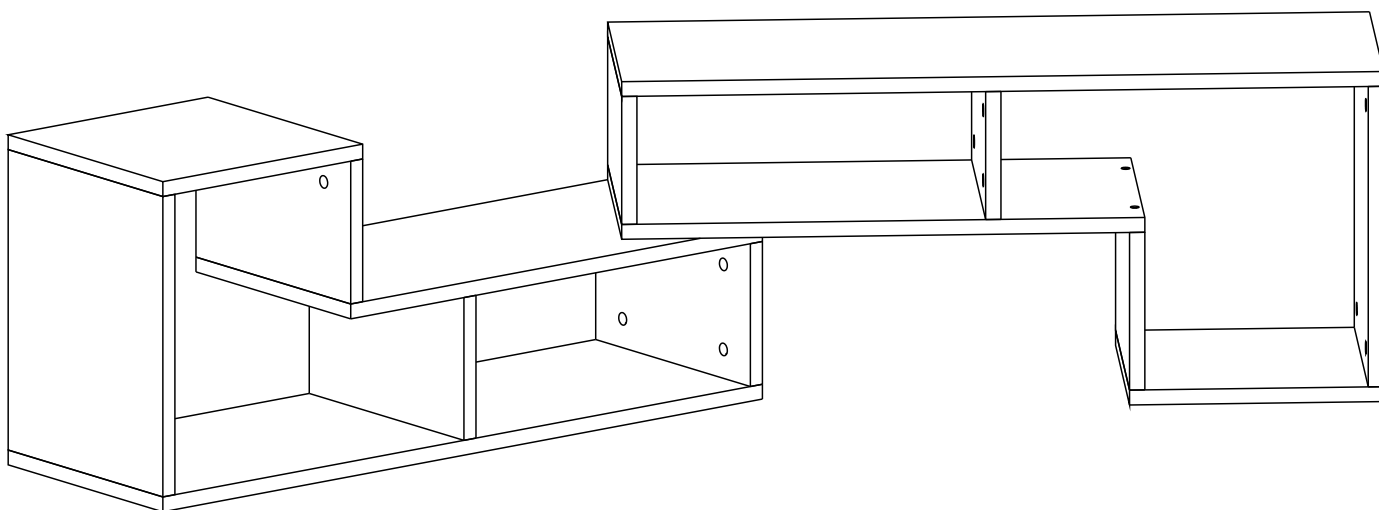
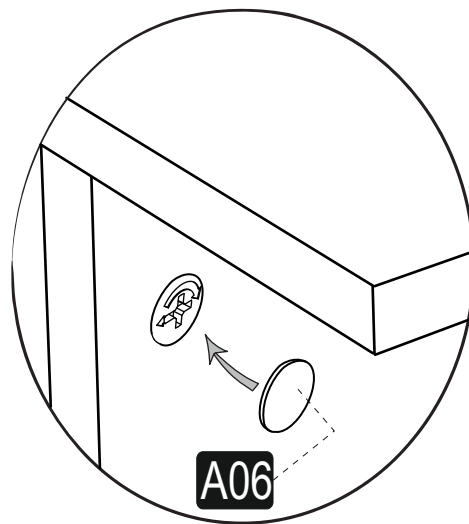
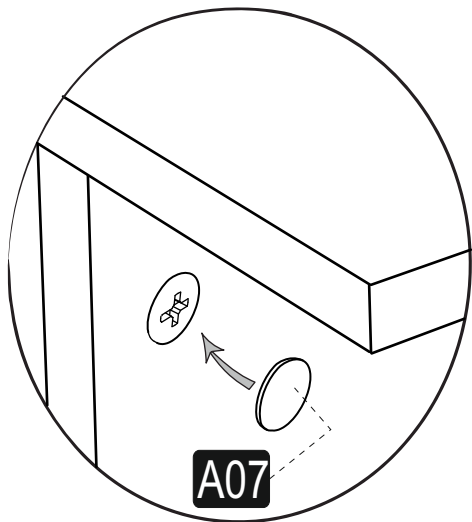

Enjoy your product!