

Hello!

Thank you for choosing one of our products. To assemble and use your new furniture in the best and safest way possible, please read the instructions and care tips carefully and follow them step by step. **We hope you enjoy your new furniture!**

And if there is a problem or something missing, use our contact details and the **Service Card** at the end of the manual.



Hallo,

Vielen Dank, dass Du Dich für eines unserer Produkte entschieden hast. Um Dein neues Möbel auf die beste und sicherste Art zu montieren und zu nutzen, lies bitte die Anleitung und die Pflegehinweise sorgfältig und befolge sie Schritt für Schritt. **Wir hoffen, dass Du viel Spaß mit Deinem neuen Möbel hast!** Und sollte etwas nicht richtig sein oder fehlen, dann nutze unsere Kontaktdaten und die **Service Card** am Ende der Anleitung.

¡Hola!

Muchas gracias por haber elegido uno de nuestros productos. Para montar y usar tu nuevo mueble de la mejor manera y de la forma más segura, lee las instrucciones y las indicaciones de cuidado detenidamente y síguelas paso a paso. **Esperamos que disfrutes mucho de tu nuevo mueble.** Si hubiera algo que no estuviera bien o faltara, usa nuestros datos de contacto y la **tarjeta de servicio** que hay al final de las instrucciones.

Ahoj!

Děkujeme, že jste se rozhodli pro jeden z našich výrobků. Abyste mohli co nejlépe a nejbezpečněji sestavit a využít svůj nový kus nábytku, přečtěte si prosím pozorně tento návod a pokyny pro péči a držte se jich. **Doufáme, že se vám nový nábytek bude líbit!** A pokud zjistíte, že něco není v pořádku nebo že něco chybí, použijte naše kontaktní údaje a **servisní kartu**, které najdete na konci tohoto návodu.

Здравствуйте!

Благодарим вас за то, что вы выбрали одно из наших изделий. Чтобы правильно и надежно собрать и использовать новую мебель, внимательно прочтите руководство и инструкции по уходу и выполняйте их шаг за шагом. **Надеемся, что вам понравится новая мебель!** Если же что-то не так или чего-то не хватает, воспользуйтесь нашими данными для связи и **сервисной картой** в конце данного руководства.

Bonjour !

Nous vous remercions chaleureusement d'avoir choisi l'un de nos produits. Afin de pouvoir monter et utiliser au mieux votre nouveau meuble et en toute sécurité, veuillez lire très attentivement ce manuel et les conseils d'entretien, puis suivre toutes les étapes à la lettre. **Nous espérons que votre nouveau meuble vous satisfera pleinement !** Si vous rencontrez le moindre problème ou une pièce venait à manquer, n'hésitez pas à nous contacter et à utiliser la **carte d'assistance** que vous trouverez à la fin de ce manuel.

Ciao!

Grazie per aver scelto uno dei nostri prodotti! Per montare e utilizzare i tuoi nuovi mobili nel modo migliore e più sicuro, leggi attentamente i suggerimenti e le istruzioni per la cura e seguili passo per passo. **Ci auguriamo che ti diverta con i tuoi nuovi mobili!** E se qualcosa non va o manca, utilizza i nostri dati di contatto e la **scheda di servizio** alla fine delle istruzioni.

Merhaba!

Ürünlerimizden birine kara verdiğin için teşekkür ederiz. Yeni mobilyanın montajını en iyi ve en güvenli şekilde yapmak ve kullanmak için talimatı ve bakım uyarılarını itinayla okuyun ve adım adım takip edin. **Yeni mobilyanı iyi günlerde kullanmanı diliyoruz!** Ve bir şey doğru değilse veya eksikse talimatın sonunda bulunan iletişim bilgilerimizi ve **servis kartını** kullanın.

Warning!

Warnung | Attention | Advertencia | Avvertimento | Varování | Uyarı | предупреждение

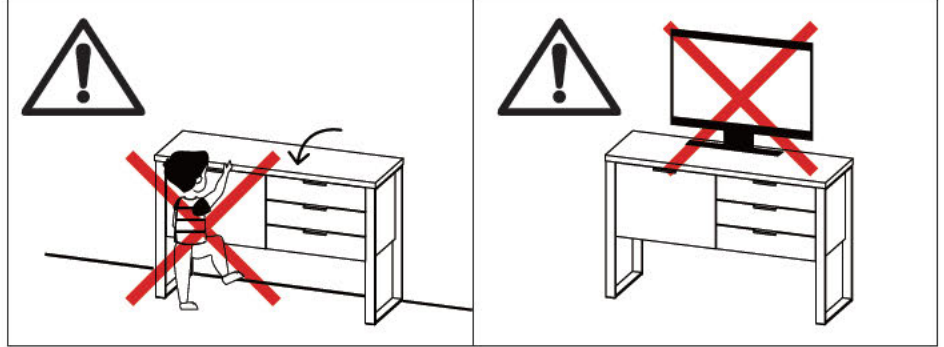

ENGLISH | WARNING!

Children have been injured or killed by furniture tipping over. To reduce the risk of furniture tipping over:

- NEVER place a television on this product
- NEVER allow children to climb or stand or hang on the drawers, doors, or bases.
- NEVER open more than one drawer or door at the same time
- Place the heaviest items in the lowest compartments/drawers



DEUTSCH | WARNUNG!

Kinder sind schon durch umkippende Möbel verletzt oder getötet worden. Um das Risiko von umkippenden Möbeln zu reduzieren:

- Stelle NIEMALS ein TV-Gerät auf dieses Produkt
- Erlaube Kindern NIEMALS, auf die Schubladen, Türen oder Böden zu klettern, sich darauf zu stellen oder sich daran zu hängen.
- Öffne NIEMALS mehr als eine Schublade oder eine Tür gleichzeitig
- Platziere die schwersten Dinge in den untersten Fächern/Schubladen



FRANÇAIS | ATTENTION!

Les enfants peuvent être blessés, voire tués, par la chute d'un meuble. Afin de réduire le risque de chute des meubles :

- Ne JAMAIS poser un téléviseur sur ce meuble
- Ne JAMAIS laisser les enfants grimper, s'accrocher ou se suspendre après les tiroirs, les portes ou le fond.
- Ne JAMAIS ouvrir plus d'un tiroir ou d'une porte en même temps
- Placer les objets les plus lourds sur les étagères ou dans les tiroirs du bas



ESPAÑOL | ¡ADVERTENCIA!

Hay niños que han sufrido lesiones o han muerto debido al vuelco de muebles. Para reducir el riesgo de que los muebles vuelquen:

- No pongas NUNCA una televisión sobre este producto.
- No permitas NUNCA que los niños trepen, se pongan de pie o se cuelguen de los cajones, las puertas o de los estantes.
- No abras NUNCA más de un cajón o de una puerta al mismo tiempo.
- Coloca los objetos más pesados en los compartimentos/cajones inferiores.



ITALIANO | AVVERTIMENTO!

Il ribaltamento dei mobili ha già causato lesioni gravi o mortali ai bambini. Per ridurre il rischio di ribaltamento dei mobili:

- Non collocare MAI una TV su questo prodotto
- Non permettere MAI ai bambini di arrampicarsi, salire o appendersi ai cassetti, ante o ripiani.
- Non aprire MAI più di un cassetto o di una porta contemporaneamente
- Mettere gli oggetti più pesanti nei ripiani/cassetti inferiori



ČEŠTINA | VAROVÁNÍ!

Existují případy, kdy v důsledku převržení nábytku došlo ke zranění nebo usmrcení dítěte. V zájmu snížení rizika převržení nábytku:

- NIKDY na tento výrobek neumísťujte televizor.
- NIKDY nedovoľte deťom, aby lezli, stoupaly nebo se věšely na zásuvky, dvířka či police.
- NIKDY neotvírejte současně více než jednu zásuvku nebo jednu dvířka.
- Nejtěžší předměty umístěte do nejnižších přihrádek/zásuvek.



TÜRKÇE | UYARI!

Çocuklar daha önce mobilyaların devrilmesi nedeniyle yaralandı veya öldü. Devrilen mobilyaların riskini azaltmak için yapılacaklar:

- Bu ürünün üzerine ASLA bir televizyon yerleştirmeyin
- Çocuklara ASLA çekmecelerin, kapıların veya zeminlerin üzerine çıkmasına, durmasına veya asılmasına izin vermeyin.
- Aynı anda ASLA bir çekmecedan veya kapıdan fazlasını açmayın
- En ağır eşyaları en alt bölmelere/çekmecelere yerleştirin



НЕМЕЦКИЙ | ПРЕДУПРЕЖДЕНИЕ!

Уже бывали случаи, когда в результате опрокидывания мебели дети получали травмы, в том числе смертельные. Чтобы снизить риск опрокидывания мебели:

- НИ В КОЕМ СЛУЧАЕ не ставьте на это изделие телевизор.
- НИКОГДА не позволяйте детям взбираться, становиться или висеть на выдвигаемых ящиках, дверцах или полках.
- НИКОГДА не открывайте более одного ящика или дверцы одновременно.
- Кладите самые тяжелые вещи в самые нижние ящики/отделения.



Warning!

Warnung | Attention | Advertencia | Avvertimento | Varování | Uyarı | предупреждение



ENGLISH | WARNING!

- The installation should be done on cardboard or a soft surface that can be wiped off.
- DO NOT use any cordless screwdrivers.
- Assembly may ONLY be carried out with at least 2 adults. Be sure to keep children away, as it may contain small parts!
- If you have any questions, just give us a call.
- Please only use the furniture as directed.
- Under NO circumstances should you sit or climb on the product! Pay special attention to children!
- The product is ONLY suitable for use for its intended purpose!
- This product is NOT intended for commercial use
- Do NOT place food directly on the product



DEUTSCH | WARNUNG!

- Die Montage sollte auf Karton oder einer weichen, abwischbaren Unterlage erfolgen.
- KEINEN Akkuschauber nutzen.
- Die Montage darf NUR mit mind. 2 Erwachsenen durchgeführt werden. Kinder in jedem Fall fernhalten, da Kleinteile enthalten sein können!
- Bei Fragen einfach anrufen.
- Bitte belaste das Möbelstück nur wie angegeben.
- In KEINEM Fall darf man sich auf das Produkt setzen, daran hochklettern oder darauf steigen! Passe besonders auf Kinder auf!
- Das Produkt ist NUR zur Nutzung für den vorgesehenen Zweck geeignet!
- Dieses Produkt ist NICHT für den gewerblichen Einsatz gedacht
- Lege KEINE Lebensmittel direkt auf das Produkt



FRANÇAIS | ATTENTION!

- Le montage doit être réalisé sur du carton ou sur une surface souple et essuyable.
- NE PAS utiliser de visseuse sans fil.
- Le montage doit UNIQUEMENT être effectué par au moins 2 personnes adultes. Toujours éloigner les enfants car le produit peut contenir des petites pièces !
- Des questions ? Appelez-nous !
- Charger les meubles uniquement comme indiqué.
- Ne JAMAIS s'asseoir, grimper ou monter sur le produit ! Faire particulièrement attention aux enfants !
- Le produit est UNIQUEMENT adapté à l'utilisation prévue !
- Ce produit N'EST PAS destiné à un usage commercial
- NE PAS mettre de nourriture directement sur le produit



ESPAÑOL | ¡ADVERTENCIA!

- El montaje debe realizarse sobre cartón o sobre una superficie blanda y lavable.
- NO usar un atornillador a batería.
- El montaje debe realizarse ÚNICAMENTE por un mínimo de 2 personas adultas. ¡Mantener a los niños alejados, ya que puede contener piezas pequeñas!
- En caso de preguntas o dudas, simplemente llama.
- Por favor, aplica carga sobre el mueble solo según lo indicado.
- ¡En NINGÚN caso se debe trepar, sentarse o subir sobre el producto!
- ¡Vigila especialmente a los niños!
- ¡El producto es apto SOLO para usarlo según la finalidad prevista para el mismo!
- Este producto NO está concebido para un uso comercial.
- NO dejes alimentos directamente sobre el producto.



ITALIANO | AVVERTIMENTO!

- Il montaggio dovrebbe essere effettuato su un cartone o su una superficie morbida e lavabile.
- NON utilizzare un avvitatore a batteria.
- Il montaggio può essere effettuato SOLO da un minimo di 2 adulti. Tenere sempre i bambini lontani, in quanto potrebbe contenere parti piccole!
- In caso di domande, contattaci.
- Si prega di caricare i mobili solo come indicato.
- Non sedersi, arrampicarsi o salire in NESSUN caso sul prodotto! Fare attenzione ai bambini!
- Il prodotto è adatto SOLO per lo scopo previsto!
- Il prodotto NON è pensato per l'utilizzo in ambito commerciale.
- Non mettere cibi direttamente sul prodotto



ČEŠTINA | VAROVÁNÍ!

- Montáž provádějte na kartonu nebo měkké, omyvatelné podložce.
- NEPOUŽÍVEJTE akumulátorový šroubovák.
- Montáž musí provádět NEJMÉNĚ 2 dospělí osoby. V každém případě udržujte děti v bezpečné vzdálenosti, protože výrobek může obsahovat malé součásti!
- V případě dotazů nám jednoduše zavolejte.
- Dodržujte prosím uvedenou maximální nosnost nábytku.
- V ŽÁDNÉM případě na výrobek nesedejte, nelezte a nestoupejte! Dávejte pozor zejména na děti!
- Výrobek používejte POUZE pro účel, pro který je určen!
- Tento výrobek NENÍ určen pro komerční využití.
- NIKDY nepokládejte potraviny přímo na výrobek.



TÜRKÇE | UYARI!

- Montaj işlemi karton veya yumuşak silinebilen bir altlığın üzerinde yapılmalıdır.
- Akülü vidalayıcı KULLANMAYIN.
- Montaj işlemi SADECE en az 2 yetişkinle yapılabilir. Küçük parçalar bulunabileceğinden çocukları kesinlikle uzak tutun!
- Sorularınız olduğunda arayın.
- Mobilyalara sadece belirtildiği gibi yük uygulayın.
- HİÇBİR DURUMDA ürünün üzerine oturulmamalı, tırmanmamalı veya çıkılmamalıdır! Özellikle çocuklara dikkat edin!
- Ürün SADECE öngörüldüğü amaç için kullanılması uygundur!
- Ürün ticari kullanım için ÖNGÖRÜLMEMİŞTİR.
- Ürünün üzerine doğrudan gıda maddeleri KOYMAYIN



РУССКИЙ | ПРЕДУПРЕЖДЕНИЕ!

- Сборку следует производить на картоне или мягкой моющейся поверхности.
- НЕ ИСПОЛЬЗУЙТЕ аккумуляторный шуруповерт.
- Сборку должны производить ПО МЕНЬШЕЙ МЕРЕ двое взрослых. Ни в коем случае не подпускайте детей, так как в комплекте есть мелкие детали!
- В случае возникновения вопросов просто позвоните.
- Нагружайте мебель только в соответствии с указаниями.
- Ни в коем случае нельзя садиться, взбираться или становиться на изделие! Следите за детьми!
- Изделие подходит ТОЛЬКО для использования по прямому назначению!
- Это изделие НЕ предназначено для коммерческого использования.
- НЕ кладите пищевые продукты прямо на изделие.

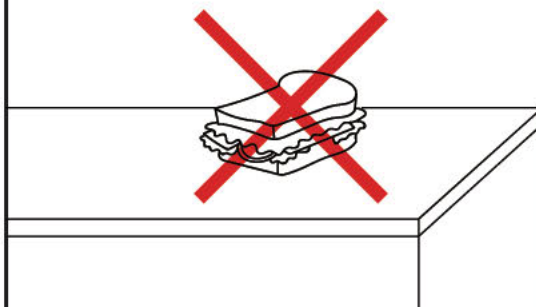
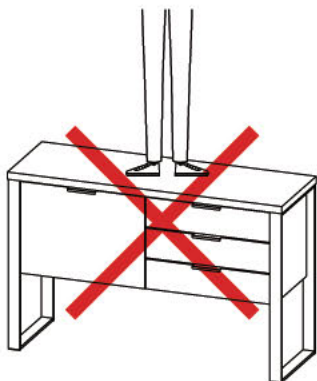
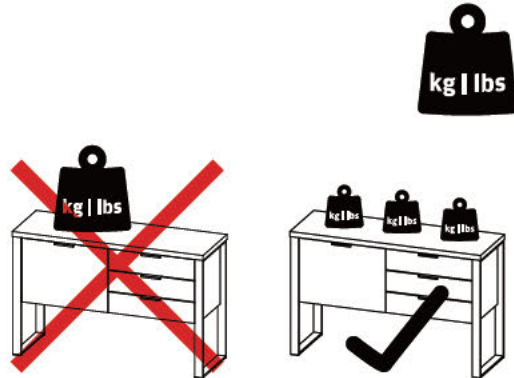
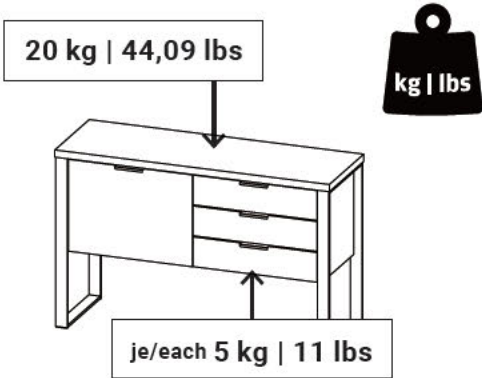
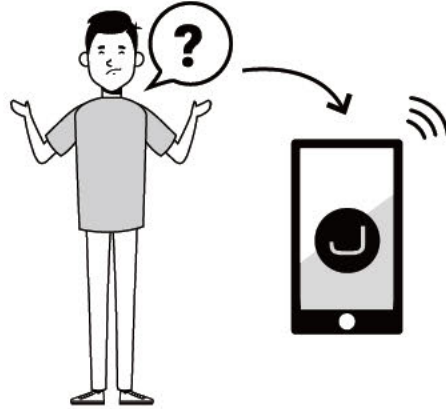
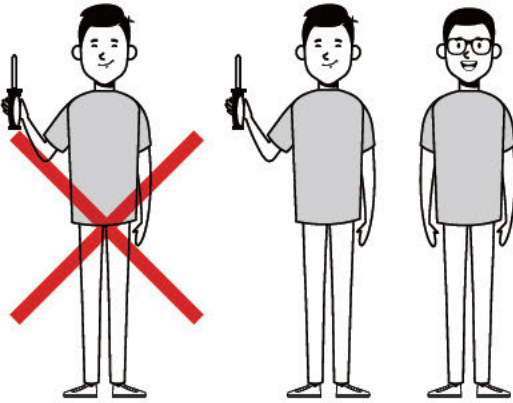
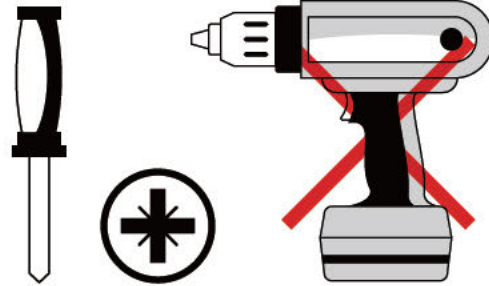
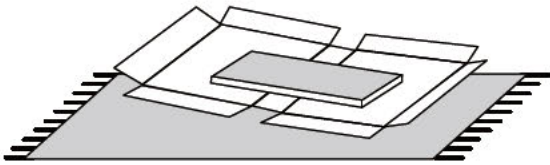

LOOP Coffee

20 kg | 44,09 lbs

kg | lbs

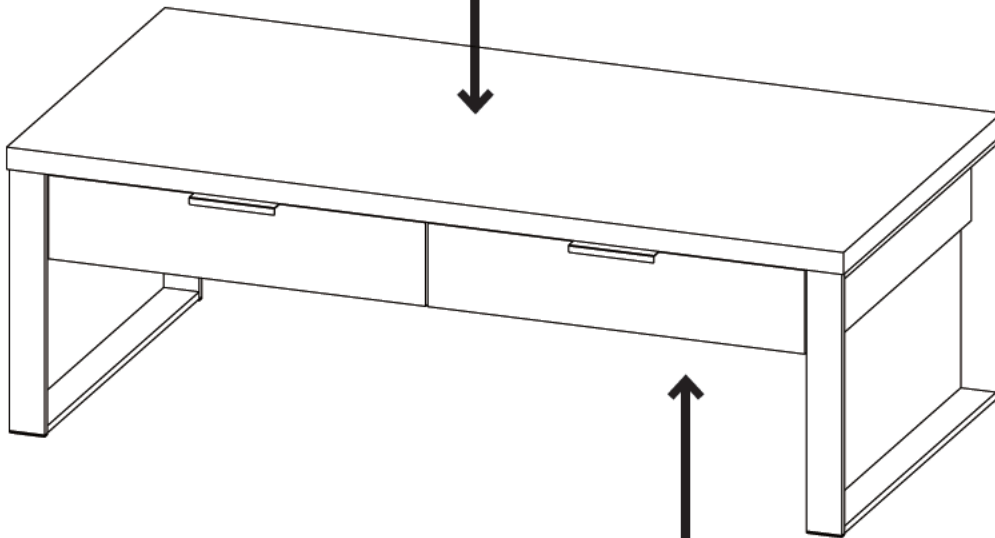

each / je / chaque / cada 5 kg | 11 lbs

Parts



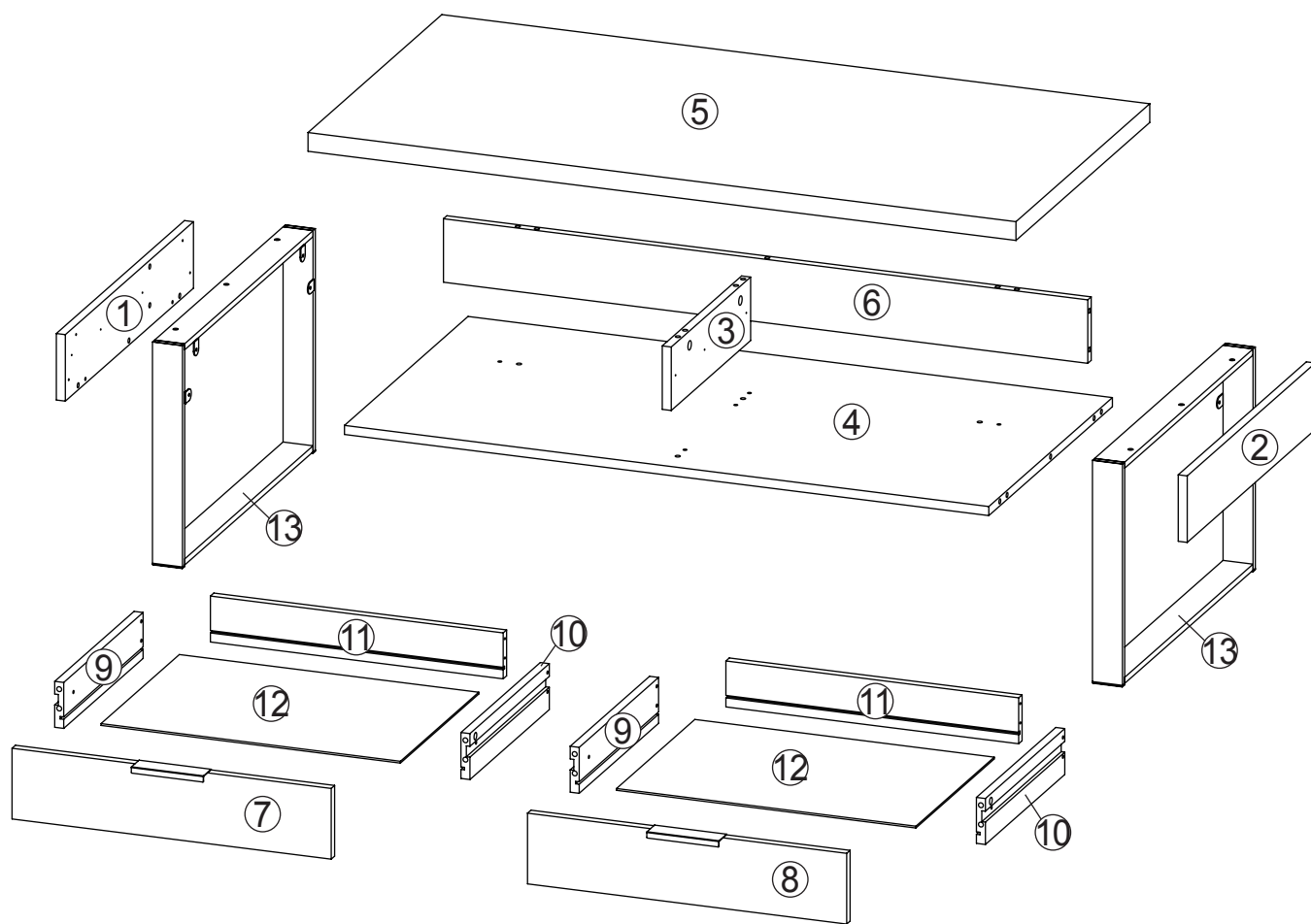







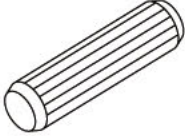

Bauteile | Composants | Componentes | Componenti | Součásti | Bileşenler | Компоненты





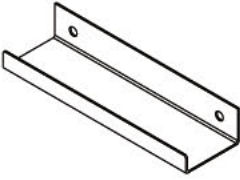

Hardware

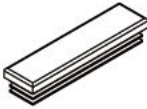
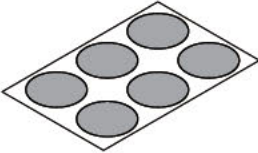
Zubehörteile | équipement | equipo | attrezzature | zařízení | ekipman | оборудование



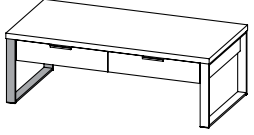



<p>A 1x</p> <p>GLUE LEIM La colle Pegamento</p>  <p>Do not swallow. Keep away from children! Nicht verschlucken. Von Kindern fernhalten! Ne pas avaler. Garder loin des enfants! No lo tragues. ¡Manténgalo alejado de los niños!</p>	<p>B 23x</p> 	<p>C 12x</p> 	<p>D 8x</p> 
<p>E 5x</p> 	<p>F 8x</p> 	<p>G 4x</p> 	<p>H 24x</p> 
<p>I 4x</p> 	<p>J 2x</p> 	<p>K 4x</p> 	<p>L 6x</p> 
<p>M 1x</p> 	<p>N 4x</p> 	<p>O 2x</p> 	

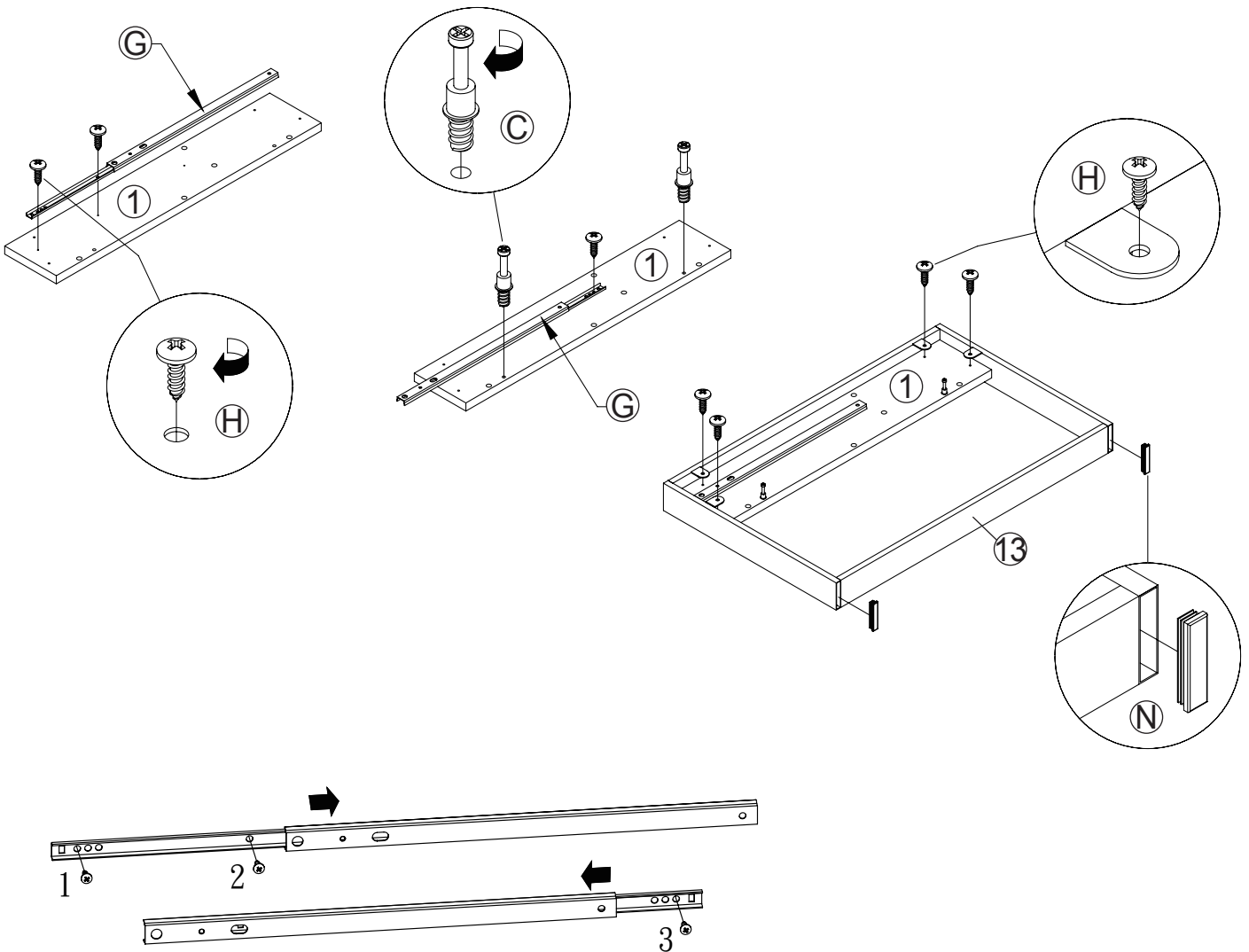

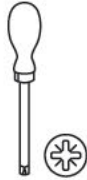
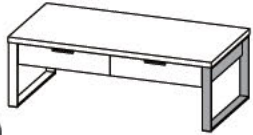
Start here!

1	C	G	H	N		
	 2x	 1x	 7x	 2x		

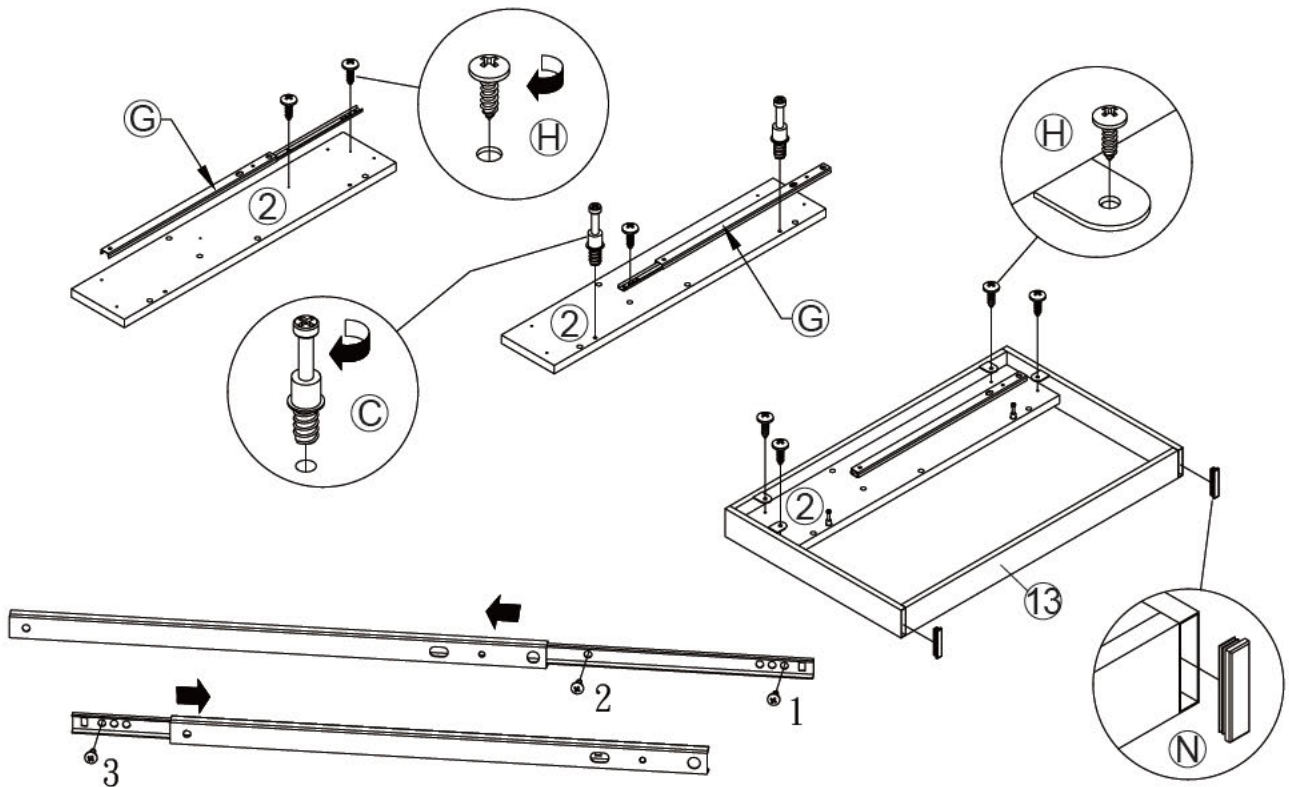

<h1>2</h1>	C	G	H	N	 
	 2x	 1x	 7x	 2x	

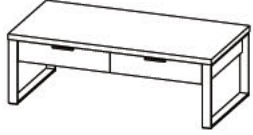

<h1>3</h1>	A	B	
	 LEIM/GLUE	 15x	

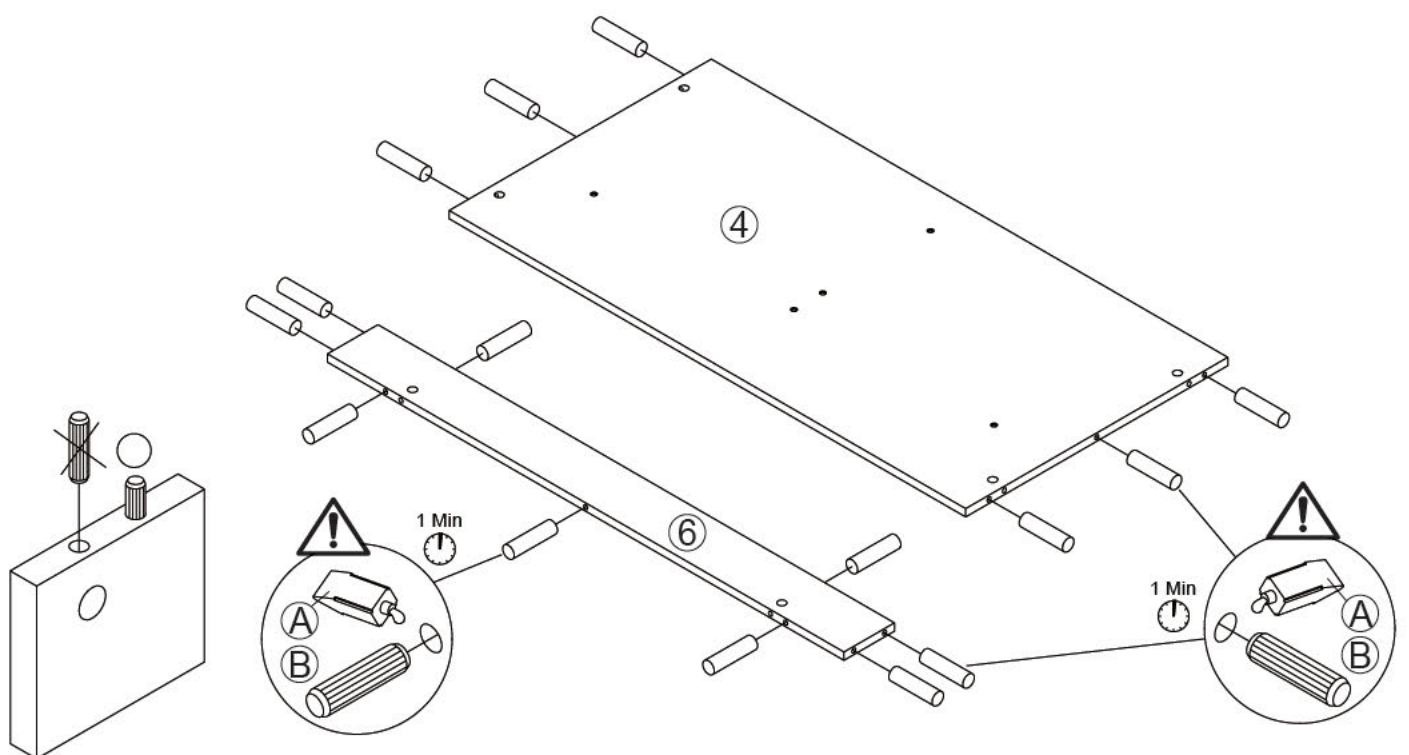

4

A



LEIM/GLUE

B



4x

G



2x

H



6x

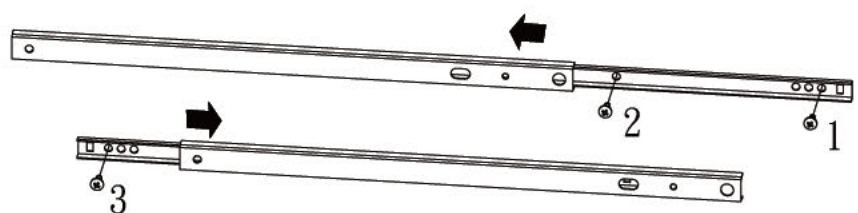
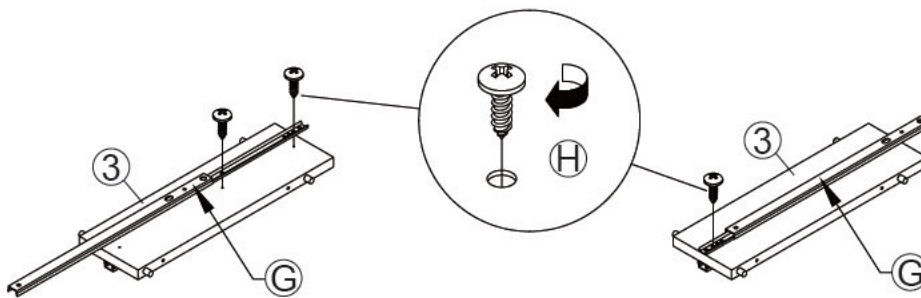
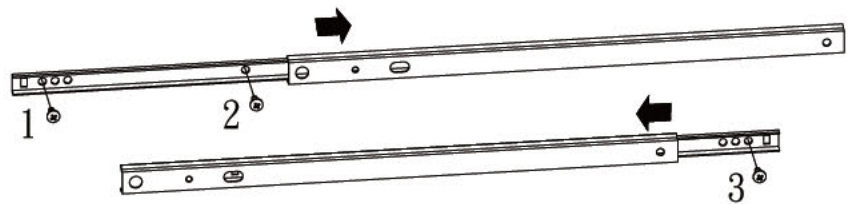
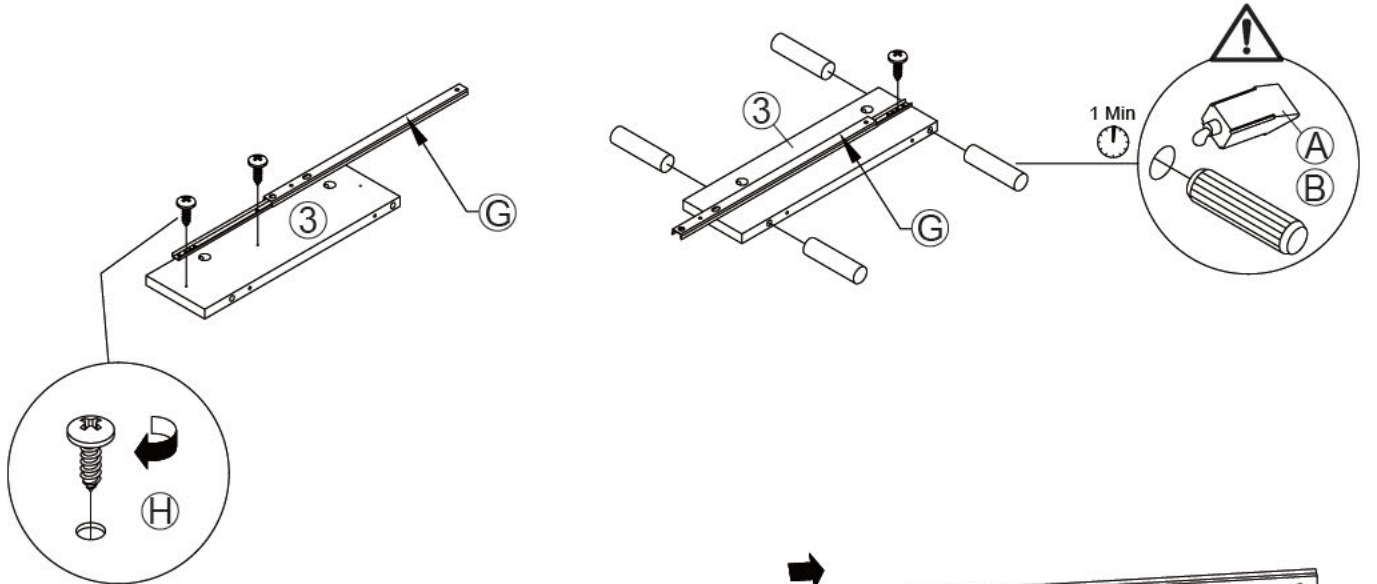
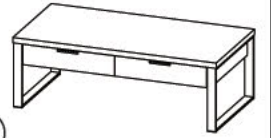

5

A E

LEIM/GLUE 5x

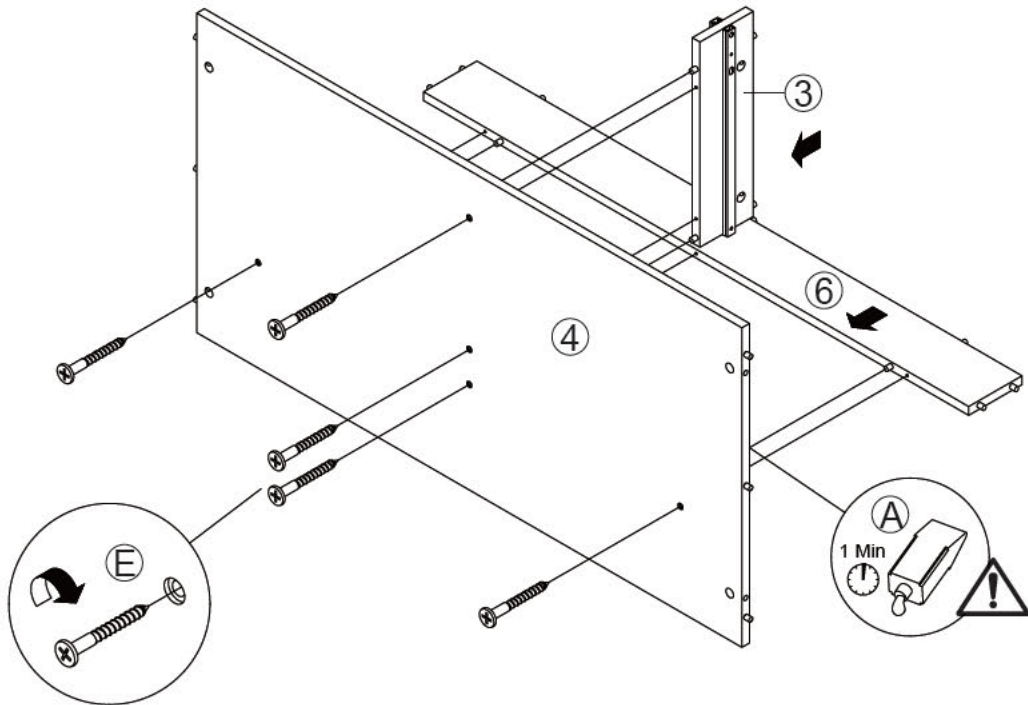

6

A D O

LEIM/GLUE 4x 4x

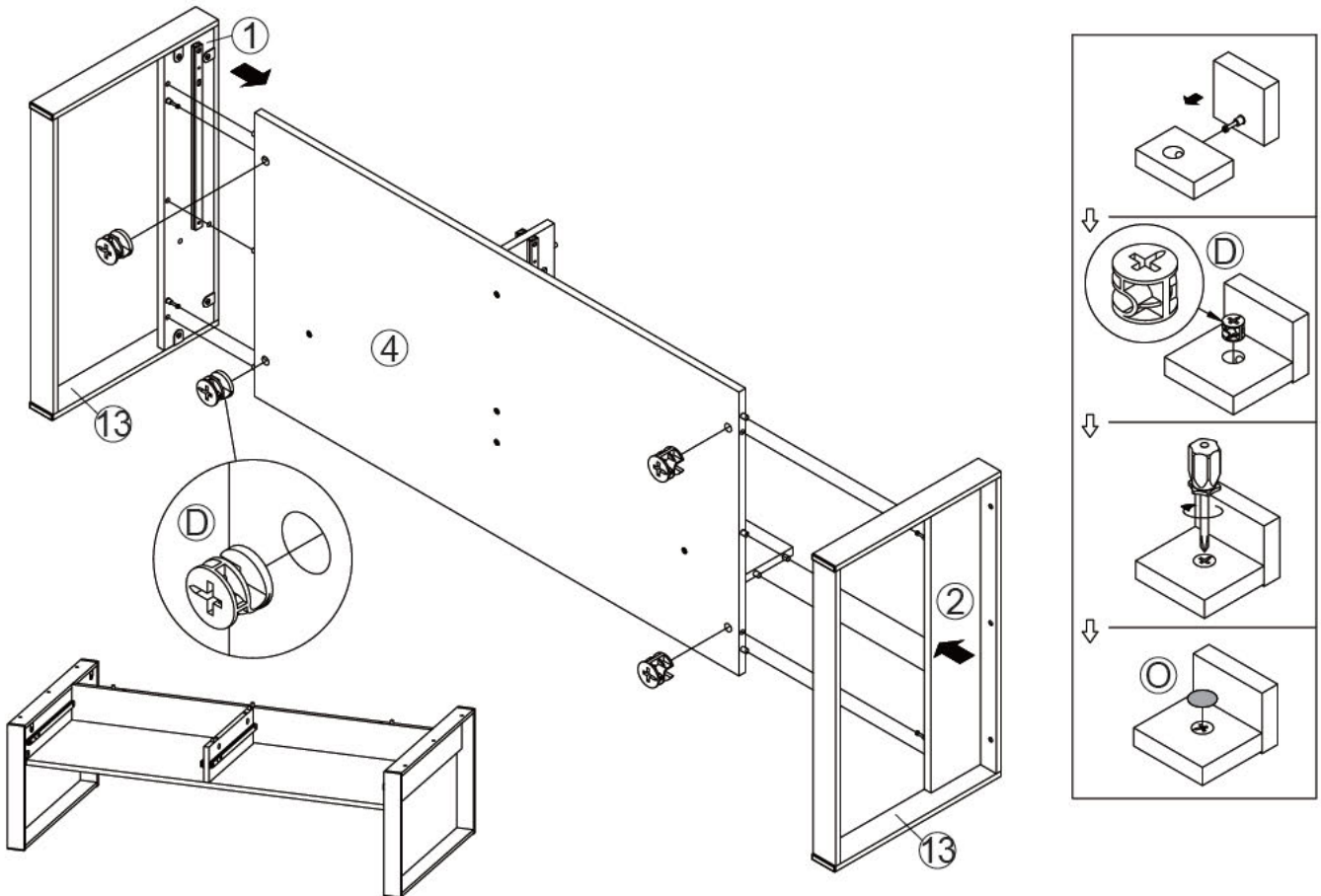

7

C
4x



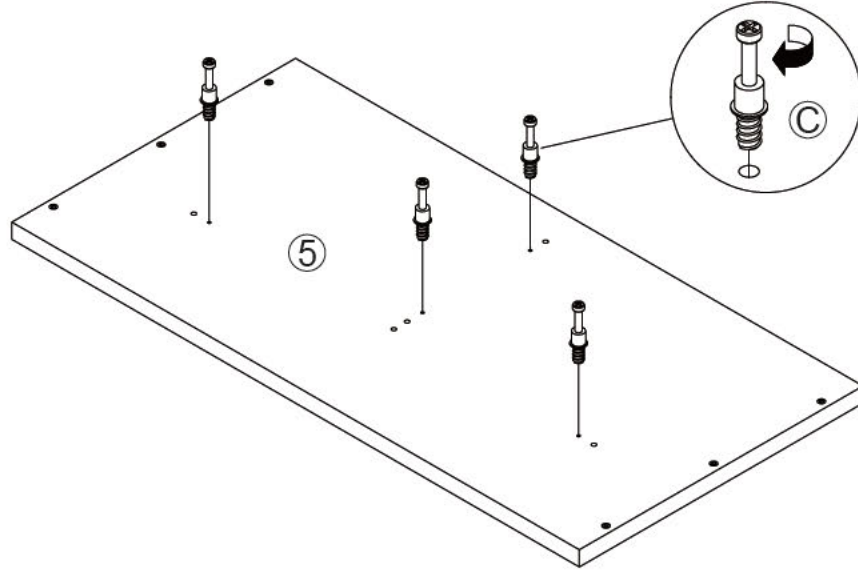



8

A D L M O M4

LEIM/GLUE 4x 6x 1x 4x

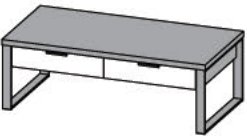
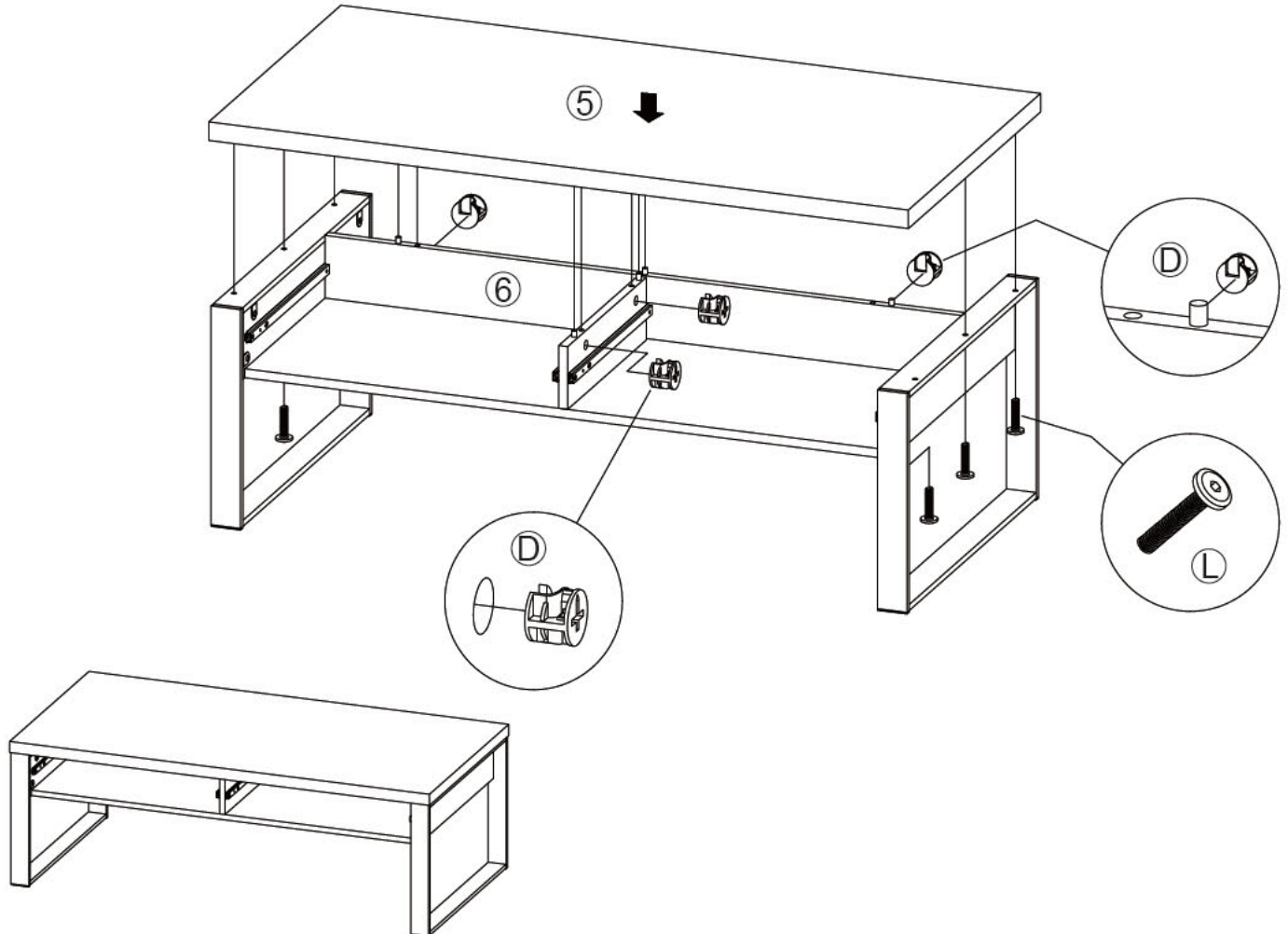
9	A	B	C	F	H	J	K	O		
	LEIM/GLUE	4x	4x	8x	4x	2x	4x	4x		

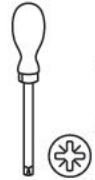
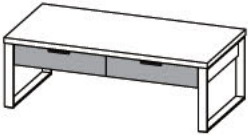

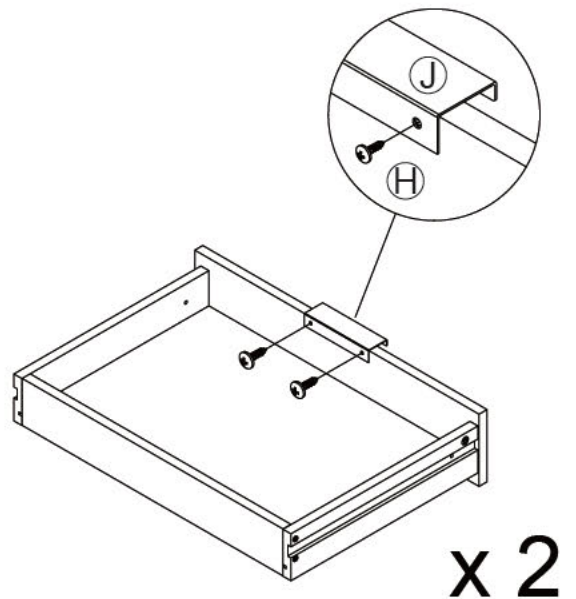
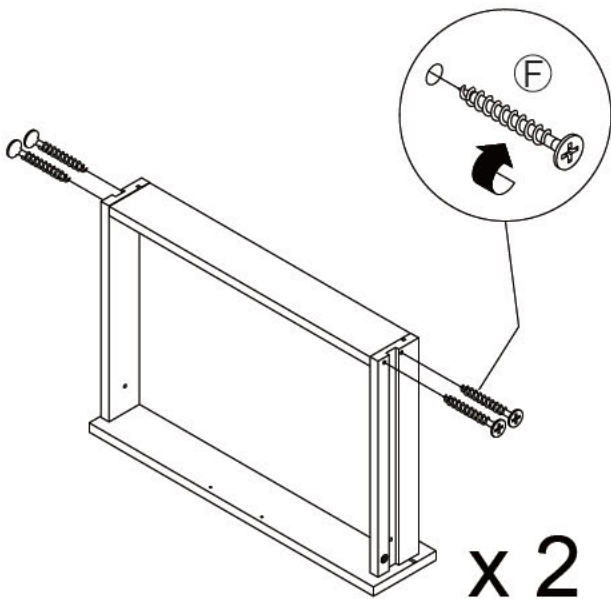
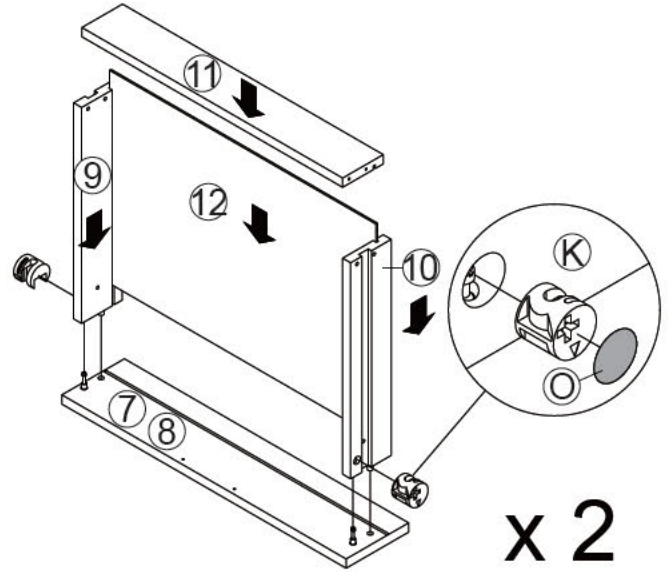
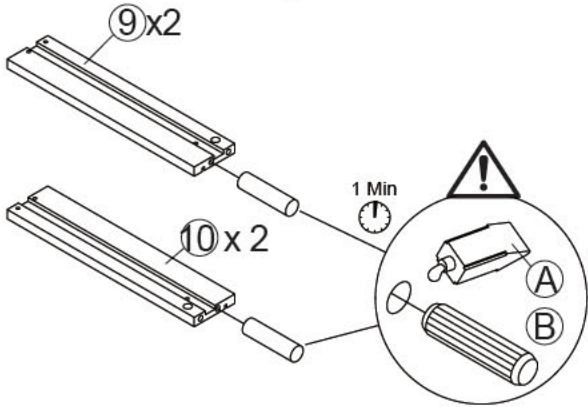
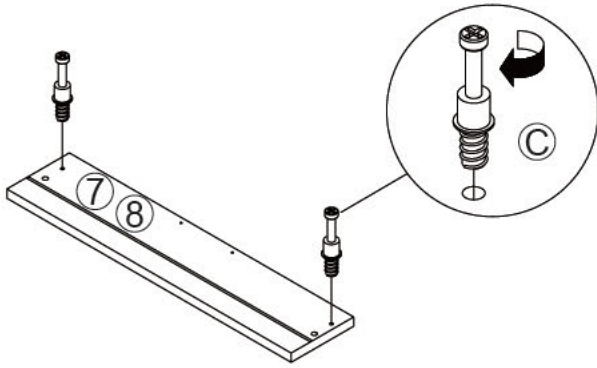
10

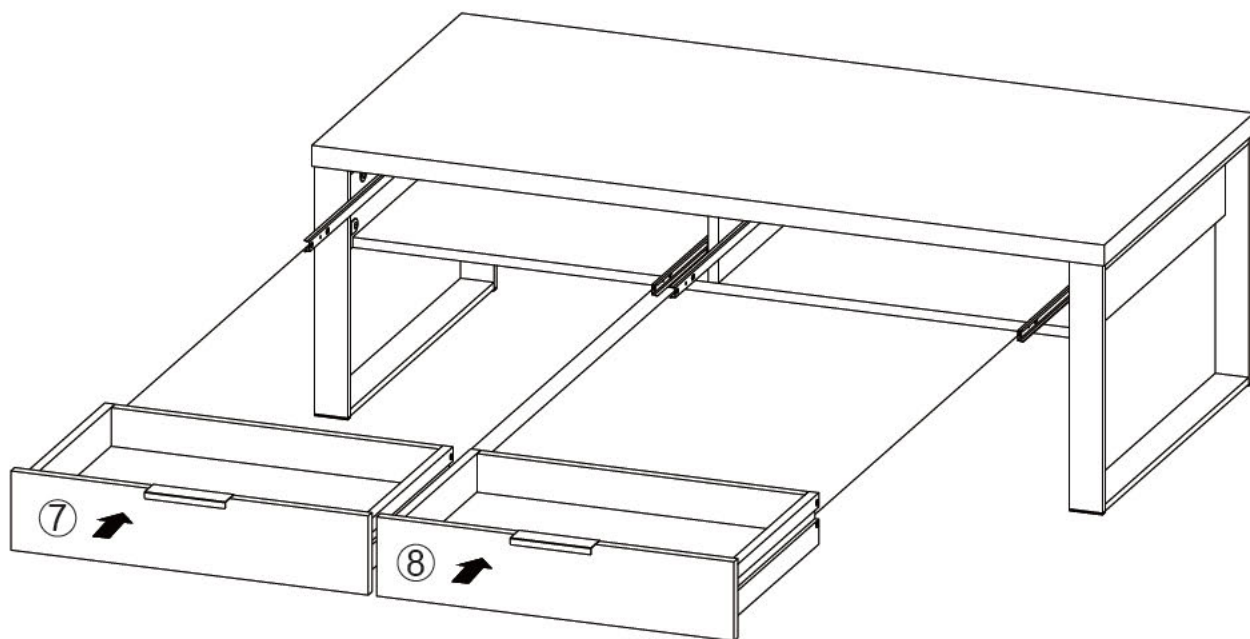
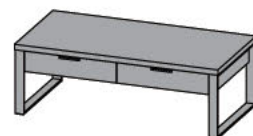

11

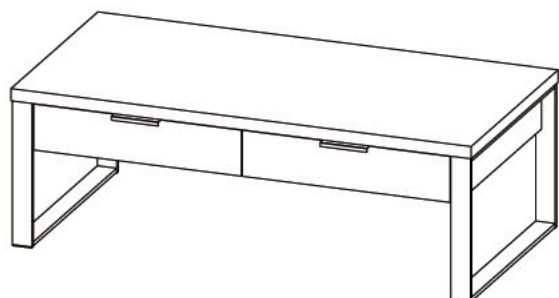
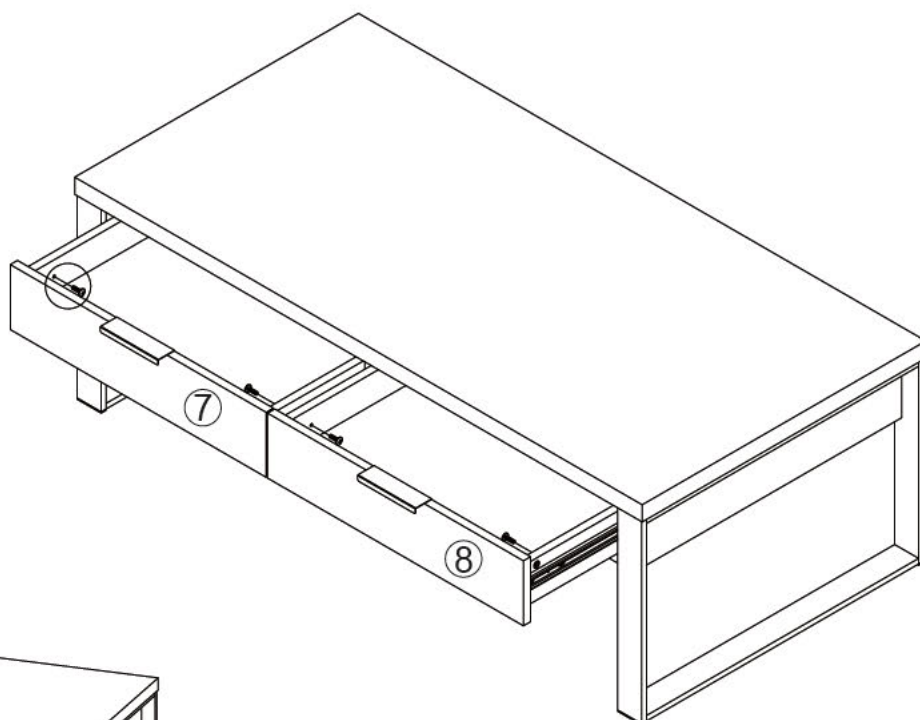
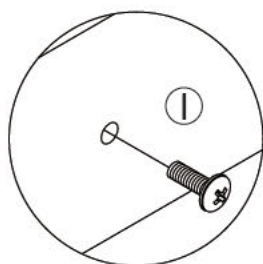
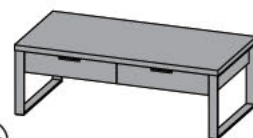
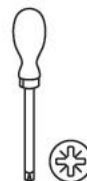

Caring your new furniture!

Caring instructions | Pflegehinweise | Instructions d'entretien | Instrucciones de cuidado | Istruzioni per la cura | Pokyny pro péči | Bakım talimatları | Инструкции по уходу

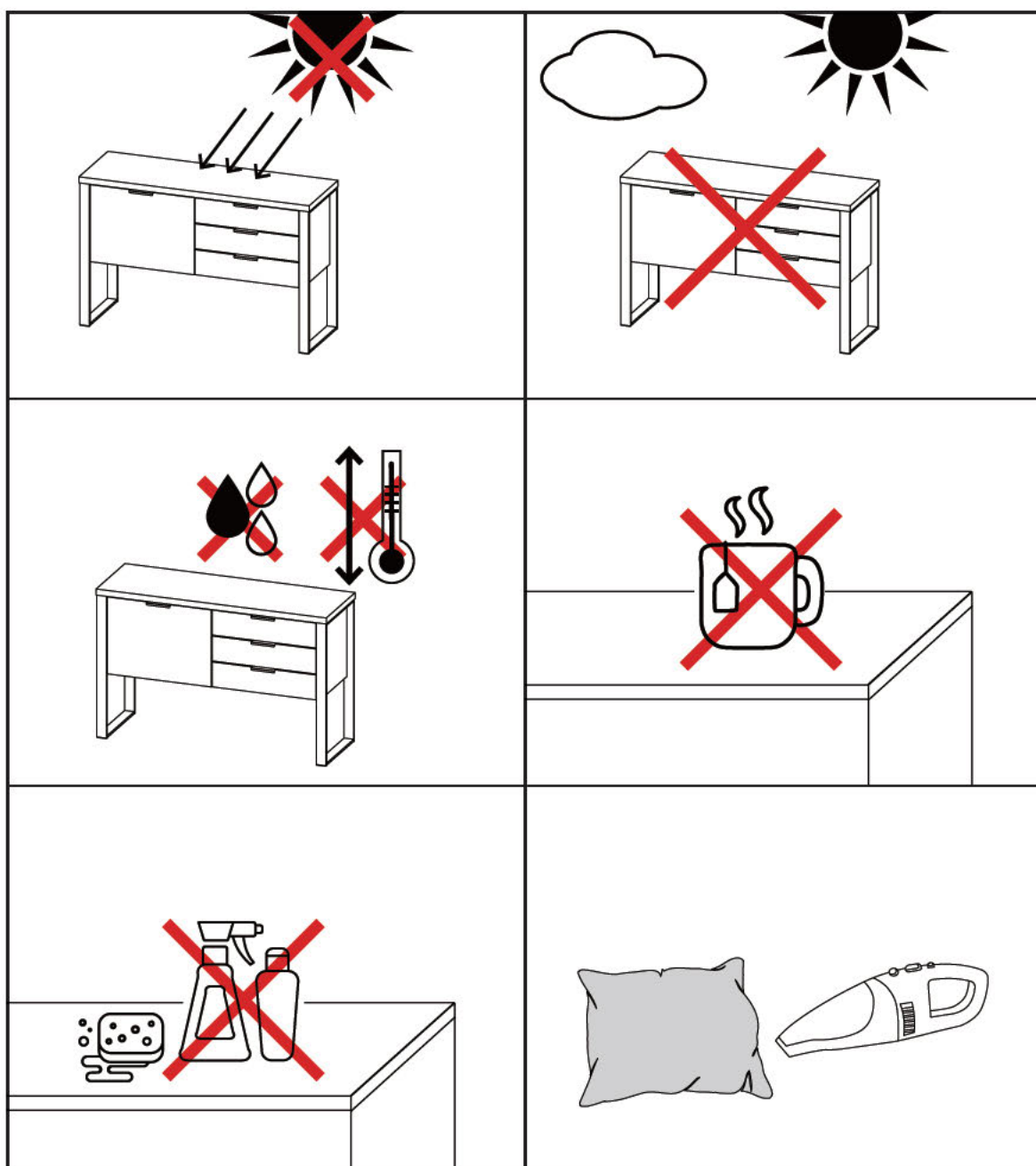

ENGLISH | CARING INSTRUCTIONS

- Protect your furniture from direct sunlight, extreme light exposure, and heat. The materials and surfaces may fade.
- Do NOT use this furniture outdoors.
- Do NOT expose this furniture to high levels of humidity and ensure a stable temperature.
- Do NOT place hot objects directly on the surfaces.
- Clean wood, metal, and glass surfaces with slightly damp cloth only and wipe dry immediately. Do NOT use any strong cleaning agents or detergents.
- Gently vacuum upholstered furniture. NEVER use strong detergents or bleach.
- To reduce signs of wear and tear, regularly flip over upholstery/ cushions, if they are reversible.

FRANÇAIS | CONSEILS D'ENTRETIEN :

- Protégez vos meubles contre la lumière directe du soleil, ainsi que contre l'exposition extrême à la lumière et à la chaleur. Les tissus et les surfaces peuvent se décolorer.
- NE PAS utiliser ce meuble à l'extérieur.
- NE PAS exposer à une forte humidité et maintenir la température stable.
- NE PAS poser des objets chauds directement sur la surface.
- Nettoyer les surfaces en bois, en métal et en verre uniquement avec un chiffon légèrement humide, puis les essuyer immédiatement. NE PAS utiliser d'agents de nettoyage ou de détergents agressifs.
- Aspirez doucement les meubles rembourrés. NE JAMAIS utiliser de détergents puissants ou d'eau de Javel.
- Afin de réduire les marques d'usure, tourner régulièrement le rembourrage/les coussins, s'ils sont réversibles.

ITALIANO | ISTRUZIONI PER LA CURA

- Proteggere il mobile dalla luce diretta del sole, dalla luce estrema e dal calore. I tessuti e le superfici possono sbiadire.
- NON utilizzare questi mobili all'esterno.
- NON esporre questi mobili a umidità eccessiva e garantire una temperatura stabile.
- NON posizionare oggetti caldi direttamente sulle superfici.
- Pulire le superfici in legno, metallo e vetro solo con un panno leggermente umido, asciugare immediatamente. NON utilizzare detersivi o detergenti aggressivi.
- Aspirare delicatamente i mobili imbottiti. Non utilizzare MAI detergenti aggressivi o candeggina.
- Per ridurre i segni di utilizzo, girare regolarmente il rivestimento/i cuscini, a condizione che siano reversibili.

TÜRKÇE | BAKIM UYARILARI

- Mobilyalarınızı doğrudan güneş ışığına, aşırı ışık etkisine ve ısıya karşı koruyun. Kumaşlar ve yüzeyler solabilir.
- Bu mobilyayı açık alanda KULLANMAYIN.
- Bu mobilyayı yüksek hava nemine maruz BIRAKMAYIN ve stabil bir sıcaklık sağlayın.
- Sıcak cisimleri doğrudan yüzeyin üzerine BIRAKMAYIN.
- Ahşap, metal ve cam yüzeyleri sadece hafif nemlendirilmiş bir bezle temizleyin, hemen ardından da kurulayın. Aşındırıcı temizleme maddeleri ve deterjanlar KULLANMAYIN.
- Kumaş kılıflı süngerli mobilyaların hafifçe tozunu emdirin. Asla aşındırıcı deterjanlar veya ağartıcılar kullanmayın.
- Kullanımdan kaynaklanan izleri azaltmak için çevrilebiliyorlarsa, süngerleri/yastıkları düzenli olarak çevirin.

DEUTSCH | PFLEGEHINWEISE

- Schütze Dein Möbel vor direkter Sonneneinstrahlung, extremer Licht einwirkung und Hitze. Stoffe und Oberflächen können ausbleichen.
- Benutze dieses Möbel NICHT im Außenbereich.
- Setze dieses Möbel NICHT zu hoher Luftfeuchtigkeit aus und Sorge für eine stabile Temperatur.
- Heiße Gegenstände NICHT direkt auf die Oberflächen stellen.
- Holz, Metall und Glasoberflächen nur mit leicht feuchtem Tuch reinigen, sofort trocken nachwischen. Benutze KEINE scharfen Putz- oder Reinigungsmittel.
- Polstermöbel sanft absaugen. NIEMALS scharfe Reinigungsmittel benutzen oder Bleichmittel einsetzen.
- Um Gebrauchsspuren zu reduzieren, wende die Polster/Kissen regelmäßig, sofern diese wendbar sind.

ESPAÑOL | INDICACIONES DE CUIDADO

- Protege el mueble de la radiación solar directa, de una exposición intensa a la luz y del calor. Los tejidos y las superficies pueden perder el color.
- NO uses este mueble en exteriores.
- NO expongas este mueble a una humedad alta y garantiza que haya una temperatura estable.
- NO pongas objetos calientes directamente sobre las superficies.
- Limpia las superficies de madera, metal y cristal solo con un paño ligeramente humedecido y después con un paño seco. NO uses productos de limpieza o detergentes agresivos.
- Pasa la aspiradora suavemente a los muebles tapizados. NO uses nunca detergentes agresivos ni blanqueadores.
- Para reducir las marcas de uso, da la vuelta regularmente a los cojines/acolchado, siempre que sea posible darles la vuelta.

ČEŠTINA | POKYNY PRO PÉČI

- Nevystavujte nábytek přímému slunečnímu záření ani extrémnímu světlu a horku. Textilie a povrchy mohou vyblednout.
- NEPOUŽÍVEJTE nábytek venku.
- NEVYSTAVUJTE nábytek příliš vysoké vlhkosti vzduchu a udržujte v jeho okolí stabilní teplotu.
- NEPOKLÁDEJTE horké předměty přímo na povrch nábytku.
- Dřevěné, kovové a skleněné povrchy čistěte pouze mírně navlhčeným hadříkem a ihned otřete do sucha. NEPOUŽÍVEJTE žádné agresivní čisticí prostředky.
- Čalouněný nábytek s textilním potahem opatrně vysajte. NIKDY nepoužívejte ostré čisticí prostředky nebo bělidla.
- Pokud chcete zredukovat známky opotřebení, doporučujeme čalounění/polštáře pravidelně obracet, je-li to možné.

РУССКИЙ | ИНСТРУКЦИИ ПО УХОДУ

- Предохраняйте свою мебель от прямых солнечных лучей, сильного света и нагревания. Материалы и поверхности могут обесцвечиваться.
- НЕ используйте эту мебель вне помещения.
- НЕ подвергайте эту мебель воздействию чрезмерной влажности и обеспечьте стабильную температуру.
- НЕ кладите горячие предметы прямо на поверхности.
- Протрите деревянные, металлические и стеклянные поверхности слегка влажной тряпкой и сразу же вытрите насухо. НЕ используйте агрессивные чистящие или моющие средства.
- Мягкую мебель с текстильным покрытием аккуратно пропылесосьте. НИ В КОЕМ СЛУЧАЕ не используйте агрессивные моющие средства или отбеливатели.
- Чтобы уменьшить признаки старения, регулярно переворачивайте подушки/валики, если они двусторонние.

ENGLISH

Something's not OK? We'd be happy to help!

We design our quality products with our hearts, create them with our brains, and manufacture and test them with attention to detail. However, should we nevertheless make a mistake, please contact us. Please be sure to send us the Service Card with the information provided so that we can process your request as quickly as possible.

FRANÇAIS

Un problème ? Nous sommes à votre service !

Nos produits de qualité sont conçus et testés avec passion, intelligemment et avec soin. Si vous deviez toutefois constater un problème, veuillez nous contacter. Veuillez nous envoyer la carte d'assistance avec les informations données afin que nous puissions traiter votre demande dans les plus brefs délais.

ITALIANO

Qualcosa non va? Siamo a tua disposizione!

I nostri prodotti di qualità sono disegnati con il cuore, progettati con comprensione, realizzati e testati con attenzione ai dettagli: se, tuttavia, ci fosse sfuggito un errore, contattaci. Inviaci la scheda di servizio con le informazioni fornite in modo da poter elaborare la tua richiesta il più rapidamente possibile.

TÜRKÇE

Bir sorun mu var? Memnuniyetle yardımcı oluruz!

Kalite ürünlerimiz tüm kalbimizle tasarlandı, anlayışla geliştirildi, ayrıntılı sevgiyle üretildi ve kontrol edildi - Buna rağmen bir hata yapılmışsa bizimle iletişime geçin. Bunun için sorununu en kısa zaman işleme alabilmemiz için belirtilen bilgilerle birlikte servis kartını bize gönderin.

DEUTSCH

Etwas nicht OK? Wir helfen gern!

Unsere Qualitätsprodukte werden mit Herz designt, mit Verstand entworfen, mit Detailliebe hergestellt und geprüft. Sollte uns trotzdem ein Fehler unterlaufen sein, so bitten wir um Kontaktaufnahme. Sende uns dazu die Service Card mit den angegebenen Informationen, damit wir Dein Anliegen schnellstmöglich bearbeiten können.

ESPAÑOL

¿Algo no está bien? ¡Te ayudamos con mucho gusto!

Nuestros productos de calidad están diseñados con el corazón, planificados con la cabeza, fabricados prestando atención al detalle y probados. Si, a pesar de todo, hubiera algún fallo, contacta con nosotros. Envíanos la tarjeta de servicio rellena para que podamos tramitar tu petición con la mayor brevedad.

CZECH

Něco není v pořádku? Rádi vám pomůžeme!

Naše kvalitní výrobky koncipujeme srdcem, navrhujeme rozumem a vyrábíme a testujeme s velkou pečlivostí. Pokud jsme se přesto dopustili chyby, prosíme vás, abyste se na nás obrátili. Pošlete nám prosím servisní kartu s uvedenými informacemi, abychom váš požadavek mohli co nejdříve zpracovat.









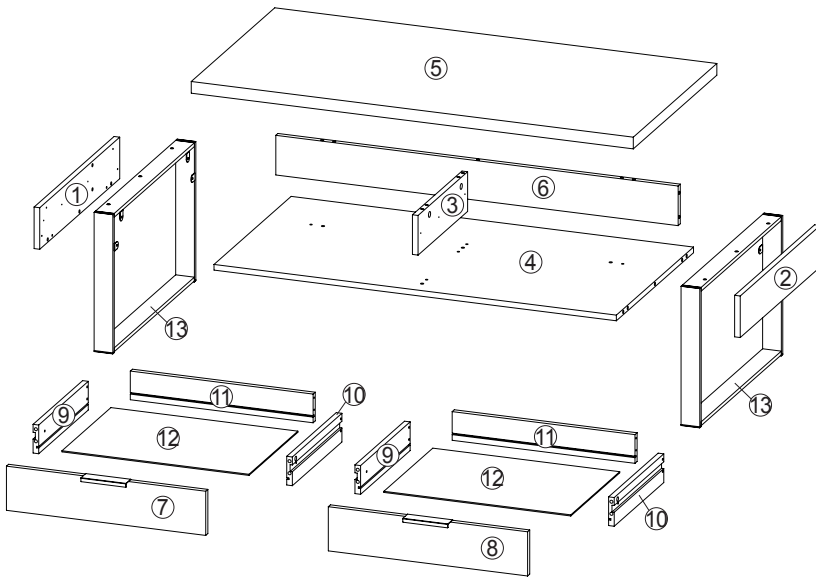



РУССКИЙ

Что-нибудь не в порядке? Мы будем рады помочь!

Наши качественные изделия разрабатывались с большим старанием и душой, изготавливались и проверялись с вниманием к деталям. Но если мы все же допустили ошибку, свяжитесь с нами. Для этого отошлите нам сервисную карту, указав необходимую информацию, чтобы мы могли как можно быстрее обработать ваш запрос.

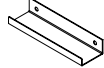
Service Card



A 	B 	C 	D 
E 	F 	G 	H 
I 	J 	K 	L 
M 	N 	O 