

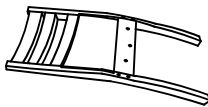



ASSEMBLY INSTRUCTIONS

Thank you for purchasing this quality product. Be sure to check all packaging materials carefully for small parts that may have come loose inside the carton during shipment.

"Hardware is attached underneath the seat bottom"

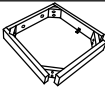
Components List :

NO.	DESCRIPTION	SKETCH	QTY
A	Back Rest		1 PC
B	Cushion Seat		1 PC
C	Seat Frame		1 PC
D	Front Leg		2 PCS

Hardware List:

NO.	DESCRIPTION	SIZE	SKETCH	QTY
1	Allen Key	4mm		1 PC
2	Long Bolt with washers	M6X80mm		4 PCS
3	Short Bolt with washers	M6X40mm		3 PCS
4	Medium Bolt with washers	M6X60mm		4 PCS

Reminders

1. Use only the hardware supplied.
2. Once the chair is finished, level and tighten all the bolts.
3. Do not over-tighten bolts.
4. This item may require periodic tightening.

NOTE:

1. Hardware pack is located underneath the Cushion Seat with Frame (B).
2. Two or more people are needed for assembly. Please keep all hardware parts out of reach of children.

STEP 1

Attach Cushion Seat With Seat Frame (B & C) to Back Rest (A) using Short Bolt with washers (3) and Long Bolt with washers (2), tighten using Allen Key (1)

STEP 2

Align & fasten Front Leg (D) to Seat Frame (C) using Medium Bolt with washers (4) and tighten with Allen Key (1).

Assembly is now complete.

Thank you for purchasing this product.

