

6 - Drawer Dresser

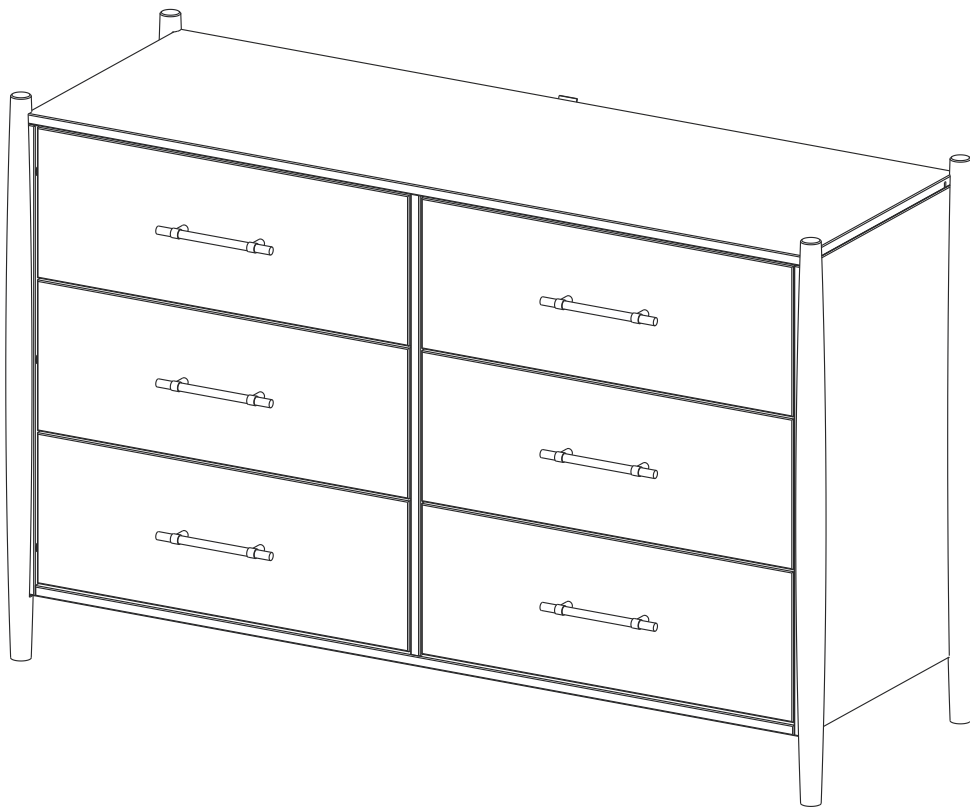

For Residential Use Only

Time to get started

Set up a clean and soft workplace to avoid damage during assembly. You can use the box and internal protections as a cover. It also helps to double-check if you have got all the pieces and parts before diving into the assembly.

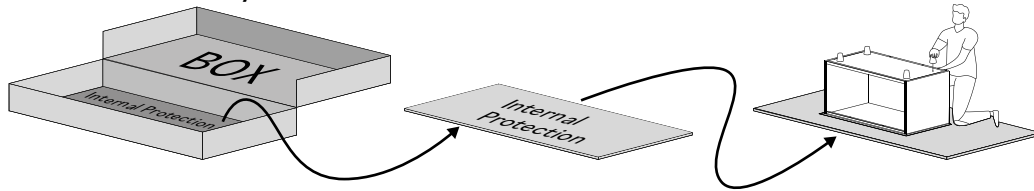

**Estimated time
for assembly**

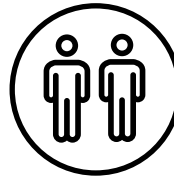

2 People Build

**People recommended
for assembly**

Make it a team effort!
Grab a friend for quicker,
easier assembly.

Tools Needed

Grab a Phillips head screwdriver and a hammer to conquer this assembly.

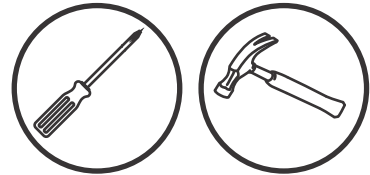

Use power tools with caution

This furniture is made of Solid Wood and Composite Wood, soft materials. If you choose to use power tools, set it to the slower setting. Be careful! Power tools can cause cracking or damage to the furniture, they can also damage the hardware if misused.

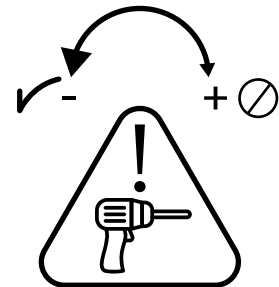

Parts List







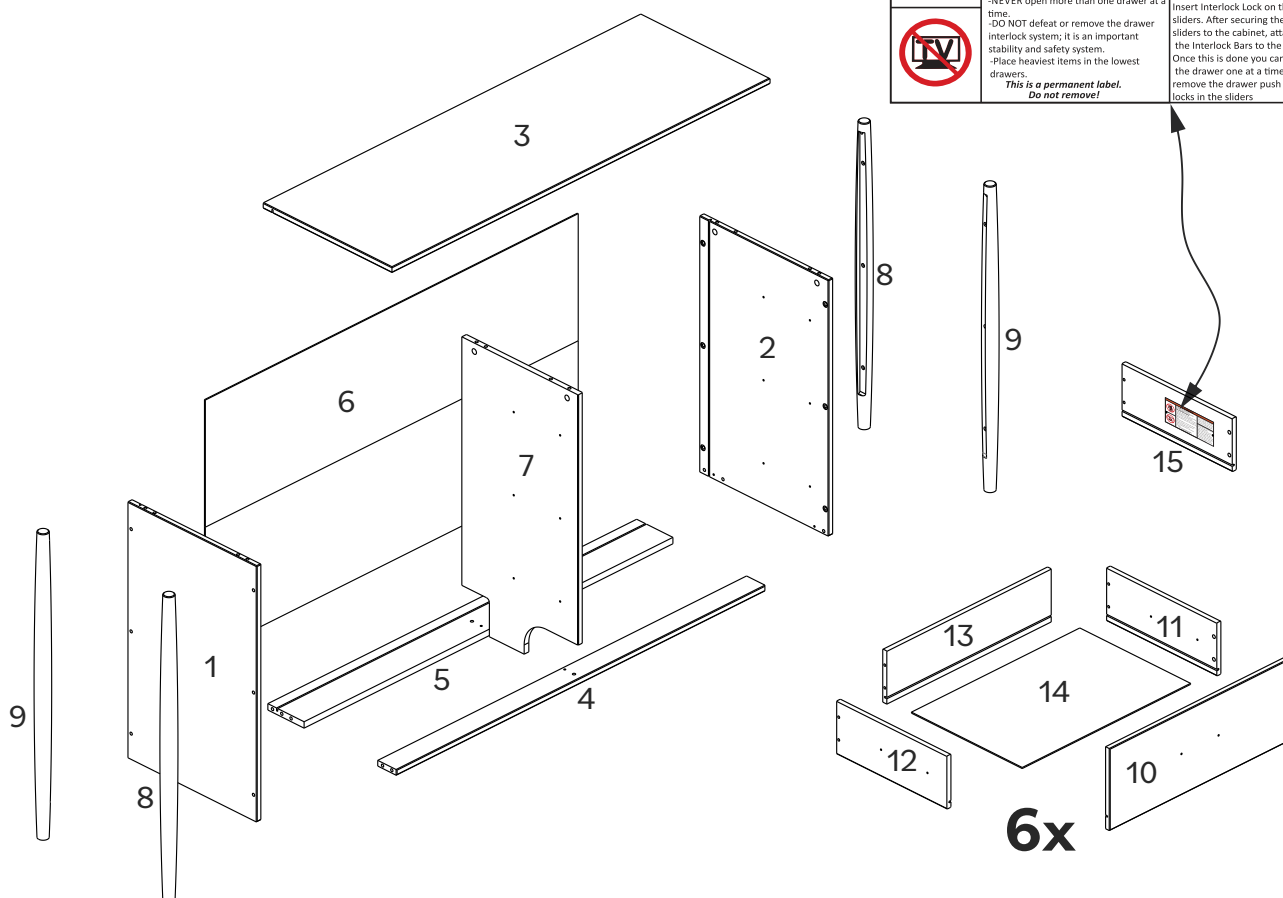





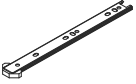

Part Number	Description	Quantity
1	Left Panel	1
2	Right Panel	1
3	Top Panel	1
4	Front Rail	1
5	Back Rail	1
6	Back Panel	1
7	Center Panel	1
8	Left Foot	2
9	Right Foot	2
10	Drawer Front	6
11	Right Drawer Side	5
12	Left Drawer Side	6
13	Drawer Back	6
14	Drawer Bottom	6
15	Right Drawer Side With Warning	1

The drawer with the **WARNING LABEL**, have to be placed as the highest drawer.

⚠ WARNING		
	<p>Children have died from furniture tipover. To reduce the risk of furniture tipover:</p> <ul style="list-style-type: none"> -ALWAYS install anti tip device provided. -NEVER put a TV on this product. -NEVER allow children to stand, climb or hang on any drawers, doors, or shelves. -NEVER open more than one drawer at a time. 	<p>DO NOT remove the interlock system except for maintenance as shown. NEVER use the unit without the interlock installed following the instructions System Specific Instructions for Interlock Installation. Insert Interlock Lock on the sliders. After securing the sliders to the cabinet, attach the Interlock Bars to the Locks. Once this is done you can place the drawer one at a time. To remove the drawer push the locks in the sliders</p>
	<p>-DO NOT defeat or remove the drawer interlock system: it is an important stability and safety system.</p> <ul style="list-style-type: none"> -Place heaviest items in the lowest drawers. <p><i>This is a permanent label. Do not remove!</i></p>	

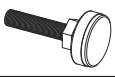
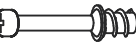

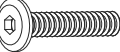





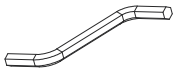

Hardware List

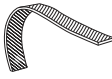
Part	Size	Name	Quantity
A		Dovetail	12
B		Dovetail Lock	24
C		Plastic Screw	24
D	 6x12mm	Screw	24
E		Interlock Lock	12
F	 3,5x30mm	Screw	12
G1	 250mm	Outer Slider	12
G2	 250mm	Inner Slider	12
H		Handle	6
I	 8x30mm	Wooden dowel	14
J		Leveling Bush	1
K		Leveling Foot	1
L	 6x31mm	Cam bolt	10
M	 15x11mm	Cam Lock	10
N		Interlock Bar	4
O	 7x35mm	Bolt	12
P	 4x40mm	Screw	3

*The hardware quantities listed above are required for proper assembly.
Extra hardware pieces may be included.*

Hardware List

Part	Size	Name	Quantity
Q		Hex Key	1
R		Wedge	14
S		Wall anchor	1
T		4x16mm Screw	1
U		6x35mm Plastic bush	1
V		Washer	2
X		6x14mm Screw	24
Z		3,5X14mm Screw	14

*The hardware quantities listed above are required for proper assembly.
Extra hardware pieces may be included.*

Introducing The Easy Assembly Drawer System

Say Goodbye to Assembly Hassle!

We understand that assembling drawers can be the most time-consuming and tedious part of putting together your new furniture. That's why we've developed the Easy Assembly Drawer System - to make the process easy!

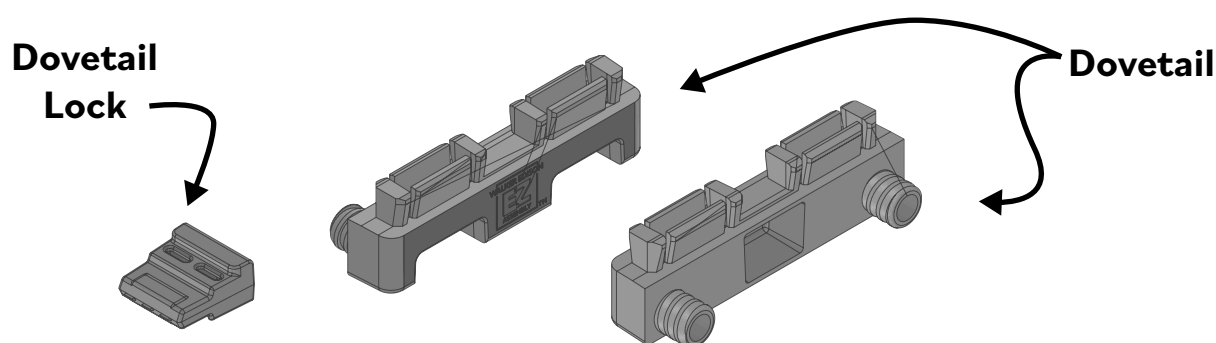

Why You'll Love Our Easy Assembly Drawer System:

Quick & Easy: Our new drawer hardware significantly reduces your assembly time. Get it done in no time!

Minimal Effort Required: Designed to be super simple, you'll need little to no tools to get the job done.

Built to Last: Strong and sturdy, our system ensures that your drawers stay solid and reliable.

Let's set the stage to assembly:

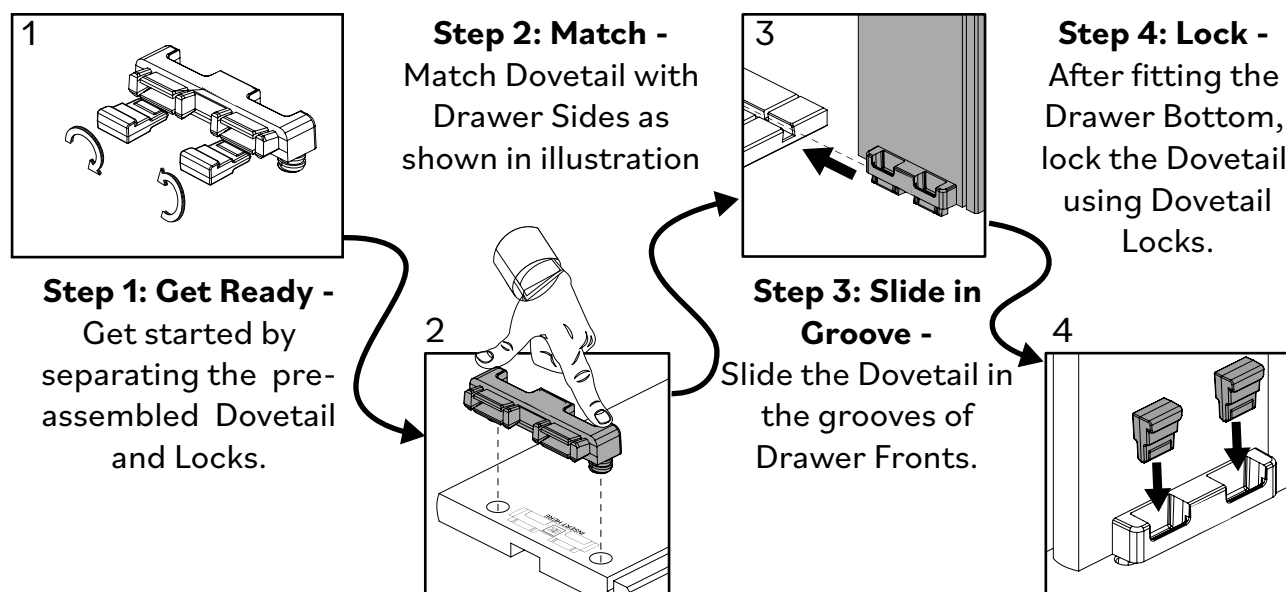

Attention: In the next steps there are more details to help you assemble.

Step 1

Prepare the Dovetails (A) by removing the Dovetail Locks (B) from the Dovetails (A).

1st

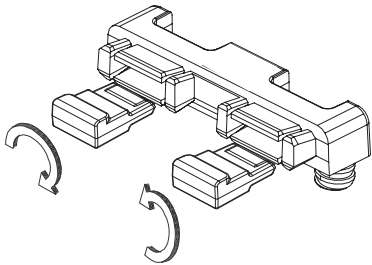

2nd

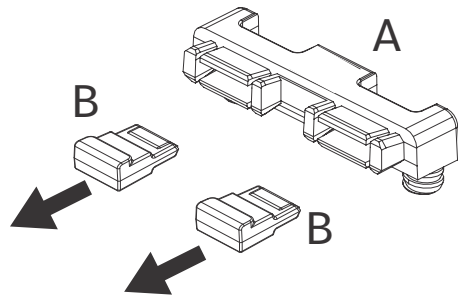

Step 2

Snap the Dovetails (A) into place on Right Drawer Sides (11 and 15) and Left Drawer Sides (12). Press the Dovetails until they are completely attached. Use a hammer if necessary.

Press the piece until it is completely attached

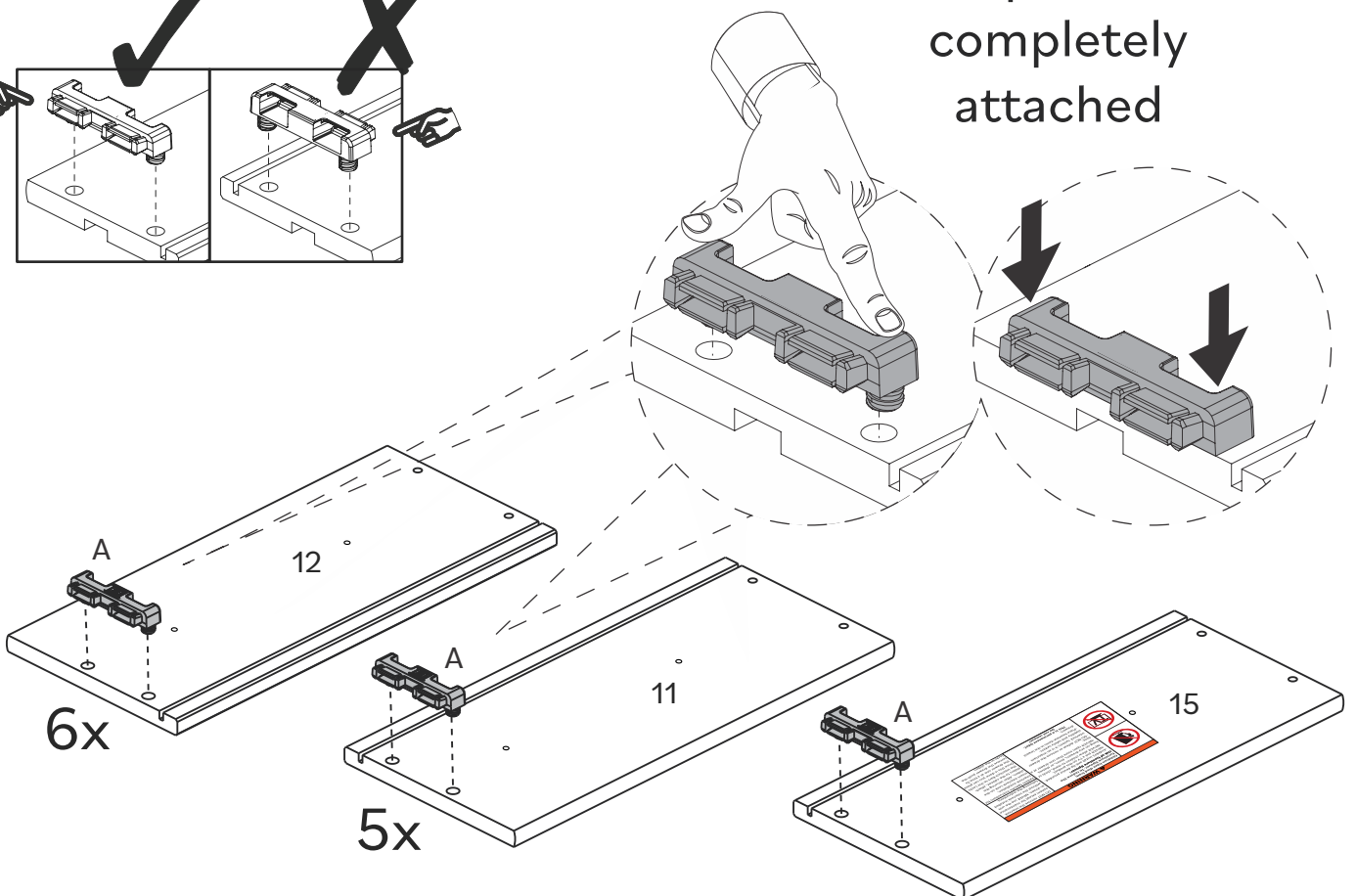
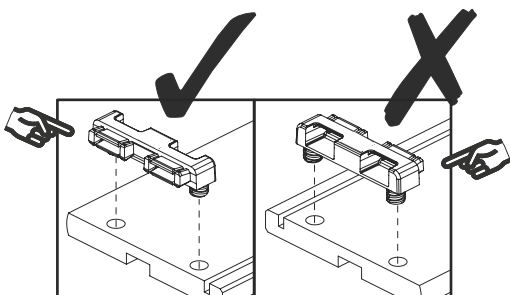

Step 3

Slide the Dovetail (A) on the Right Drawer Panel (11/15) and Left Drawer Panel (12) into the grooves on the Drawer Front (10).

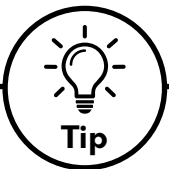
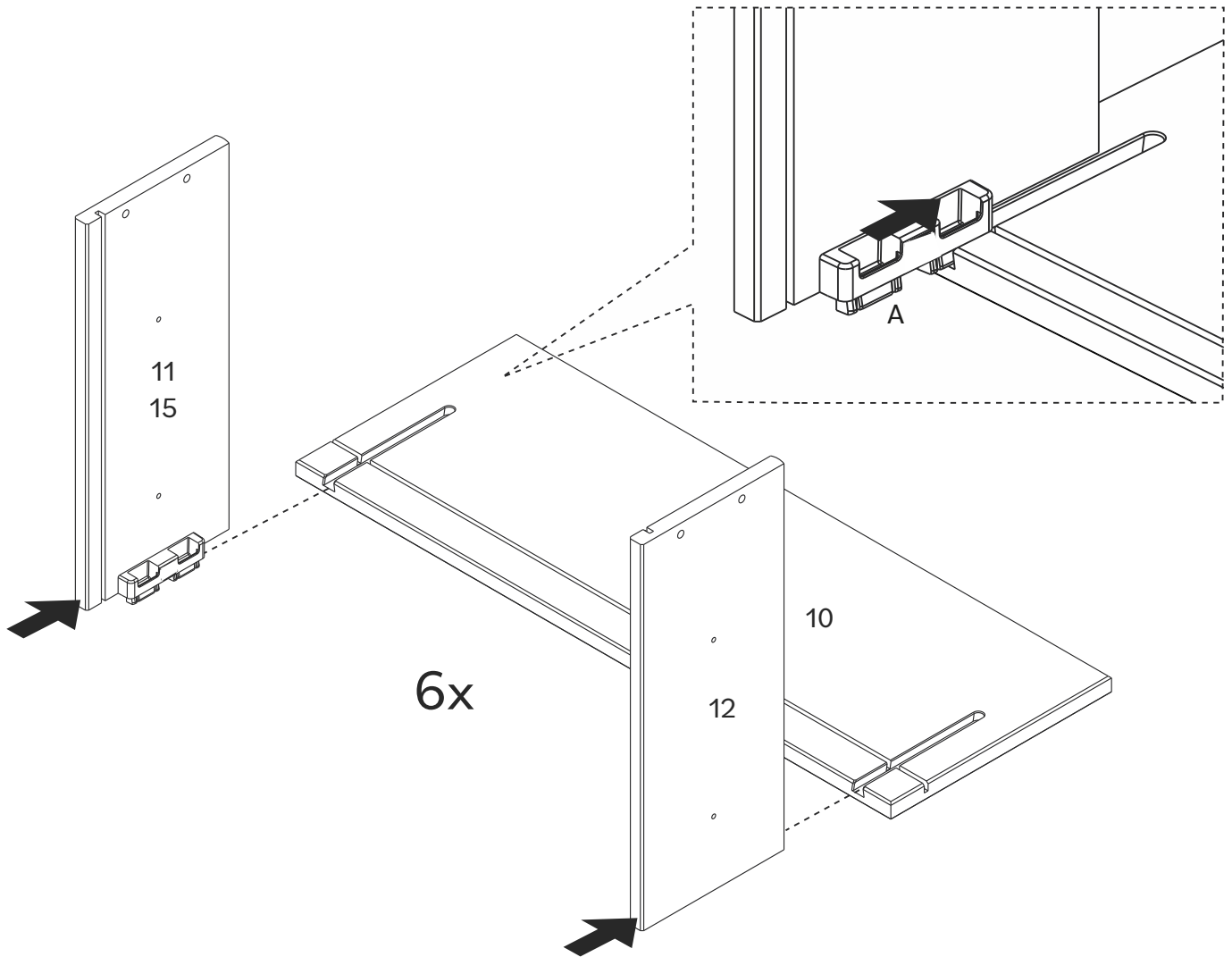

To keep your product looking its best and scratch-free, try assembling it on a soft surface like carpet or a blanket. This helps prevent any accidental scratches and keeps your furniture in top shape!

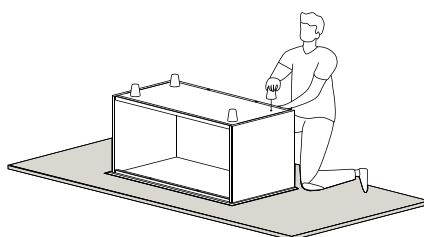

Step 4



Slide Drawer Bottom (14) between the grooves on Right Drawer Side (11 and 15) and Left Drawer Side (12) fitting in Drawer Front (10).

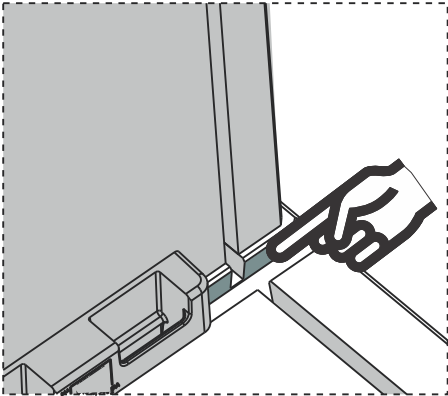

Align the grooves on the Drawer Sides and Drawer Front to receive the Drawer Bottom

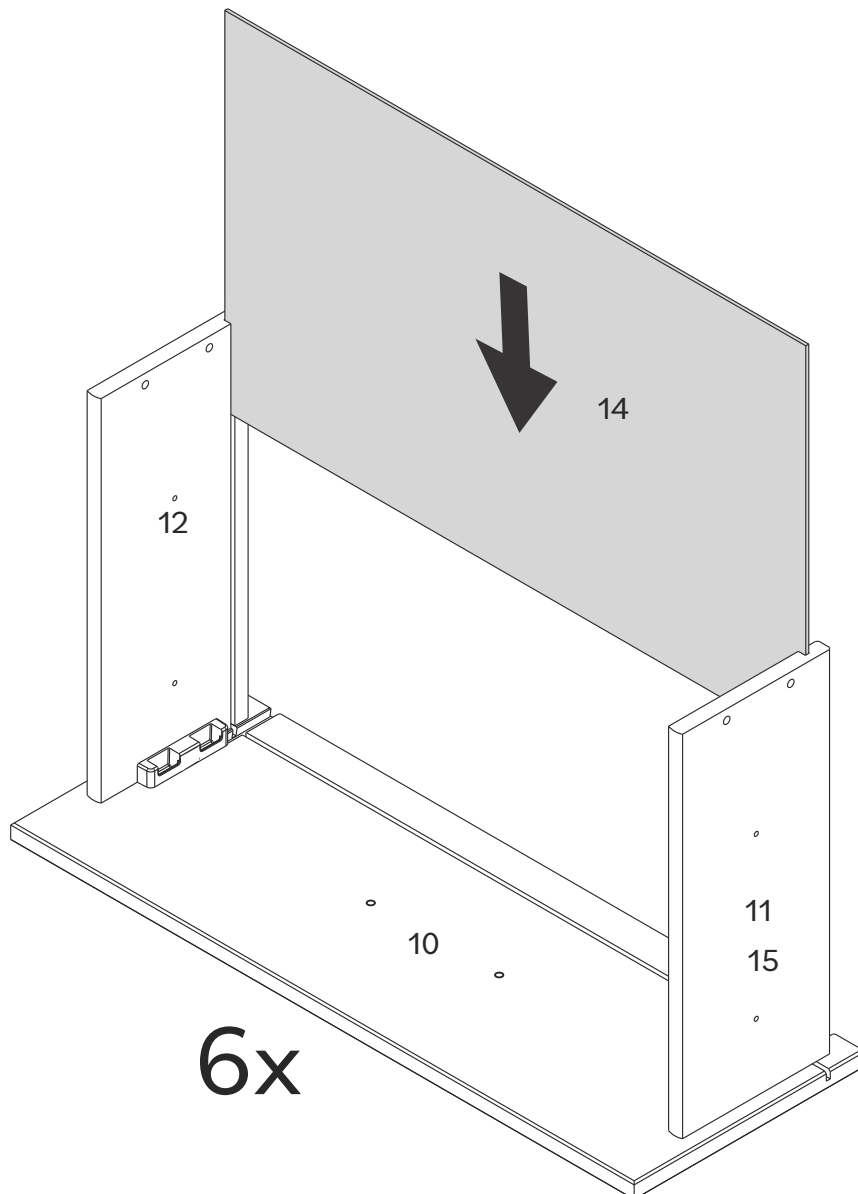

Step 5



To secure the Drawer sides, insert the Dovetail Locks (B) into the Dovetails (A). Use a hammer if necessary.

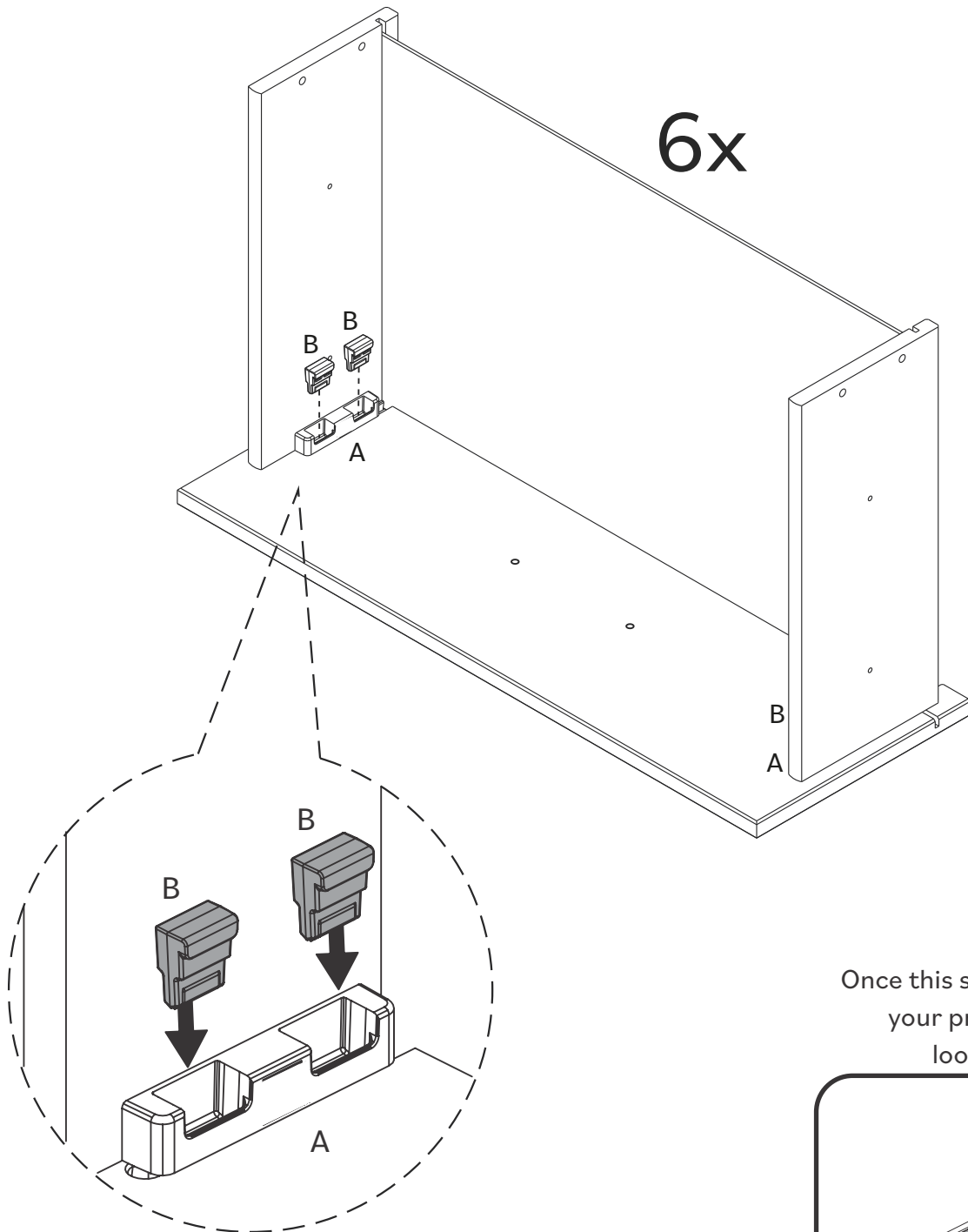

Once this step is completed,
your product should
look like this:

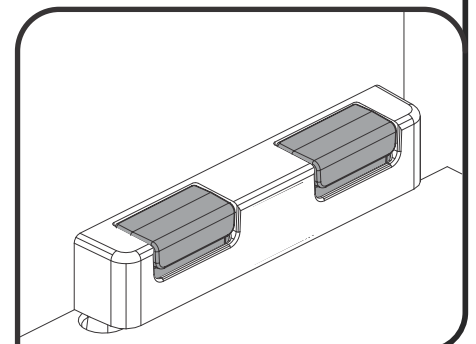

Step 6



Fit Drawer Bottom (14) to Drawer Back (13) and secure using Plastic Screw (C), you can insert it with your hands or using a hammer.

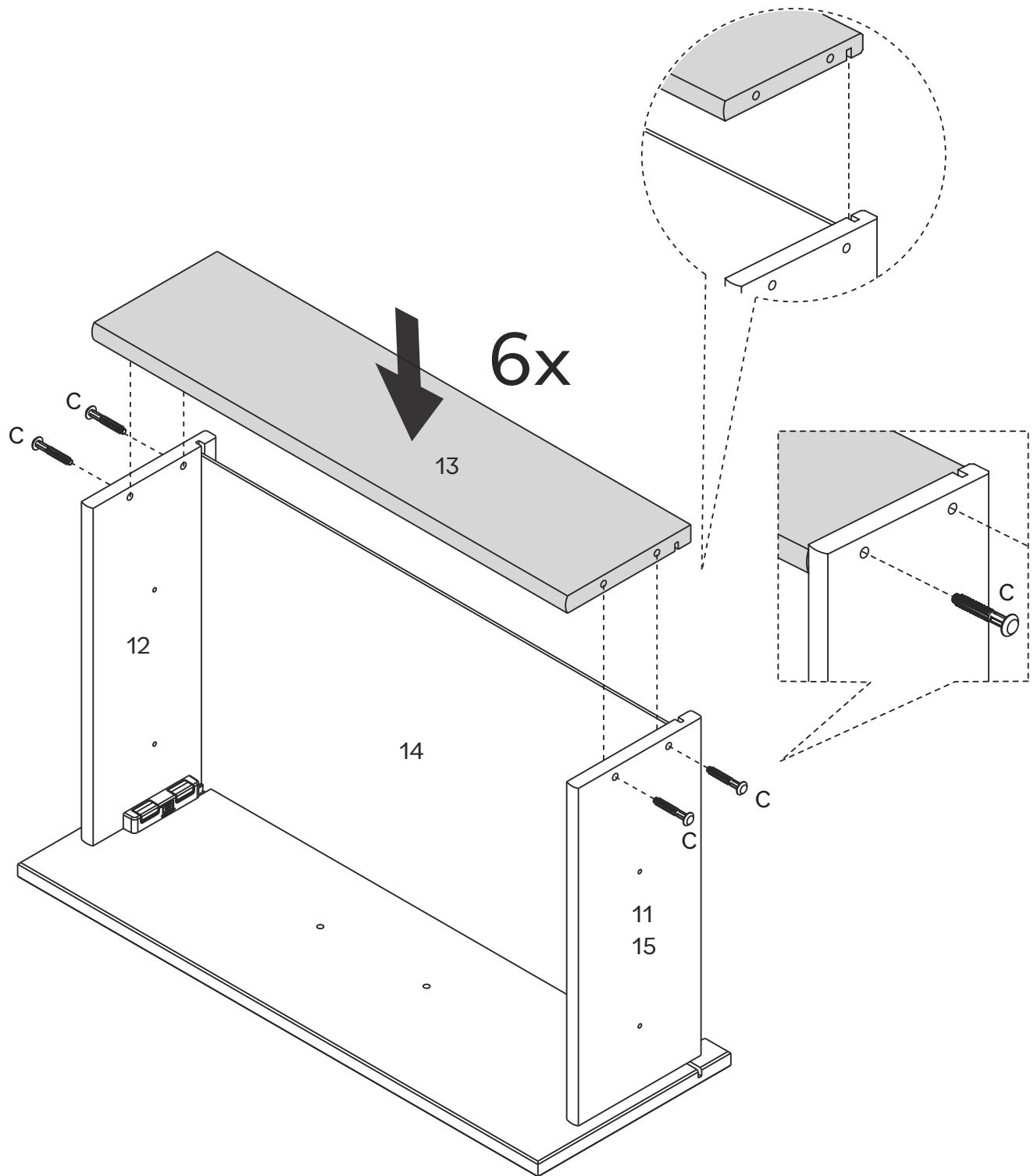

Step 7



Attach Inner Sliders (G2) to Right Drawer Sides (11 and 15) and Left Drawer Sides (12) using Screw (D) and a Phillips screwdriver.

Separate parts G1 and G2 by pressing the lock.

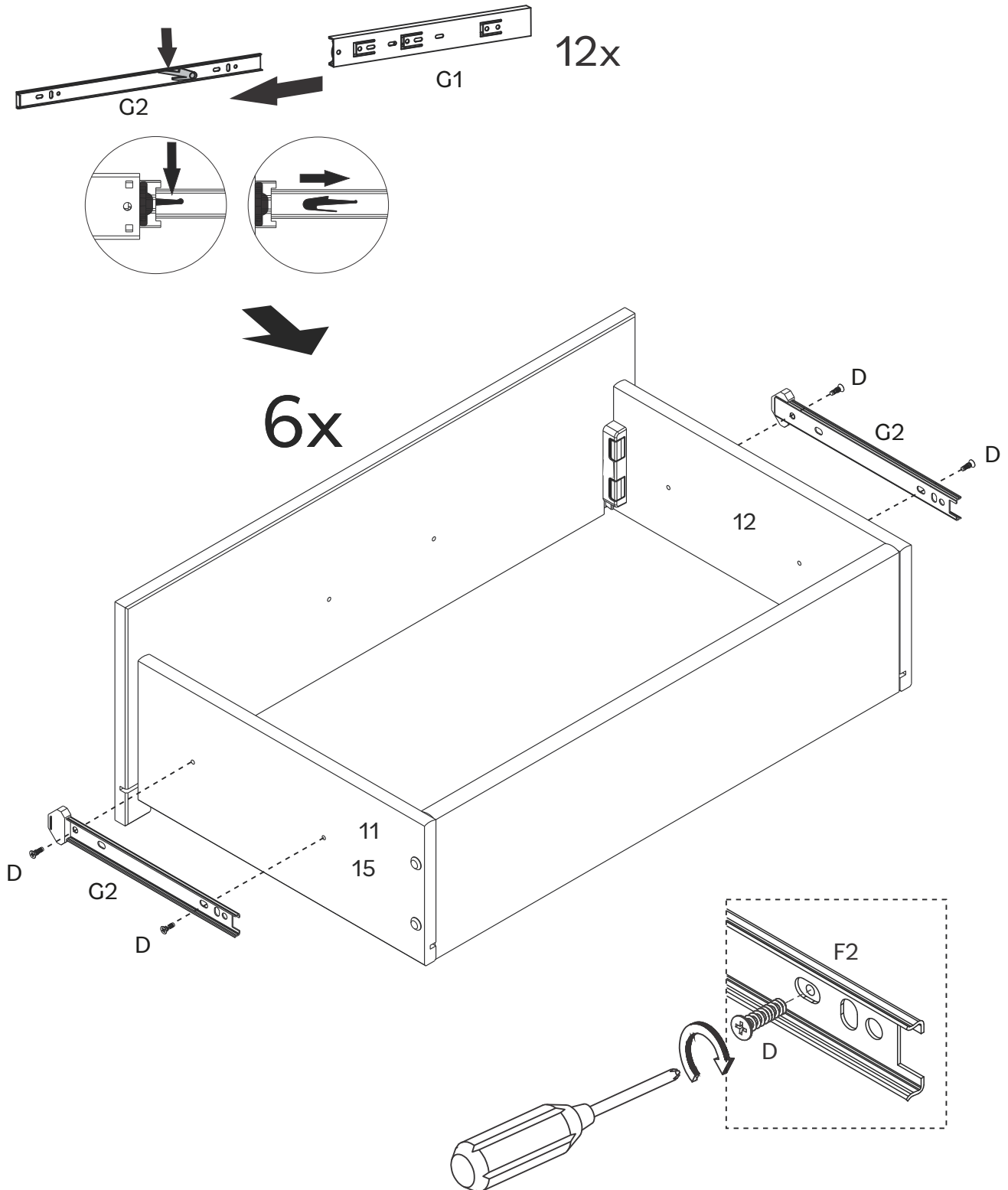

Step 8



Use Screws (F) and a Phillips screwdriver to secure Handles (H) to Drawer Fronts (10).

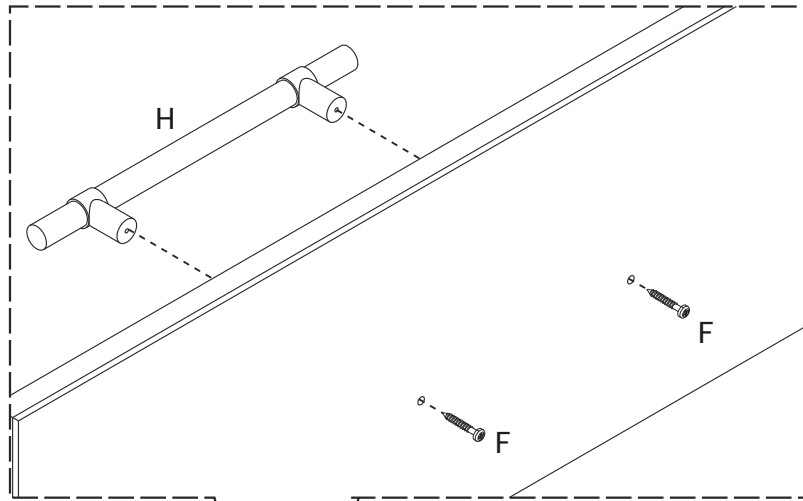

6x

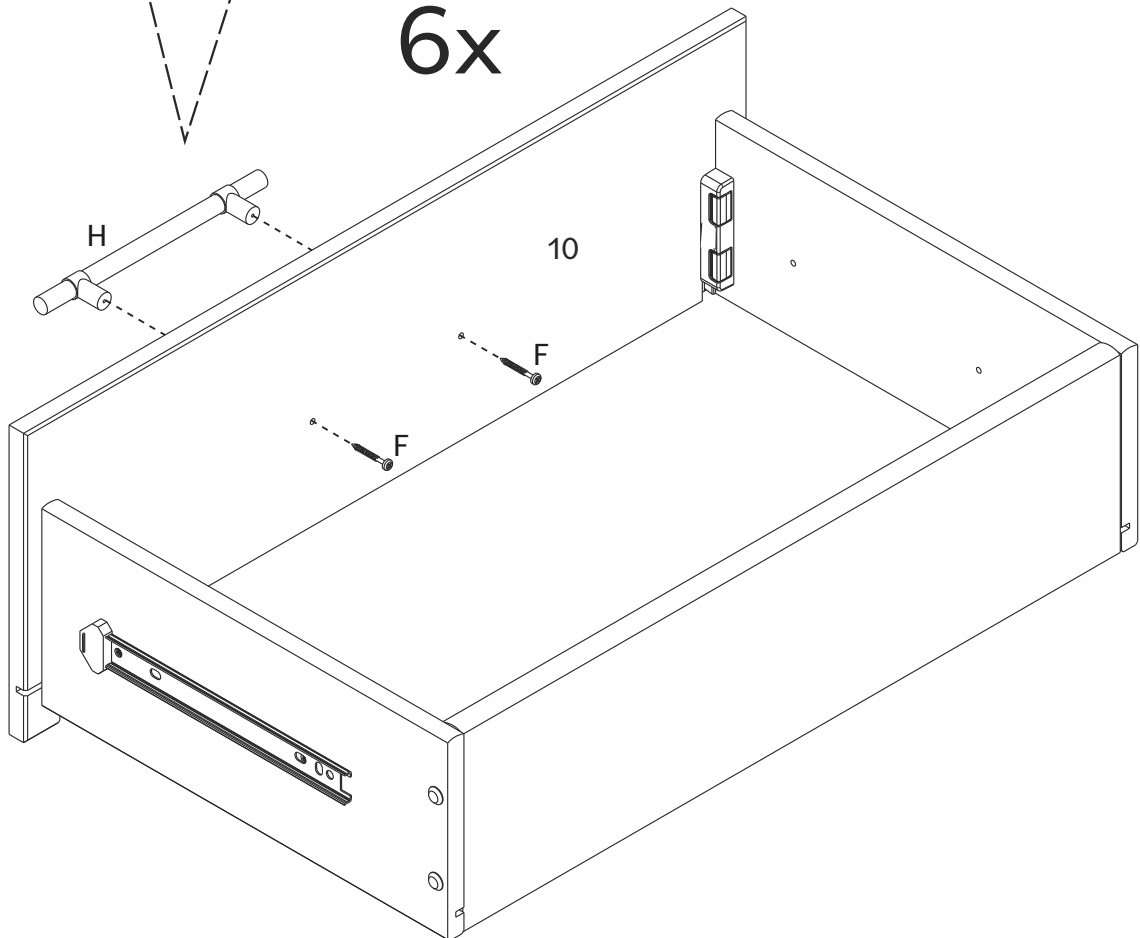

Step 9

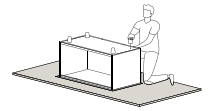

Insert Wooden Dowels (I) into Left Panel (1), Right Panel (2), Front Rail (4), Back Rail (5) and Center Panel (7). Also insert Leveling Bush (J) to Center Panel (7) and screw in Leveling Foot (K).

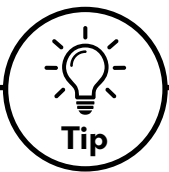
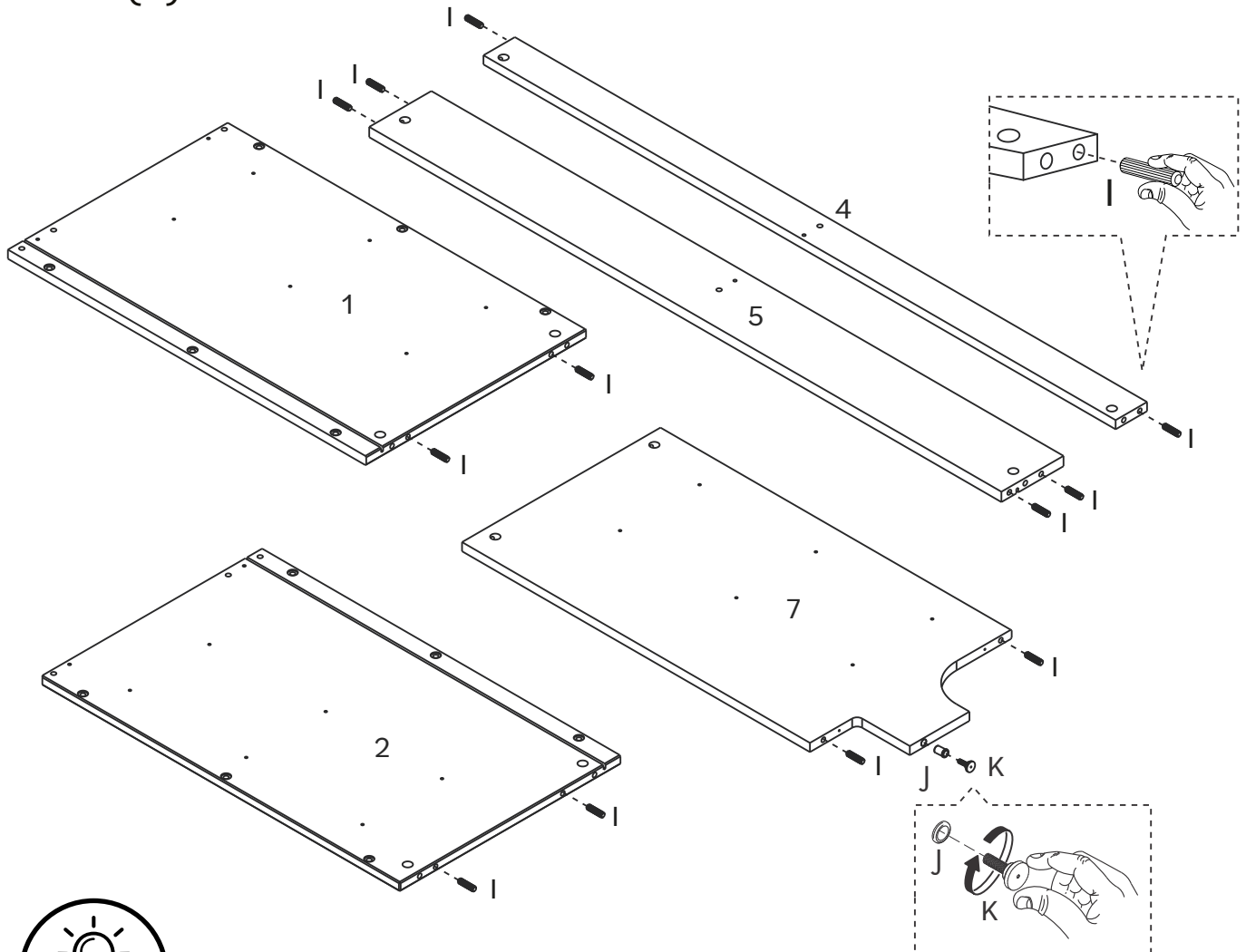

Tip

Wood Dowels

Dowels are essential in furniture assembly to create strong, precise connections.

They ensure structural integrity, prevent shifting, and simplify alignment, resulting in sturdier, longer-lasting furniture.

Follow these steps:

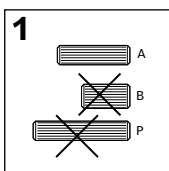

1: Select the appropriate size dowel listed in the step.

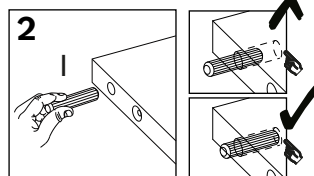

2: Insert into drilled hole and press firmly to ensure placement is set.

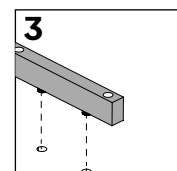

3: Align the dowel with corresponding piece and press together until secure.

Step 10

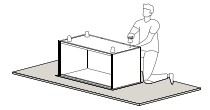

Attach Cam Bolts (L) to Left Panel (1), Right Panel (2) and Top Panel (3) using a Phillips screwdriver.

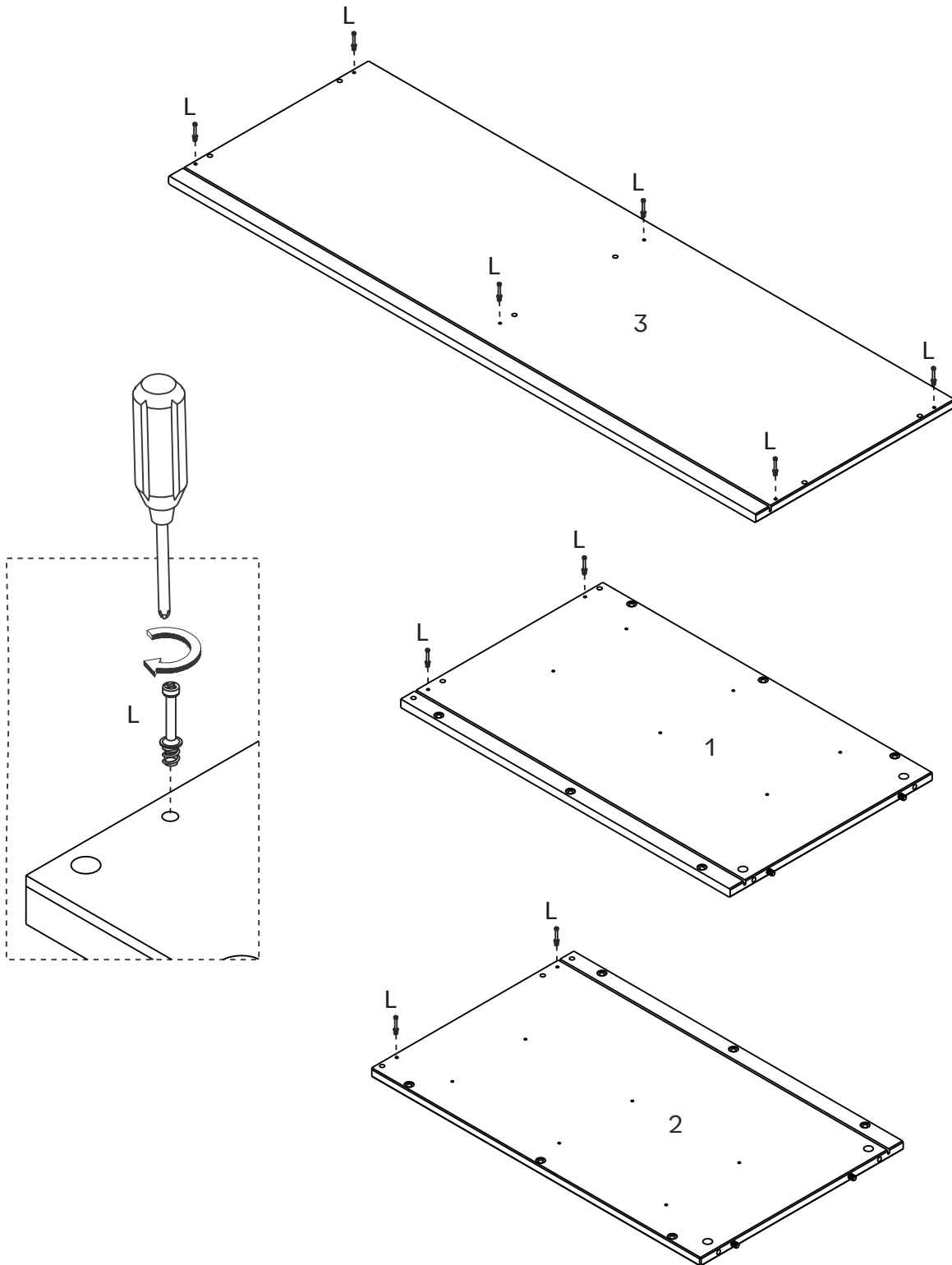

Step 11

Take Outer Slider (G1) and insert Interlock Lock (E) according to the diagram below.

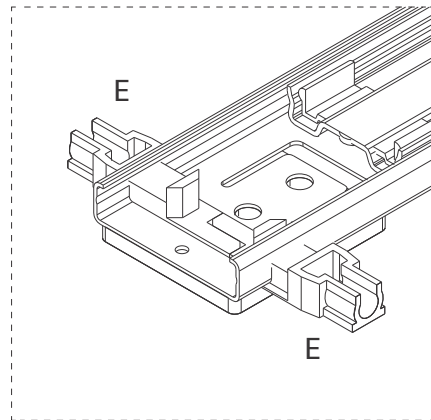
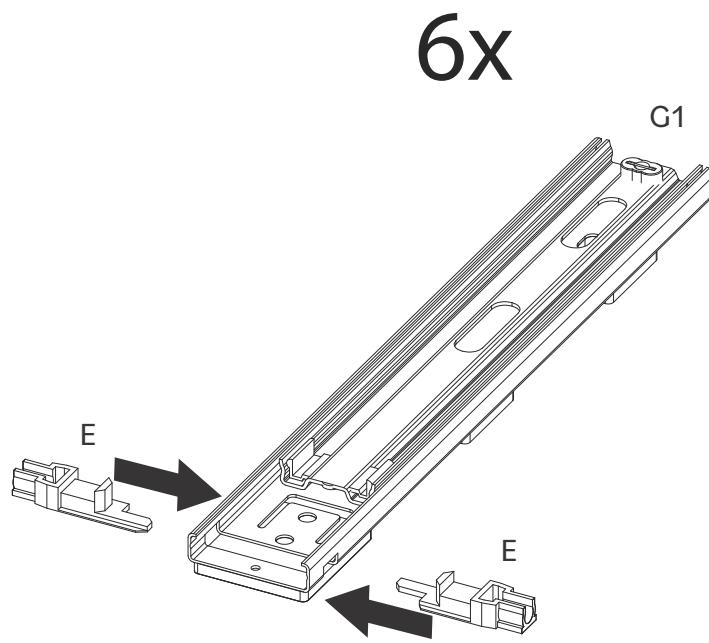

Step 12



Secure Outer Slider (G1) to Right Panel (2) and Left Panel (1) using Screw (X) and a Phillips screwdriver.

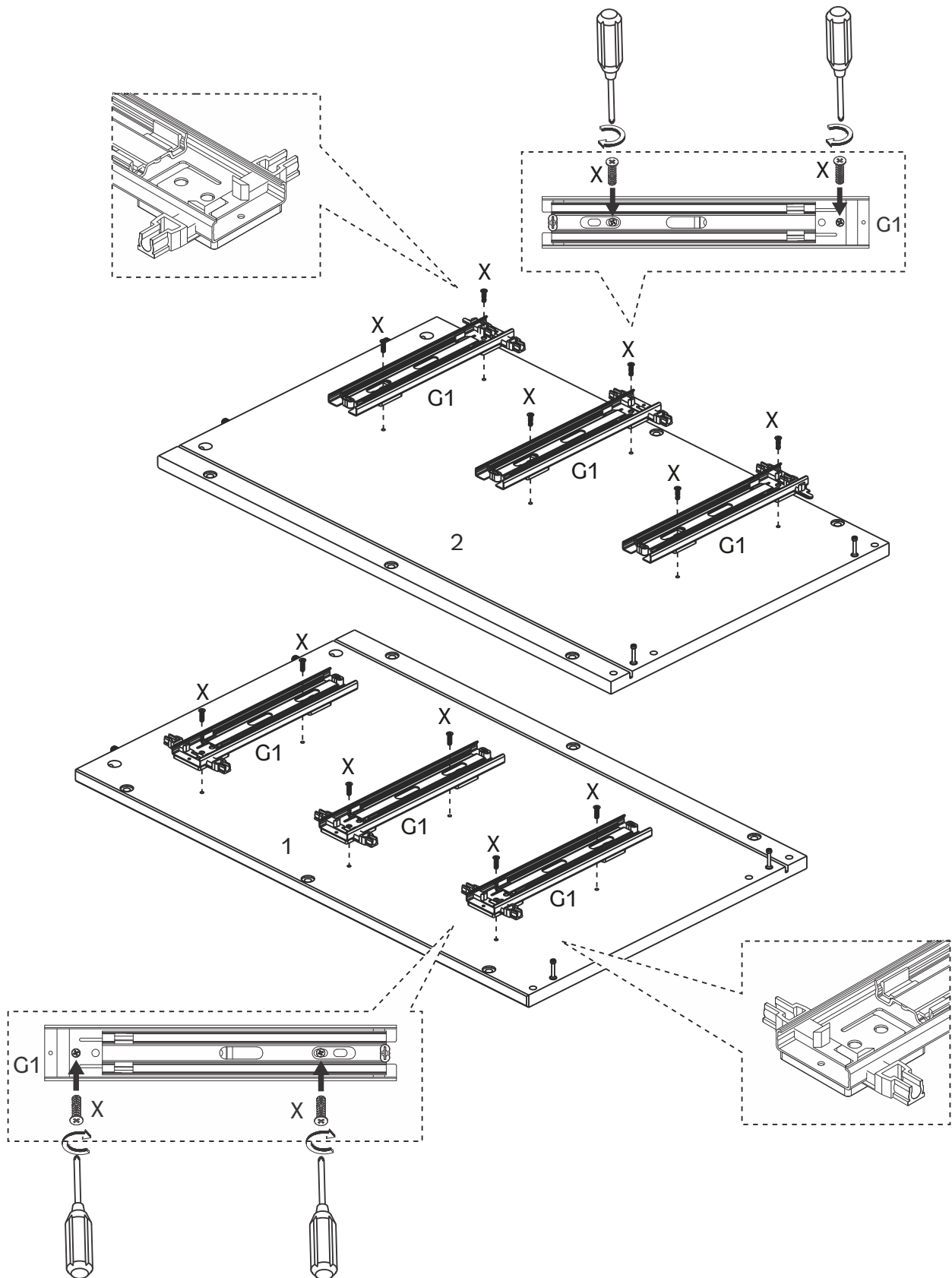

Step 13



Secure Outer Slider (G1) to both sides of Center Panel (7) using Screw (X) and a Phillips Screwdriver.

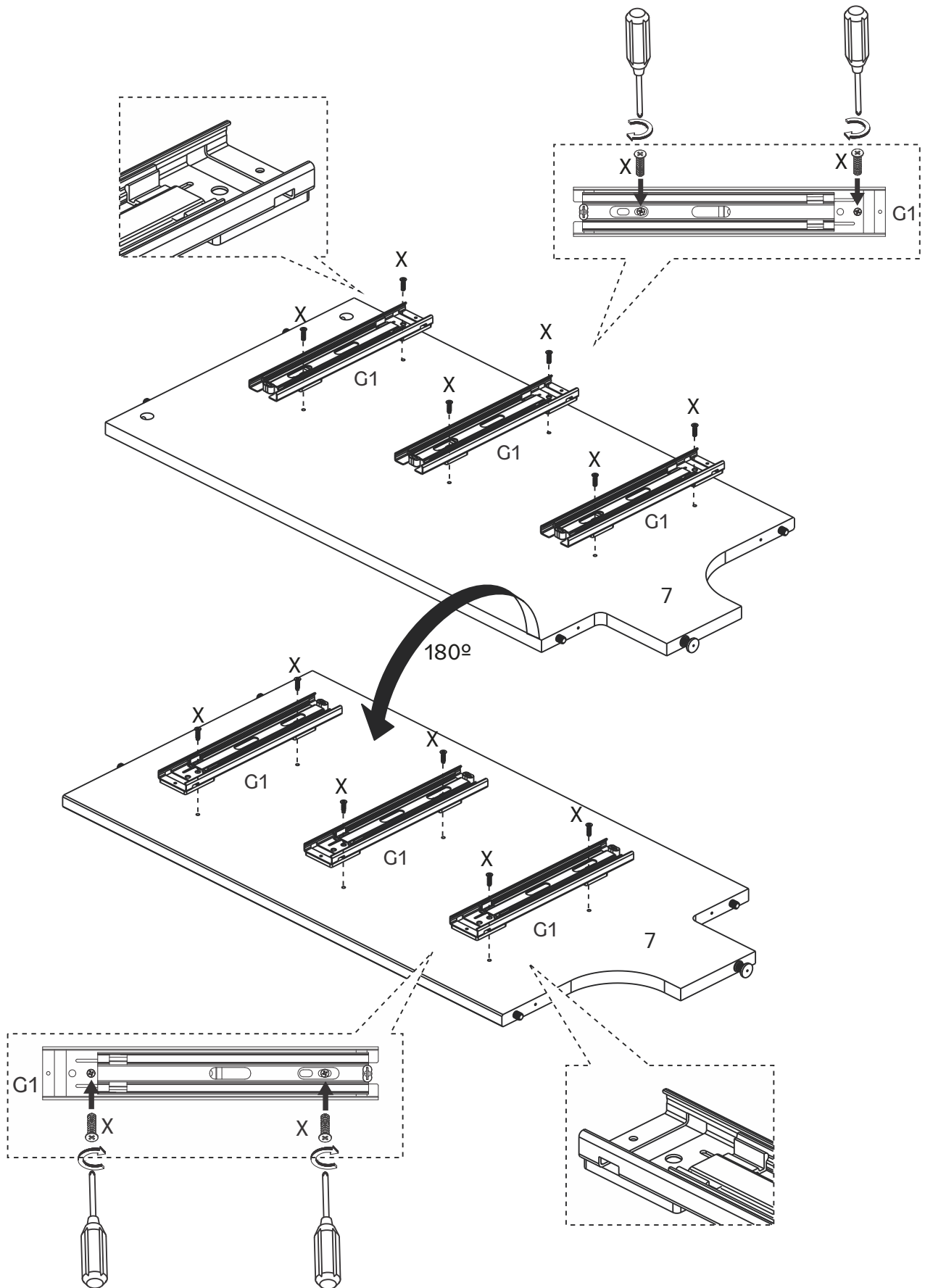

Step 14



Attach Top Panel (3) to Left Panel (1) using Cam Locks (M) and a Phillips screwdriver.

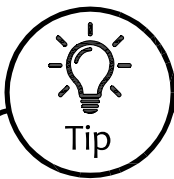
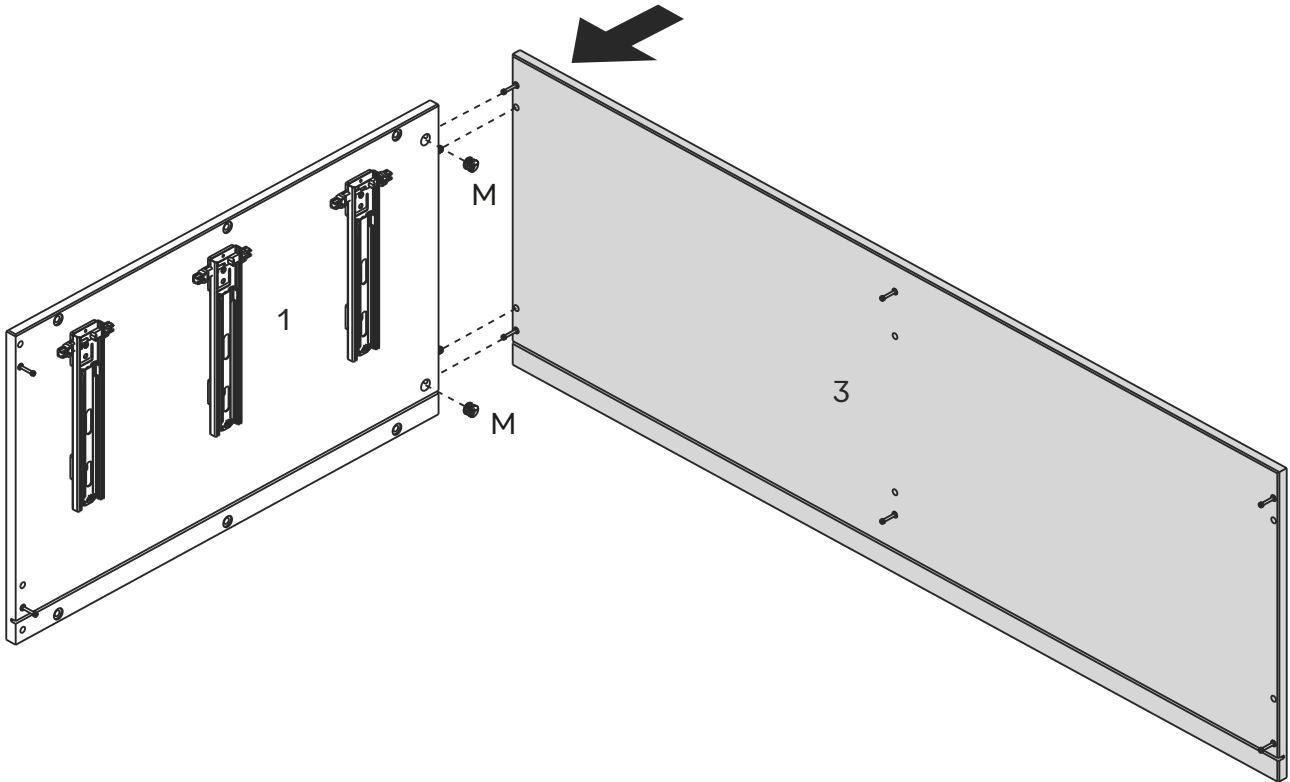

Tip

Cam Locks

Cam Locks help to securely join two pieces together. Follow these easy steps.

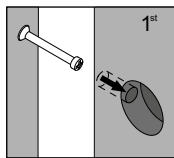

1: Insert Cam Bolt into bolt holes on the flat side. Don't over tighten!

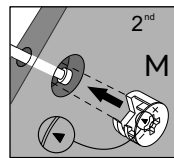

2: Connect the two pieces. The cam bolt goes into the drilled hole with a circular hole on the other side - you should be able to see the cam bolt through it. After fitting the parts together, insert the cam lock into the circular hole.

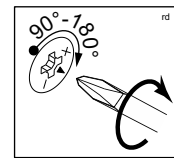

3: On the back of the Cam Lock will be a "C" shape. Insert the Cam Lock so the opening of the "C" fits over the Cam Bolt. Tighten with the screwdriver.

Step 15



Secure Center Panel (7) to Top Panel (3) using Cam Locks (M) and a Phillips screwdriver.

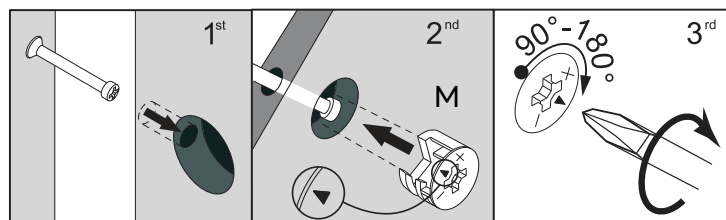
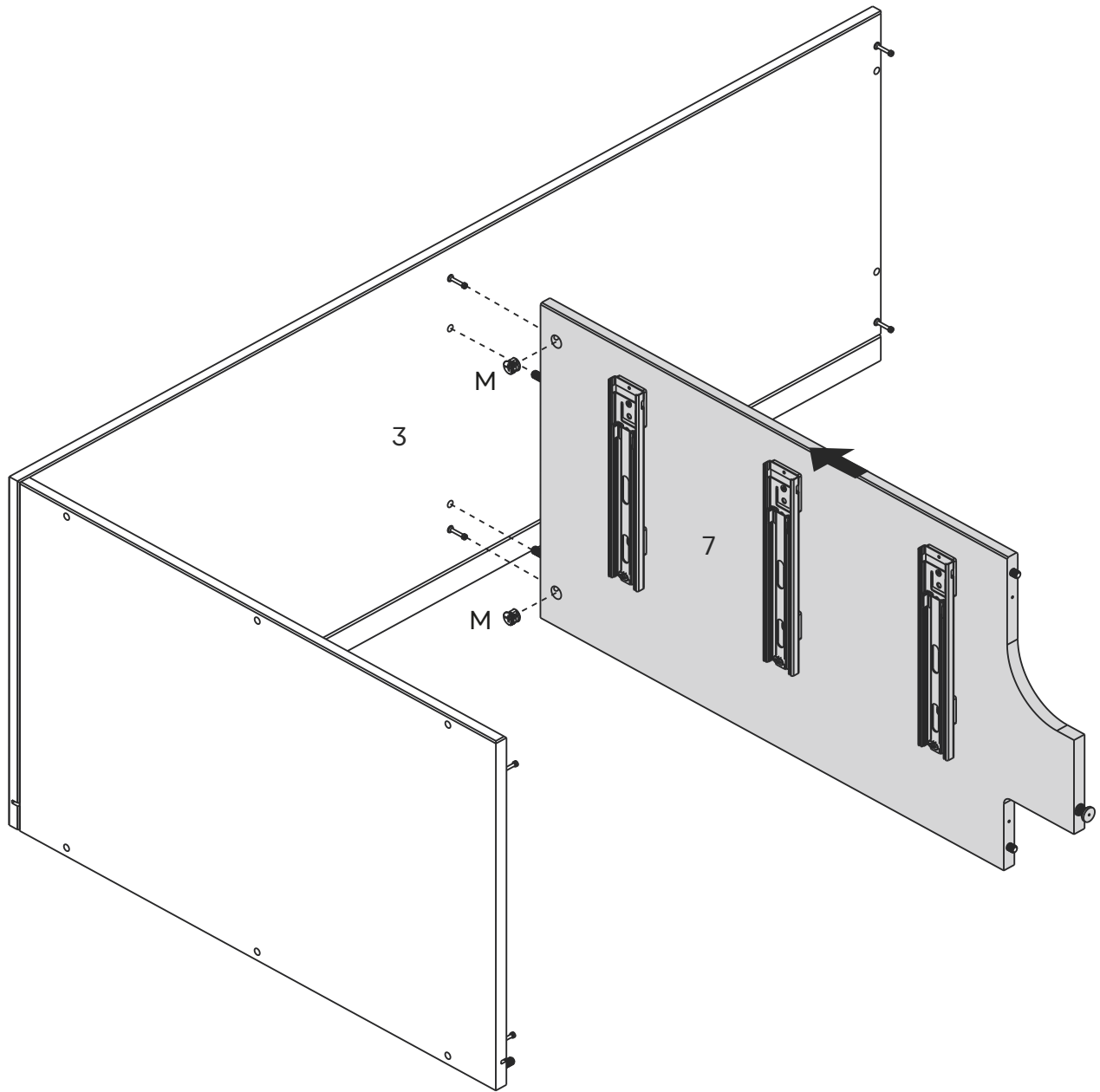

Step 16

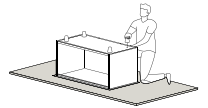

Join Back Rail (5) to Left Panel (1) and Center Panel (7) using Cam Lock (M) with Screw (P) and a Phillips screwdriver.

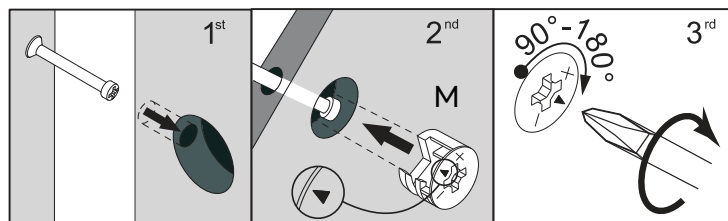
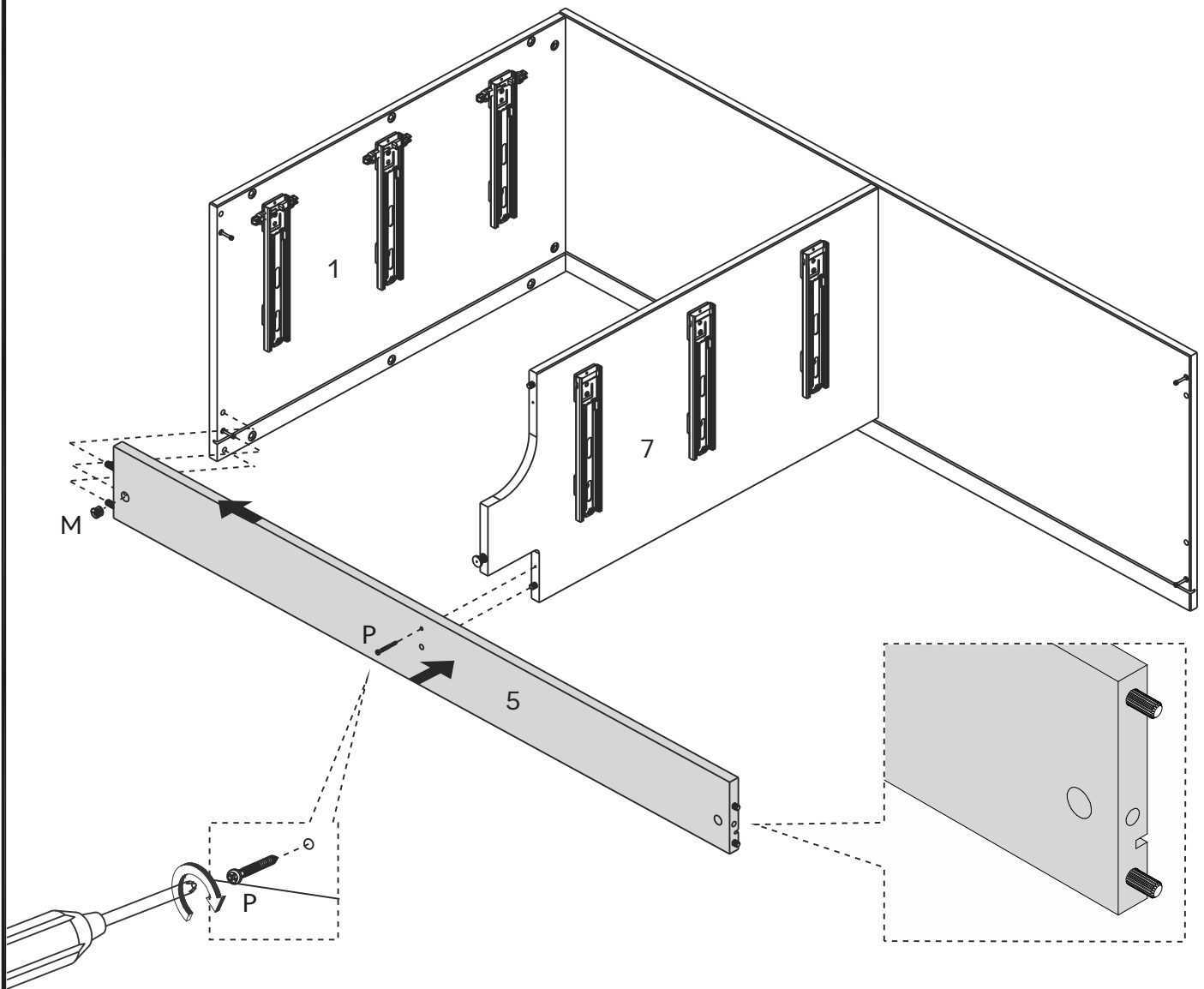

Step 17

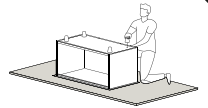

Join Front Rail (4) to Left Panel (1) using Cam Locks (M) and to Center Panel (7) with Screw (P) and a Phillips screwdriver.

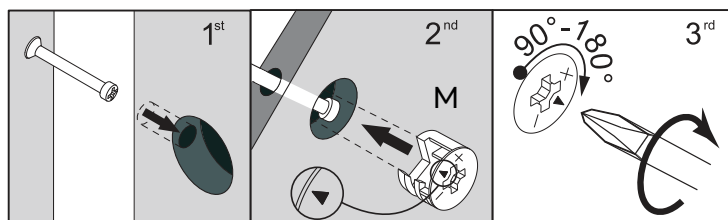
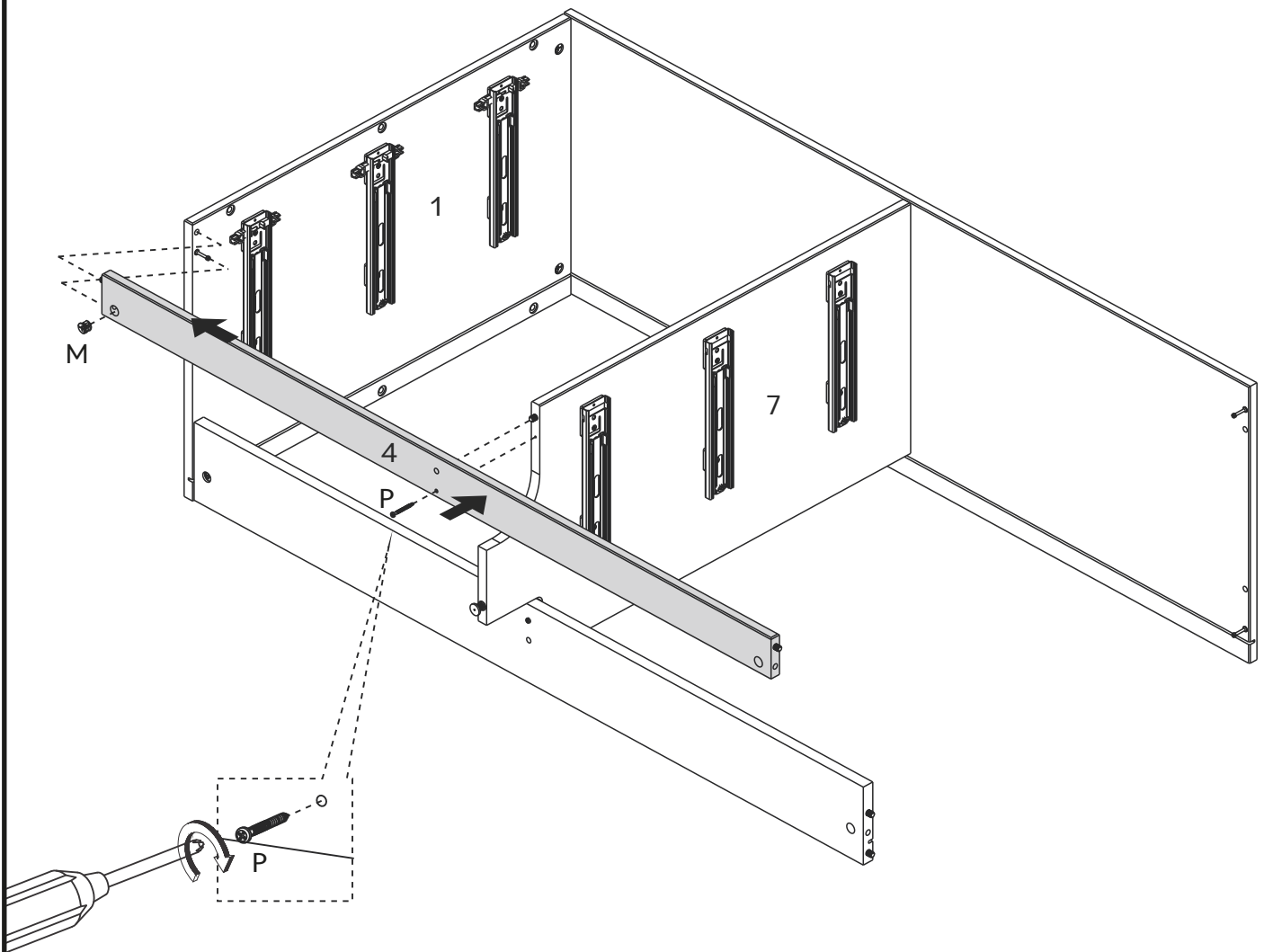

Step 18



Slide Back Panel (6) on the grooves between Top Panel (3) and Back Rail (5), fitting in Left Panel (1).

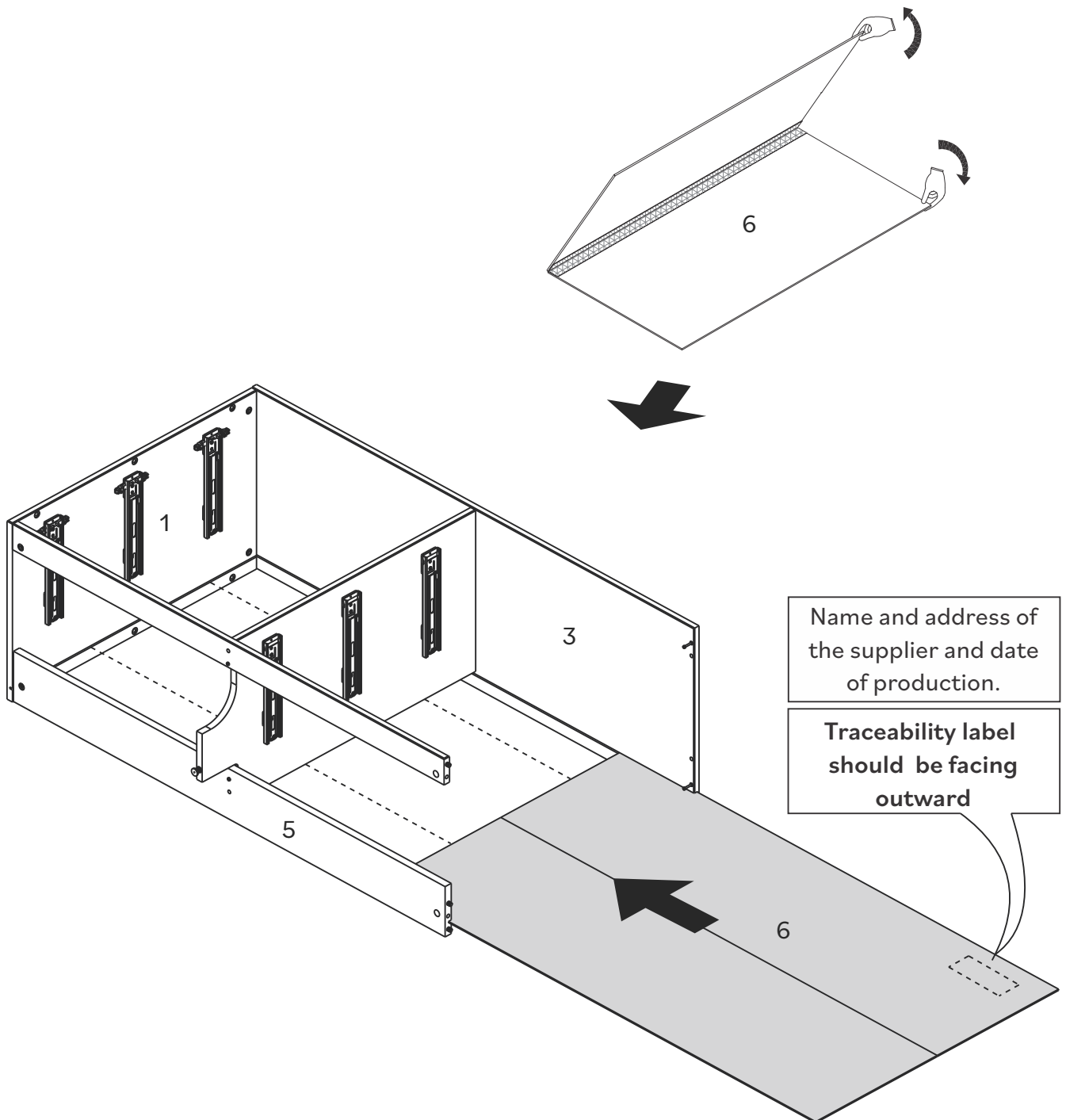

Name and address of the supplier and date of production.

Traceability label should be facing outward

Step 19

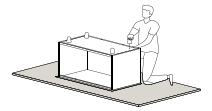

Now, join Right Panel (2) using Cam Locks (M) and a Phillips screwdriver.

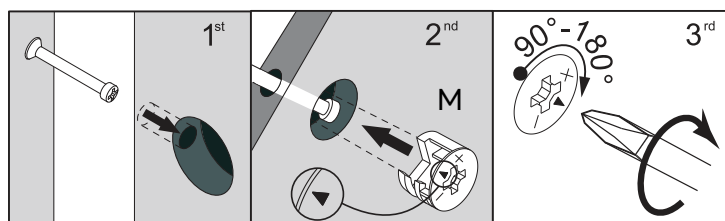
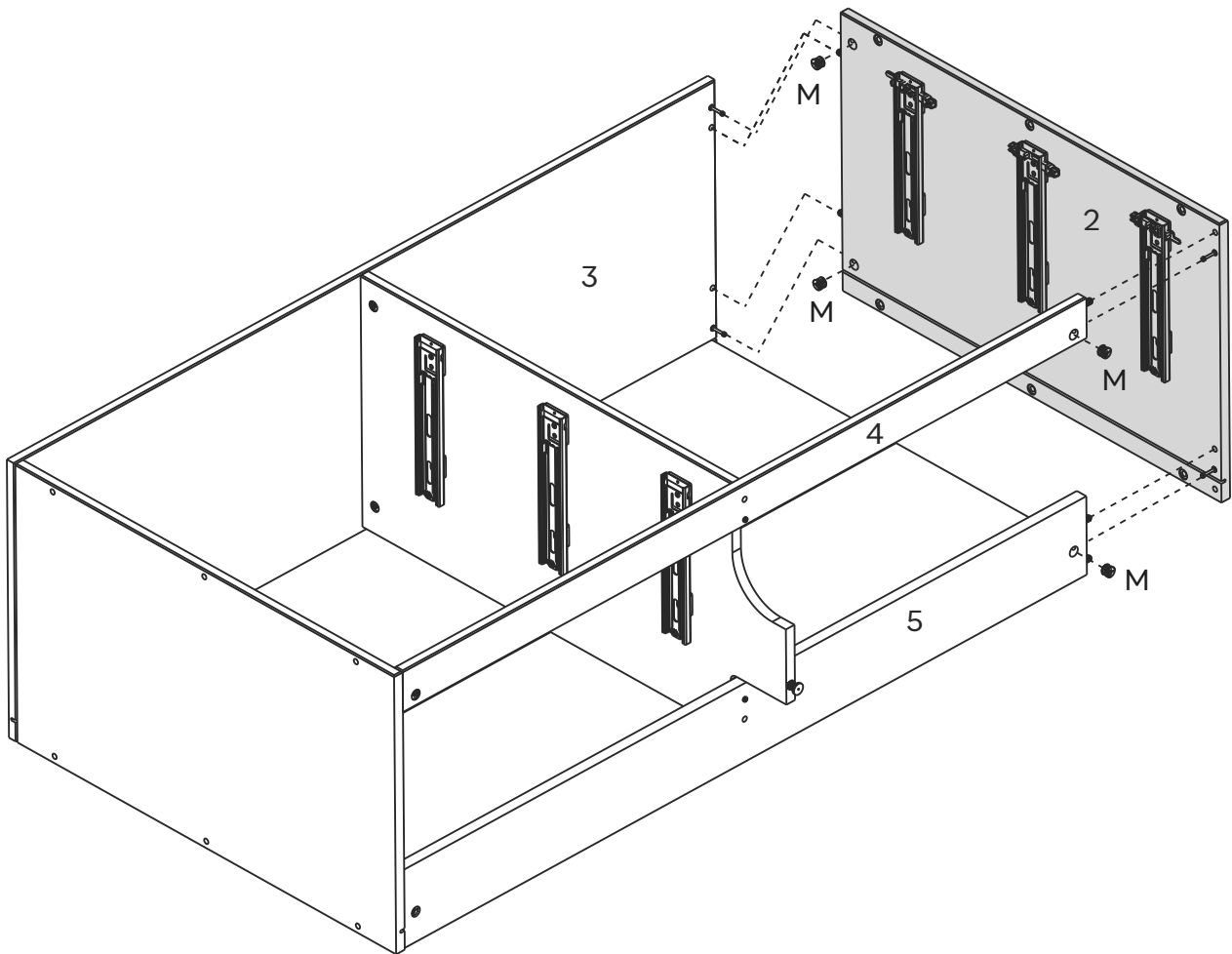

Step 20

Secure Left Foot (8) to Left Panel (1) using Bolt (O) and Hex Key (Q). Do the same to Right Foot (9) on Right Panel (2).

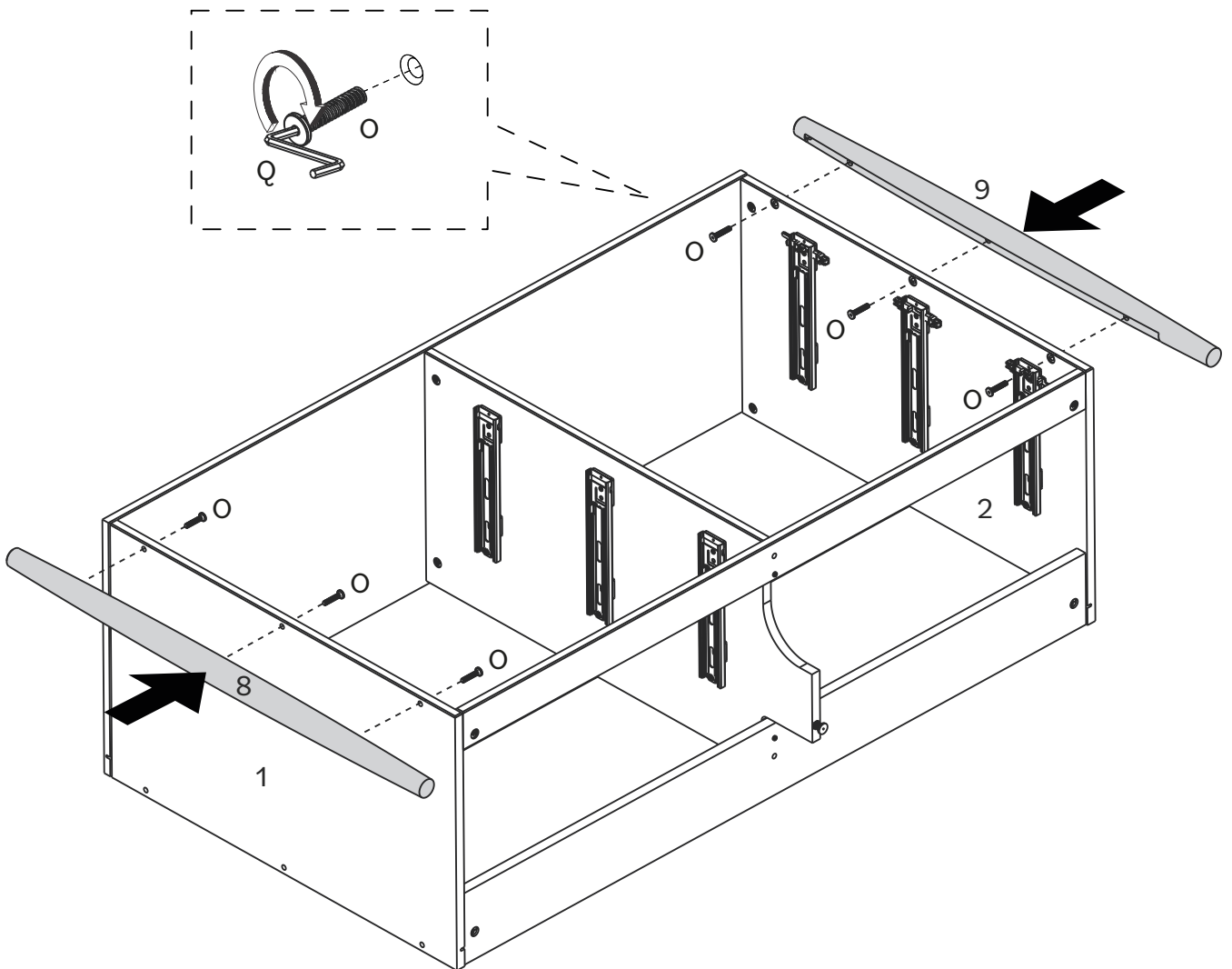

Step 21

Lift your new dresser and attach Left Foot (8) on the other end of Right Panel (2) using Bolt (O) and Hex Key (Q). Do the same to Right Foot (9) on Left Panel (1).

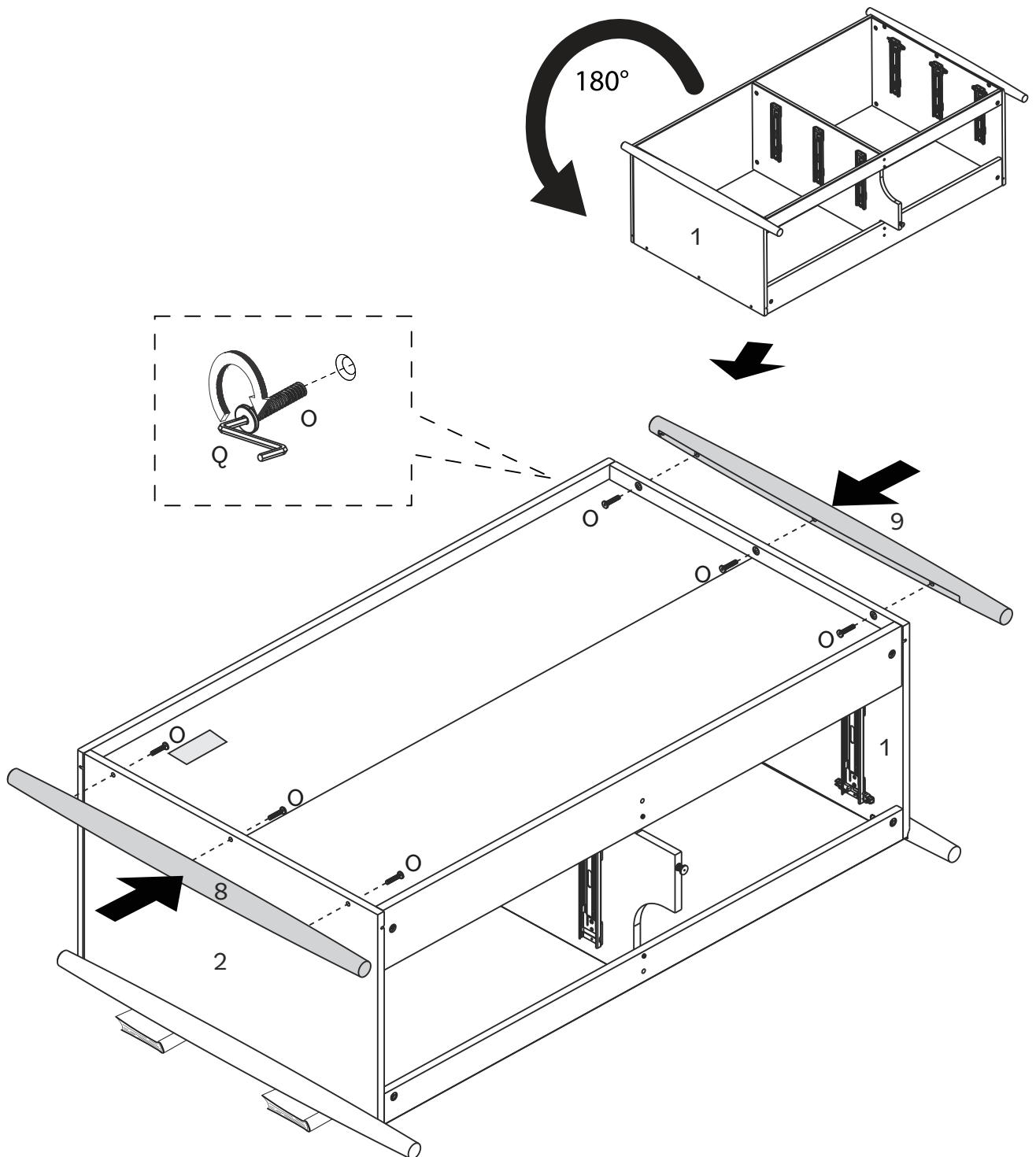

Step 22

Secure Back Panel (6) fitting Wedge (R) and screw (Z) between the panel and the grooves. Use and a Phillips screwdriver.

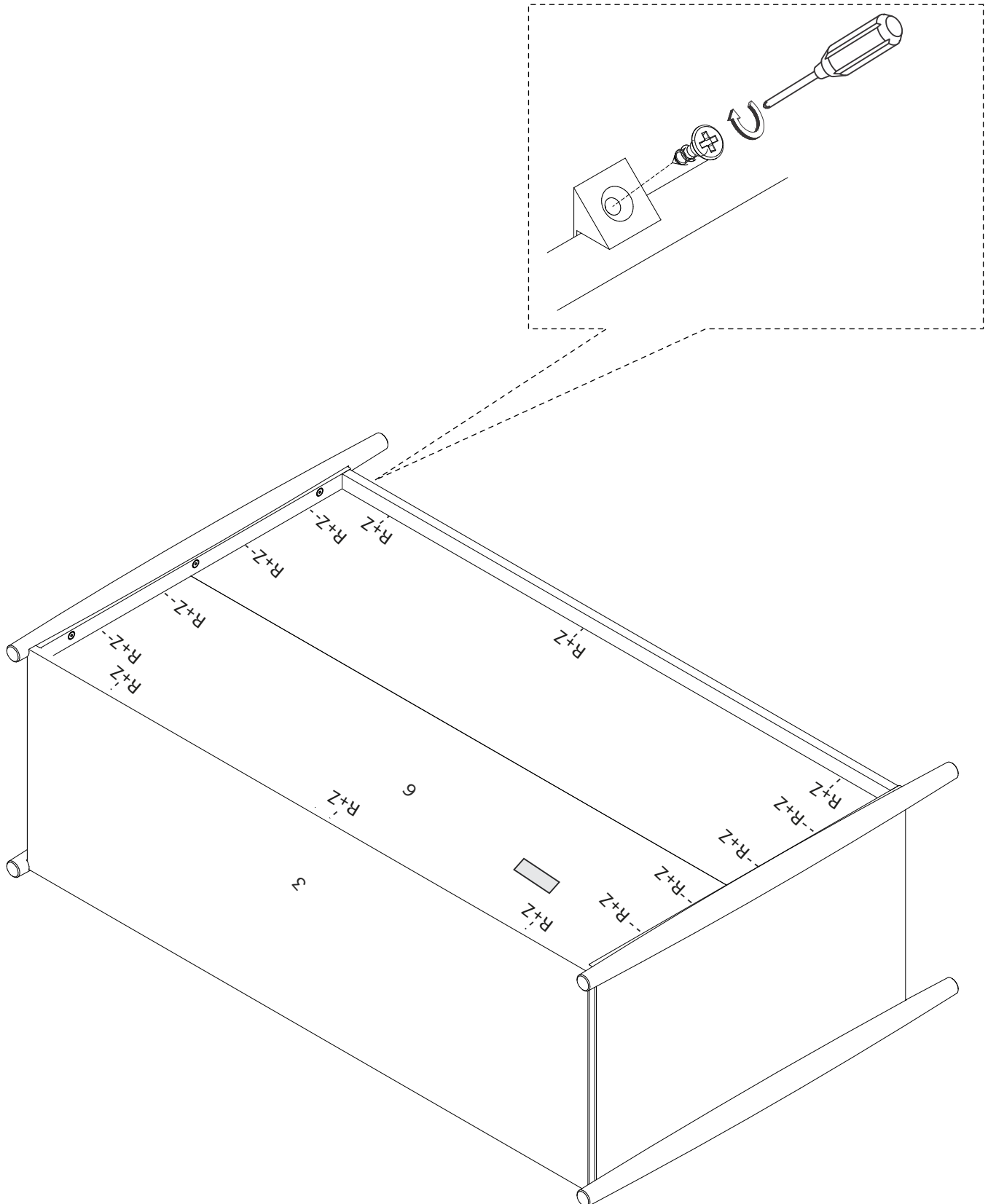

Step 23

Attach Interlock Bar (E) in the Locks (N).

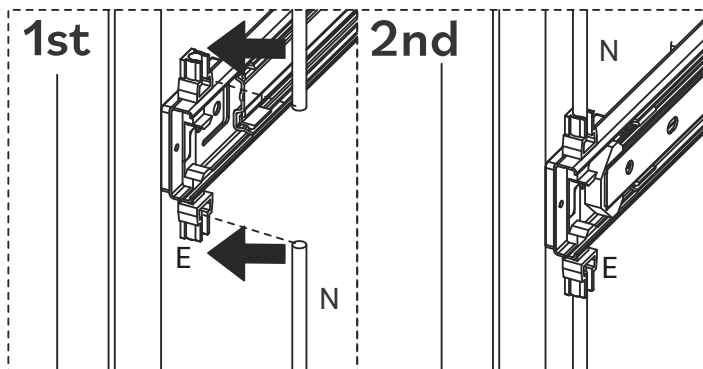
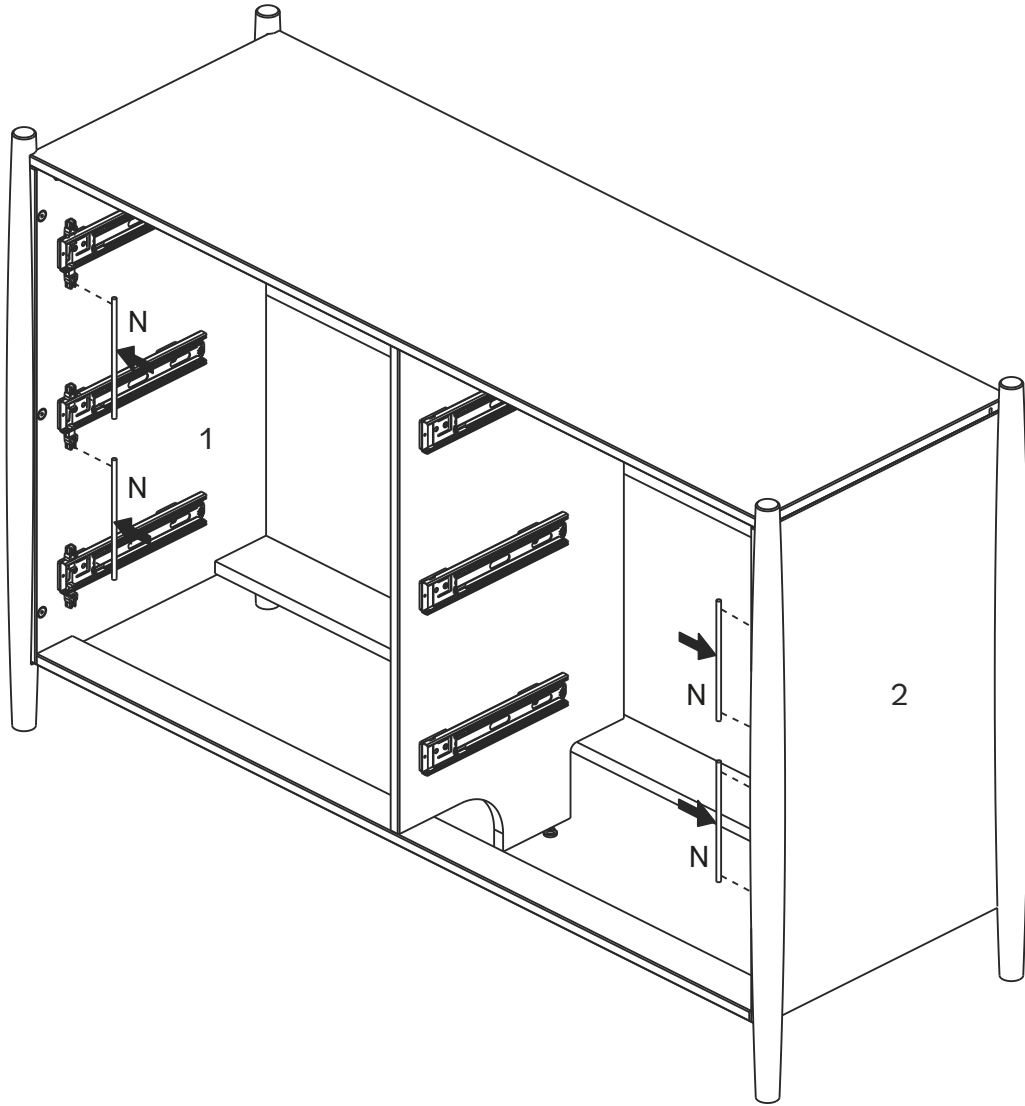

Step 24

Place the Drawers one at a time using the slider, pay attention to position them correctly aligning Outer and Inner Slider.

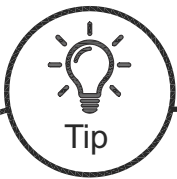
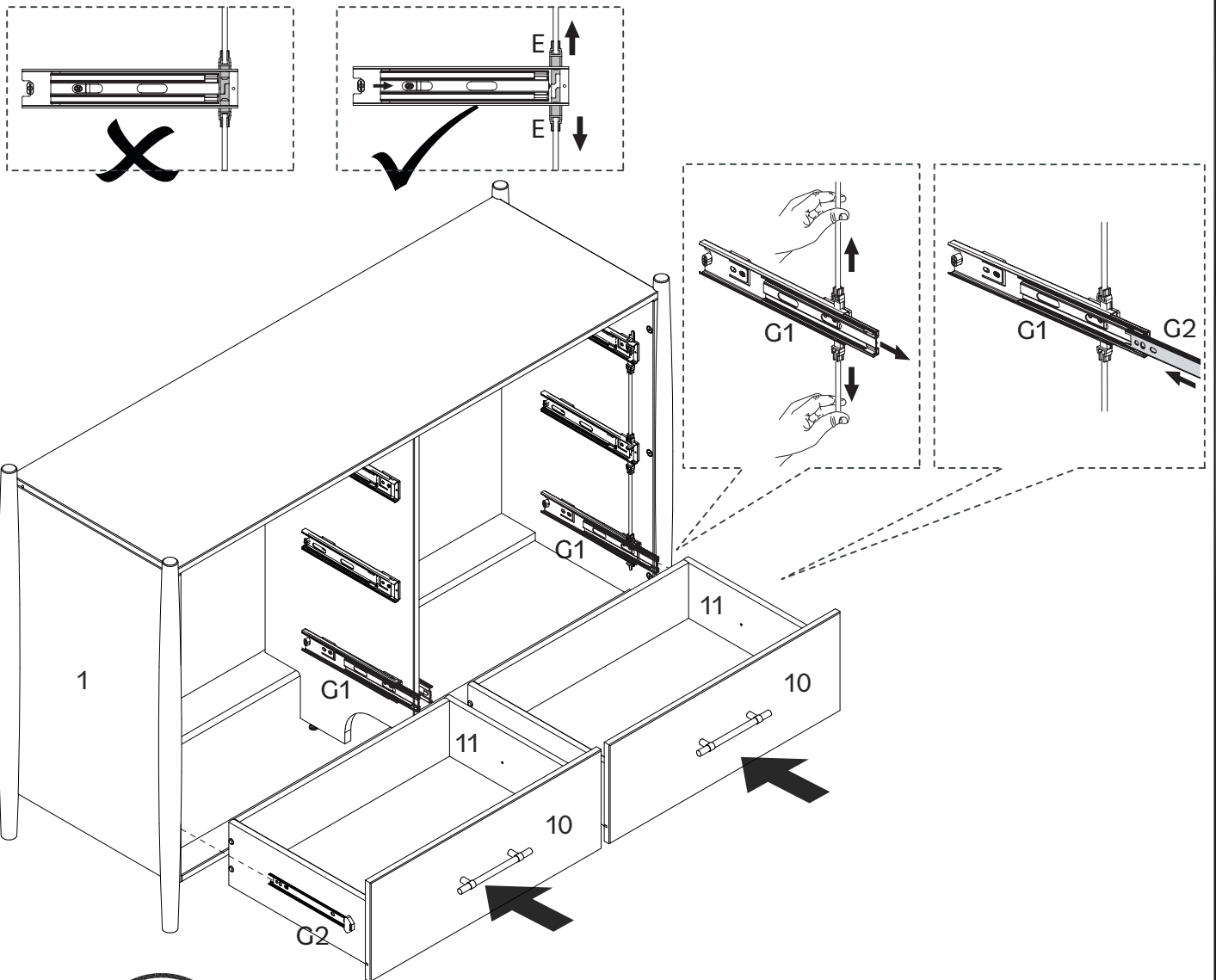

Tip

Insert your Cabinet Drawer Correctly

Line up Outer and Inner Slider and push the drawer slightly inside the unit, once you feel the connection push the drawer entirely into place. It may not be a smooth gliding at first, but it improves once fully connected.

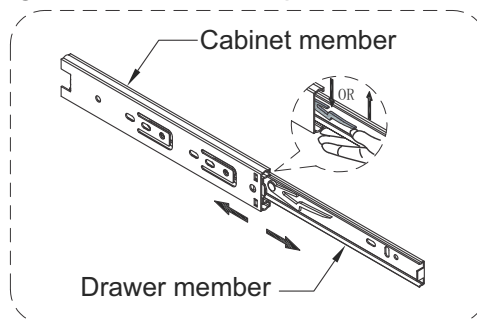

Step 25

Place the Drawers one at a time using the slider, pay attention to position them correctly aligning Outer and Inner Slider.

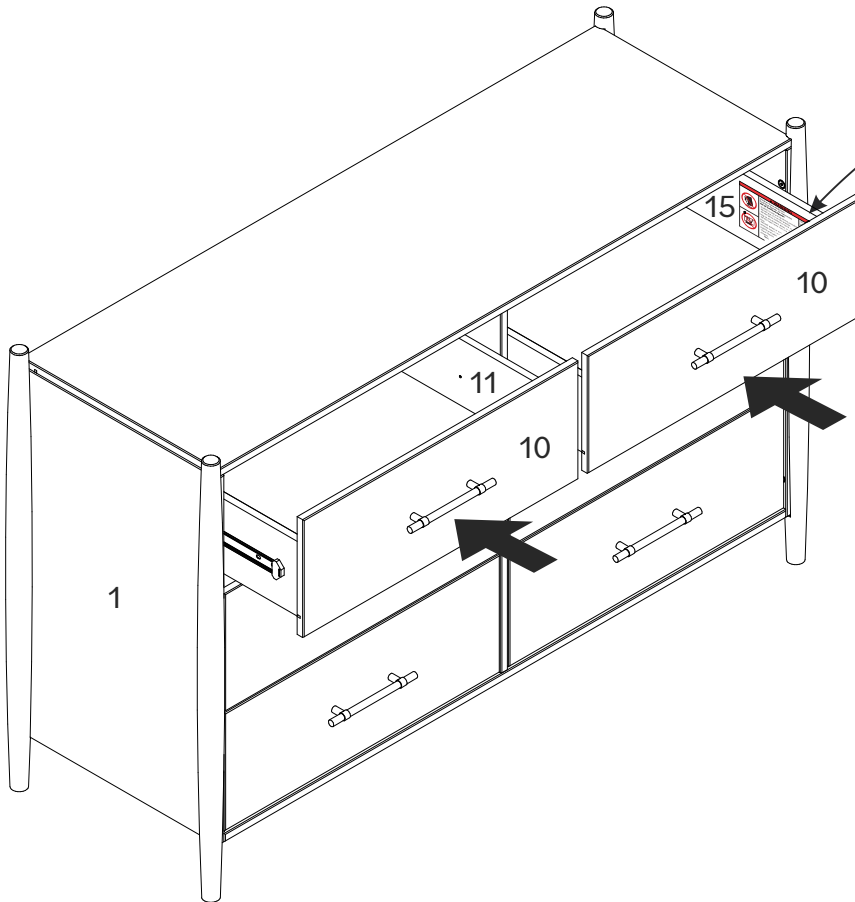

⚠ WARNING	
 <p>Children have died from furniture tipover. To reduce the risk of furniture tipover:</p> <ul style="list-style-type: none"> -ALWAYS install anti tip device provided. -NEVER put a TV on this product. -NEVER allow children to stand, climb or hang on any drawers, doors, or shelves. -NEVER open more than one drawer at a time. -DO NOT defeat or remove the drawer interlock system. It is an important stability and safety system. -Place heaviest items in the lowest drawers. <p><i>This is a permanent label. Do not remove!</i></p>	<p>DO NOT remove the interlock system except for maintenance as shown. NEVER use the unit without the interlock installed following the instructions.</p> <p>System Specific Instructions for interlock installation.</p> <p>Insert Interlock Lock on the sliders. After securing the sliders to the cabinet, attach the Interlock Bars to the Locks. Once this is done you can place the drawer one at a time. To remove the drawer push the locks in the sliders</p>

The Drawer Side with **Warning Label** should be positioned as the highest drawer.

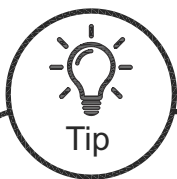
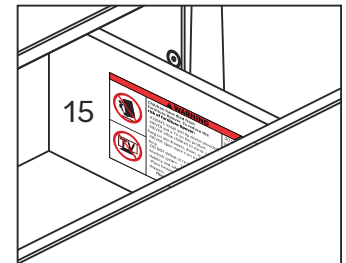

Removing the Drawer

There is a white lever in each slider, to remove the drawers pull the drawer out until you see the lever. Push one lever up and the other down, while pushing, bring the drawer out

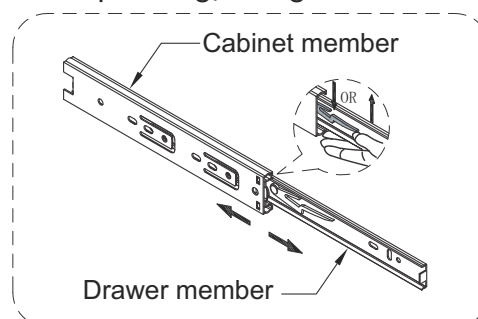

Step 26

To finish this up, attach the anti-tipping kit. Secure Wall Anchor (S) to Top Panel (3) using Washer (V), Screw (T) and a Phillips screwdriver following the details in the diagram below.

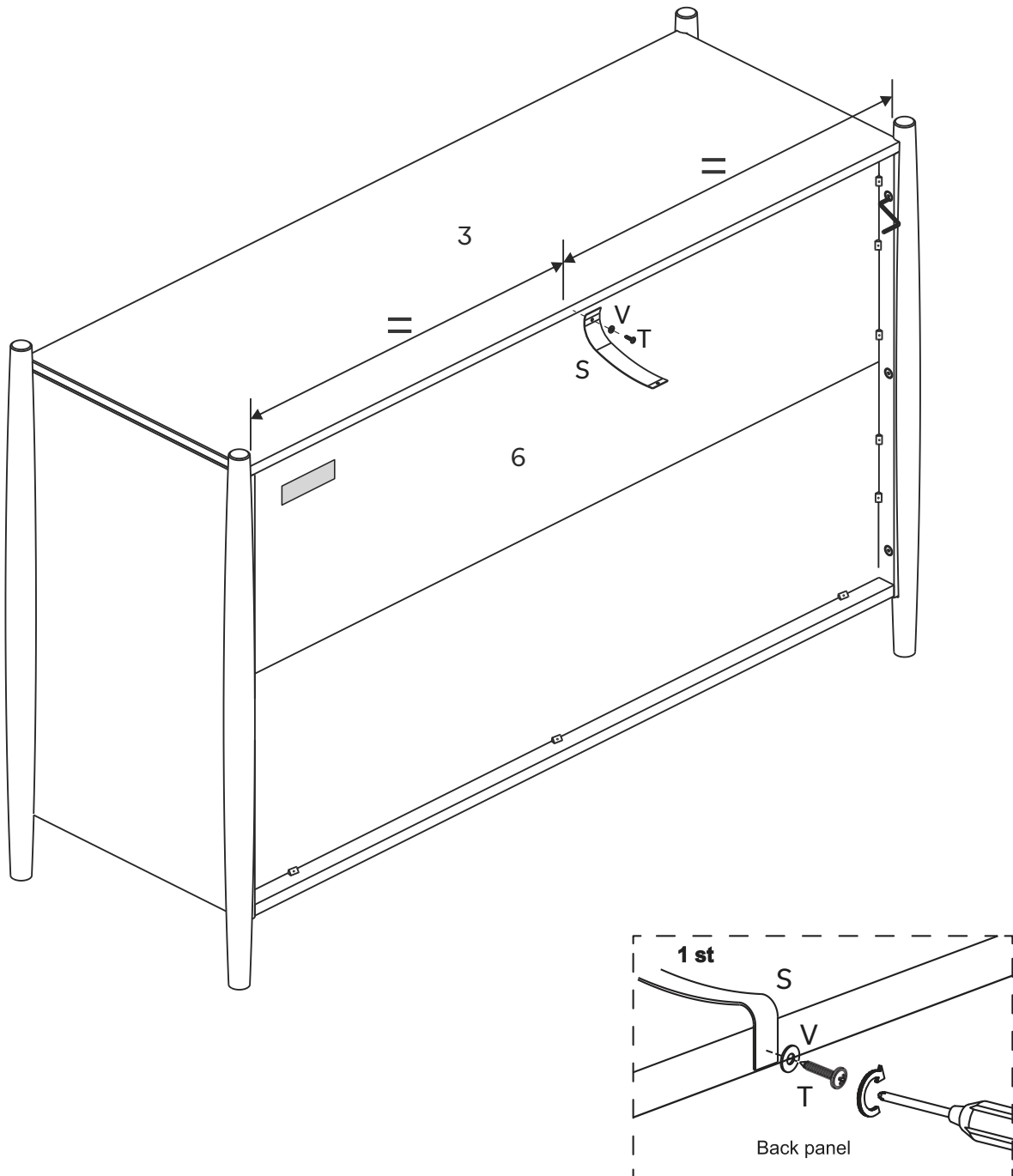

Step 27

Last step! Insert Plastic Bush (U) into the wall. Then, secure Wall Anchor (S) to the wall using Washer (V) and Screw (P).

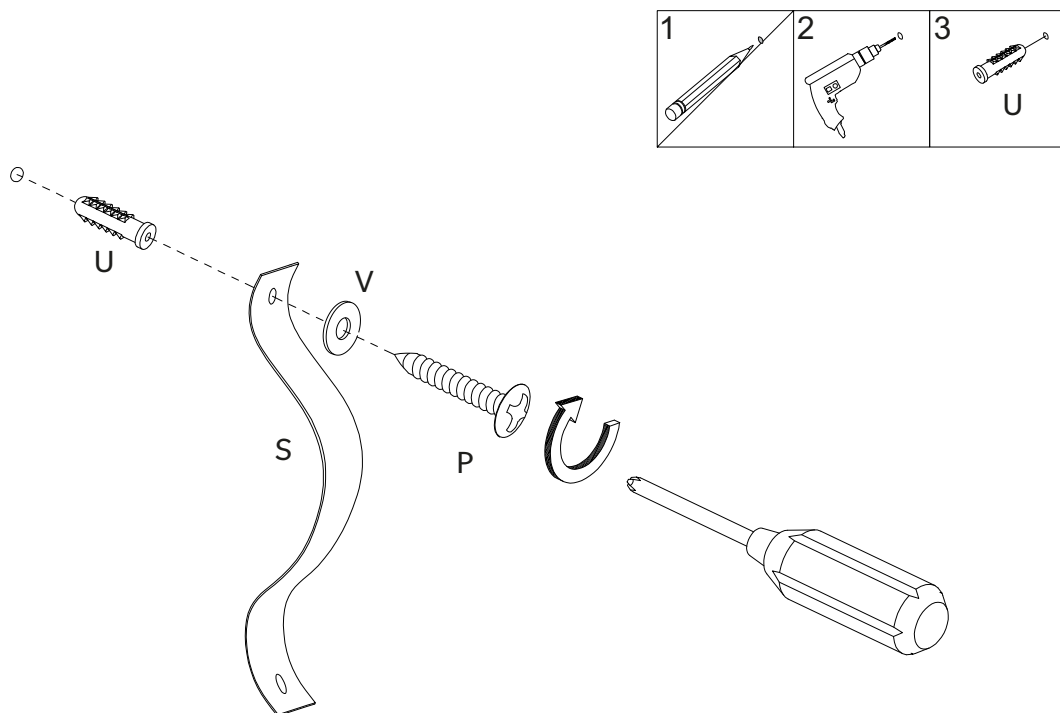

Warning

Serious or fatal injuries can occur from furniture tipping over. To prevent the furniture from tipping over we recommend that it is permanently fixed to the wall. Wall anchor and hardware are included with this product. Please make sure hardware is suitable for your walls before installing, as different wall materials may require different types of anchors.

Name and address information for the manufacturer responsible for the anti-tip hardware and date of production can be found on the label on the back of the furniture.

To Disassemble



If it is necessary to disassemble, remove the Dovetail locker (B) with a Slotted head screwdriver.

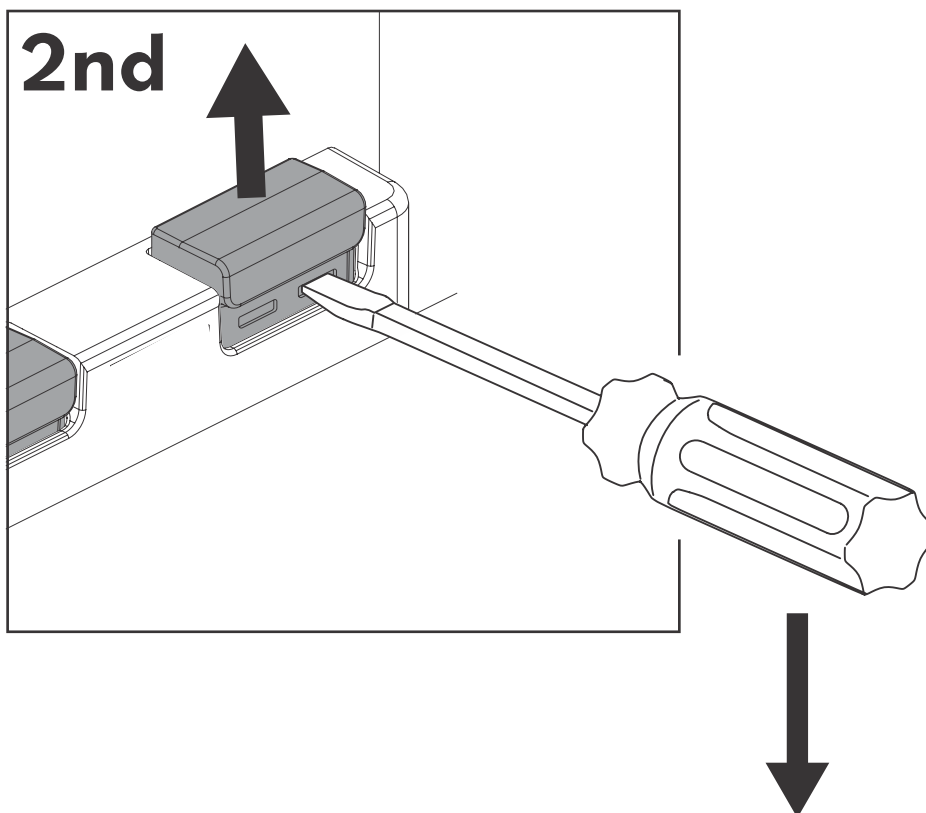
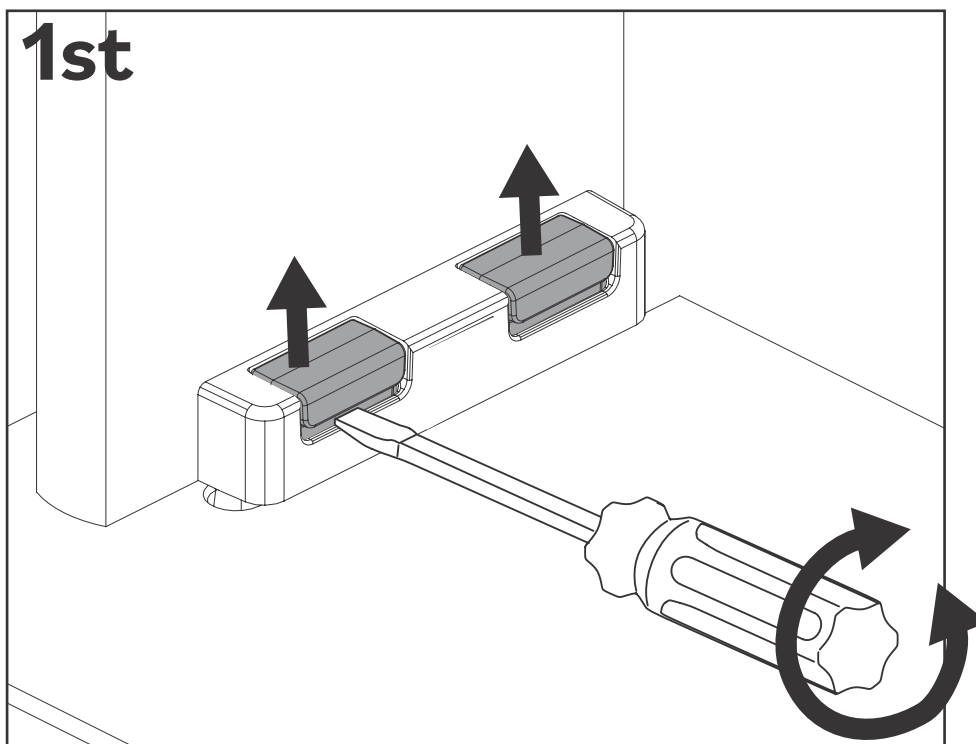

You did it! Enjoy your new Dresser!

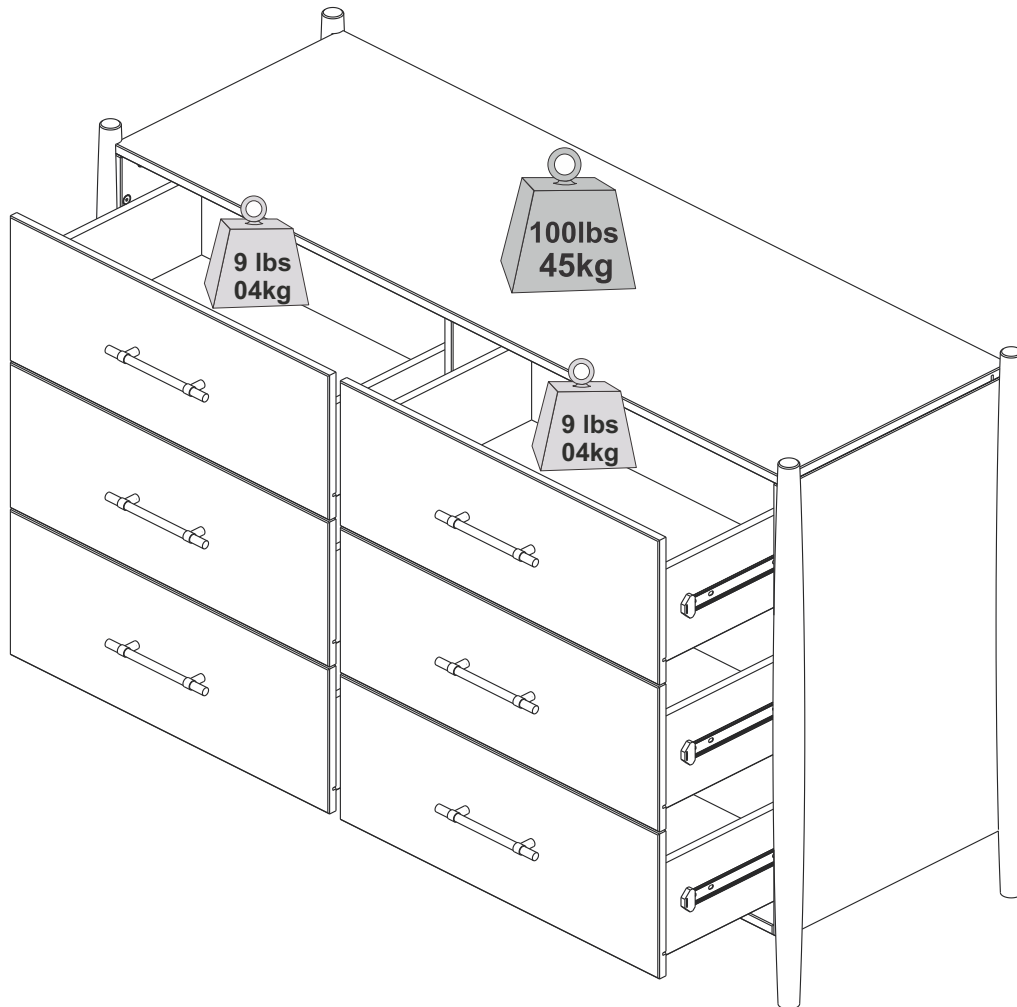

Congratulations on your new piece of furniture!

We would love to hear about it and see it.
Please leave us a review or post a picture with

Commode à 6 tiroirs
Cómoda 6 con cajones

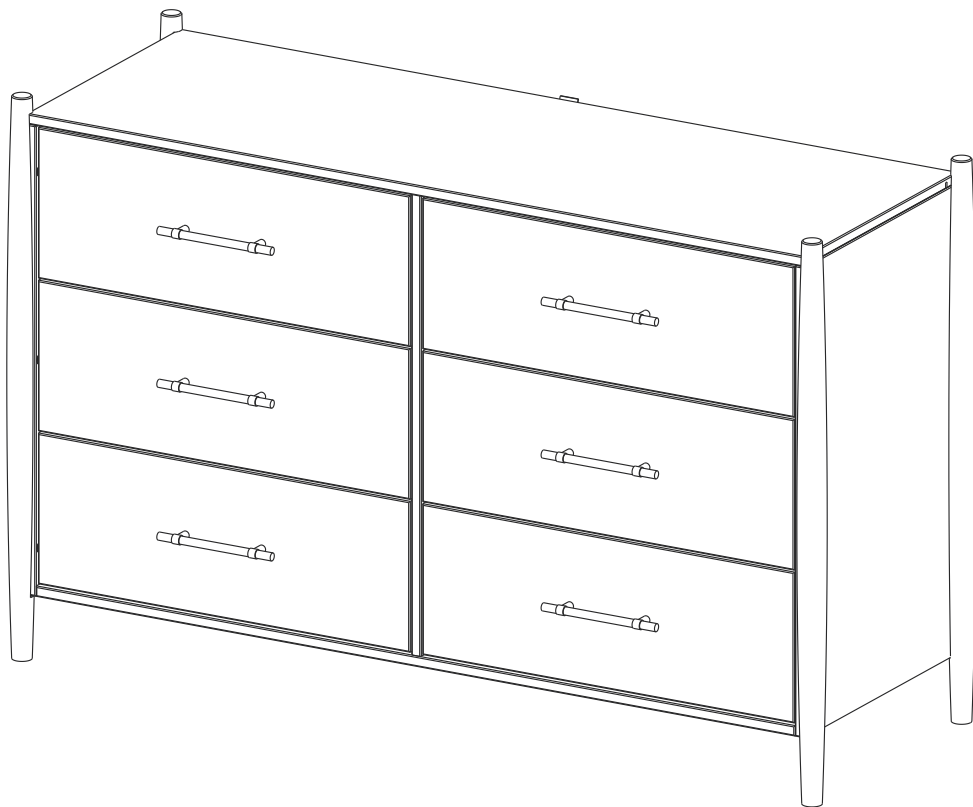

Pour usage résidentiel seulement

Sólo para uso residencial

Il est temps de commencer / Hora de empezar

Prépare un lieu de travail propre et souple pour éviter tout dommage lors de l'assemblage. Tu peux utiliser la boîte et les protections internes comme base. Vérifie également que tu disposes de toutes les pièces et parties avant de te lancer dans l'assemblage.

Prepare un lugar de trabajo limpio y blando para evitar daños durante el montaje. Puede utilizar la caja y las protecciones internas como base. Comprueba también que tiene todas las piezas y partes antes de sumergirse en el montaje.

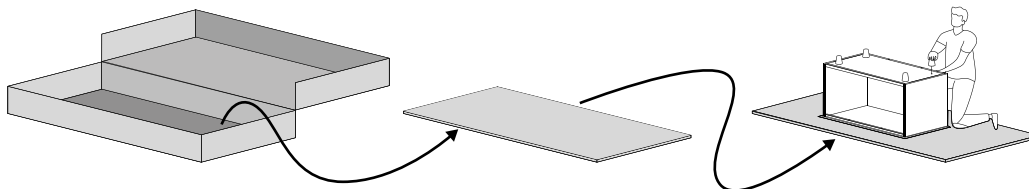

**Temps de montage
estimé**

**Tiempo estimado de
montaje**

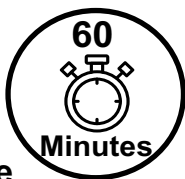

2 Personnes
2 Personas

**Personnes recommandées
pour le montage**

Fais-en un effort d'équipe !
Appelle un ami pour un assemblage
plus rapide et plus facile.

**Personas recomendadas
para el montaje**

¡Hágalo en equipo!
Llame a un amigo para que el
montaje sea más rápido y sencillo.

Outils nécessaires

Munis-toi d'un tournevis, tournevis cruciforme et marteau pour réaliser cet assemblage.

Herramientas requeridas

Tome un destornillador, destornillador Phillips y martillo para conquistar este montaje.

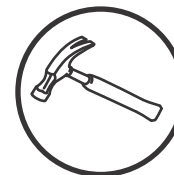

Utilise les outils électriques avec précaution

Ce meuble est réalisé en Bois Massif et Bois Composite, des matériaux souples. Si tu choisis d'utiliser des outils électriques, règle-les sur le mode le plus lent. Fais attention à toi ! Les outils électriques peuvent provoquer des fissures ou endommager les meubles, mais aussi les autres composants s'ils sont mal utilisés.

Utilice las herramientas eléctricas con cuidado.

Este mueble está fabricado con madera maciza y madera compuesta, materiales blandos. Si decide utilizar herramientas eléctricas, ajústelas al ajuste más lento. Tenga cuidado. Las herramientas eléctricas pueden causar grietas o daños en el mueble, pero también en los herrajes si se utilizan mal.

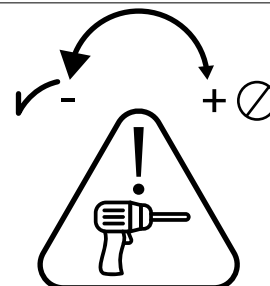



Liste de pièces / Lista de piezas

Nombre de pièces Número de pieza	Description Descripción	Quantité Cantidad
1	Panneau Droit Panel Derecho	1
2	Panneau Gauche Panel Izquierdo	1
3	Panneau Supérieur Panel Superior	1
4	Rail Avant Riel Delantero	1
5	Rail Arrière Riel Trasero	1
6	Panneau Arrière Panel Trasero	1
7	Panneau Central Panel Central	1
8	Pied Droit Pie Derecho	2
9	Pied Gauche Pie Izquierdo	2
10	Façade du Tiroir Droit Frente del Cajón Derecho	6
11	Côté Droit du Tiroir Lado Derecho del Cajón	5
12	Côté Gauche du Tiroir Lado Izquierdo del Cajón	6
13	Arrière du Tiroir Posterior del Cajón	6
14	Fond du Tiroir Inferior del Cajón	6
15	Façade du Tiroir Droit Avertissement Frente del Cajón Derecho Advertencia	1







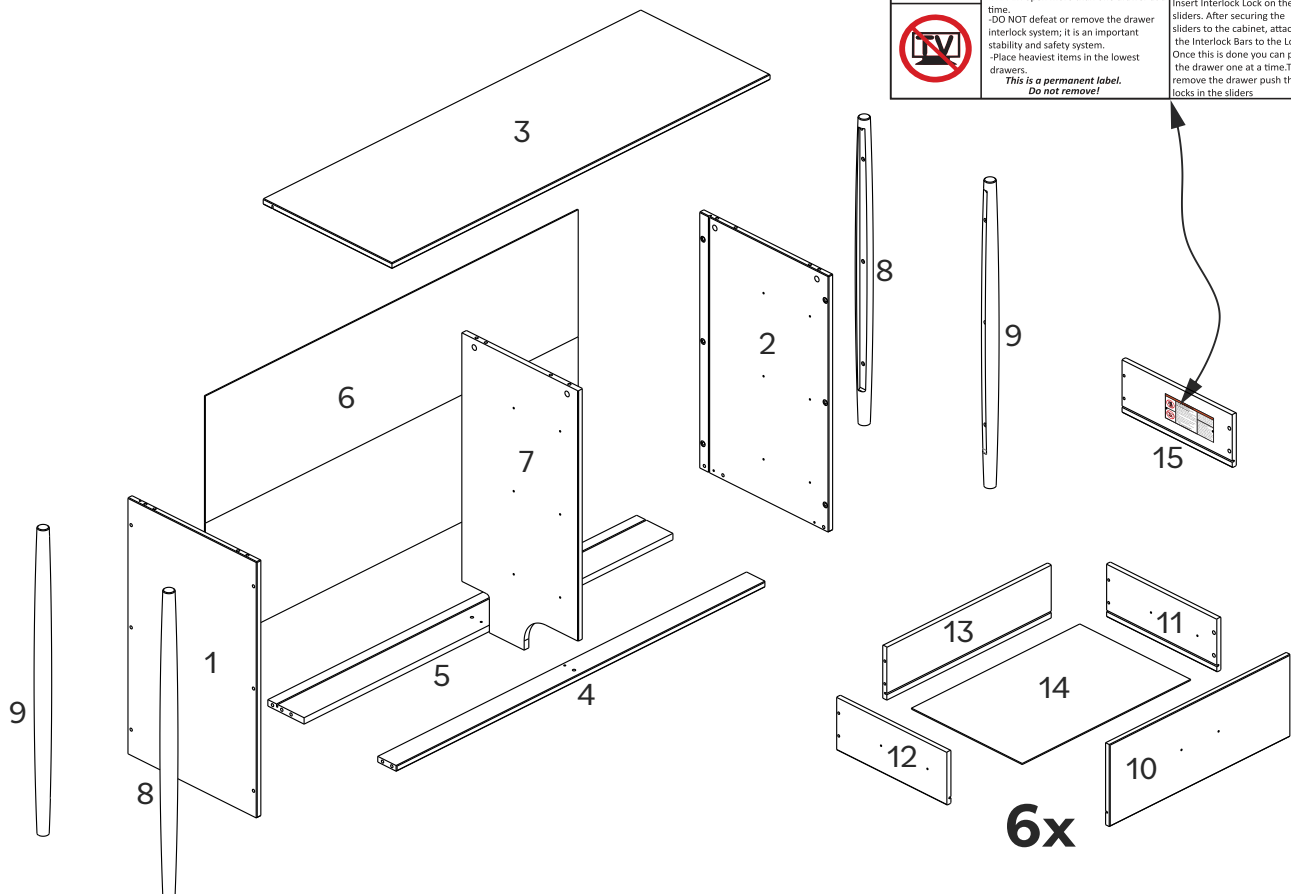







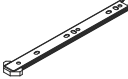

Le tiroir avec
**L'ÉTIQUETTE
D'AVERTISSEMENT**
doit être placé
comme tiroir le plus
haut.

El cajón con
**ETIQUETA DE
ADVERTENCIA**, debe
colocarse como el
cajón más alto.

⚠ WARNING	
 	<p>Children have died from furniture tipover. To reduce the risk of furniture tipover:</p> <ul style="list-style-type: none"> -ALWAYS install anti tip device provided. -NEVER put a TV on this product. -NEVER allow children to stand, climb or hang on any drawers, doors, or shelves. -NEVER open more than one drawer at a time. -DO NOT defeat or remove the drawer interlock system: it is an important stability and safety system. -Place heaviest items in the lowest drawers. <p><i>This is a permanent label. Do not remove!</i></p>
	<p>DO NOT remove the interlock system except for maintenance as shown. NEVER use the unit without the interlock installed following the instructions System Specific Instructions for Interlock Installation. Insert Interlock Lock on the sliders. After securing the sliders to the cabinet, attach the Interlock Bars to the Locks. Once this is done you can place the drawer one at a time. To remove the drawer push the locks in the sliders.</p>

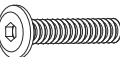

Liste de composants / Lista de hardware

Partie Parte	Taille Tamaño	Nom Nombre	Quantité Cantidad
A 		Dovetail Dovetail	12
B 		Dovetail Lock Dovetail Lock	24
C 		Vis en Plastique Tornillo Plástico	24
D 	6x12mm	Vis Tornillo	24
E 		Interlock Lock Interlock Lock	12
F 	3,5x30mm	Vis Tornillo	12
G1 	250mm	Glissière Extérieur Corredera Exterior	12
G2 	250mm	Glissière Intérieur Corredera Interior	12
H 		Poignée Manija	6
I 	8x30mm	Cheville Espiga	14
J 		Douille Plastique Casquillo Plástico	1
K 		Pied Réglable Pata Ajustable	1
L 	6x31mm	Goujon Conector	10
M 	15x11mm	Boitier Traba	10
N 		Interlock Bar InterlockBar	8
O 	7x35mm	Boulon Perno	12
P 	4x40mm	Vis Tornillo	3







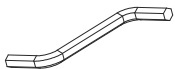

Les quantités de composants indiquées ci-dessus sont nécessaires pour un assemblage correct.

Des pièces supplémentaires peuvent être incluses.

Las cantidades de tornillería indicadas anteriormente son necesarias para un montaje correcto.

Se pueden incluir piezas de ferretería adicionales.

Hardware List

Part	Size	Name	Quantity
Q		Clé Hex Llave Hex	1
R		Wedge Wedge	14
S		Rubán Cinta	1
T		4x16mm Vis Tornillo	1
U		6x35mm Douille Casquillo	1
V		Rondelle Arandela	2
X		6x14mm Vis Tornillo	24
Z		3,5X14mm Screw	14

*The hardware quantities listed above are required for proper assembly.
Extra hardware pieces may be included.*

Introduction pour un assemblage facile du système de tiroirs

Dis adieu au tracas de l'assemblage !

Nous comprenons que l'assemblage des tiroirs peut être la partie la plus longue et la plus fastidieuse de l'assemblage de tes nouveaux meubles. C'est pourquoi nous avons développé le système de tiroirs d'assemblage facile - pour rendre le processus plus facile !

Dovetail Verrouillage Traba

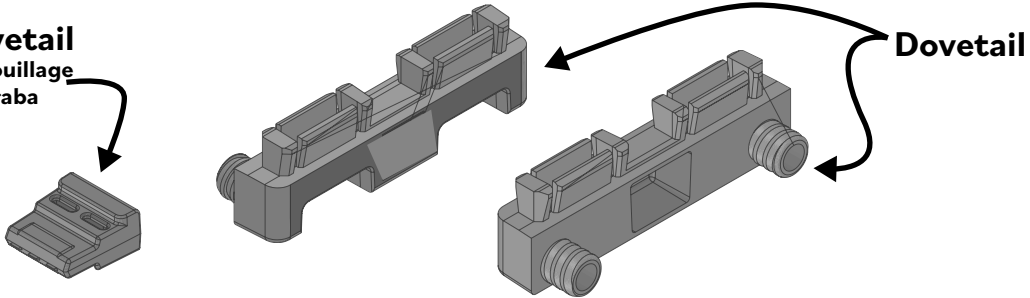

Pourquoi tu vas adorer notre système de tiroirs d'assemblage facile :

Rapide et facile : notre nouveau système de tiroir réduit considérablement le temps d'assemblage. Fais-le vite !

Effort minimal requis : Conçu pour être extrêmement simple, tu n'auras besoin que de peu ou pas d'outils pour effectuer le travail.

Construit pour durer: Solide et résistant, notre système garantit que tes tiroirs restent solides et fiables.

Préparons le scénario pour l'assemblage :

Step 1: Prépare-toi -

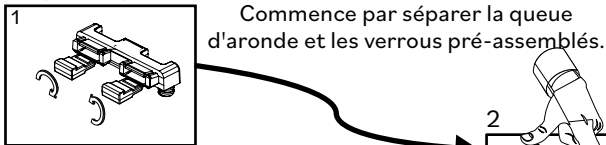

Commence par séparer la queue d'aronde et les verrous pré-assemblés.

Step 2: Jonction -
Combine la queue d'aronde avec les côtés du tiroir comme indiqué sur l'illustration.

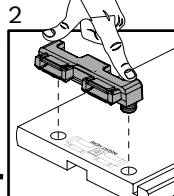

Step 3: Glisse dans la rainure -
Fais glisser la queue d'aronde dans les rainures de la face avant des tiroirs.

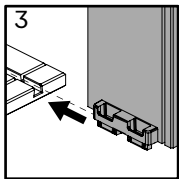

Step 4: Verrouillage -
Après avoir installé le fond du tiroir, verrouille la queue d'aronde à l'aide des loquets à queue d'aronde

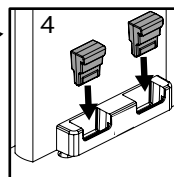

Attention : Lors des prochaines étapes, tu trouveras plus de détails pour t'aider durant l'assemblage.

Introducción al Sistema de Fácil Montaje de Cajones

¡Despídete de las complicaciones del montaje!

Entendemos que ensamblar cajones puede ser la parte más lenta y tediosa de ensamblar tus muebles nuevos. Es por eso que desarrollamos el Sistema de Cajones de Montaje Fácil, ¡para facilitar el proceso!

Por qué te encantará nuestro sistema de cajones fácil de montar:

Rápido y fácil: nuestros nuevos herrajes para cajones reducen significativamente el tiempo de montaje. ¡Hazlo rápido!

Mínimo esfuerzo requerido: Diseñado para ser muy simple, necesitarás pocas o ninguna herramienta para hacer el trabajo.

Fabricado para durar: Fuerte y resistente, nuestro sistema garantiza que tus cajones permanezcan sólidos y confiables.

Preparamos el espacio para el montaje:

Step 1: ¡Prepárate! -

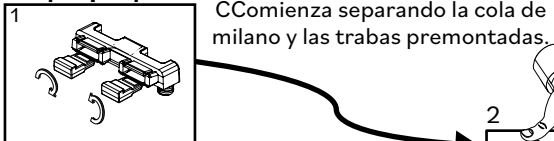

Comienza separando la cola de milano y las trabas premontadas.

Step 2: Unión -
Combina la cola de milano con los lados del cajón, como se muestra en la ilustración.

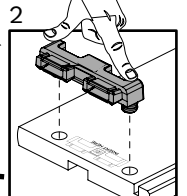

Step 3: Desliza en la ranura -
Desliza la cola de milano en las ranuras de los frentes de los cajones.

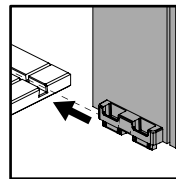

Step 4: Traba -
Después de colocar la parte inferior del cajón, bloquea la cola de milano usando las trabas de cola de milano.

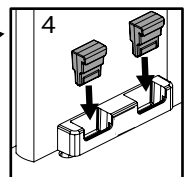

Atención: En los próximos pasos, hay más detalles para ayudarte con el montaje.

Étape / Paso 1

(FR)

Préparez les Dovetails (A) en retirant les Dovetail verrous (B) des Dovetails (A).

(ES)

Prepare las Dovetails (A) quitando las Trabas del Dovetail (B) de los Dovetails (A).

1st

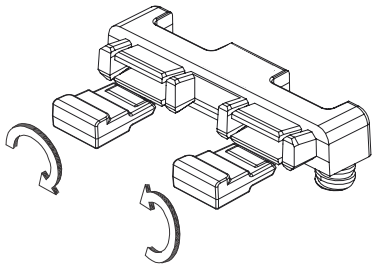

2nd

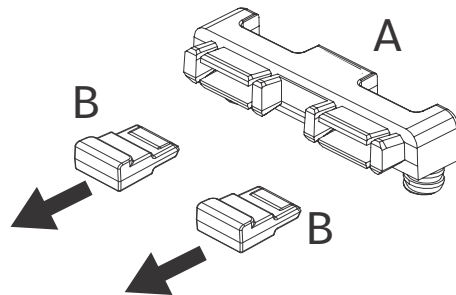

Étape / Paso 2

(FR)

Enclenchez les Dovetails (A) sur les côtés droit (11 et 15) et gauche (12) du tiroir. Appuyez sur les Dovetails jusqu'à ce qu'elles soient bien fixées. Utilisez un marteau si nécessaire.

(ES)

Coloque los Dovetails (A) en su lugar en los laterales derechos (11 y 15) e izquierda (12) del cajón. Presione los Dovetails hasta que queden completamente fijadas. Use un martillo si es necesario.

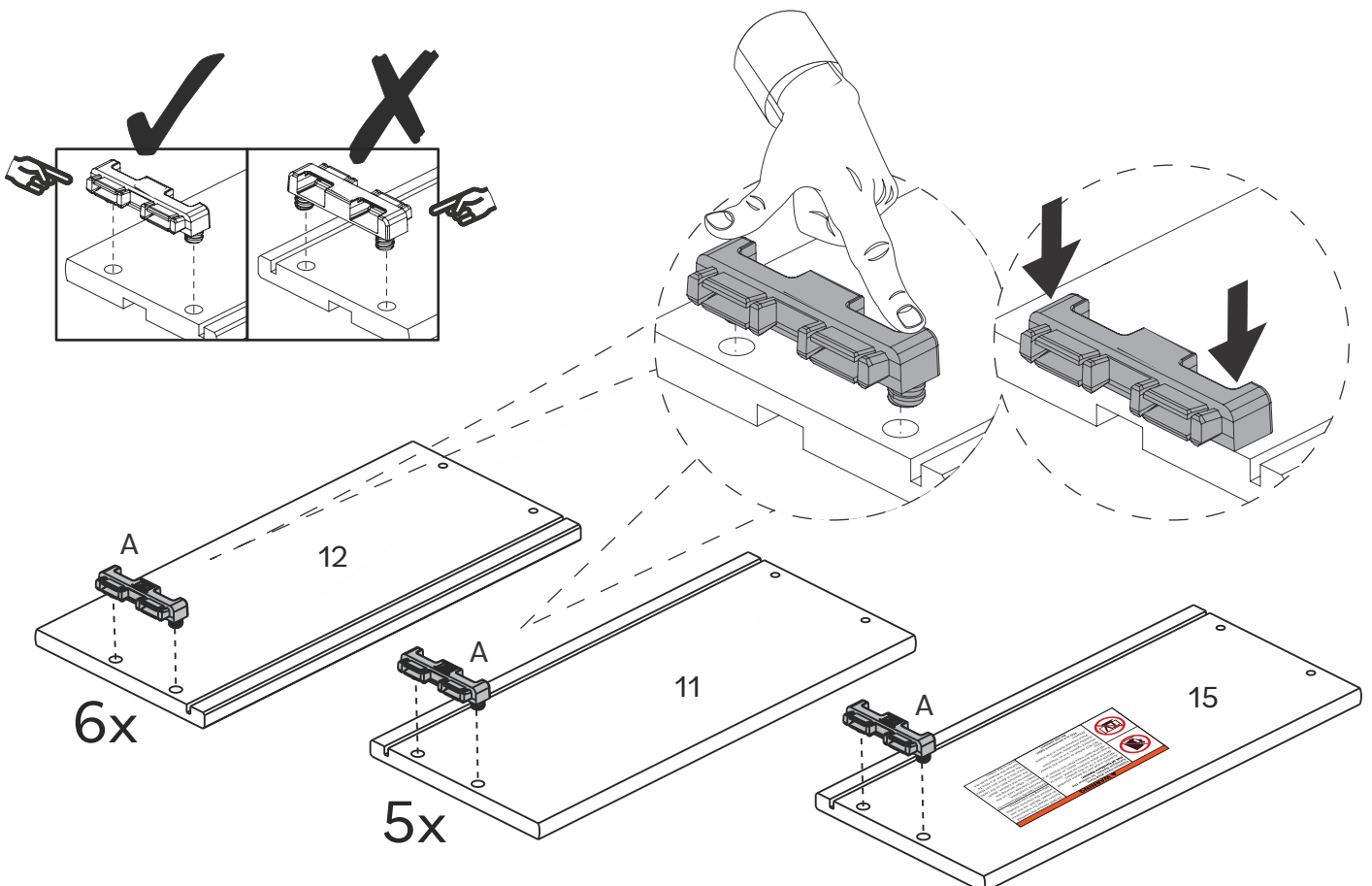

Étape / Paso 3

(FR)

Faites glisser la dovetail (A) du côté de tiroir droit (11/15) et du côté de tiroir gauche (12) dans les rainures de la façade du tiroir (10).

(ES)

Deslice la Dovetail (A) del lado derecho (11/15) y del lado izquierdo (12) del cajón en las ranuras del frente del cajón (10).

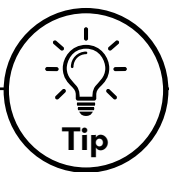
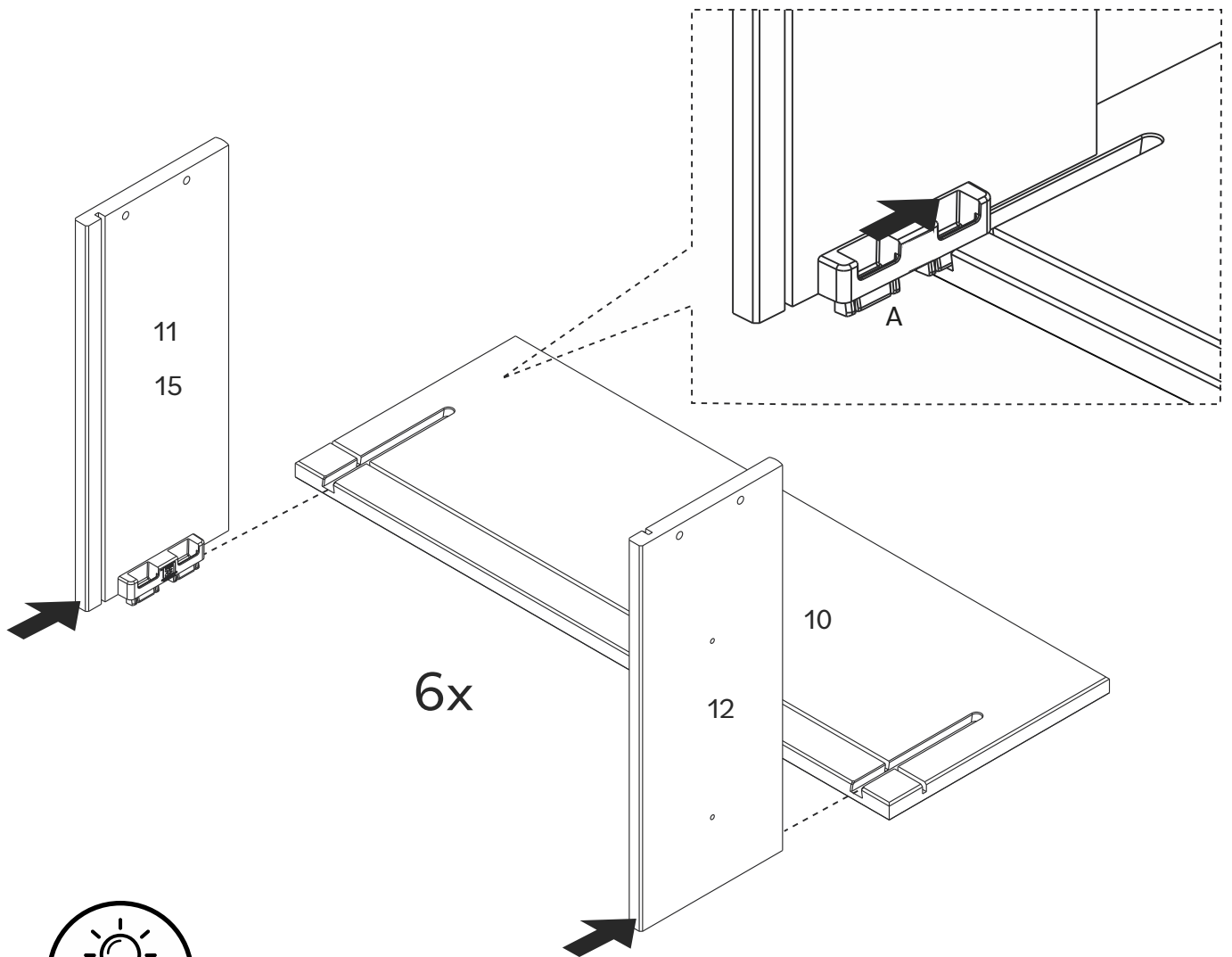

Tip

Pour que ton produit conserve son meilleur aspect et sans rayures, essaie de le monter sur une surface souple telle qu'un tapis ou une couverture. Cela permet d'éviter les rayures accidentelles et de garder tes meubles en bon état !

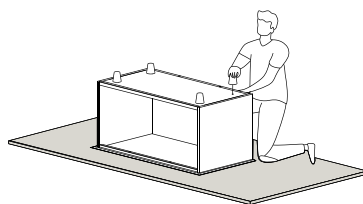

Para mantener su producto con el mejor aspecto y sin arañazos, pruebe a montarlo sobre una superficie blanda, como una alfombra o una manta. Así evitará arañazos accidentales y mantendrá sus muebles en perfecto estado.

Étape / Paso 4



(FR)

Faites glisser le fond du tiroir (14) dans les rainures du panneau de tiroir droit (11/15), du panneau de tiroir gauche (12) et de la façade du tiroir (10).

(ES)

Deslice la parte inferior del cajón (14) en las ranuras del panel del cajón derecho (11/15), el panel del cajón izquierdo (12) y el frente del cajón (10).

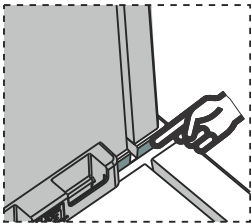

Alignez les rainures sur les côtés et le devant du tiroir pour recevoir le fond du tiroir.

Alinee las ranuras en los lados y el frente del cajón para recibir la parte inferior del cajón.

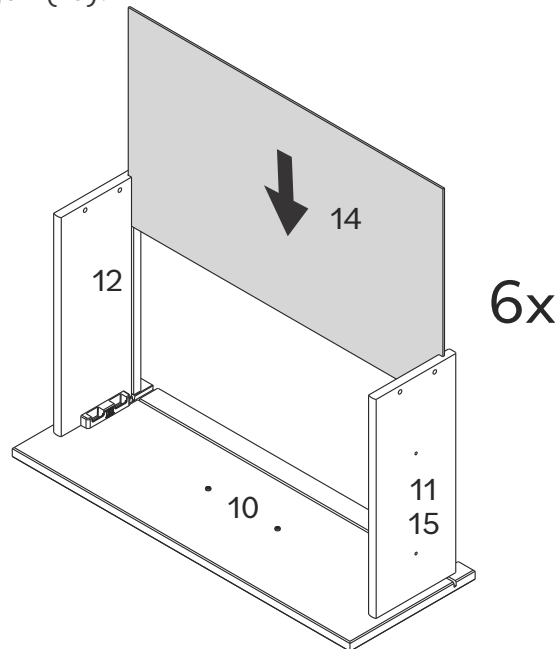

Étape / Paso 5



(FR)

Pour fixer les côtés du tiroir, insérez les Dovetail Locks (B) dans les Dovetails (A). Utilisez un marteau si nécessaire.

(ES)

Para asegurar los laterales del cajón, inserte las Dovetail Locks (B) en las Dovetails (A). Use un martillo si es necesario.

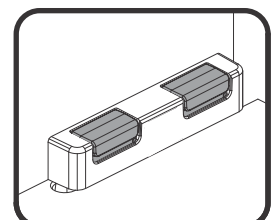
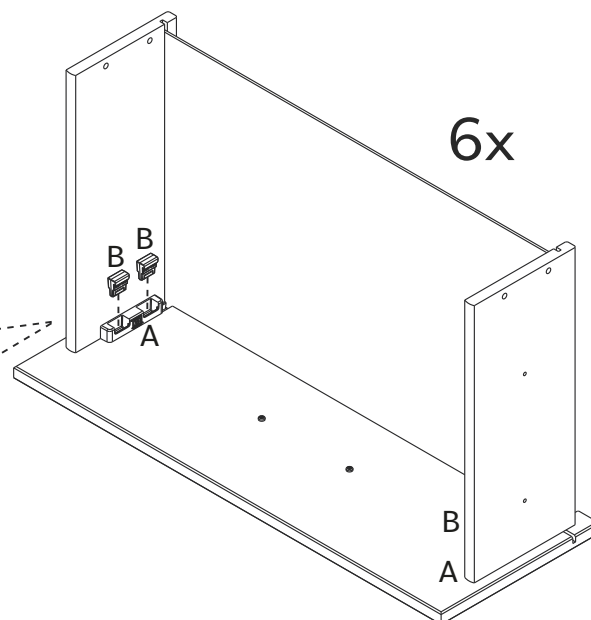
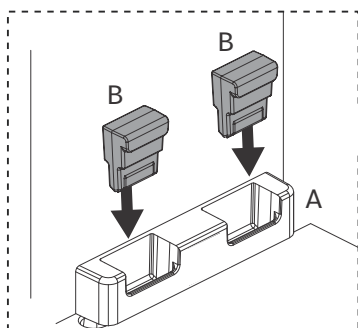

Étape / Paso 6



(FR)

Fixez le fond du tiroir (14) au arrière du tiroir (13) et fixez-le à l'aide de la vis en plastique (C). Vous pouvez l'insérer avec vos mains ou à l'aide d'un marteau.

(ES)

Coloque la parte inferior del cajón (14) en la parte posterior del cajón (13) y asegúrelo con el tornillo de plástico (C), puede insertarlo con las manos o con un martillo.

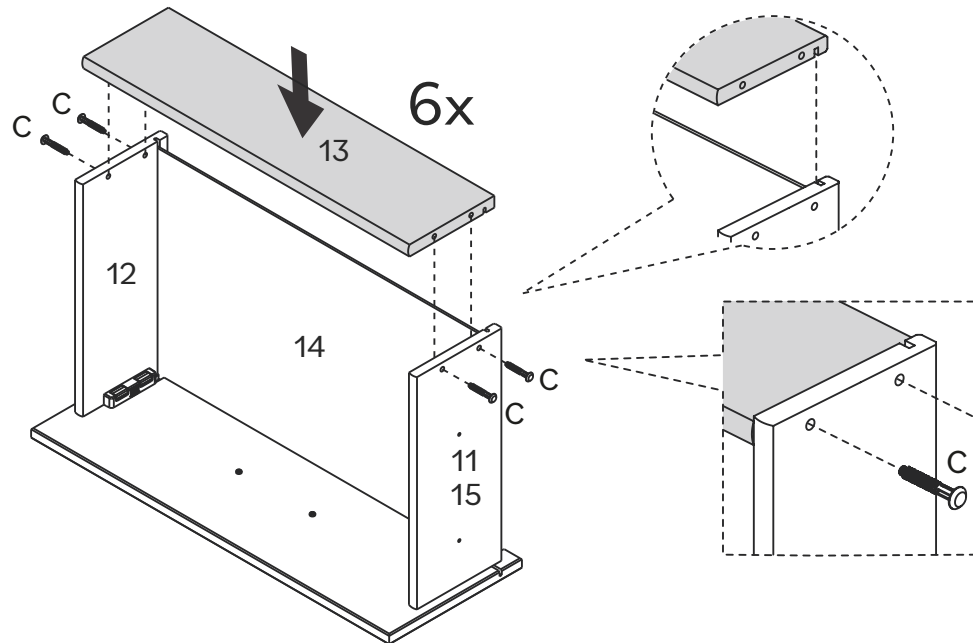

Étape / Paso 7

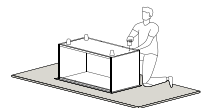

(FR)

Fixez les glissières intérieures (G2) sur les côtés droits du tiroir (11 et 15) et les côtés gauches du tiroir (12) à l'aide de la vis (D) et d'un tournevis cruciforme.

(ES)

Coloque las correderas internas (G2) en los lados del cajón derecho (11 y 15) y en los lados del cajón izquierdo (12) usando el tornillo (D) y un destornillador Phillips.

Séparer les parties G1 et G2 en appuyant sur le verrou.

Separate las piezas G1 y G2 presionando el bloqueo.

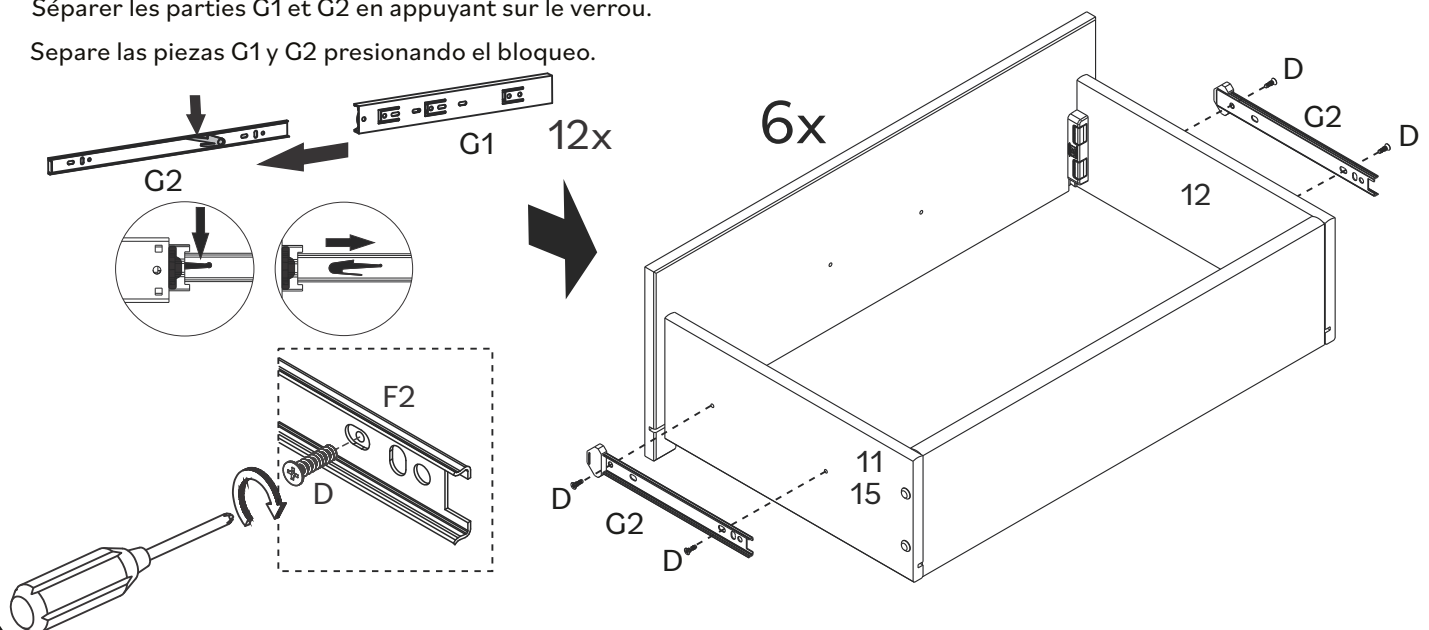

Étape / Paso 8

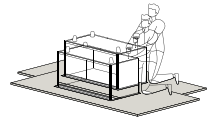

(FR)

Utilisez des vis (F) et un tournevis cruciforme pour fixer les poignées (H) aux façades des tiroirs (10).

(ES)

Utilice tornillos (F) y un destornillador Phillips para asegurar las manijas (H) a los frentes de los cajones (10).

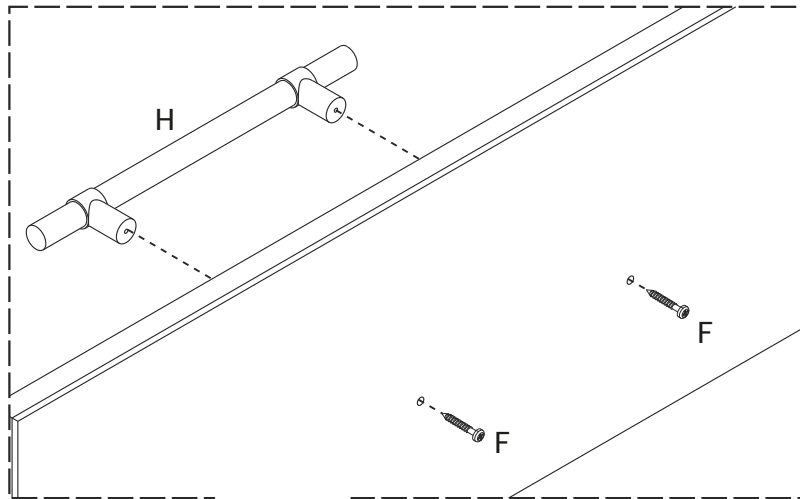

6x

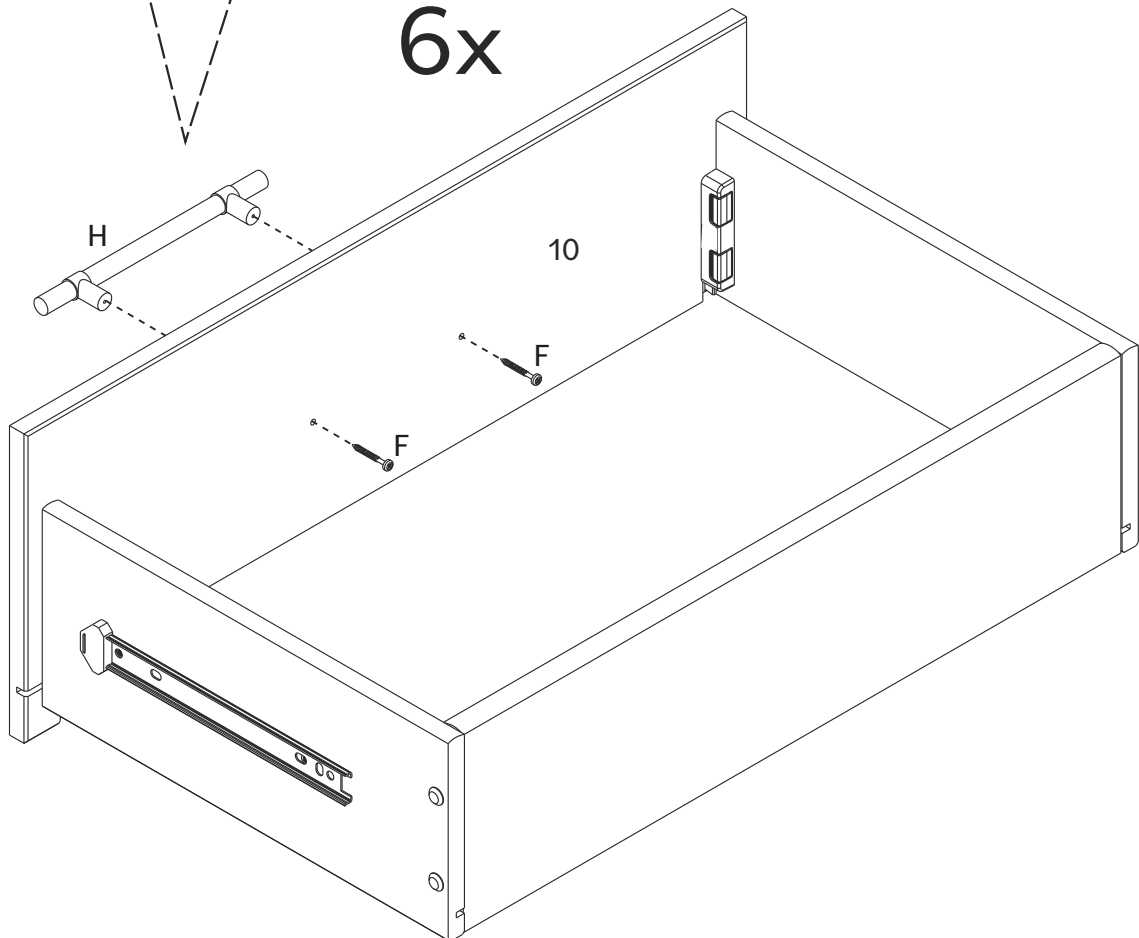

Étape / Paso 9



(FR)

Insérez les chevilles en bois (I) dans le panneau gauche (1), le panneau droit (2), le barre avant (4), le barre arrière (5) et le panneau central (7). Insérez également la douille de nivellement (J) dans le panneau central (7) et vissez le pied de nivellement (K).

(ES)

Inserte las espigas de madera (I) en el panel izquierdo (1), el panel derecho (2), el travesaño delantero (4), el travesaño trasero (5) y el panel central (7). También inserte el casquillo nivelador (J) en el panel central (7) y atornille el pie niveladora (K).

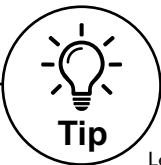
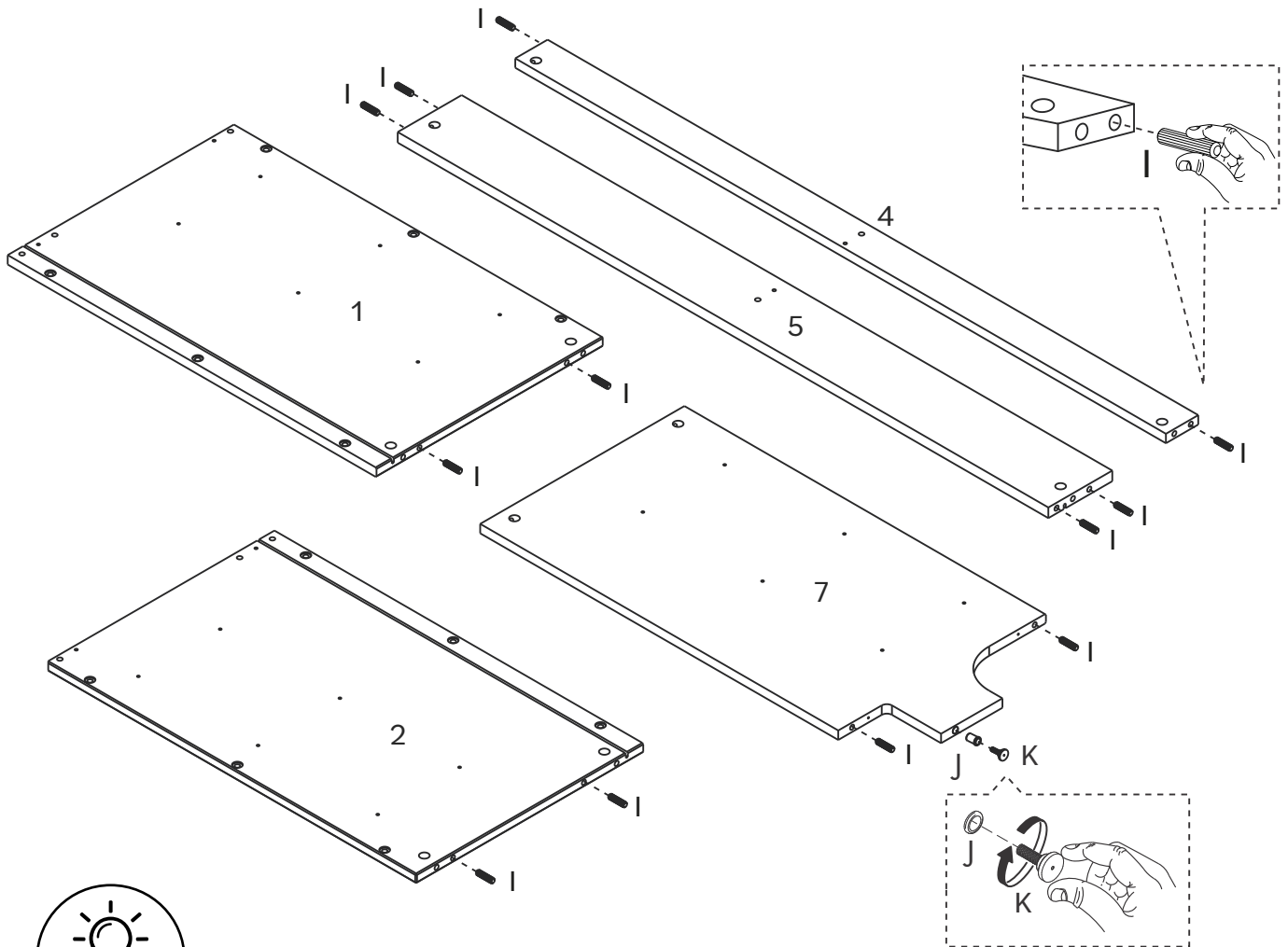

Cheville en bois

Les chevilles sont essentielles lors de l'assemblage de meubles pour créer des connexions solides et précises. Elles garantissent l'intégrité structurelle, empêchent les déplacements et simplifient l'alignement, ce qui permet d'obtenir des meubles plus résistants et plus durables. suis ces étapes :

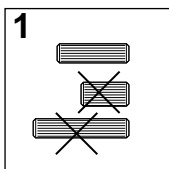

- 1: Sélectionne la taille de cheville appropriée en fonction de l'étape.
- 1: Seleccione el tamaño de espiga adecuado según el paso.

Espiga de madera

Las espigas son esenciales en el montaje de muebles para crear uniones fuertes y precisas. Garantizan la integridad estructural, evitan el desplazamiento y simplifican la alineación, lo que se traduce en muebles más resistentes y duraderos.

Sigue estos pasos:

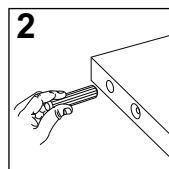

- 2: Insère dans le trou indiqué et appuie fermement pour assurer un positionnement correct.
- 2: Insértela en el orificio indicado y presione firmemente para asegurar su correcta colocación.

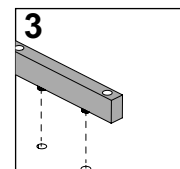
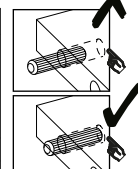

- 3: Alinee la cheville avec la pièce correspondante et enfonce-la jusqu'à ce qu'elle soit ferme.
- 3: Alinee el pasador con la pieza correspondiente y presiónelo hasta que encaje.

Étape / Paso 10

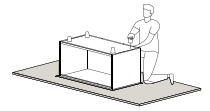

(FR)

Fixez les goujons (L) au panneau gauche (1), au panneau droit (2) et au panneau supérieur (3) à l'aide d'un tournevis cruciforme.

(ES)

Coloque los conector (L) en el panel izquierdo (1), el panel derecho (2) y el panel superior (3) usando un destornillador Phillips.

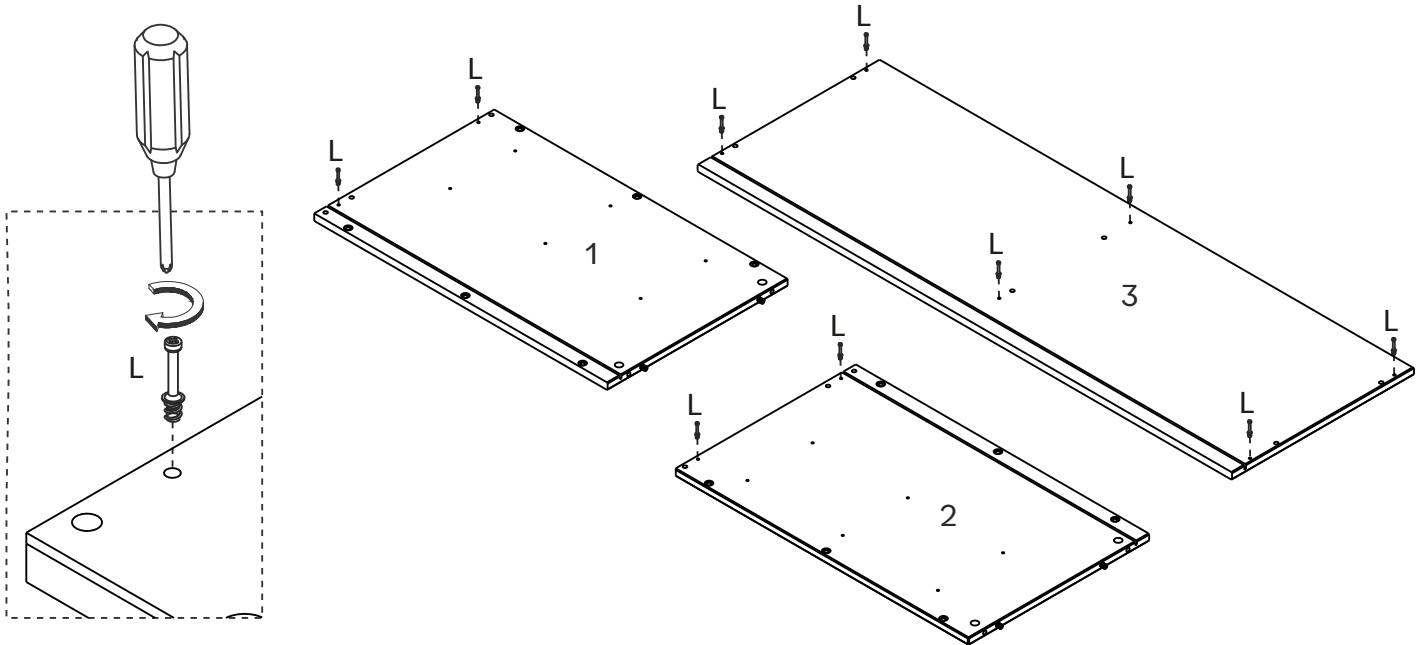

Étape / Paso 11



(FR)

Prenez le glissière extérieure (G1) et insérez le verrou Interlock (E) conformément au schéma ci-dessous.

(ES)

Tome la corredera externo (G1) e inserte el traba del interlock (E) de acuerdo con el diagrama a continuación.

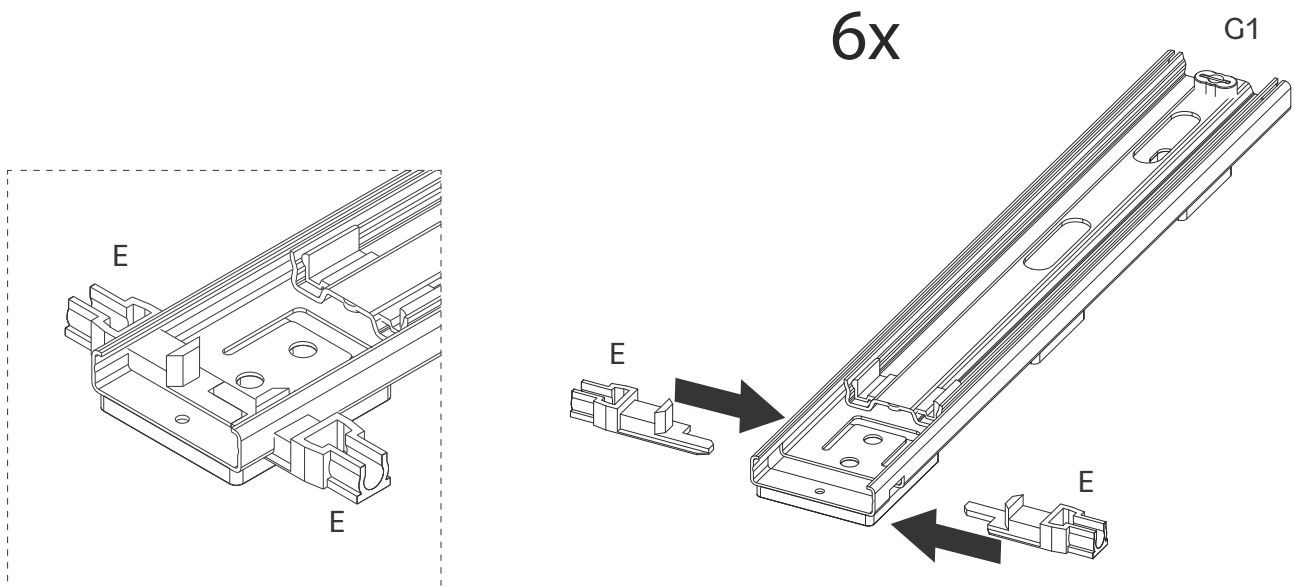

Étape / Paso 12



(FR)

Fixez le glissière extérieure (G1) au panneau droit (2) et au panneau gauche (1) à l'aide de la vis (X) et d'un tournevis cruciforme.

(ES)

Asegure la corredera exterior (G1) al panel derecho (2) y al panel izquierdo (1) usando el tornillo (X) y un destornillador Phillips.

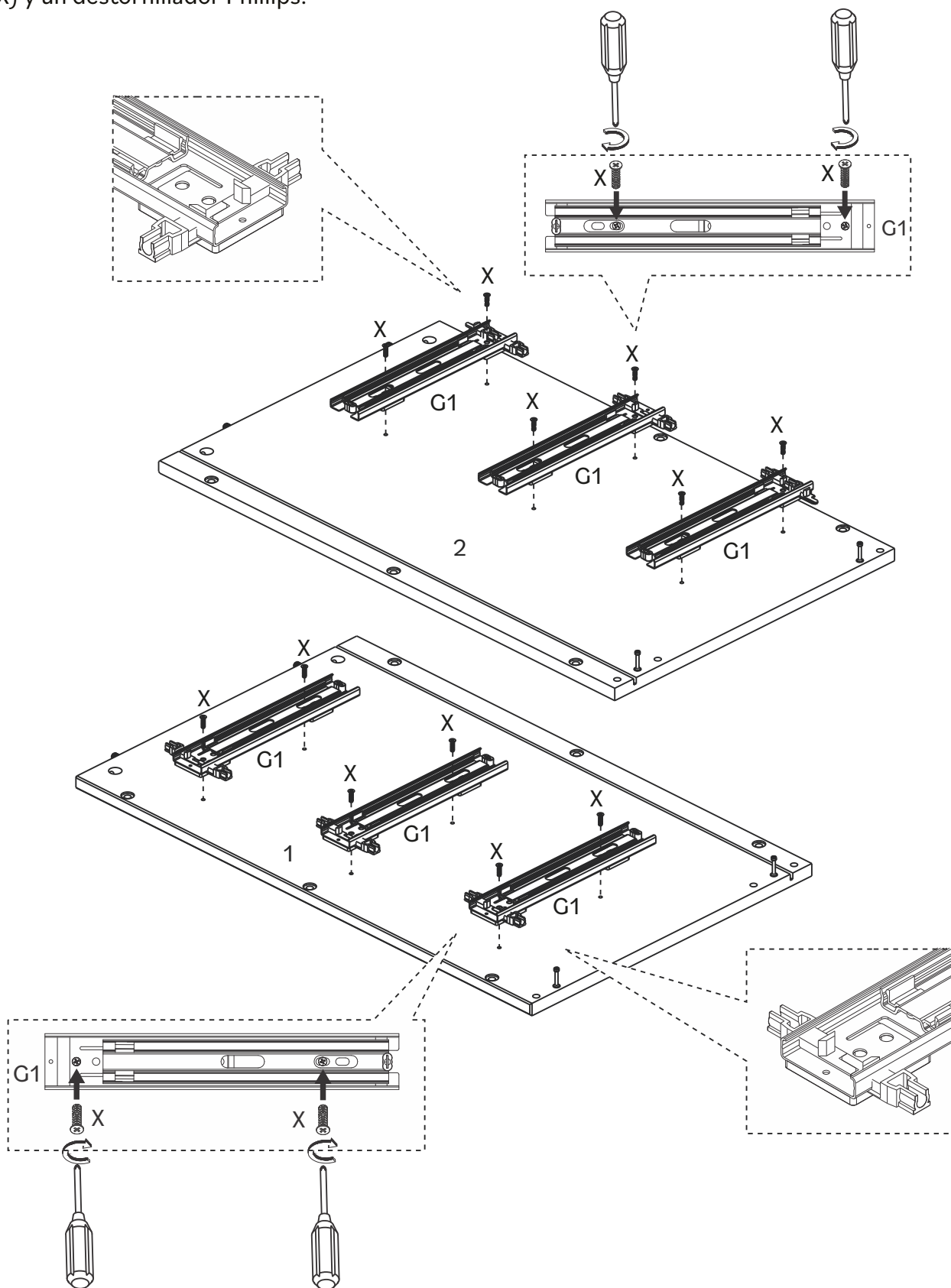

Étape / Paso 13



(FR)

Fixez le glissière extérieure (G1) des deux côtés du panneau central (7) à l'aide de la vis (X) et d'un tournevis cruciforme.

(ES)

Asegure la corredera exterior (G1) a ambos lados del panel central (7) usando el tornillo (X) y un destornillador Phillips.

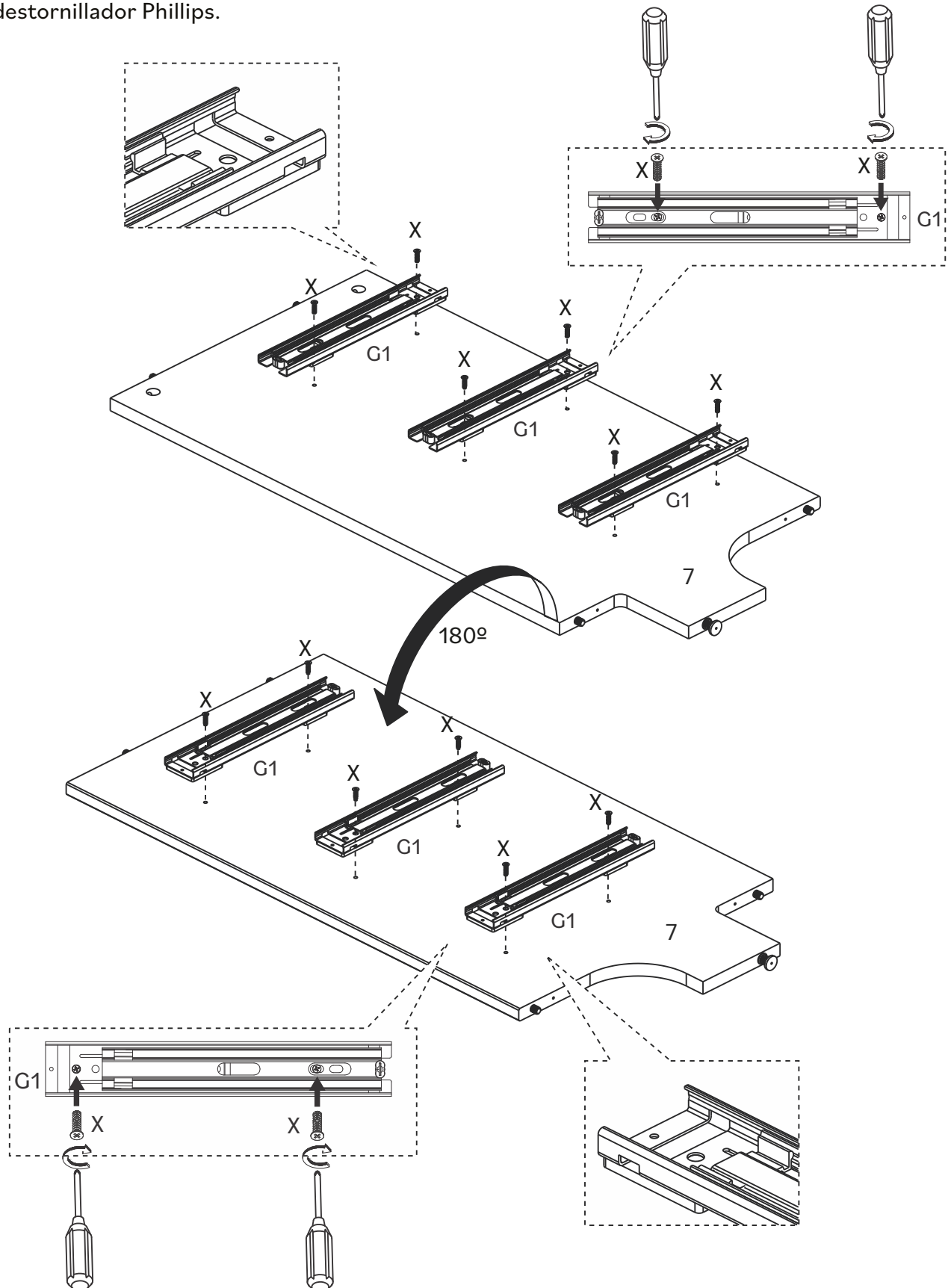

Étape / Paso 14

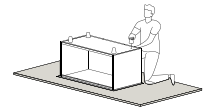

(FR)

Fixez le panneau supérieur (3) au panneau gauche (1) à l'aide des boîtiers (M) et d'un tournevis cruciforme.

(ES)

Conecte el panel superior (3) al panel izquierdo (1) usando trabas (M) y un destornillador Phillips.

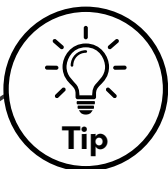
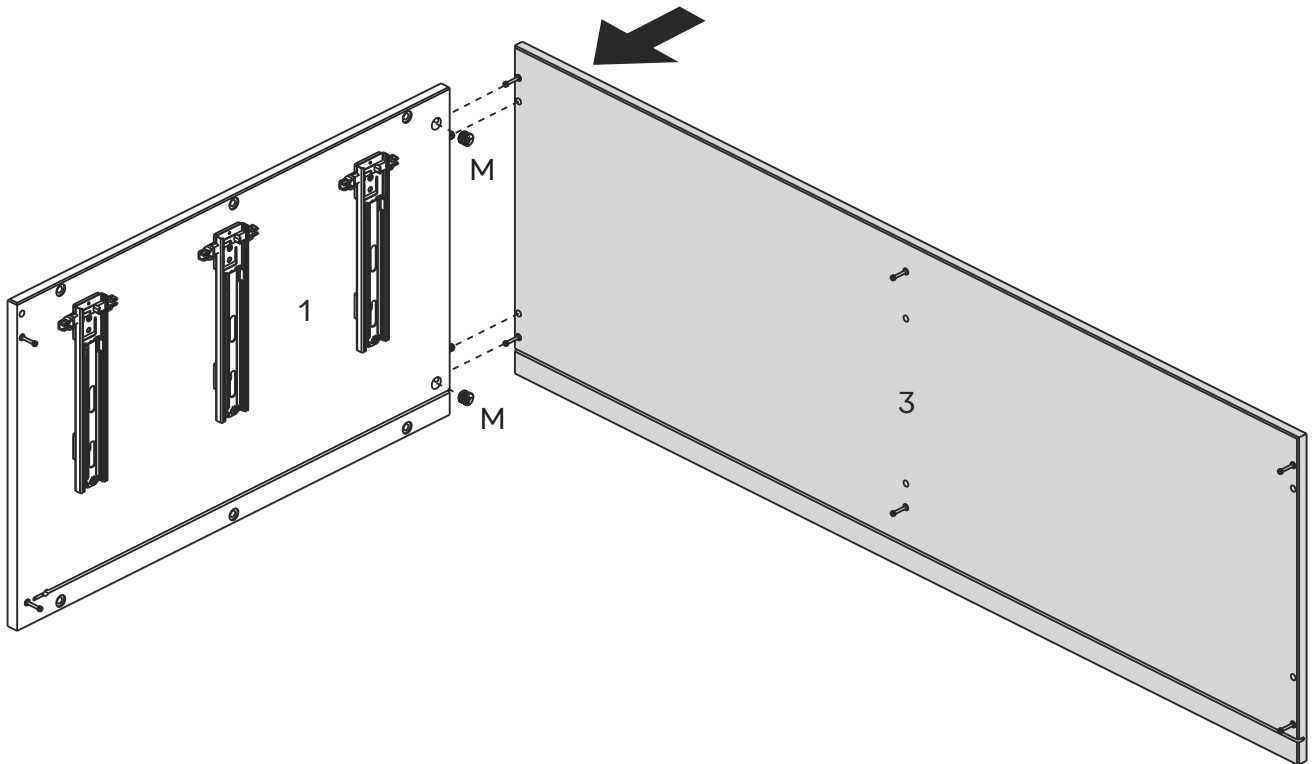

Tip

Goujon de Assemblage

Goujon de Assemblage permet de joindre deux pièces en toute sécurité. Suis ces étapes simples.

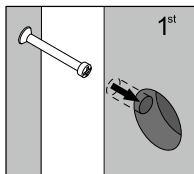

1: Insère le Goujon dans les orifices du côté plat. Ne serre pas trop !

1: Coloca el Conector en los orificios del lado plano. ¡No aprietes demasiado!

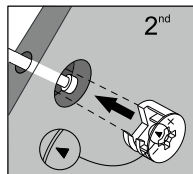

2: Joins les pièces en bois. Les Goujons entrent dans les orifices qui ont des trous sur les côtés, tu dois pouvoir voir les Goujons à travers ceux-ci. Après avoir installé les pièces, insère le Boîtiers dans les orifices latéraux

2: Una las piezas de madera. Los Conectores entran en las piezas que tienen orificios en los lados, por lo que deberías poder ver los Conectores a través de ellos. Después de encajar las piezas, inserta la traba en los orificios laterales.

Conector

Los Conector ayudan a unir de forma segura dos piezas. Sigue estas fáciles etapas.

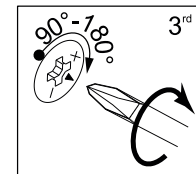

3: Sur la partie arrière du boîtier, il aura la forme d'un « C ». Insère le boîtier de manière à ce que l'ouverture « C » s'emboîte à la goujon. Serre-la avec le tournevis.
3: La parte posterior de la traba tendrá la forma de "C". Inserta el tambor de modo que la abertura de la "C" encaje en el Conector. Apriétalo con un destornillador.

Étape / Paso 15



(FR)

Fixez le panneau central (7) au panneau supérieur (3) à l'aide des boitiers (M) et d'un tournevis cruciforme.

(ES)

Asegure el panel central (7) al panel superior (3) usando trabas (M) y un destornillador Phillips.

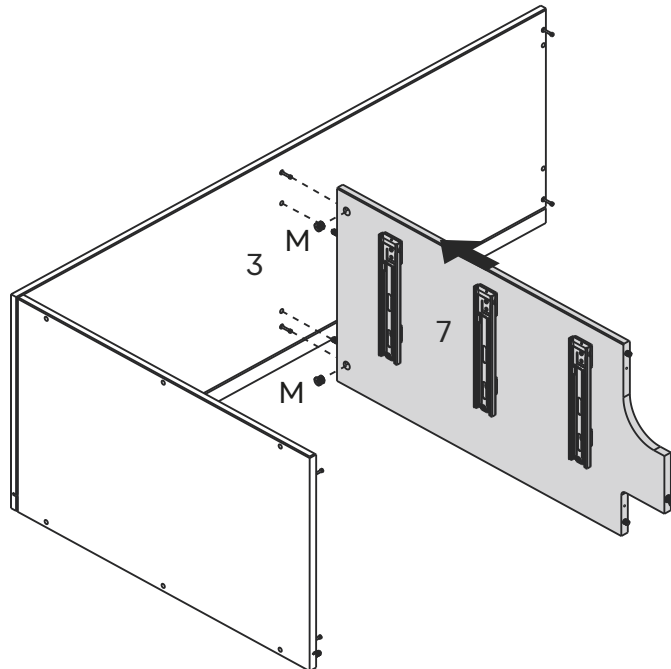
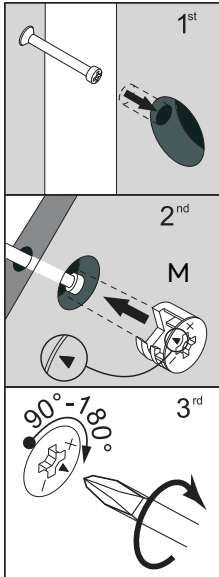

Étape / Paso 16

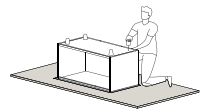

(FR)

Joignez le rail arrière (5) au panneau gauche (1) et au panneau central (7) à l'aide du boîtier (M) avec vis (P) et d'un tournevis cruciforme.

(ES)

Una el riel trasero (5) al panel izquierdo (1) y al panel central (7) usando la traba (M) con el tornillo (P) y un destornillador Phillips.

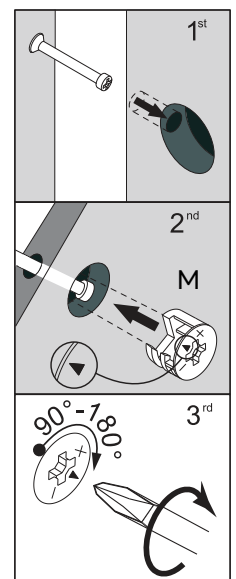
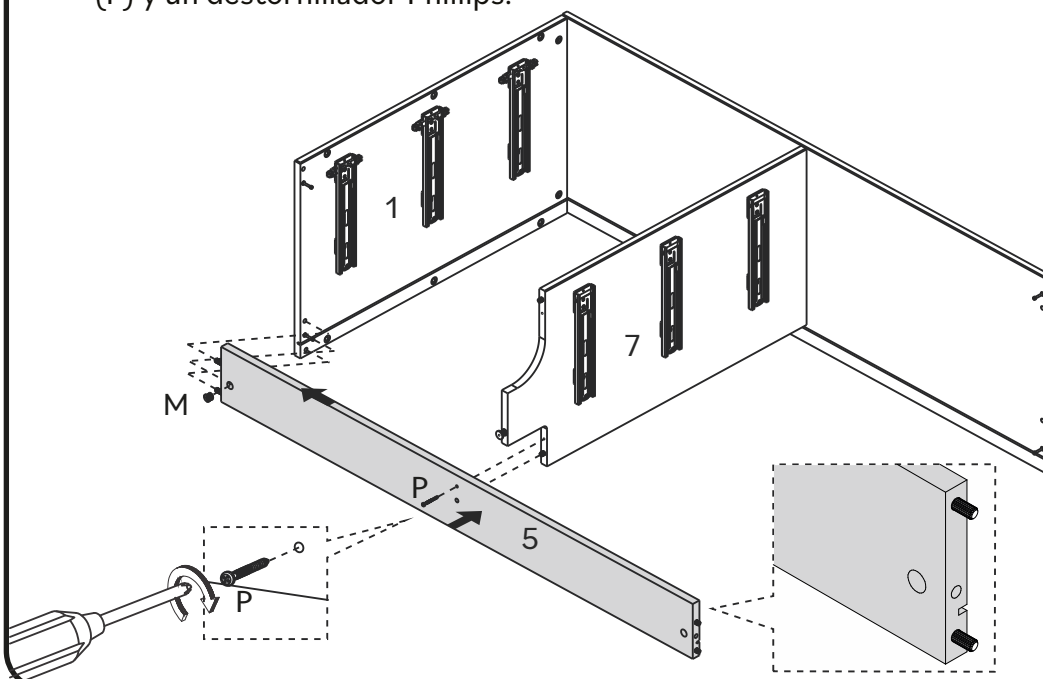

Étape / Paso 17



(FR)

Connectez le barre avant (4) au panneau gauche (1) à l'aide des boitiers (M) et au panneau central (7) avec la vis (P) et un tournevis cruciforme.

(ES)

Una el travesaño frontal (4) al panel izquierdo (1) usando trabas (M) y al panel central (7) con el tornillo (P) y un destornillador Phillips.

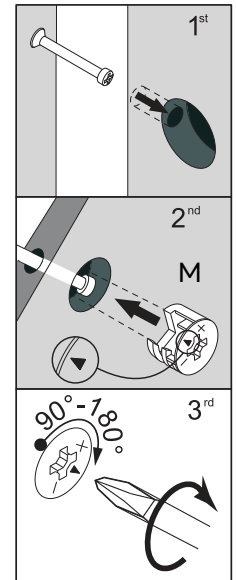
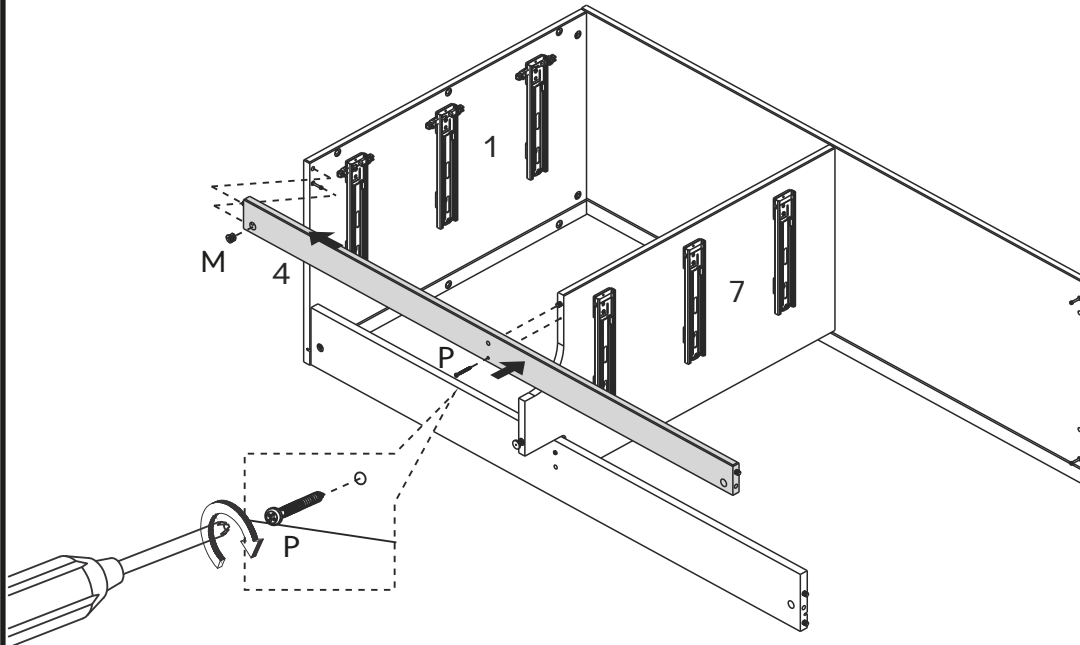

Étape / Paso 18



(FR)

Faites glisser le panneau arrière (6) sur les rainures entre le panneau supérieur (3) et le barre arrière (5), en l'insérant dans le panneau gauche (1).

(ES)

Deslice el panel posterior (6) en las ranuras entre el panel superior (3) y el travesaño trasero (5), ajustándolo en el panel izquierdo (1).

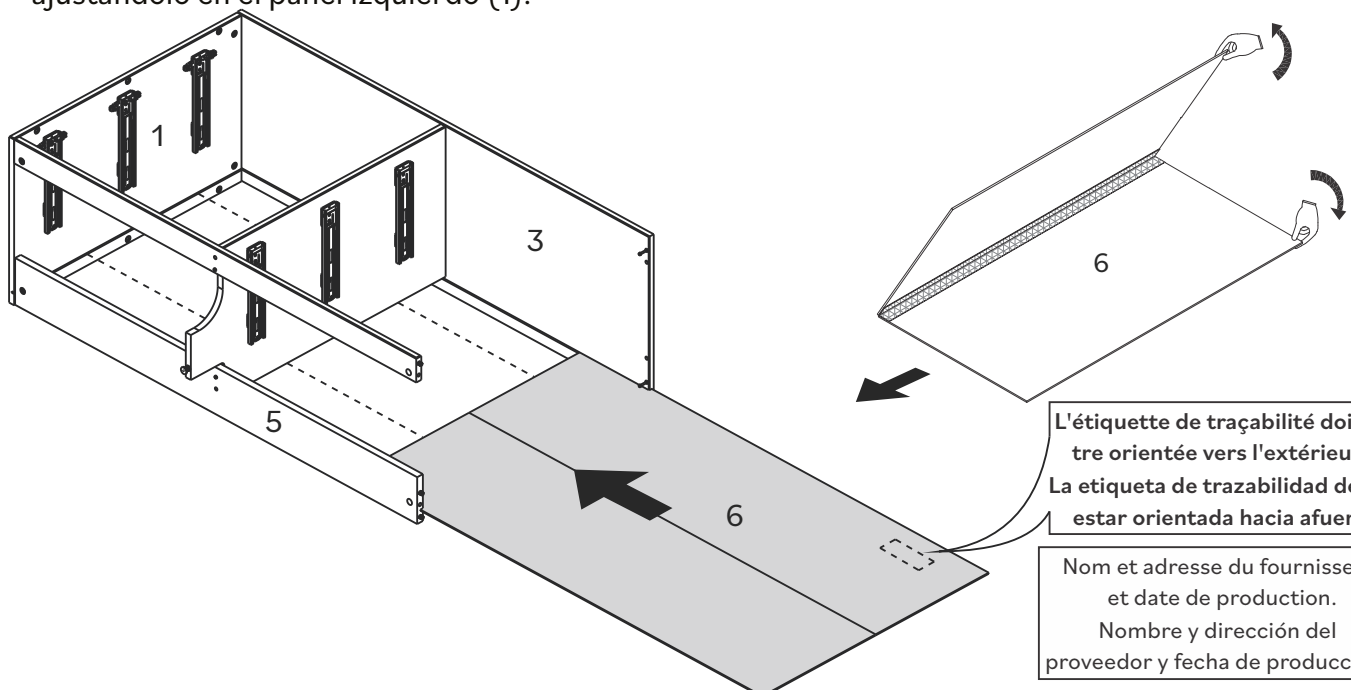

Étape / Paso 19



(FR)

Maintenant, joignez le panneau droit (2) à l'aide des boitiers (M) et d'un tournevis cruciforme.

(ES)

Ahora, una el panel derecho (2) usando las trabas (M) y un destornillador Phillips.

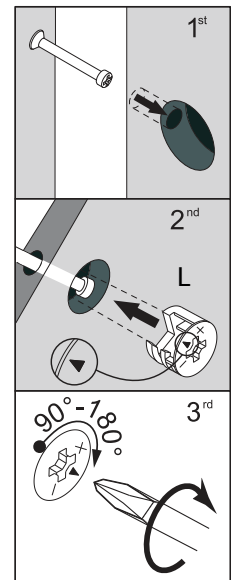
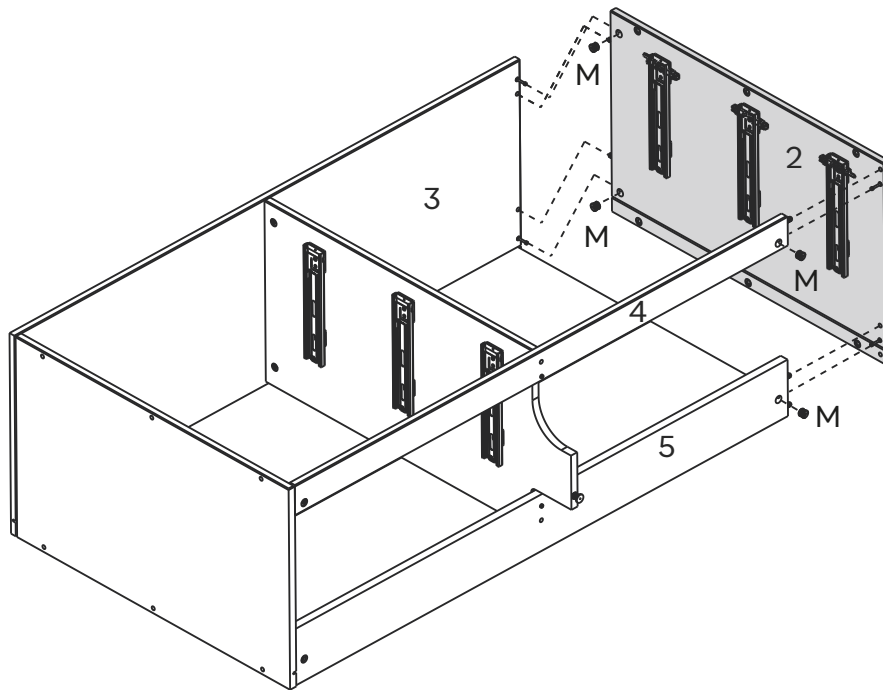

Étape / Paso 20

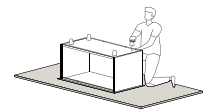

(FR)

Fixez le pied gauche (8) au panneau gauche (1) à l'aide du boulon (O) et de la clé Allen (Q). Procédez de même avec le pied droit (9) sur le panneau droit (2).

(ES)

Fije el pie izquierdo (8) al panel izquierdo (1) con el perno (O) y la llave hexagonal (Q). Haga lo mismo con el pie derecho (9) en el panel derecho (2).

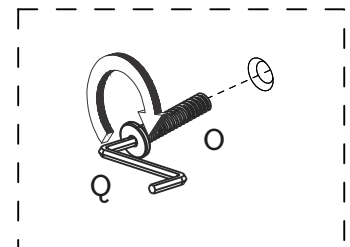
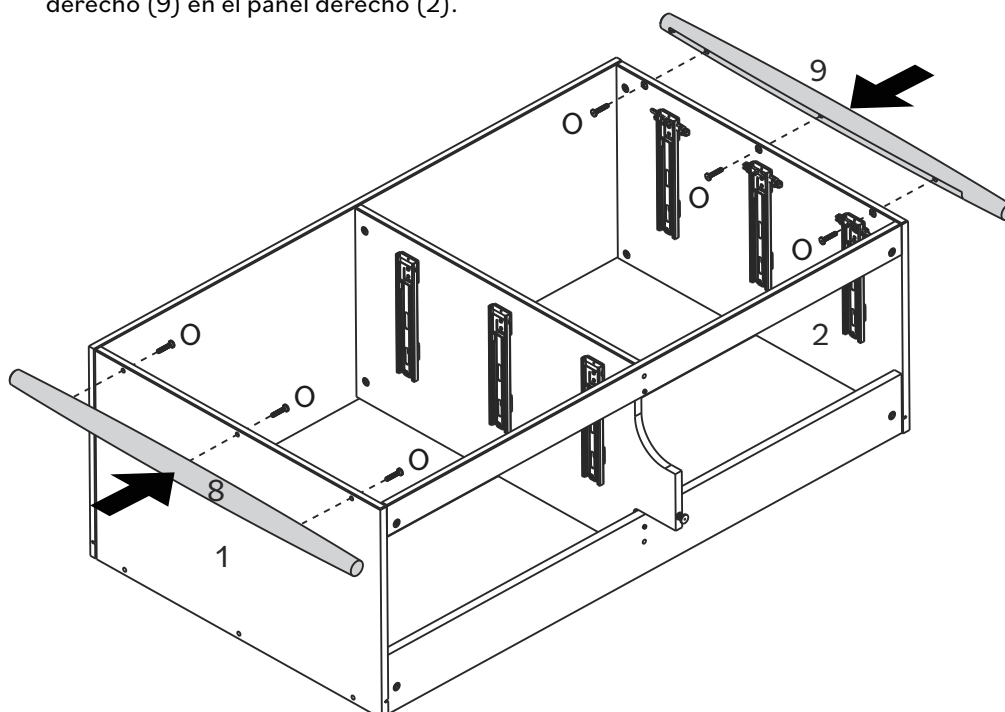

Étape / Paso 21

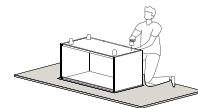

(FR)

Soulevez votre nouvelle commode et fixez le pied gauche (8) à l'autre extrémité du panneau droit (2) à l'aide du boulon (O) et de la clé Allen (Q). Procédez de même avec le pied droit (9) du panneau gauche (1)

(ES)

Levante su nueva cómoda y fije la pie izquierdo (8) al otro extremo del panel derecho (2) con el perno (O) y la llave hexagonal (Q). Haga lo mismo con la pie derecho (9) del panel izquierdo (1).

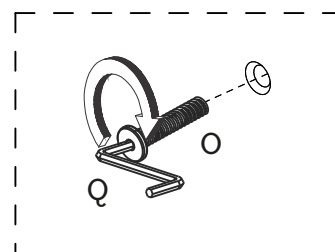
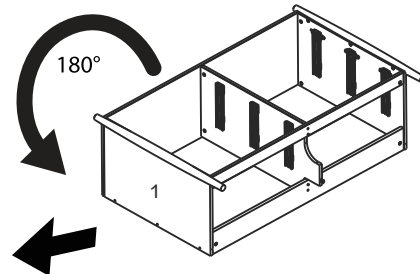
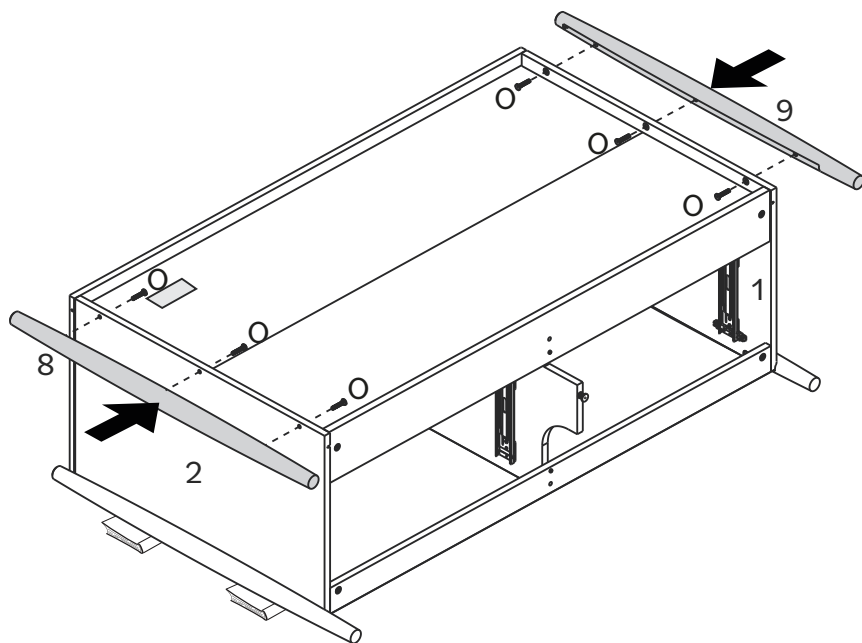

Étape / Paso 22



(FR)

Fixez le Panneau Arrière (6) en insérant la Cale (R) et la vis (Z) entre le panneau et les rainures. Utilisez un tournevis Phillips.

(ES)

Asegure el Panel Trasero (6) colocando la Cuña (R) et el tornillo (Z) entre el panel y las ranuras. Use un destornillador Phillips.

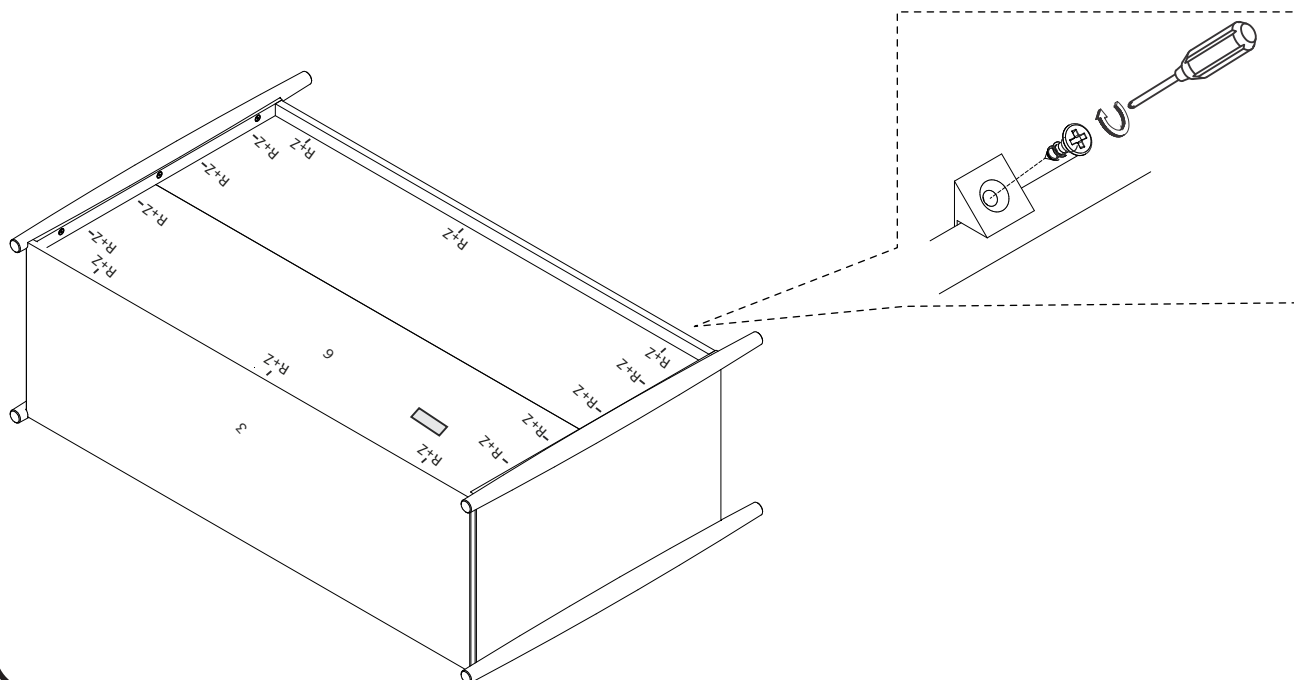

Step 23

(FR)

Fixez la Interlock Bar (E) dans les Locks (N).

(ES)

Coloque la Interlock Bar (E) en las Locks (N).

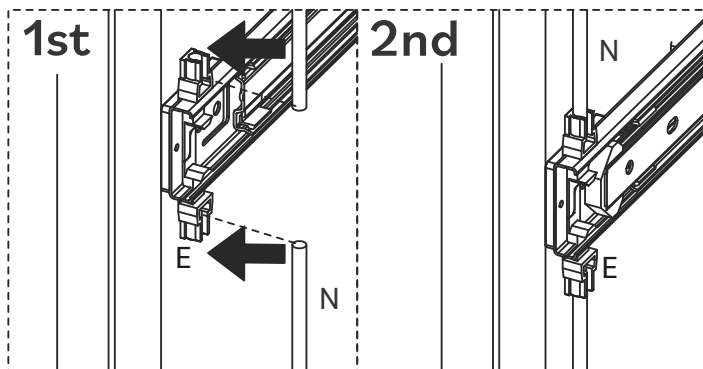
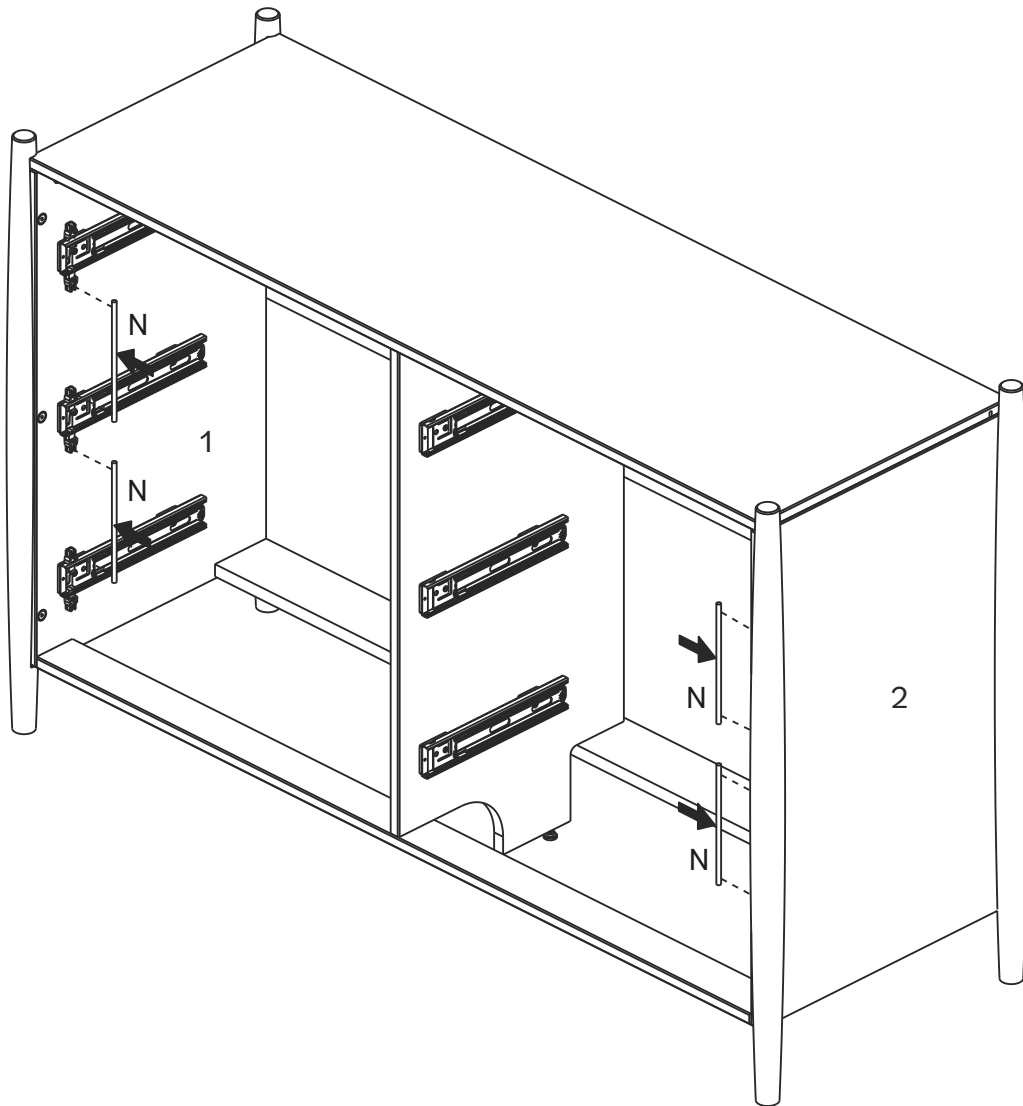

Étape / Paso 24

(FR)

Placez les tiroirs un par un à l'aide du curseur, veillez à les positionner correctement en alignant le curseur extérieur et intérieur.

(ES)

Coloque los cajones uno a uno usando el deslizador, preste atención a posicionarlos correctamente alineando el deslizador externo e interno.

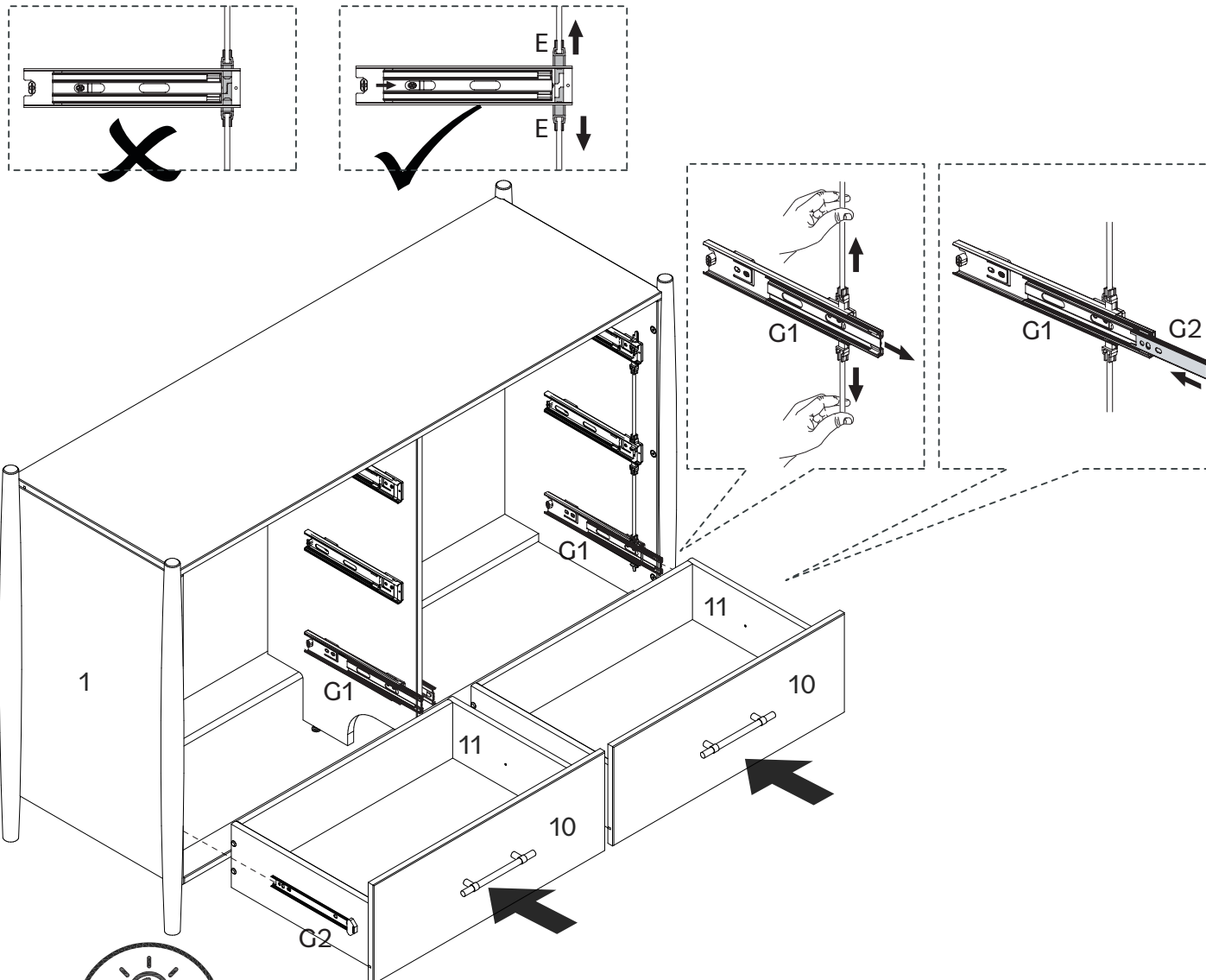

Tip

Insérez correctement le tiroir de votre armoire

Alignez les glissières extérieure et intérieure et poussez légèrement le tiroir à l'intérieur du meuble. Une fois la connexion établie, poussez le tiroir jusqu'à ce qu'il soit bien en place. Le glissement peut être délicat au début, mais il s'améliore une fois la connexion établie.

Inserte el cajón de su gabinete correctamente

Alinee las correderas exterior e interior y empuje el cajón ligeramente dentro de la unidad. Una vez que sienta la conexión, empujelo hasta que encaje completamente. Puede que al principio no se deslice con suavidad, pero mejora una vez que esté completamente conectado.

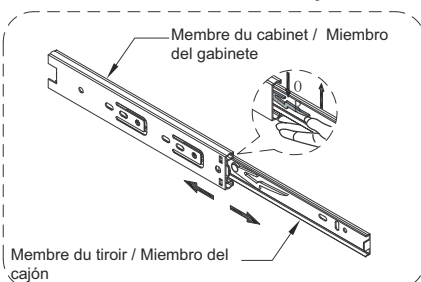

Étape / Paso 25

(FR)

Placez les tiroirs un par un à l'aide du curseur, veillez à les positionner correctement en alignant le curseur extérieur et intérieur.

(ES)

Coloque los cajones uno a uno usando el deslizador, preste atención a posicionarlos correctamente alineando el deslizador externo e interno.

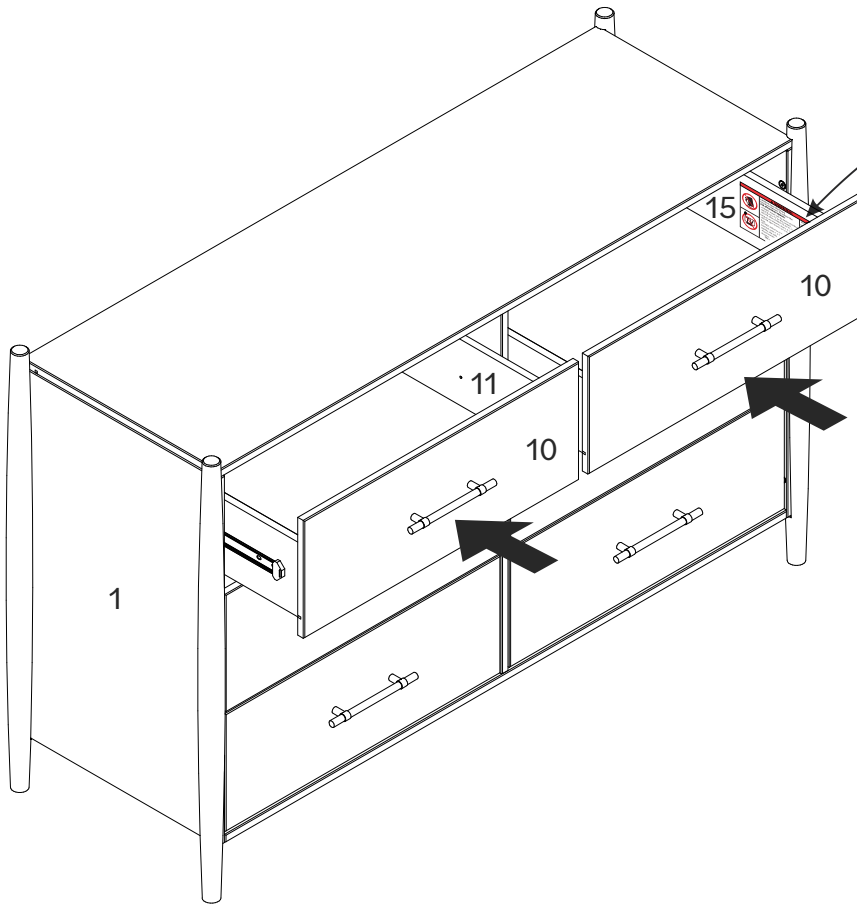

⚠ WARNING		
	<p>Children have died from furniture tipover. To reduce the risk of furniture tipover:</p> <ul style="list-style-type: none"> -ALWAYS install anti tip device provided. -NEVER put a TV on this product. -NEVER allow children to stand, climb or hang on any drawers, doors, or shelves. -NEVER open more than one drawer at a time. -DO NOT defeat or remove the drawer interlock system; it is an important stability and safety system. -Place heaviest items in the lowest drawers. <p><i>This is a permanent label. Do not remove!</i></p>	<p>DO NOT remove the interlock system except for maintenance as shown. NEVER use the unit without the interlock installed following the instructions.</p> <p>System Specific Instructions for interlock installation.</p> <p>Insert Interlock Lock on the sliders. After securing the sliders to the cabinet, attach the Interlock Bars to the Locks. Once this is done you can place the drawer one at a time. To remove the drawer push the locks in the sliders</p>

Le côté du tiroir avec l'étiquette d'avertissement doit être positionné comme le tiroir le plus haut.

El lateral del cajón con etiqueta de advertencia debe colocarse como el cajón más alto.

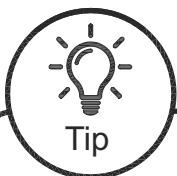
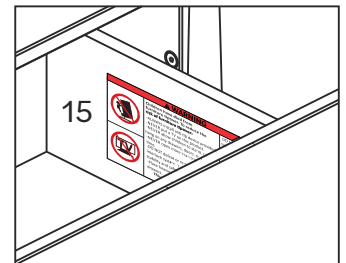

Retrait du tiroir

Il y a un levier blanc dans chaque glissière.
Pour retirer les tiroirs, tirez le tiroir jusqu'à ce que vous voyiez le levier. Poussez un levier vers le haut et l'autre vers le bas, tout en poussant, tirez le tiroir vers l'extérieur.

Extracción del cajón

Hay una palanca blanca en cada riel. Para quitar los cajones, tire del cajón hasta que vea la palanca. Empuje una palanca hacia arriba y la otra hacia abajo, y mientras empuja, saque el cajón.

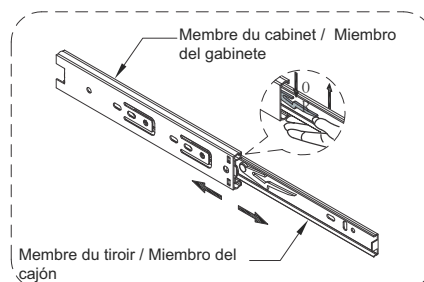

Étape / Paso 26

(FR)

Pour terminer, fixez le kit anti-basculement. Fixez l'ruban (S) au panneau supérieur (3) à l'aide d'une rondelle (V), d'une vis (T) et d'un tournevis cruciforme en suivant les instructions du schéma ci-dessous.

(ES)

Para finalizar, instale el kit antivuelco. Fije la cinta (S) al panel superior (3) con la arandela (V), el tornillo (T) y un destornillador Phillips, siguiendo las instrucciones del diagrama a continuación.

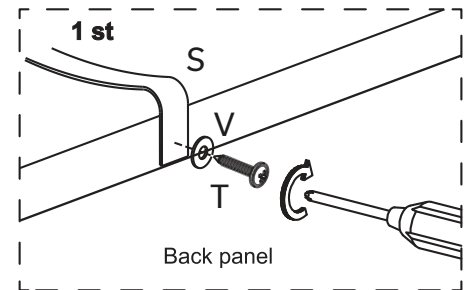
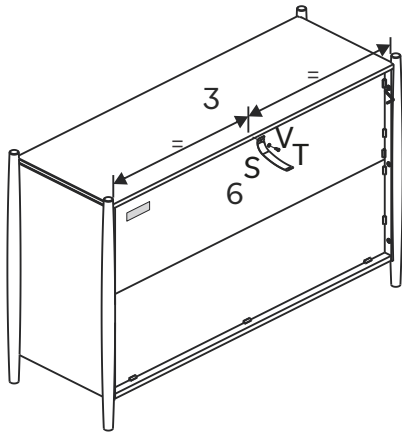

Étape / Paso 27

(FR)

Dernière étape ! Insérez la douille en plastique (U) dans le mur. Fixez ensuite l'ruban (S) au mur à l'aide de la rondelle (V) et de la vis (P).

(ES)

¡Último paso! Inserte el casquillo de plástico (U) en la pared. Luego, fije la cinta (S) a la pared con la arandela (V) y el tornillo (P).

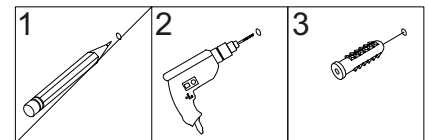
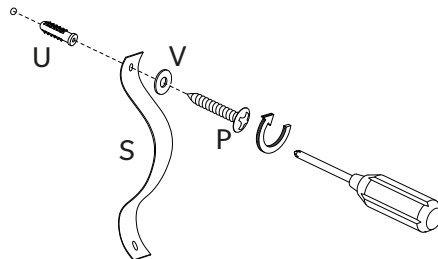

Avertissement

Des blessures graves, voire mortelles, peuvent survenir en cas de renversement de meubles. Pour éviter que le meuble ne bascule, nous recommandons de le xer définitivement au mur. L'ancrage mural et les autres composants sont inclus dans ce produit. Assure-toi que les composants sont adaptés à tes murs avant l'installation, car différents matériaux de mur peuvent nécessiter différents types d'ancrages.

Le nom et l'adresse du fabricant responsable des composants anti-basculer ainsi que la date de production se trouvent sur l'étiquette au dos du meuble.

Advertencia

Pueden ocurrir lesiones graves o fatales debido a la caída de muebles. Para evitar que los muebles se caigan, recomendamos que se jenen permanentemente a la pared. El anclaje de pared y los herrajes están incluidos en este producto. Asegúrate de que los herrajes sean adecuados para tus paredes antes de la instalación, ya que diferentes materiales de pared pueden requerir diferentes tipos de anclajes.

El nombre y la dirección del fabricante responsable de los herrajes antivuelco y la fecha de producción se pueden encontrar en la etiqueta de la parte trasera de los muebles.

À démonter / Para desmontar

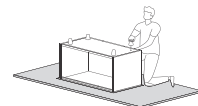

(FR)

S'il est nécessaire de démonter, retirez le Dovetail Lock (B) à l'aide d'un tournevis à tête plate.

(ES)

Si es necesario desmontarlo, retire el Dovetail Lock (B) con un destornillador de cabeza ranurada.

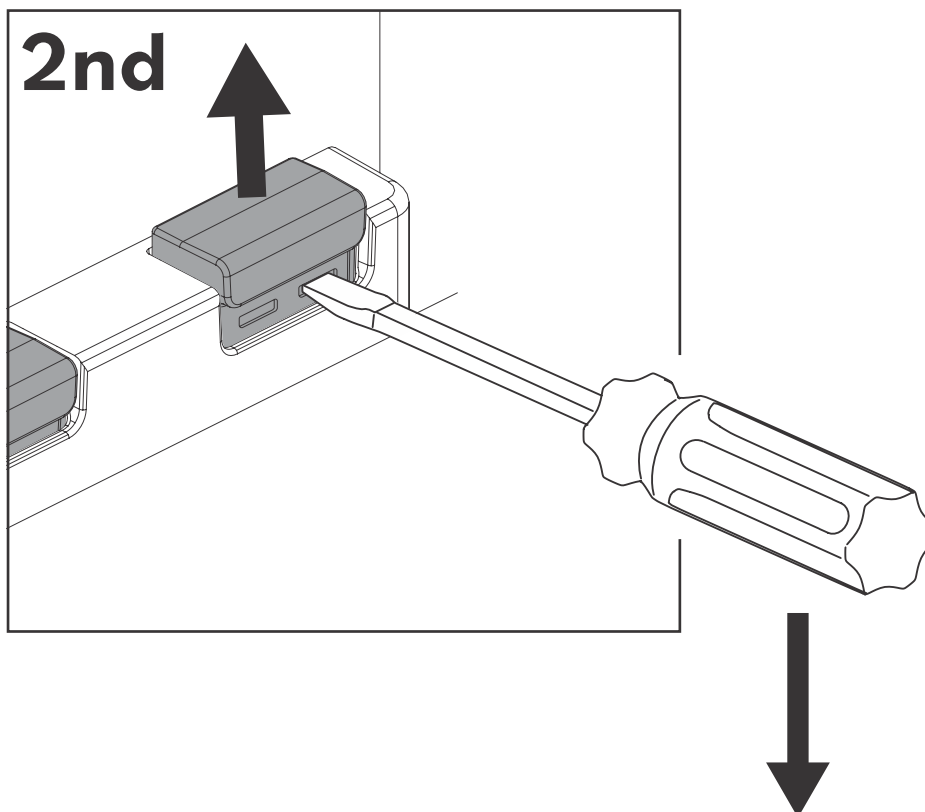
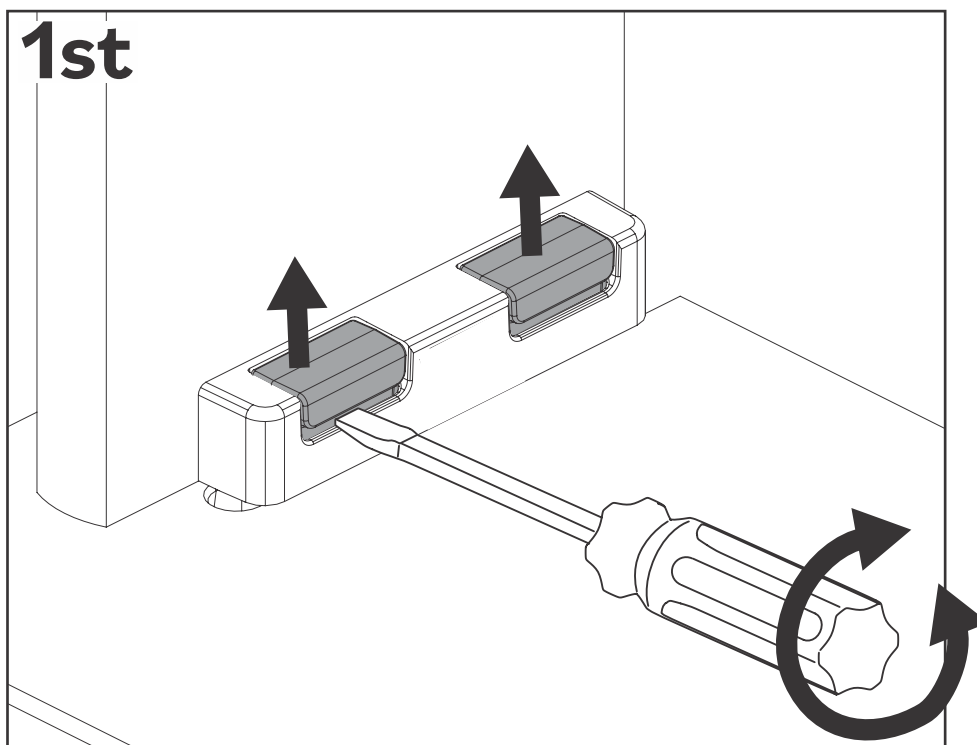

Tu as réussi ! Profite bien de ta nouvelle commode !
¡Lo lograste! ¡Disfruta de tu nueva cómoda!

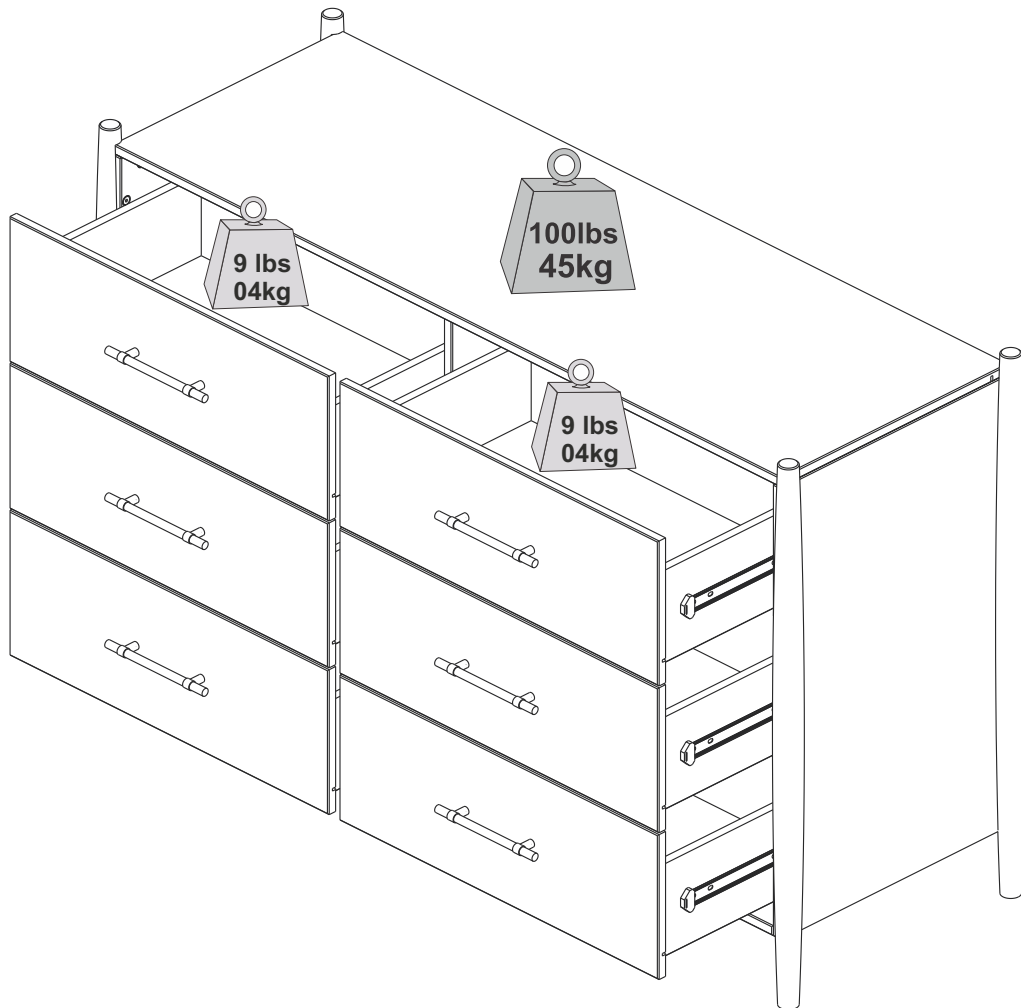

Bravo pour ton nouveau meuble !

Nous aimerions t'en entendre parler et le voir.

¡Enhorabuena por sus nuevos muebles!

Nos encantaría oírlo y verlo.