

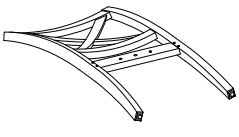

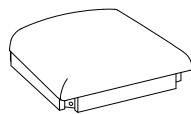

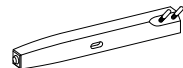

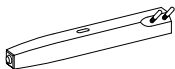
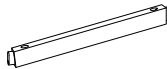

Assembly instructions for

963-250 Side Chair

Caution: Please read instructions thoroughly before unpacking assembly parts. Sharp, exposed staple tips can cause injury, therefore, for your protection, please remove any exposed staples used in packing.

1. We recommend that you should assemble this product with the assistance of another person; this will make assembly easier, and will help to eliminate damage to the product or injury to persons during assembly.
2. Be sure to check all packing materials carefully for small parts that may have come loose inside the carton during shipment.
3. Please do not over tighten screws or bolts.
4. Please put all parts on a non-abrasive floor before assembly, and follow the assembly steps to assemble your newly purchased product correctly and efficiently.

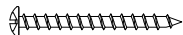
PARTS LIST	 (A)	 (B)	 (C)
SIDE CHAIR	Chair back: 1pc	Cushion seat: 1pc	Left leg: 1pc
PARTS LIST	 (D)	 (E)	 (F)
SIDE CHAIR	Right leg: 1pc	Left stripes: 1pc	Right stripes: 1pc

NO.	HARDWARE LIST (963-250)		Q'TY
1		(M6*38) SHORT BOLT	2+1pieces
2		(M6*75) LONG BOLT	4+1pieces
3		(Ø5/16*12MM) HEX NUT	4+1 pieces
4		(Ø5/16*13*1.2MM) SPRING WASHER	10+1 pieces
5		(Ø5/16*19*1.8MM) FLAT WASHER	10+1 pieces
6		(#8*45MM) WOOD SCREW	4+1 pieces
7		(L57*4MM) ALLEN KEY	1 piece
8		(Ø5/16*12MM) WRENCH	1 piece

Assembly instructions for 963-250 Side Chair

Step 1 : Unpack carton and place all parts on a non-abrasive floor.

Step 2 : Remove plastic cover from upholstered seat cushion (B)

Step 3 : Attach front leg (C,D) to Upholstered seat frame (B) by using flat washer (5), spring washer (4), hex nut (3), and secure by wrench (8).

Step 3

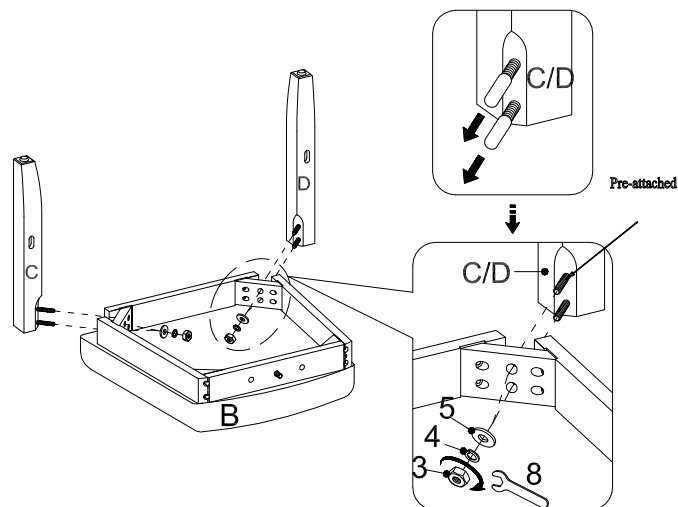

Step 4 : Attach the chair back frame (A) to the Upholstered seat frame (B) by using flat washers (5), spring washers (4) and short bolts (1) through the pre-drilled holes at the back rail of the wood seat frame into the insert nuts at the center of the chair back frame. Do not tighten all bolts until the seat is fully assembled.

Attach the chair back frame (A) to the Upholstered seat frame (B) by using flat washers (5), spring washers (4) and long bolts (2) through the pre-drilled holes in the rear corner blocks of the wood seat frame and into the insert nuts on the legs of the chair back frame (A). Use hand to tighten bolts. Don't use Allen Key (7) to tighten the bolts tightly yet.

Step 4

The cushion will face up when the unit is turned upright.

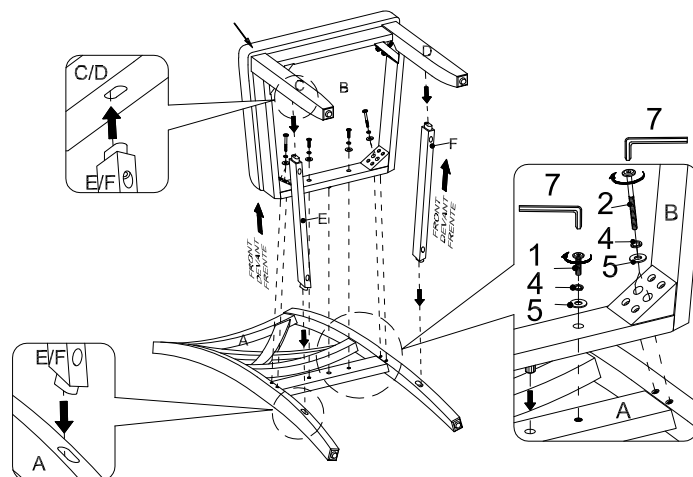

Step 5 : Attach the chair stripes(E,F) (please note it is separated Left and Right stripes) to the Back Chair (A) and Front Legs(C,D) using wood screws (6) to secure tightly.

Most floors have slight irregularities that can effect chair leveling. If your chair is uneven when placed in its desired location , please perform the following steps:

1. Loosen all bolts.
2. Put the chairs at the desired location.
3. Gently push downward on the front of seat and also at the back edge of seat until all four legs rest on floor.
4. Once the chair is level, no wobbly issue, now use Allen key to tighten all bolts securely again.

Step 5

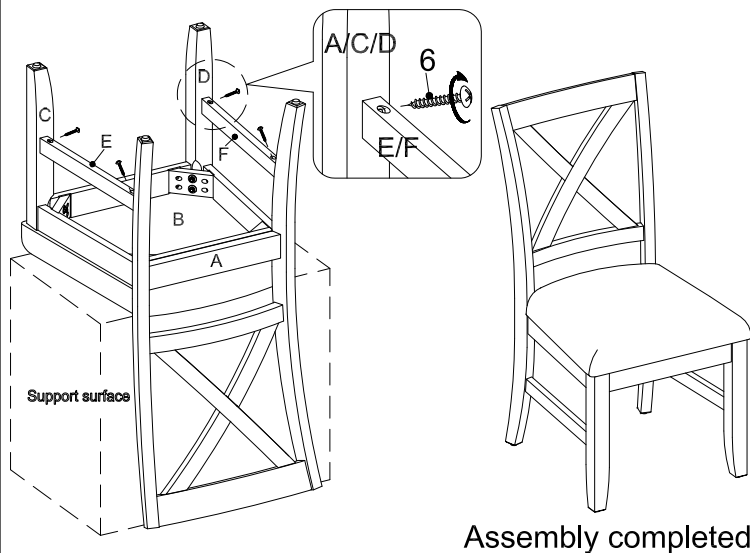

Assembly completed