

Night Stand with Shelf

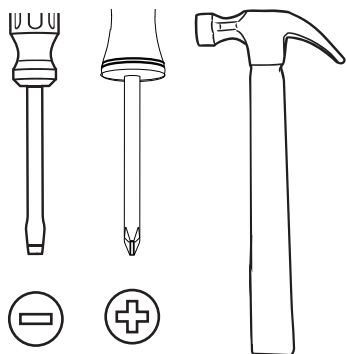

Tools

Vous aurez besoin / Necesitarás



2 person recommended

2 personnes recommandées /

2 personas recomendadas

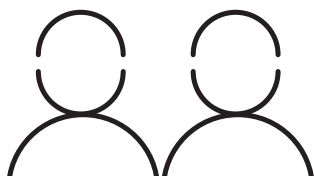

Parts

Pièces

Piezas

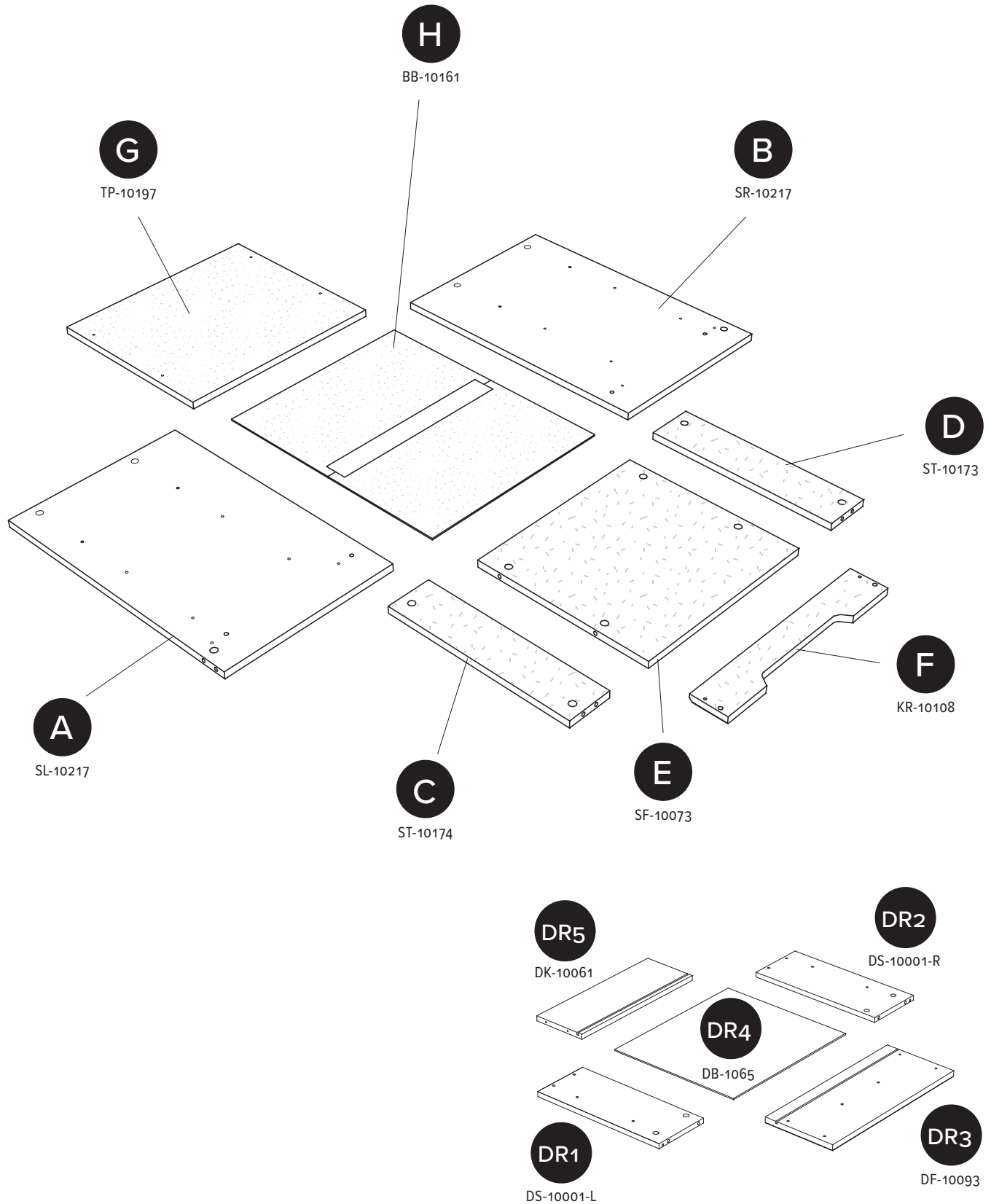

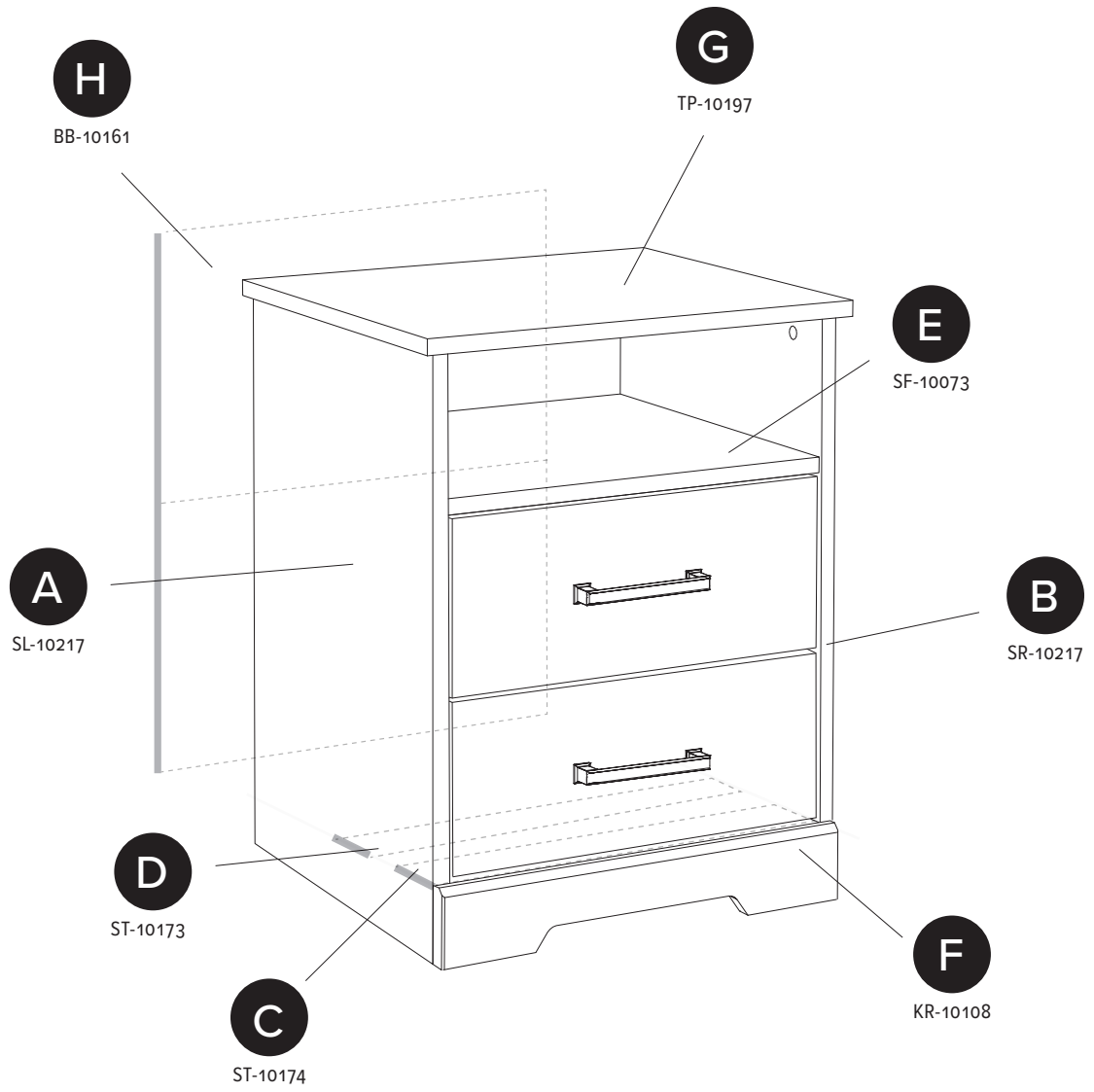

Hardware

Quincaillerie

Piezas de Conexión

14 X



RM-0103

14 X

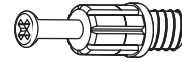

RM-0501

6 X

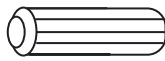

RM-0069

20 X



RM-0022

16 X



RM-0074

4 X



RM-0802

8 X



RM-0715

8 X



RM-0504

8 X

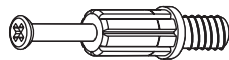

RM-0500

4 X

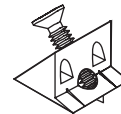

RM-0839

2 X

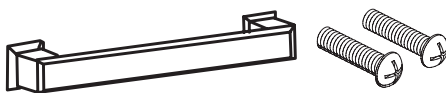

RM-0907-B

2X Drawer Slides Set (Blue Wheels)

Ensemble de glissières de tiroir (roues bleues)

Juego de guías para cajones (ruedas azules)

RM-0469-G

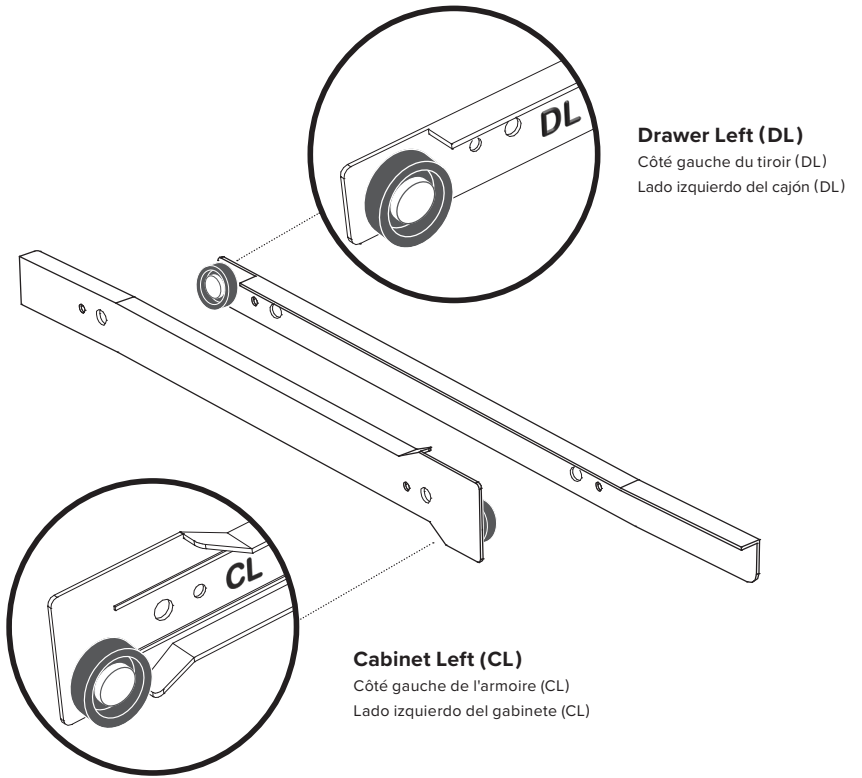

2X Drawer Slides Set (Red Wheels)

Ensemble de glissières de tiroir (roues rouges)

Juego de guías para cajones (ruedas rojas)

RM-0469-G

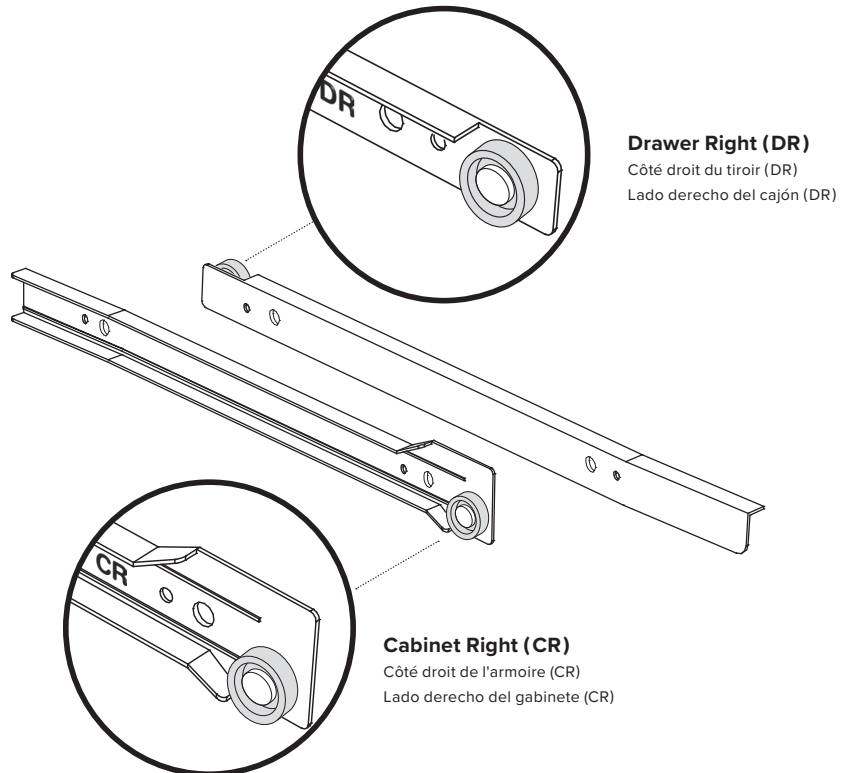

Assemble in 18 steps

Assemblage en 18 étapes

Montar en 18 pasos



35 mins

**Let's
start!**

Commençons!

¡Comencemos!

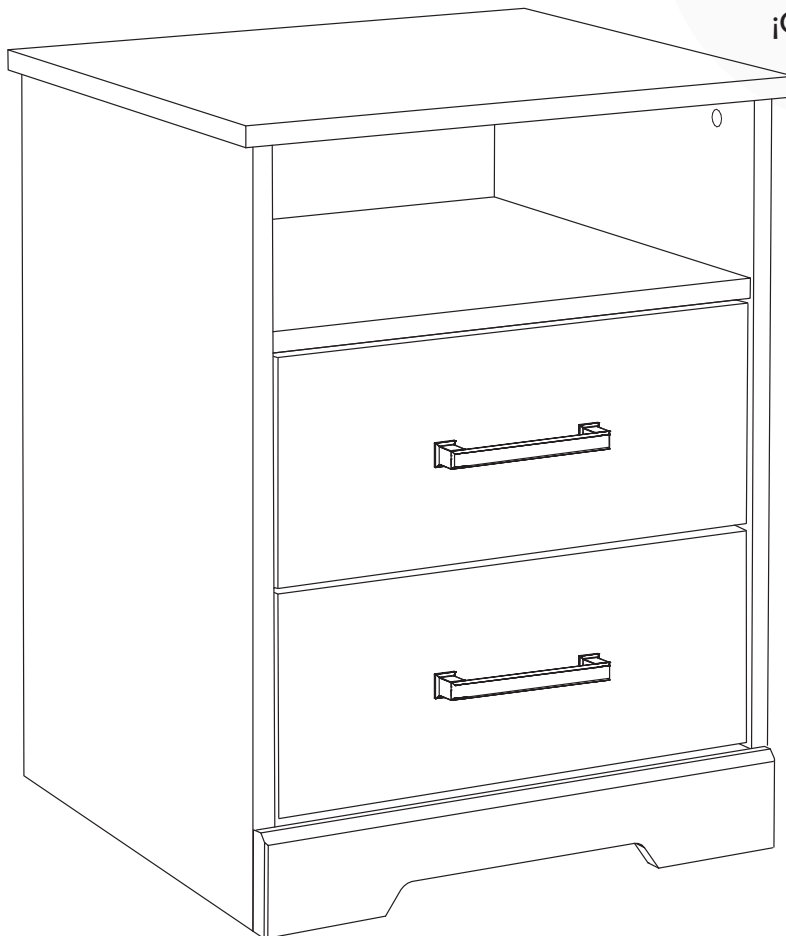

1



8X



RM-0074

2X

Blue Wheel Slider Cabinet Left (CL)

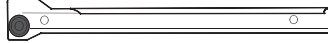

2X

Red Wheel Slider Cabinet Right (CR)

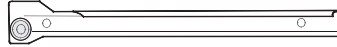

A

SL-10217

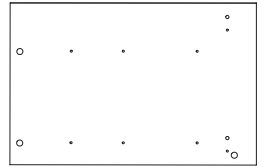

B

SR-10217

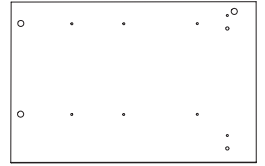

Blue Wheel Slider
Cabinet Left (CL)

Red Wheel Slider
Cabinet Right (CR)

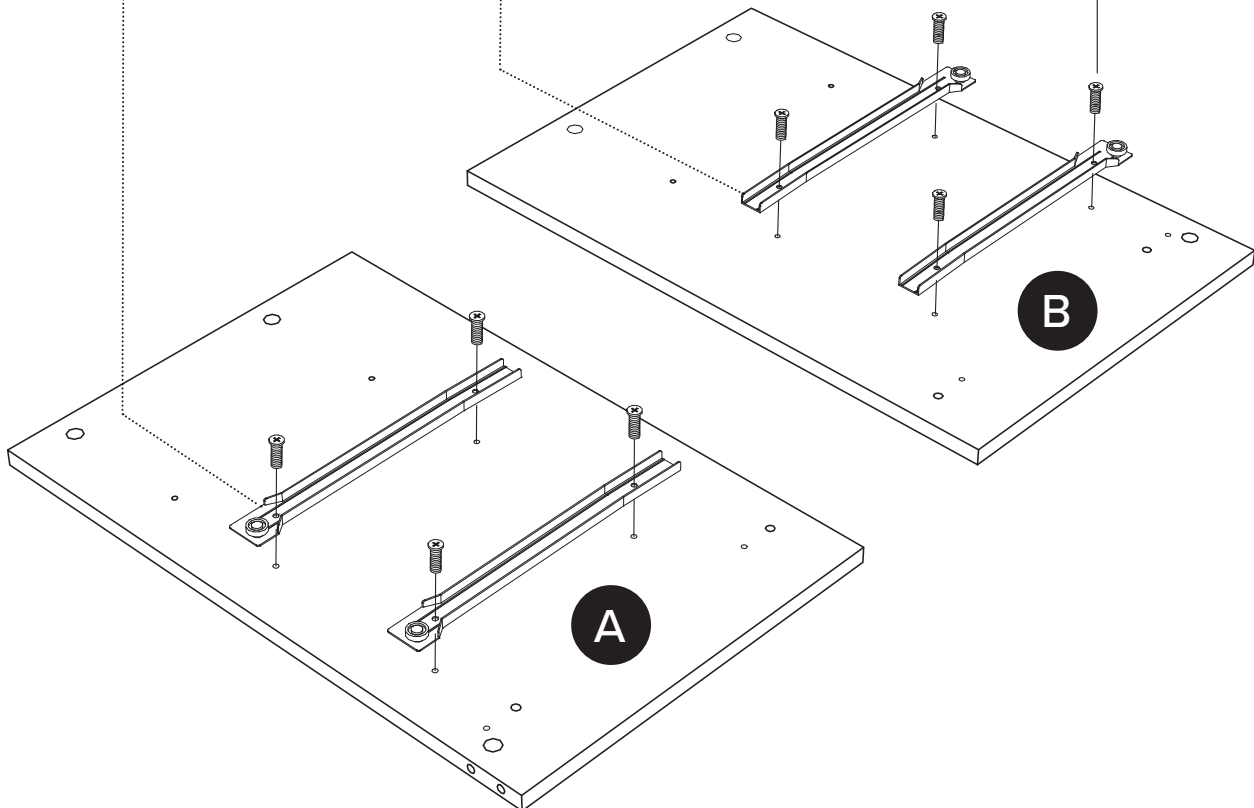
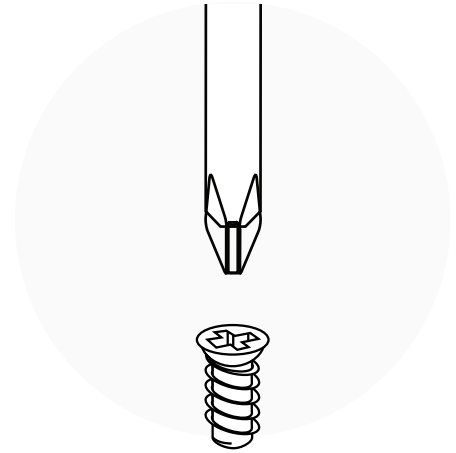
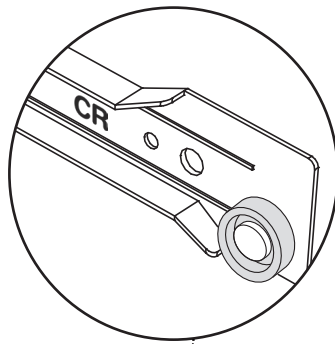
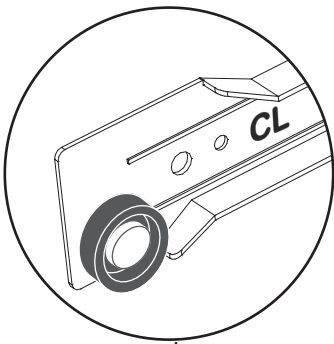

2



RM-0103

6X

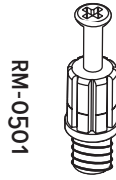

RM-0501

8X

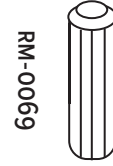

RM-0069

4X

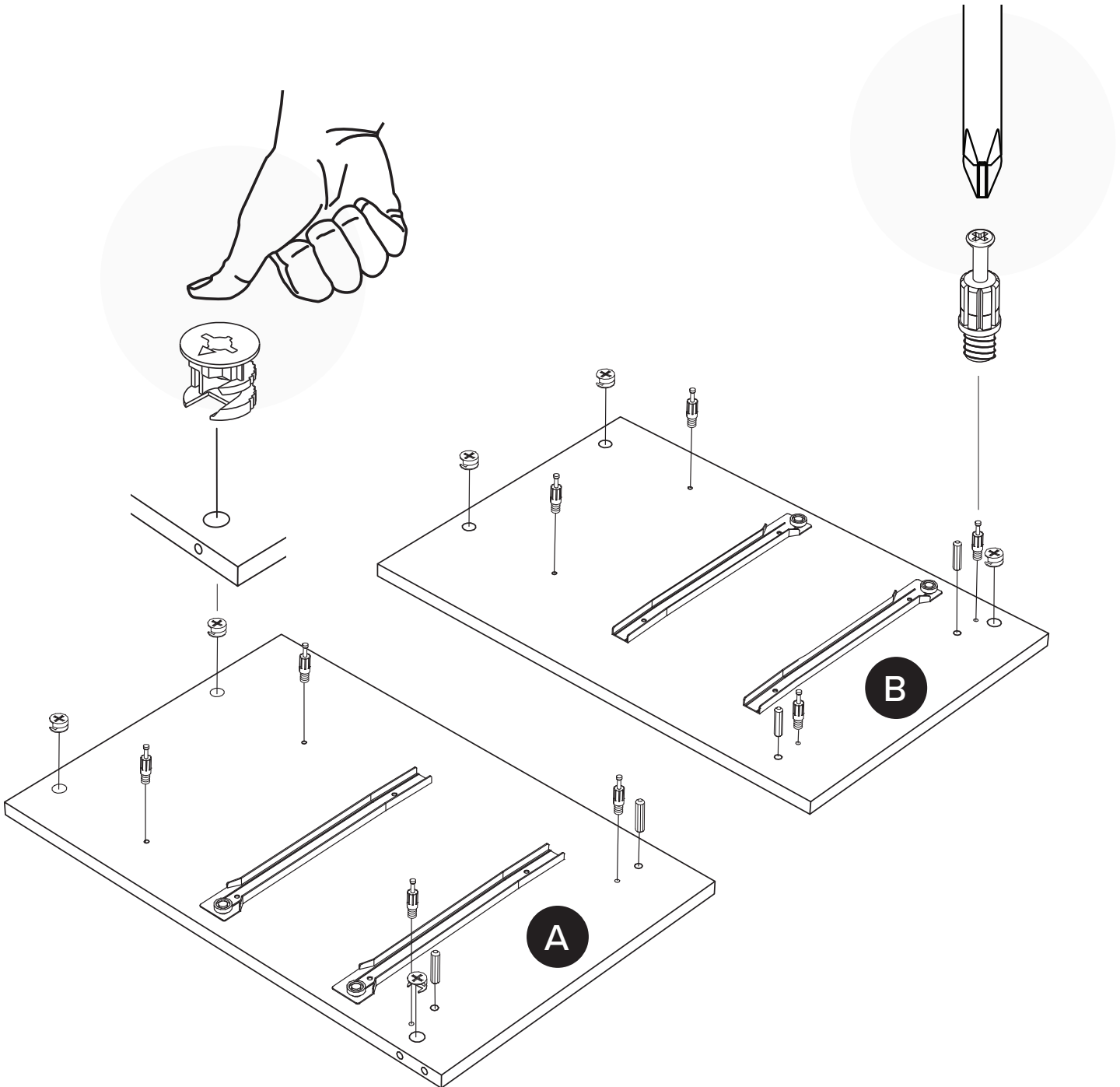

3



8X



ST-10174



SF-10073



ST-10173

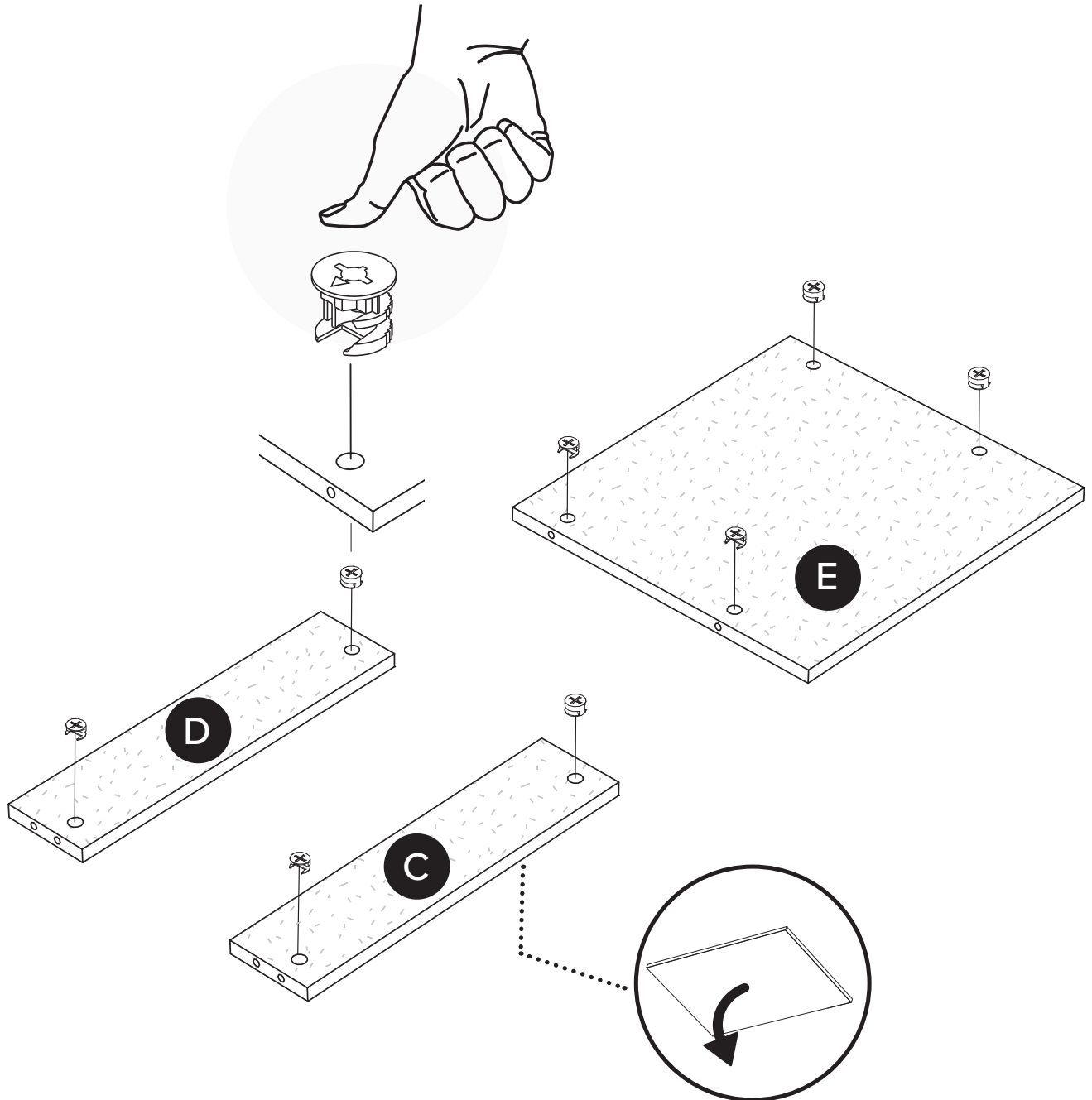
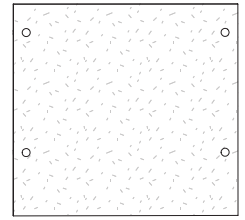

Paper finish facing down

Finition papier vers le bas

Acabado del papel hacia abajo

4

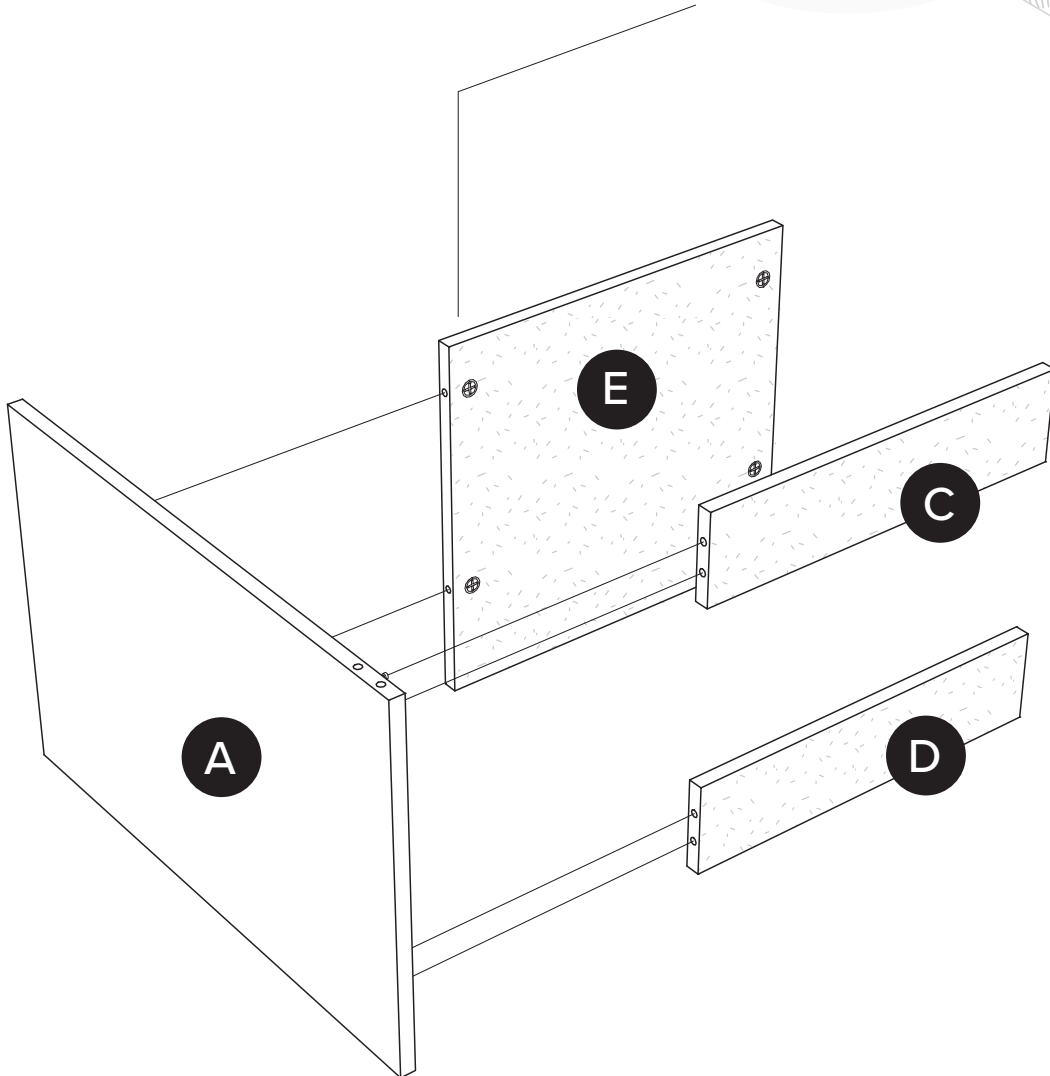
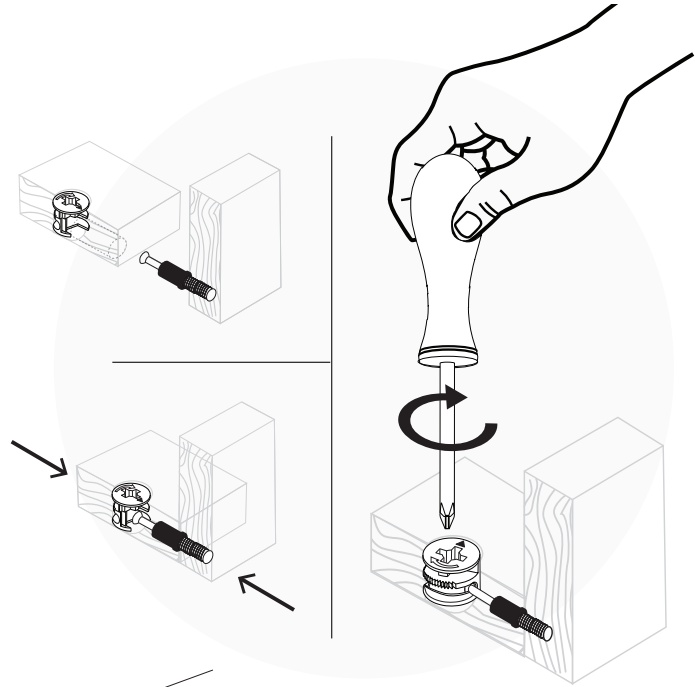

5

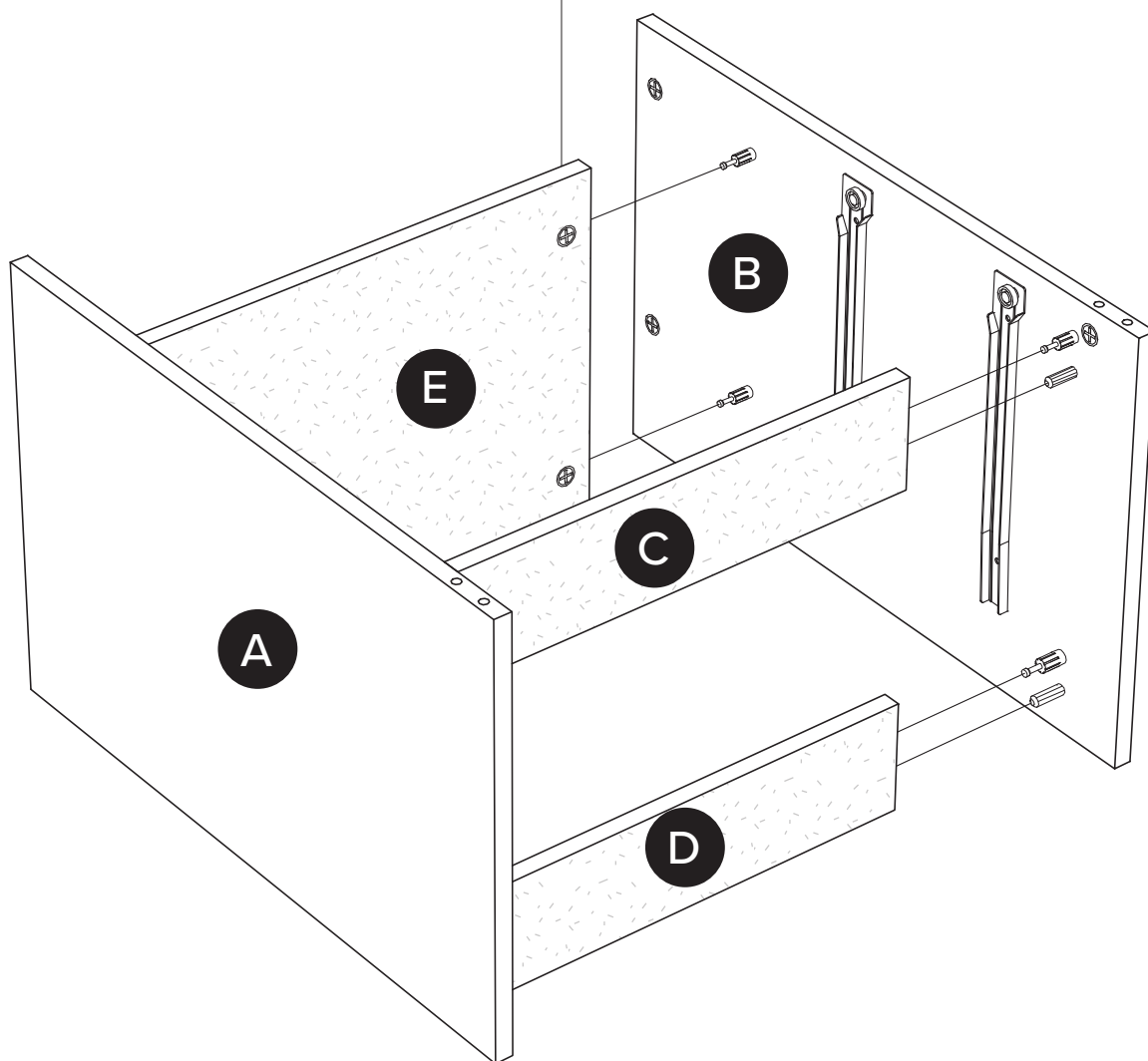
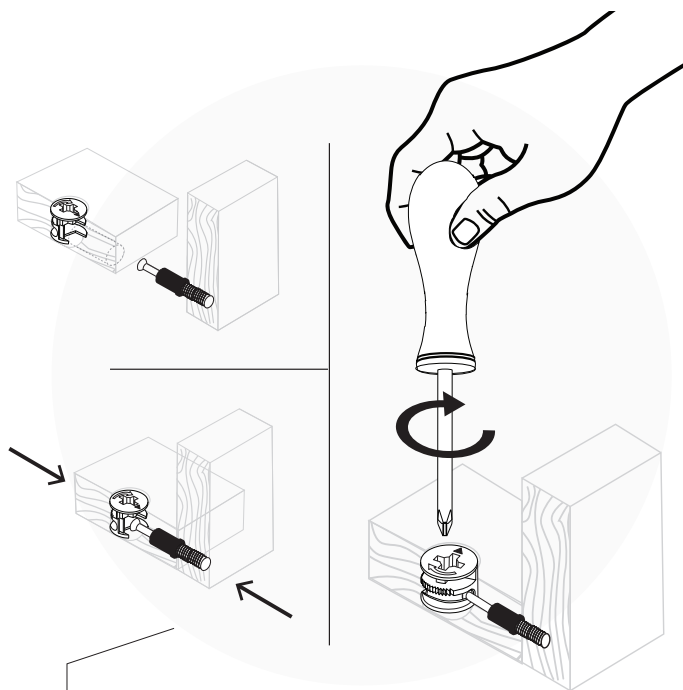

6



RM-0069



2X

RM-0501



2X

F

KR-10108

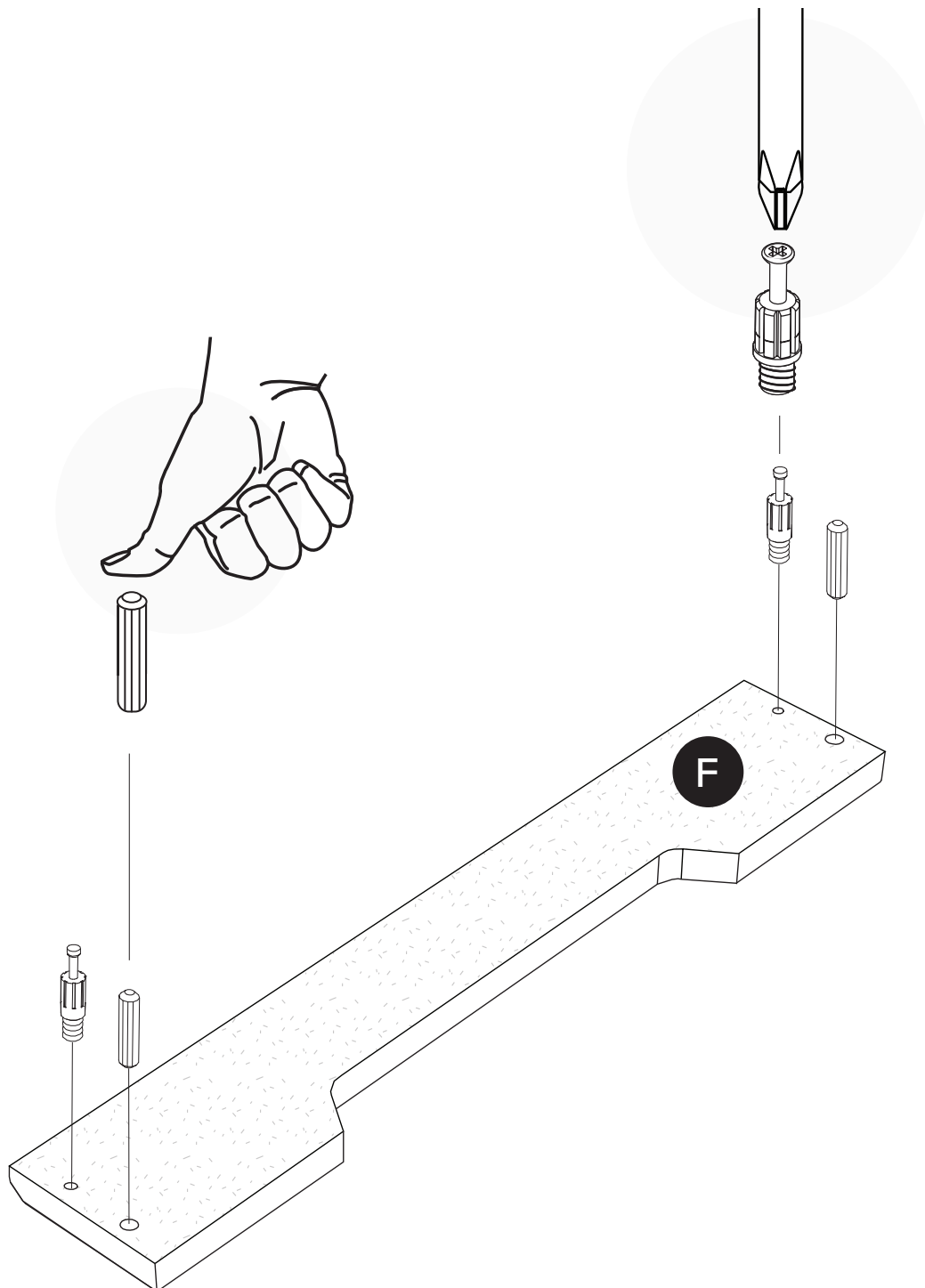

7

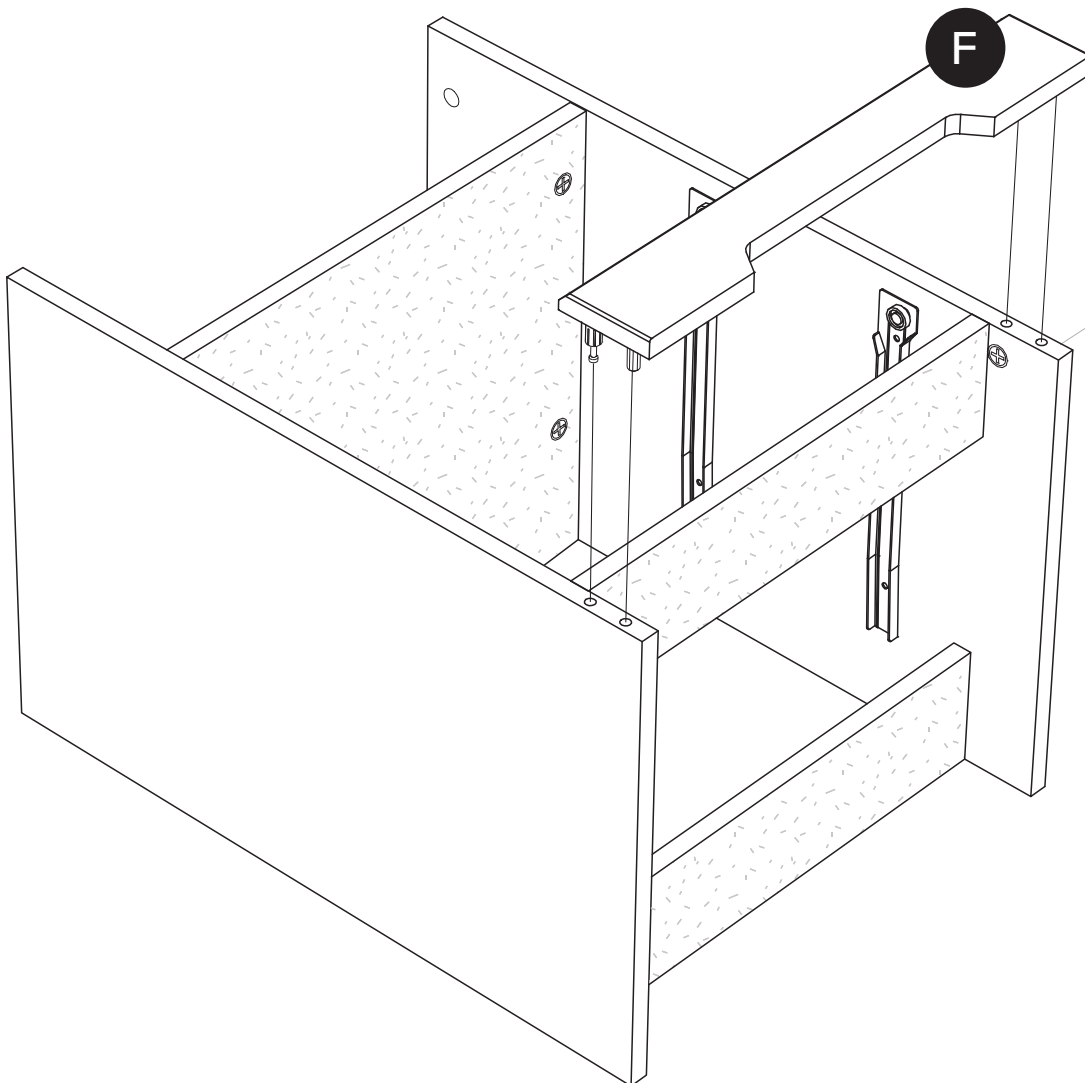
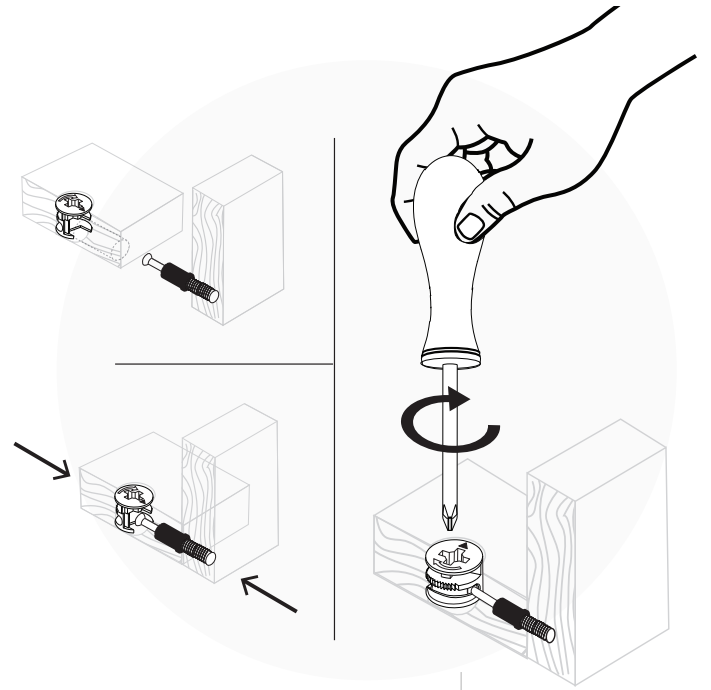

8



RM-0501



4X



TP-10197

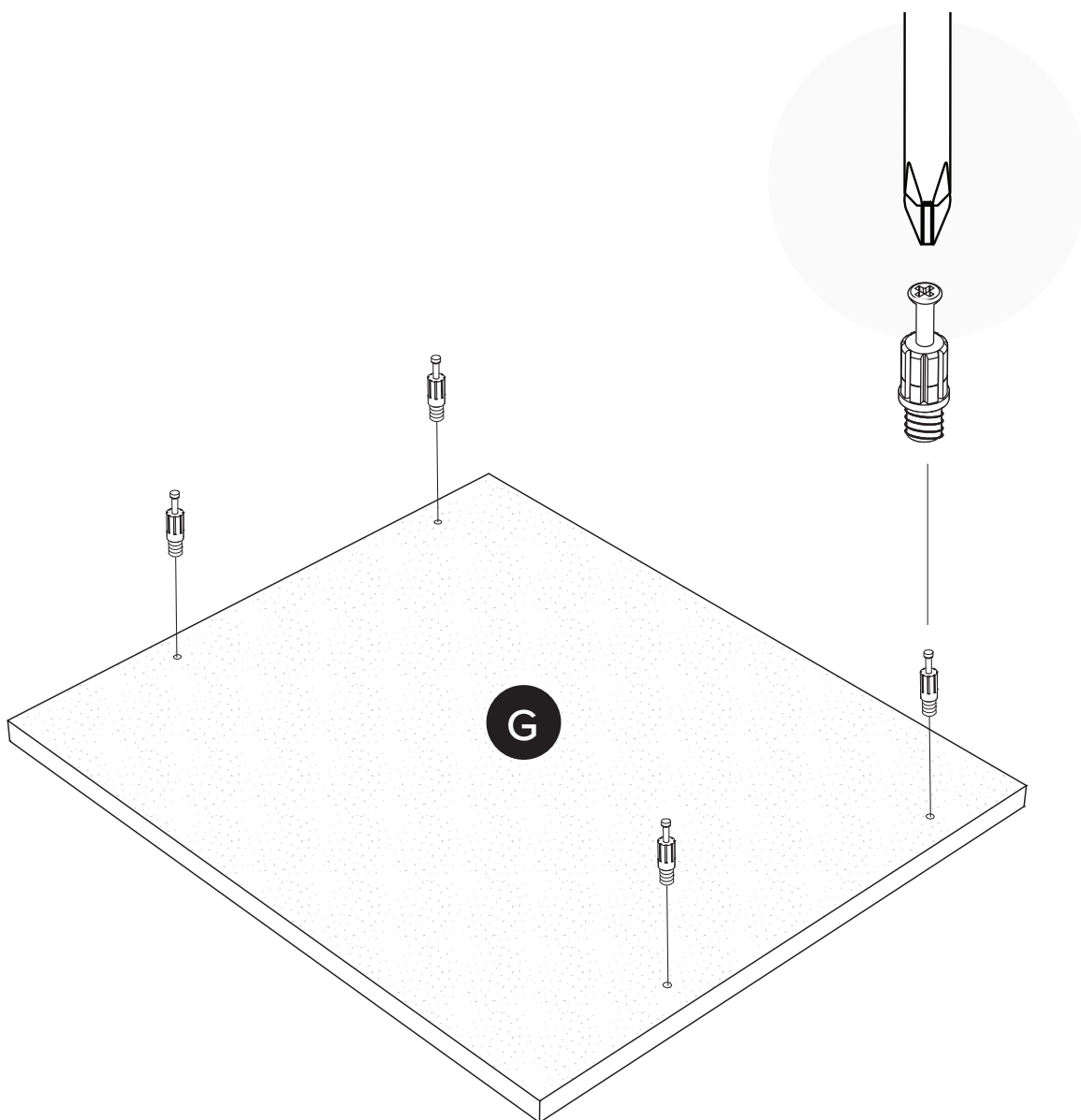
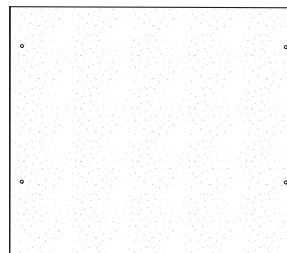

9



RM-0802-A



4X

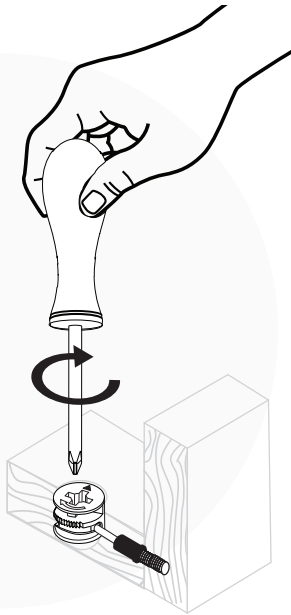
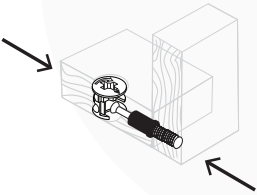
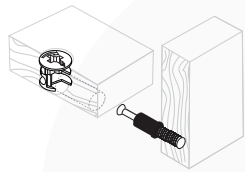
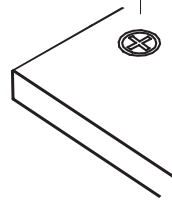
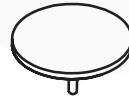

G

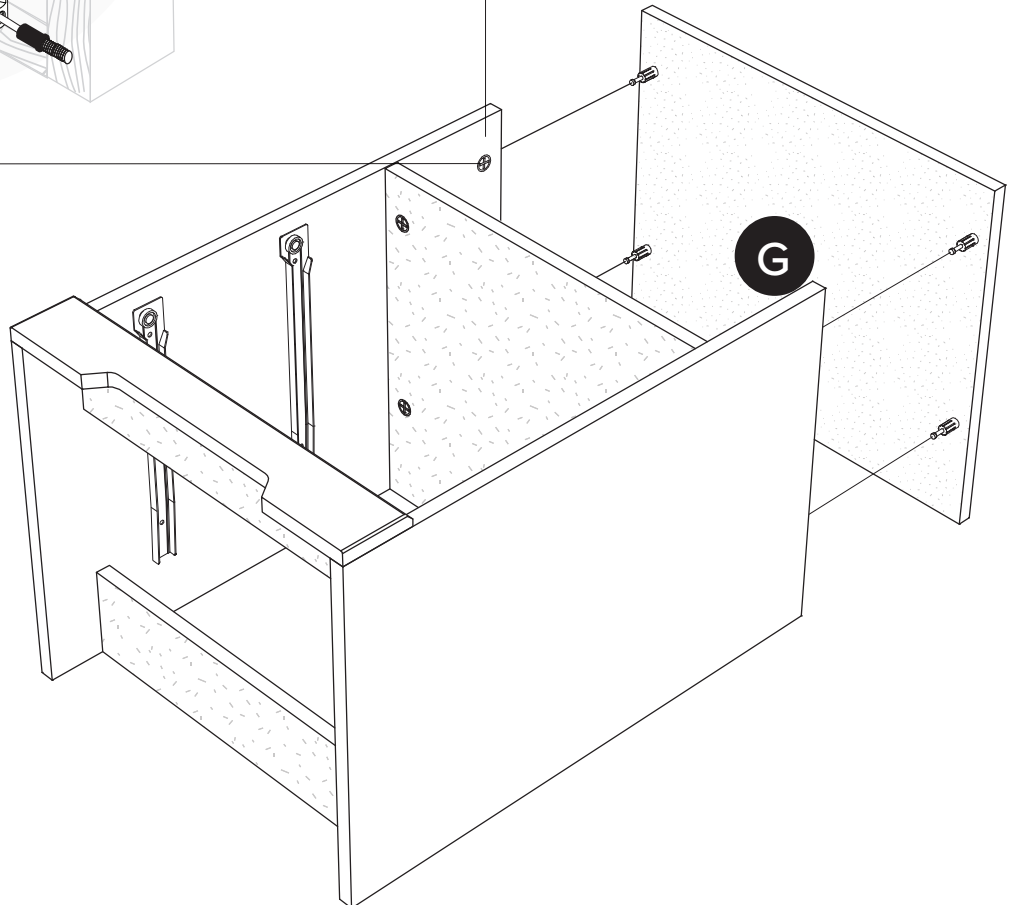

10



RM-0022
16 X

H
BB-10161

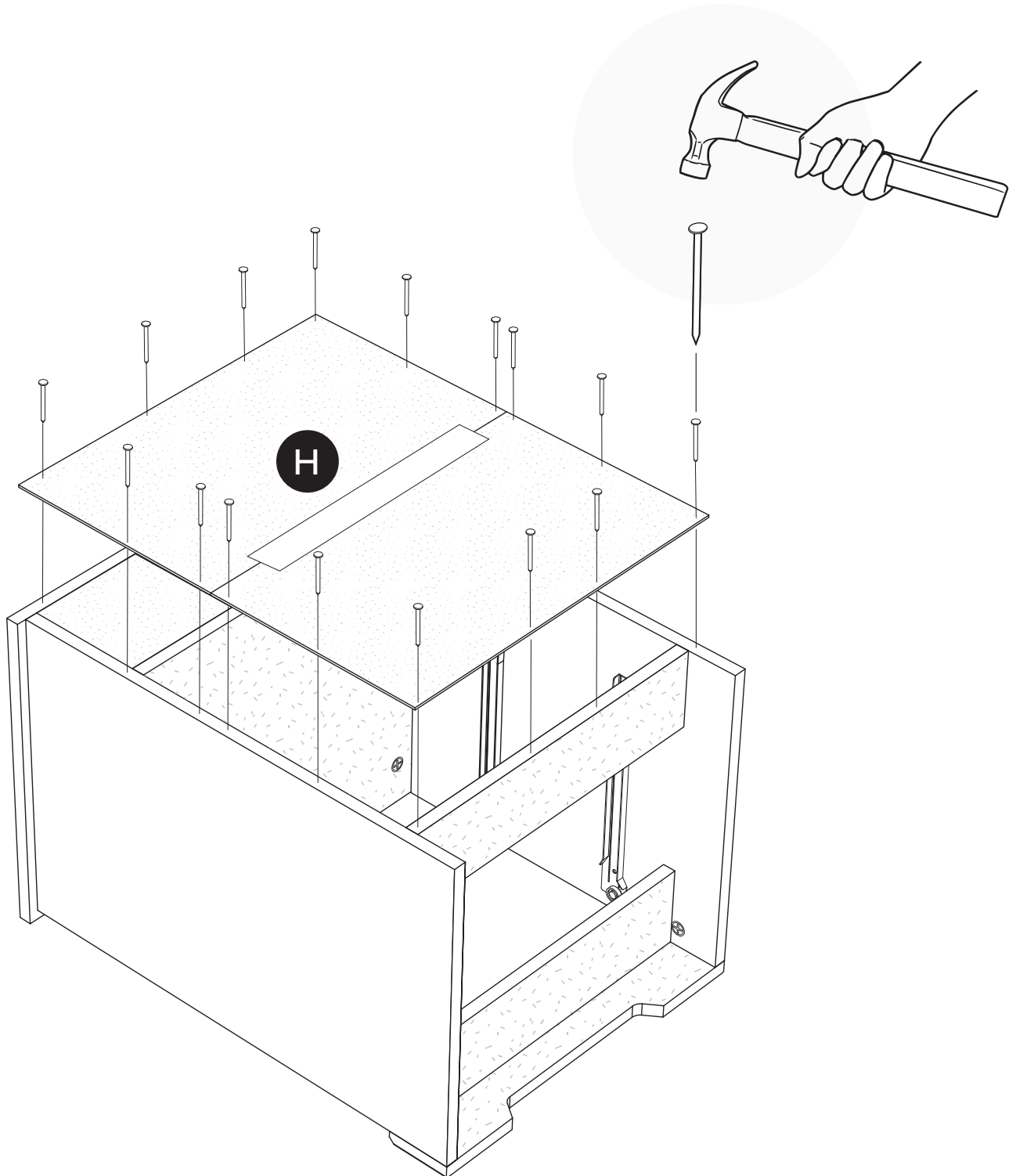
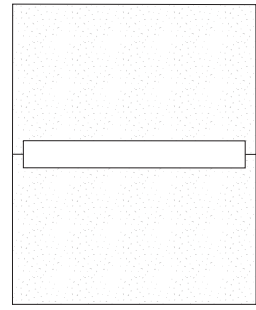

11

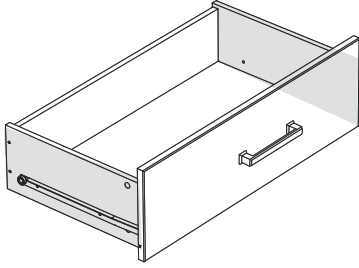

4X  RM-0074

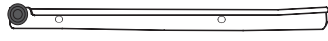
1X  Blue Wheel Slider (Drawer Side)

1X  Red Wheel Slider (Drawer Side)

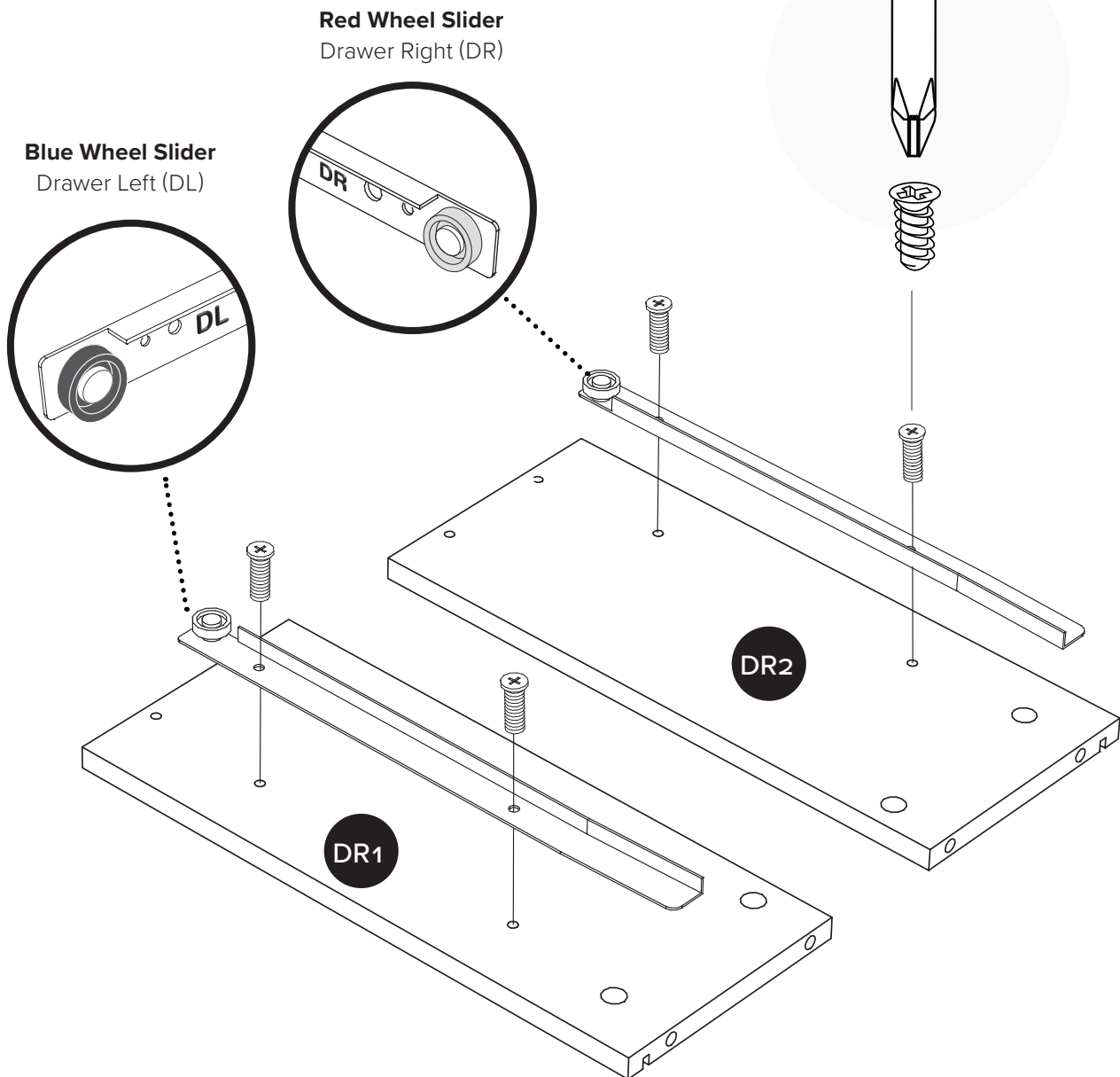
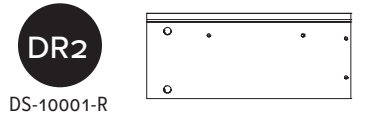
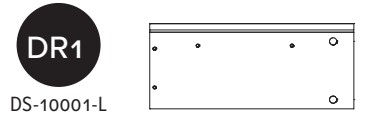

12

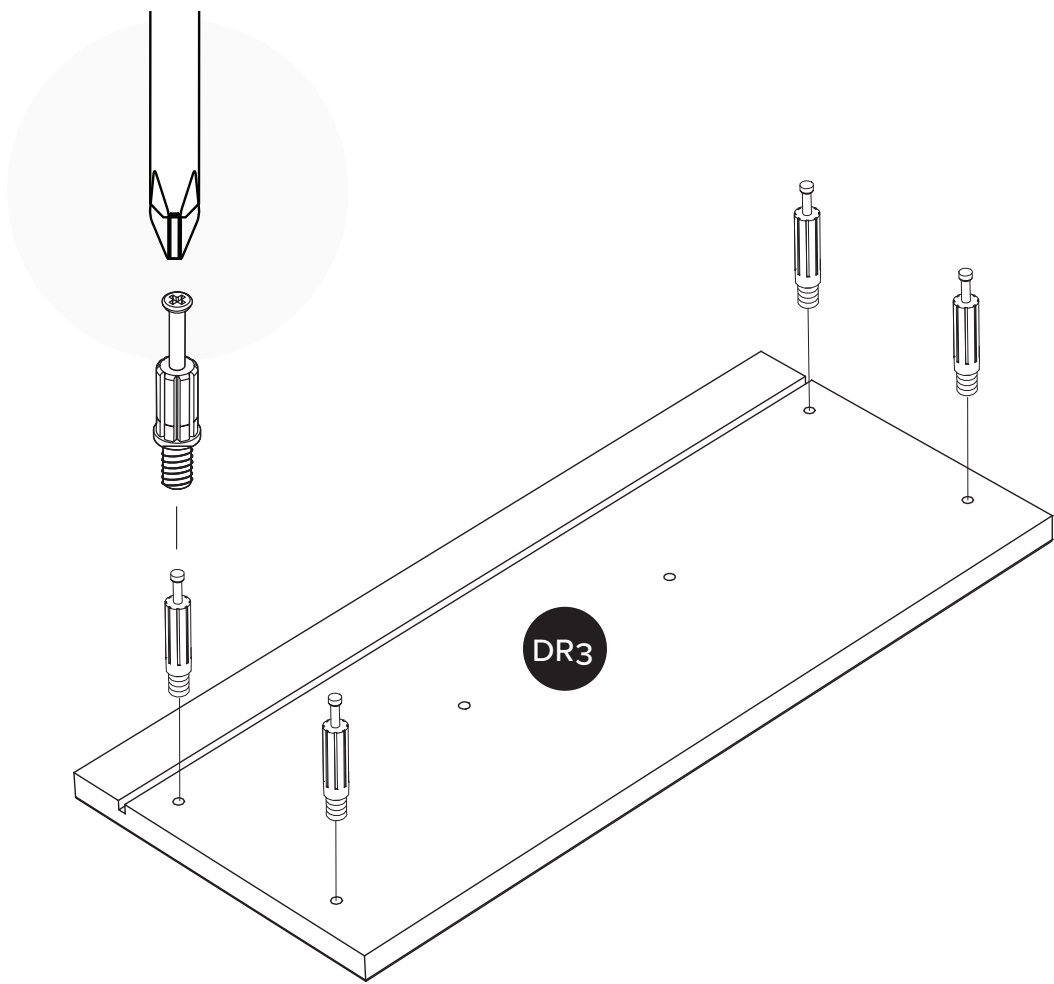
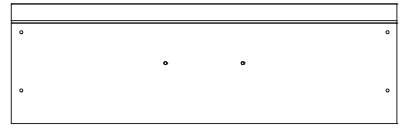
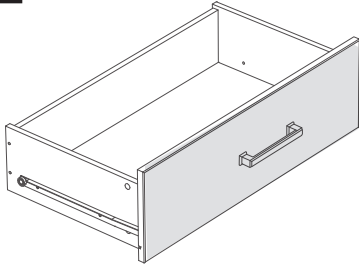

13

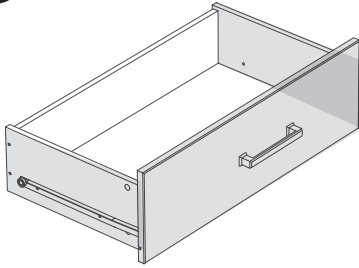

RM-0715



4X

DR3

DF-10093

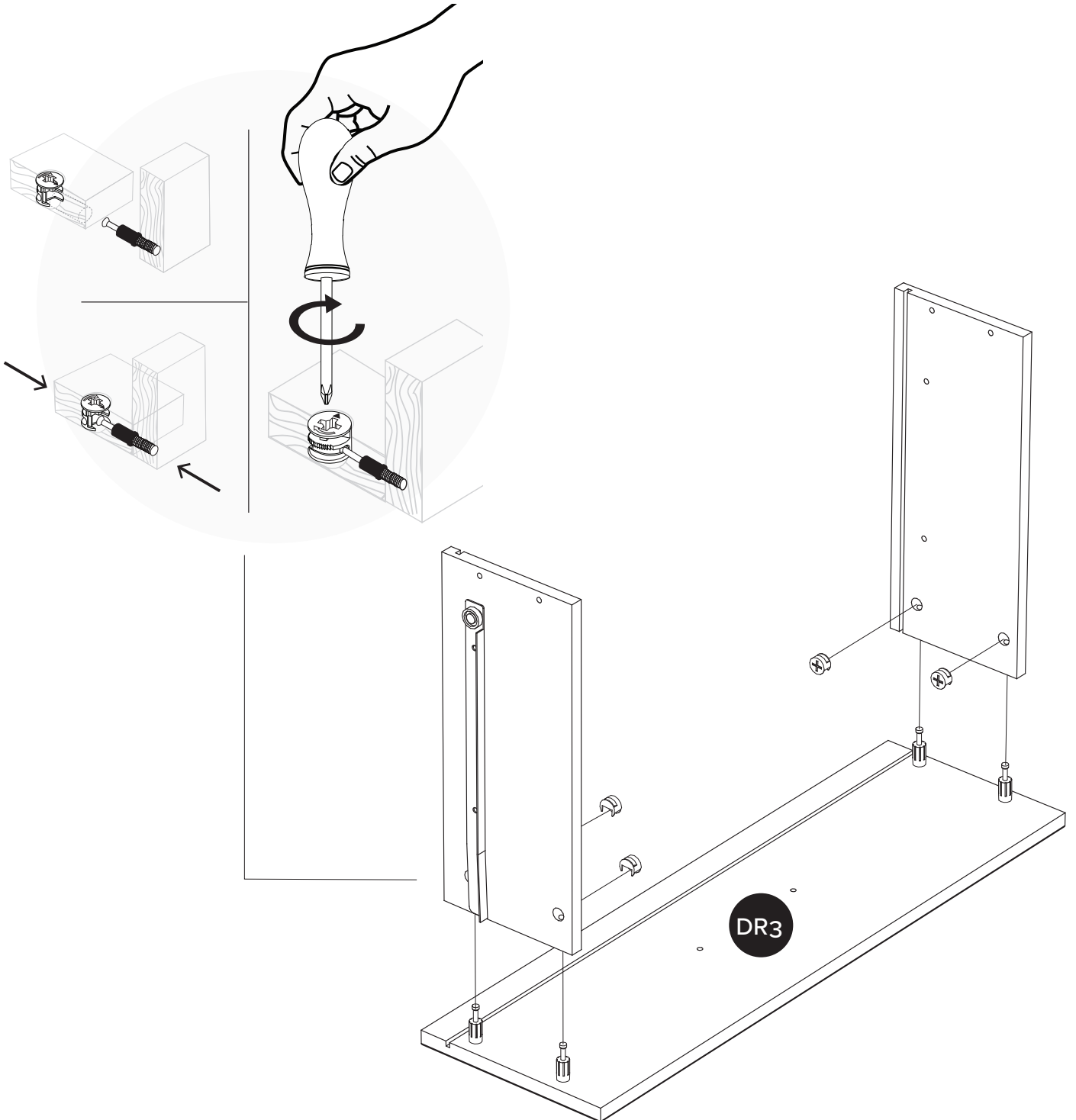
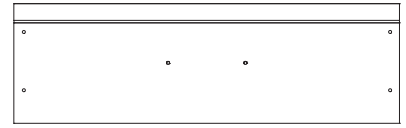

14

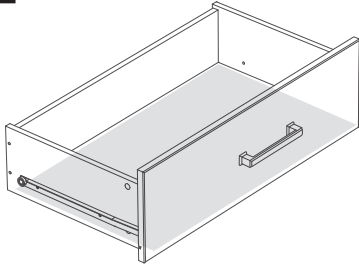

DR4
DB-10065

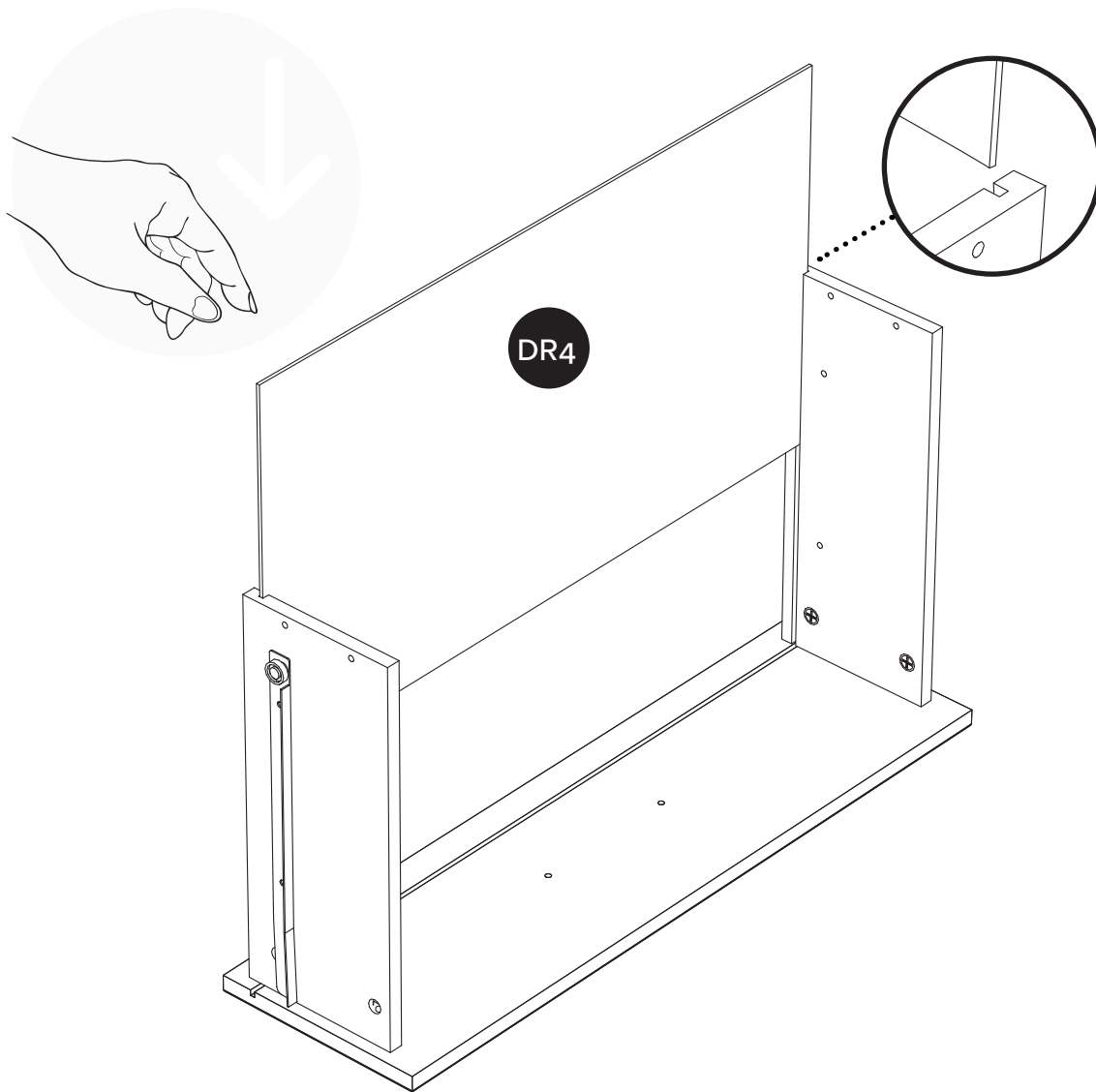
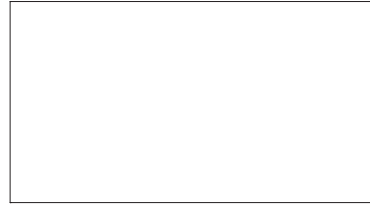

15

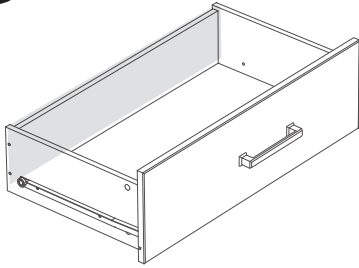

4X

DR5
DK-10061

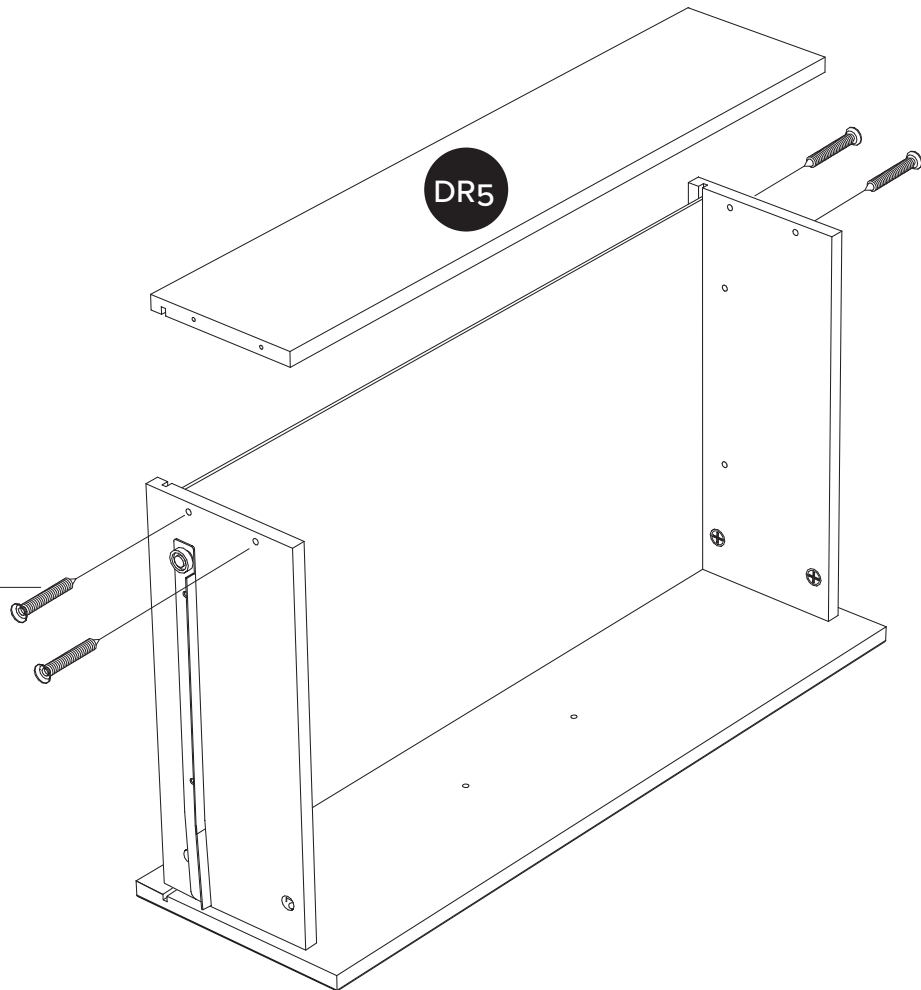
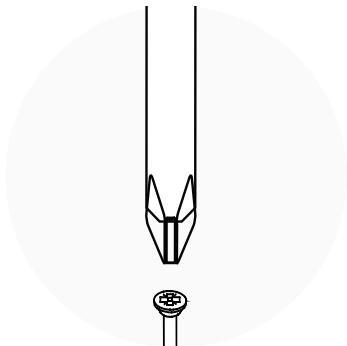

16

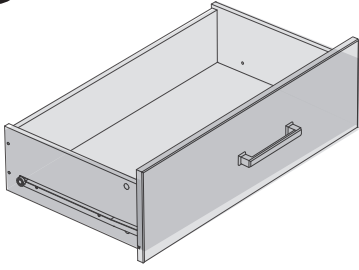

RM-0907-B

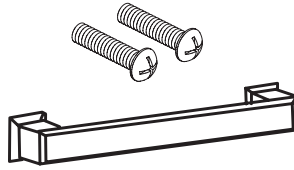

1X

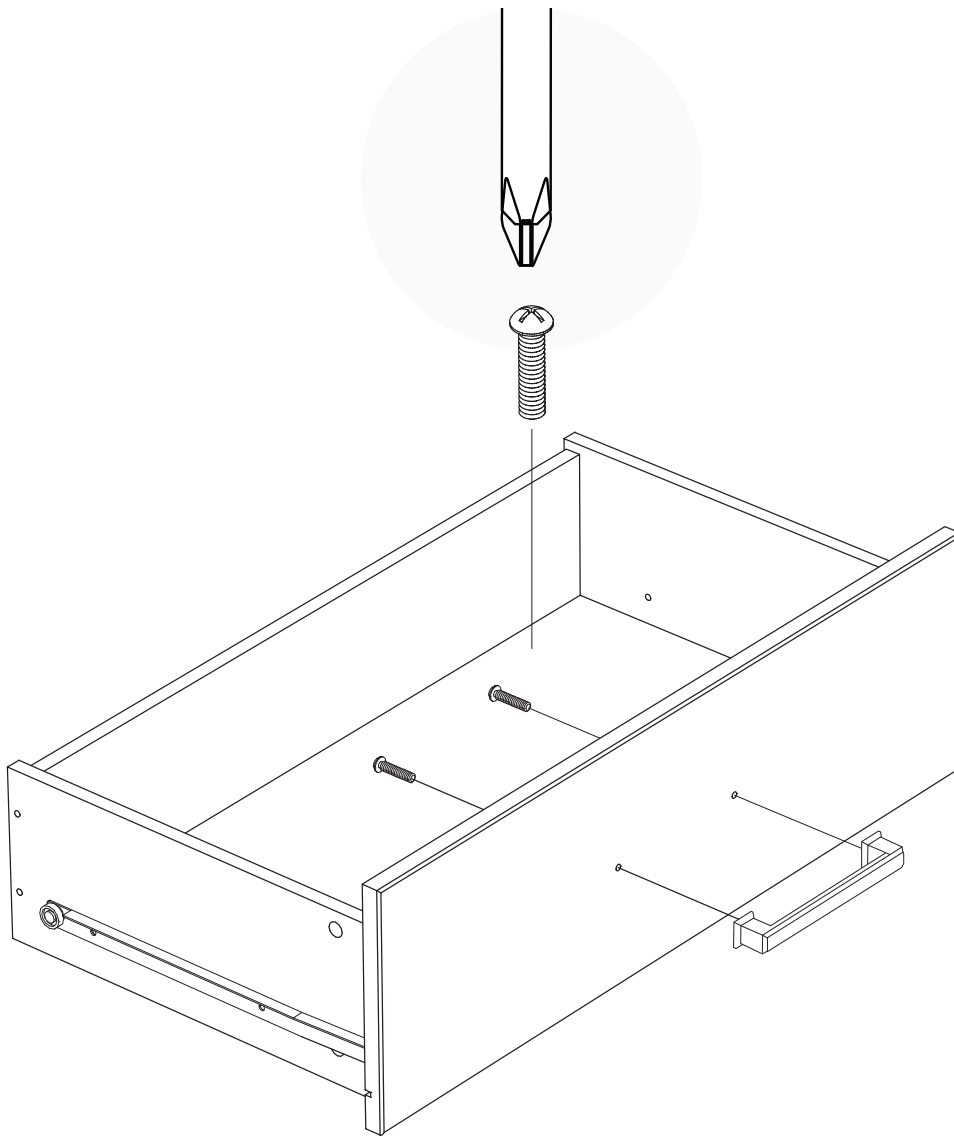

17

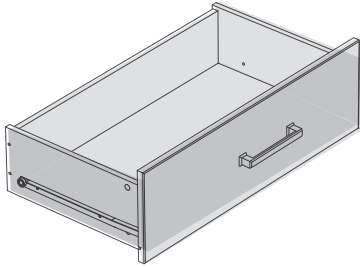

RM-0839

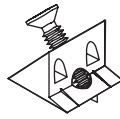

2X

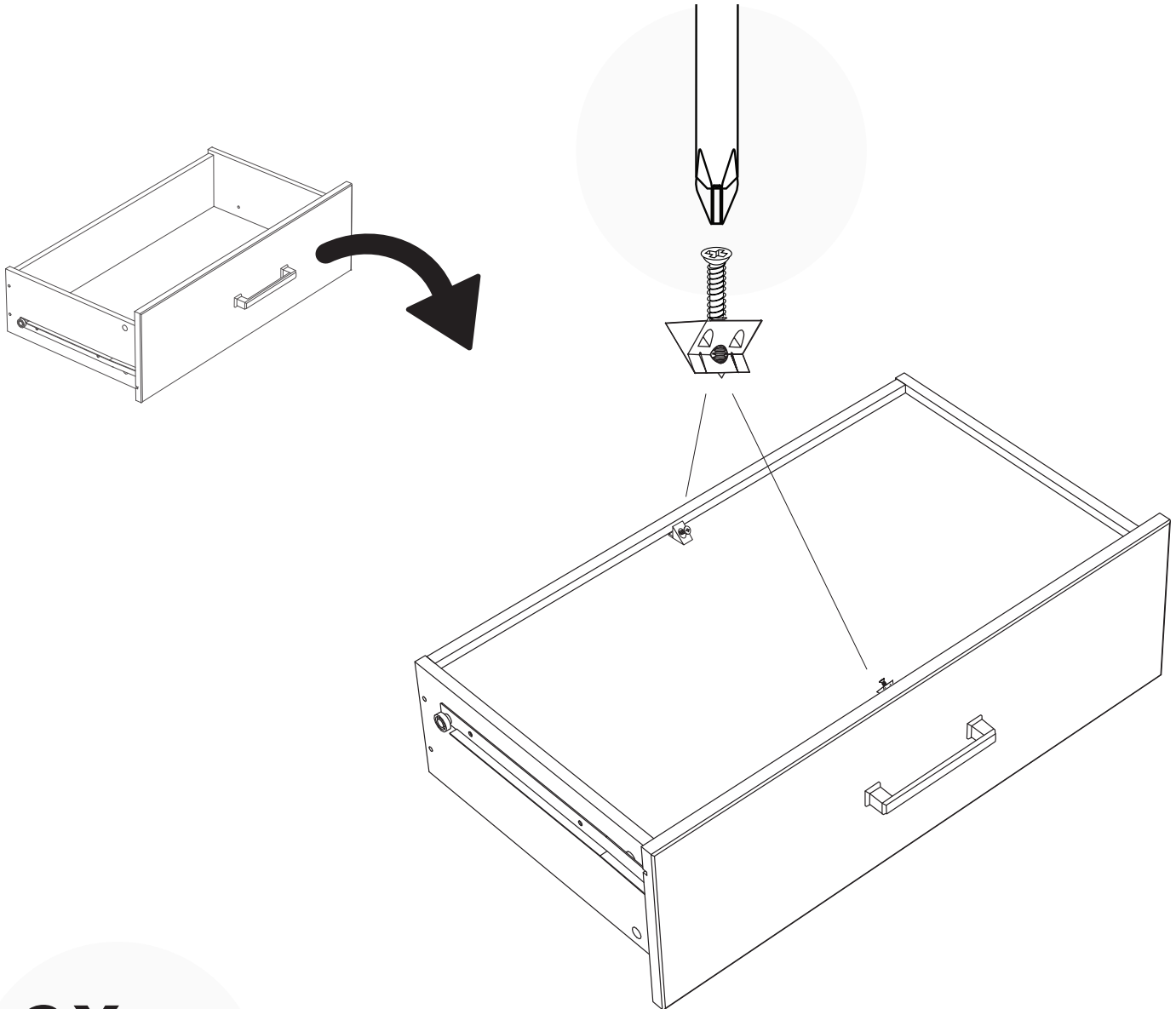

2X



Repeat step 11–17 for 2 drawers

Répétez l'étape 11–17 pour 2 tiroirs

Repita los pasos 11–17 para 2 cajones

18

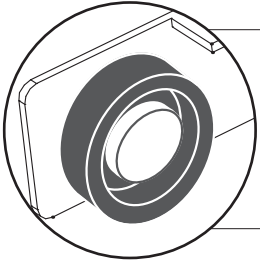

Blue Wheels for the left side

Roues bleues pour le côté gauche
Ruedas azules para el lado izquierdo

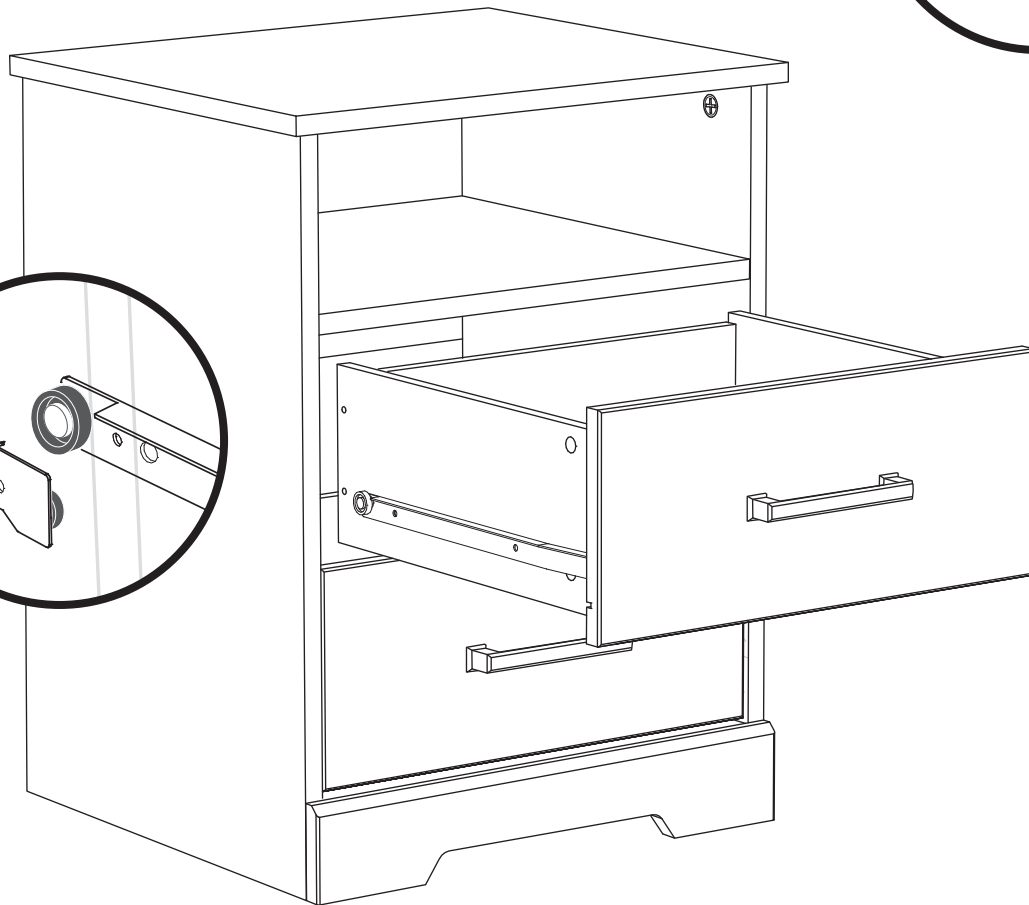
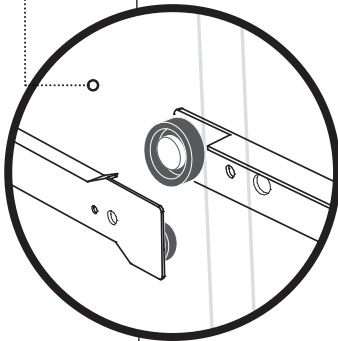
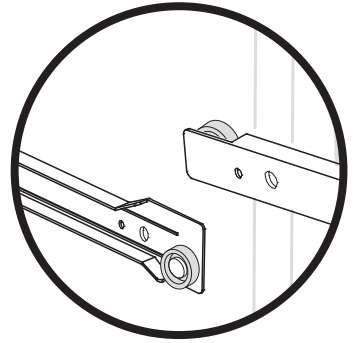

Red Wheels for the right side

Roues rouges pour le côté droit
Ruedas rojas para el lado derecho

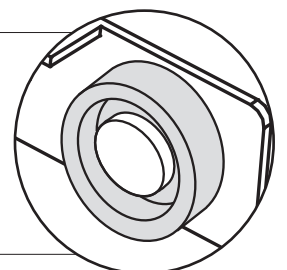

All done!
Good job!

Tout est fait! Bon travail!

¡Todo listo! ¡Buen trabajo!

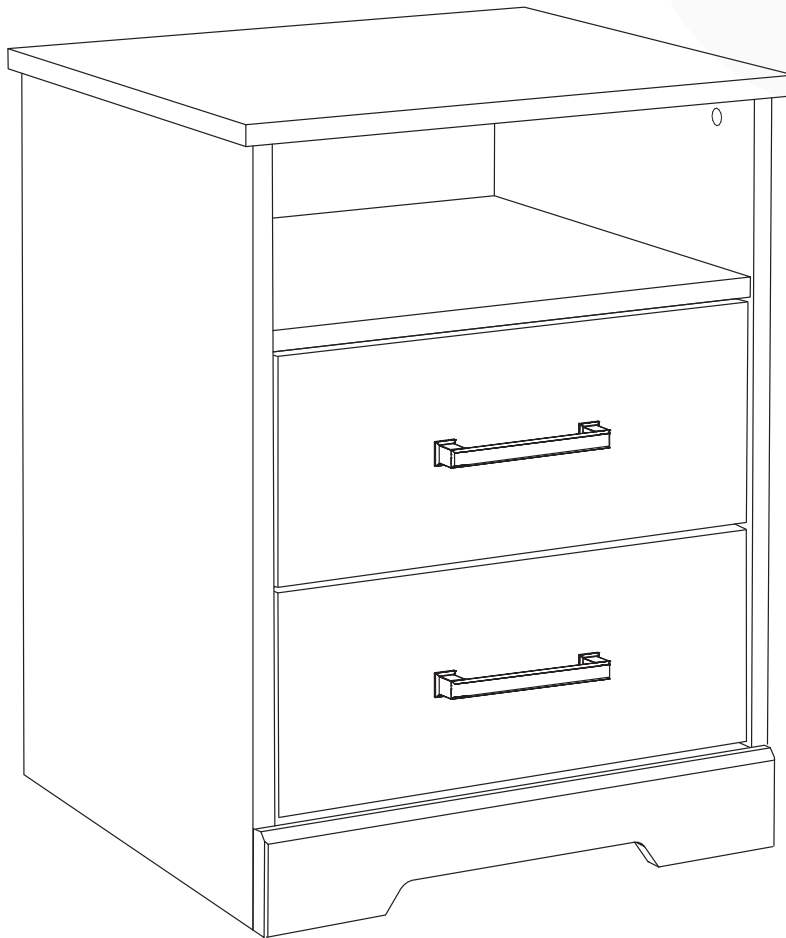

Tipover Restraint Device

Fixation du dispositif de retenue
Instalando la correa de seguridad

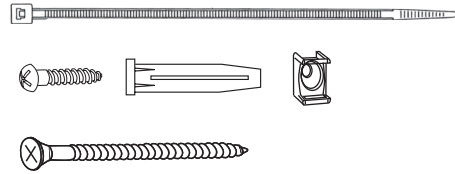

Safety Notice

Prepac recommends anchoring furniture in homes where children live or visit and has included an easy to install safety device. Please make sure that it is installed according to the following instructions.

Noticia de seguridad

Prepac recomienda anclar muebles en hogares donde viven niños o ellos visitan. Prepac ha incluido un dispositivo de seguridad de facil instalacion. Por favor seguresse de que esta instalado de acuerdo a las siguientes instrucciones.

Avis de sécurité

Prepac recommande l'ancrage des meubles dans les domiciles où habitent ou visitent des enfants, d'où l'inclusion d'un dispositif de sécurité facile à installer. Veuillez vous assurer que ce dernier est installé conformément aux présentes instructions.

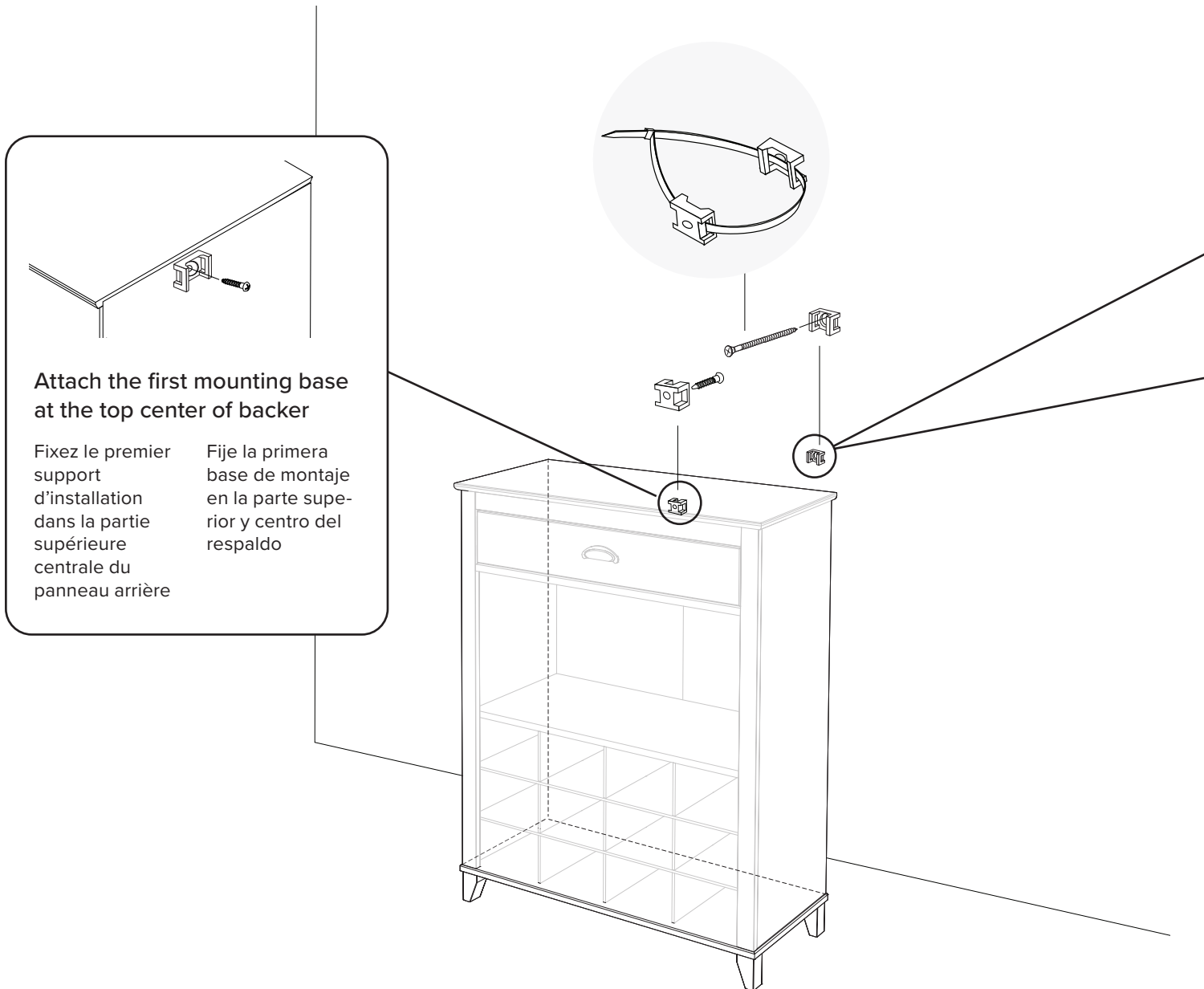

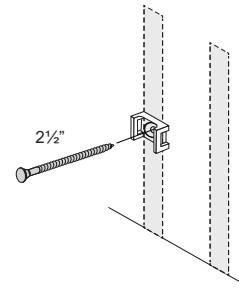
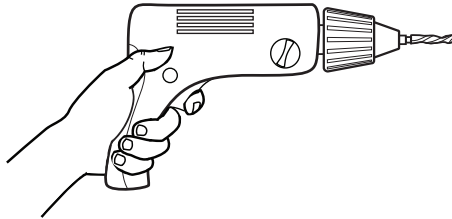
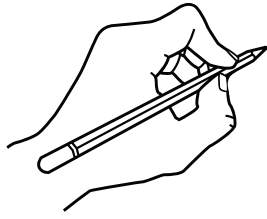

For walls constructed of wood with drywall

Pour les murs en cloison sèche avec montants en bois
Para paredes construidas de madera con paneles prefabricados

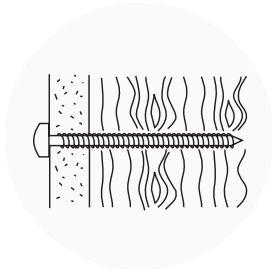

1. With a pencil mark location of second mounting base position
2. Drill pilot hole using an 1/8 inch drill bit 2 inches deep
3. Attach mounting base to wall using the 2 1/2 inch screw provided

1. À l'aide d'un crayon, marquez l'emplacement du deuxième support
2. Percez un avant-trou de 2 po de profondeur avec une mèche de 1/8 po
3. Vissez le support dans le mur à l'aide des vis de 2 1/2 po fournies

1. Con un lápiz marcar la ubicación de la segunda base de montaje
2. Perforar el agujero usando una broca de 1/8 pulgadas 2 pulgadas de profundidad
3. Montar el soporte a la pared utilizando los 2 tornillos de 2 1/2 pulgadas proporcionados

For walls constructed of drywall (unable to hit a stud)

Pour les murs en cloison sèche (où il est impossible de visser dans un montant en bois)
Para muros construidos de drywall (Sin travesaño)

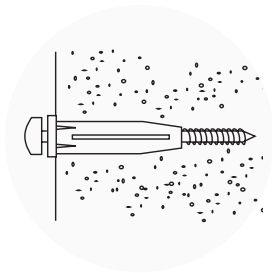

1. Drill pilot hole using a 5/16 inch drill bit only to the depth of drywall thickness
2. Using a rubber mallet or hammer insert wall anchor into drywall
3. Attach holder to wall anchor using 2 1/2 inch screw provided

1. Percez un avant-trou à l'aide d'une mèche de 5/16 po sans dépasser la profondeur de la cloison sèche
2. À l'aide d'un maillet en caoutchouc ou d'un marteau, insérez l'ancrage mural dans la cloison sèche
3. Vissez le support dans l'ancrage mural à l'aide des vis de 2 1/2 po fournies

1. Perforar el agujero utilizando una broca de 5/16 pulgadas solo a la profundidad del grosor del panel de yeso
2. Utilizando un martillo de goma o un martillo insertar el anclaje en pared de yeso
3. Fije el soporte de anclaje a la pared utilizando el tornillo de 2 1/2 pulgadas incluido

For walls constructed of concrete

Pour les murs en béton
Para muros construidos de hormigón

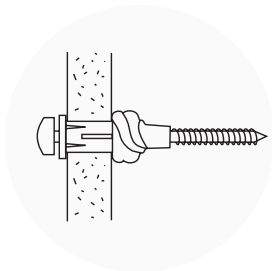

1. Drill pilot hole using a 5/16 inch drill bit 2 3/4 inches deep
2. Using a rubber mallet or hammer insert wall anchor into predrilled hole
3. Attach holder to wall anchor using 2 1/2 inch screw provided

1. Percez un avant-trou de 2 3/4 po de profondeur avec une mèche de 5/16 po
2. À l'aide d'un maillet en caoutchouc ou d'un marteau, insérez l'ancrage mural dans le trou
3. Vissez le support dans l'ancrage mural à l'aide des vis de 2 1/2 po fournies

1. Perforar un agujero de 2 3/4 de profundidad utilizando una broca de 5/16 pulgadas
2. Utilizando un martillo de goma o un martillo insertar el anclaje en el agujero preperforado
3. Fije el soporte de anclaje a la pared utilizando el tornillo de 2 1/2 pulgadas incluido

Night Stand with shelf

