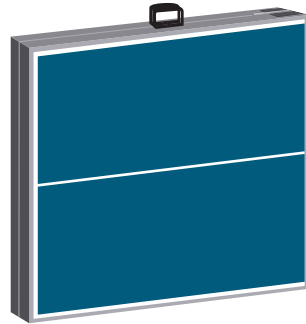

TABLE TENNIS

Set Includes:

- (1) Table Tennis Table
- (2) Paddles
- (1) Carry Case
- (4) Balls
- (1) Net

Table Tennis Table



Paddles

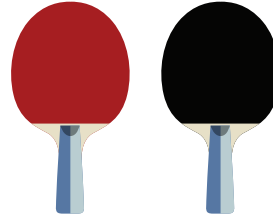

Carry Case

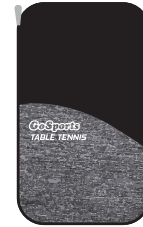

Balls

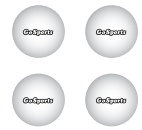

Net

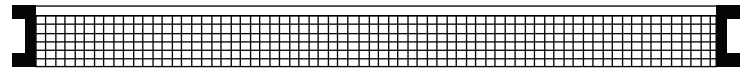

Assembly Instructions: (Requires 2 people)

1: Begin by fully unfolding the table, we recommend unfolding the table on its side.

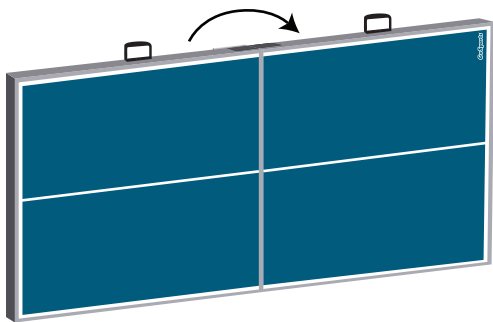

2: Unfold all the support legs fully until they securely lock in place.

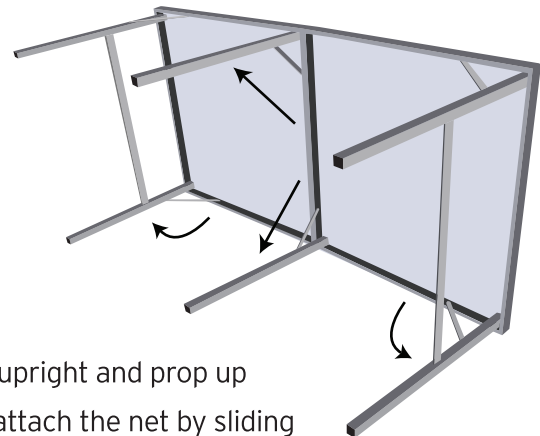

3: With a person on each side, turn the table upright and prop up the net poles on the sides of the table to attach the net by sliding the net loops over the poles.

- Ensure the white side is on top when attaching the net

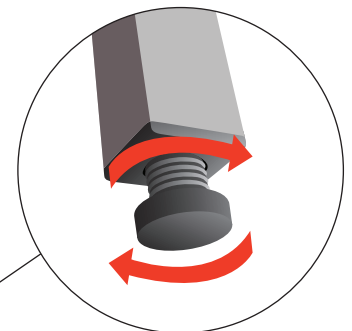
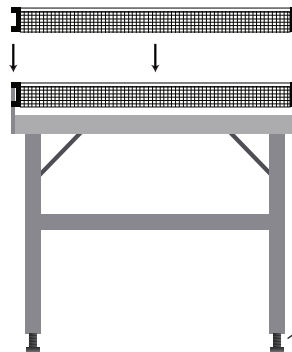

- Features adjustable feet for added stability on any surface

Game Care:

- Exercise caution when opening and closing the hinges on the table. They may be stiff right out of the box, but they will become smoother over time. You can add lubricant to the hinges if they are hard to open.
- The table is not weather-proof, so do not use or leave outdoors in the elements or get it wet
- The GoSports Table Tennis Table is designed to be extremely portable so you can play anywhere, however that means you shouldn't lean, sit or stand on it, as this will break the table

Playing the Game:

Overview:

In GoSports Table Tennis players rally back and forth and score a point when a player faults (see "Faults"). Either team can score regardless of who serves. Each game ends with the first side to score 21 points (or 11 points for shorter games) with at least a 2 point lead. A complete match is won when a team wins the best of any odd number of games (3, 5, 7).

STANDARD TABLE TENNIS RULES:

Players: 2-4 Players

Table Tennis may be played as singles (1-on-1) or doubles (2-on-2).

Serving:

- The serving side may be chosen with a coin toss or other similar method. The winner can choose whether or not to serve first.
 - If the serving player faults their first service, a second attempt is allowed.
- The serving player must hold the ball in an open palm then toss it up and hit the ball so that it first bounces in the serving player's service area and then bounces once in the opponent's service area before it is returned.

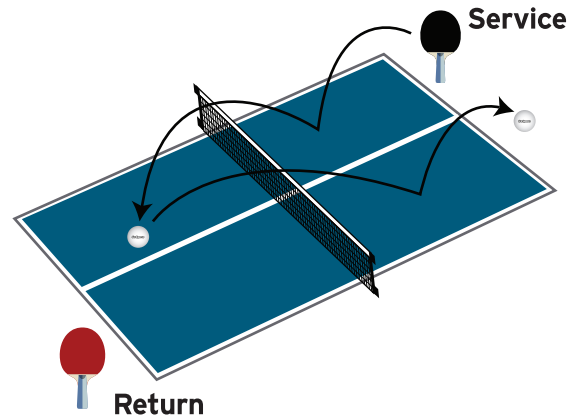

Faults: A fault occurs when play is stopped due to a rule violation such as:

- A serve or return is hit into and does not clear the net.
- The ball is hit out of the table boundaries
 - The edges of the table are still considered in bounds. The sides of the table are not.
- Failing to hit the ball before it bounces twice
- A player hits the ball before it crosses onto their side of the net

Scoring: One point is scored when a ball is not returned by the opponent or if the opponent faults, regardless of who serves (see "Faults").

Winning: Each match ends with the first side to score 21 points (or 11 points for shorter games) with at least a 2 point lead. The first player to win best 3 of 5 matches is the winner. Winning conditions can be adjusted for shorter or longer games when agreed upon by all players.

Customer Service:

If you have any questions or concerns regarding your GoSports Table Tennis Set, please reach out to us at info@PlayGoSports.com and we will get back to you right away. We stand behind our products 100% and want to make sure you get the full enjoyment that you paid for.