

ASSEMBLY INSTRUCTIONS

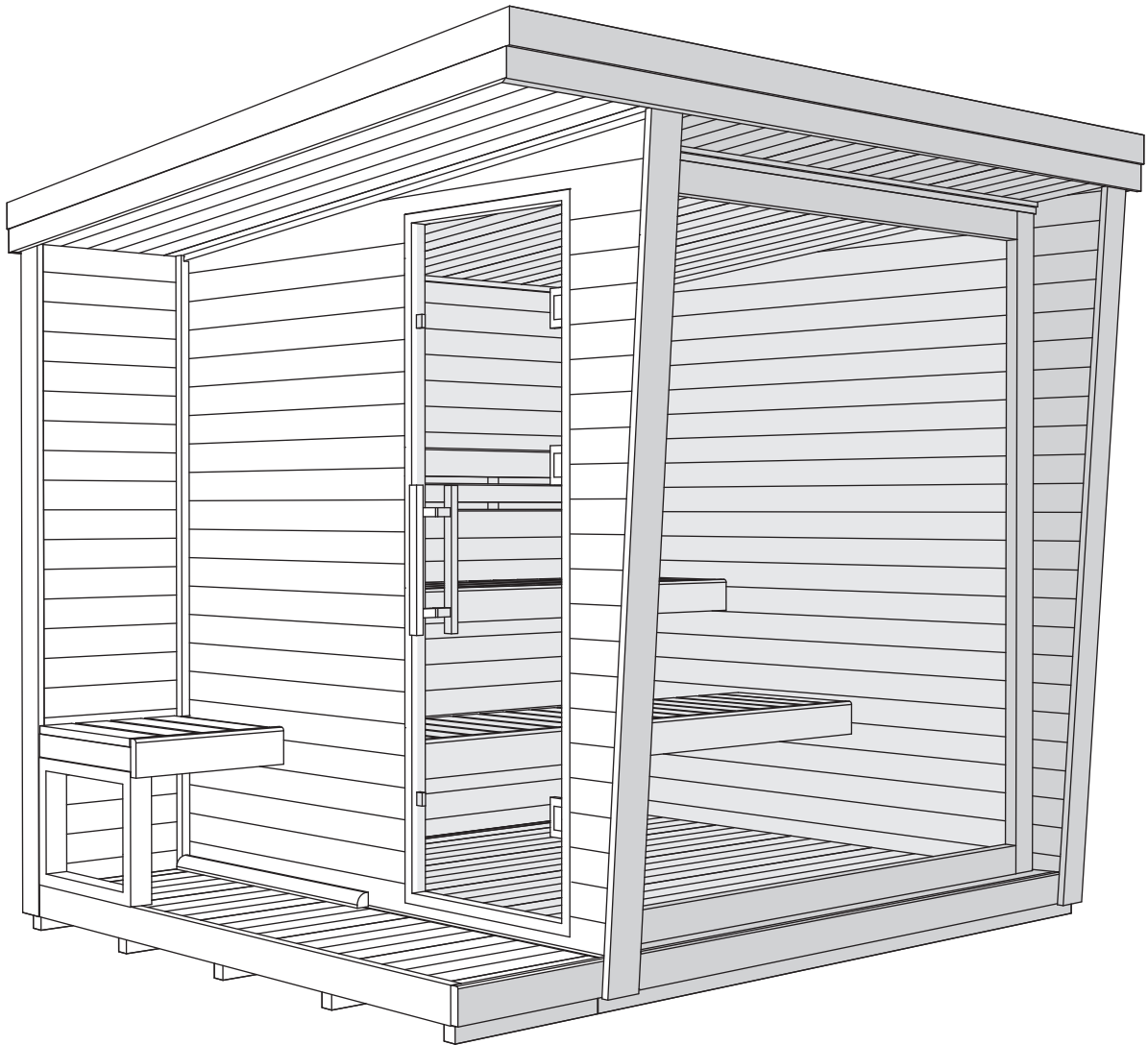

- Please read the instructions carefully before installation.
- After reading, keep them properly for future use.

CONTENTS

1. USER MANUAL OF THE SAUNA	01
2. MAINTENANCE OF THE SAUNA	02
3. WARRANTY	02
4. INSTRUCTIONS BEFORE USE	03
5. INSTALLATION TIPS	04
6. EXTERNAL DIMENSIONS	05
7. INTERNAL DIMENSIONS	06
8. OVERALL STRUCTURE	07
9. ACCESSORIES LIST	08
10. HARDWARE LIST	09
11. INSTALLATION STEPS	10
11.1 Seat and back panel installation	10
11.2 Right side panel installation	12
11.3 Left side panel installation	13
11.4 Front panel installation	14
11.5 Top panel installation	16
11.6 Stool installation	18

1.USER MANUAL OF THE SAUNA

1. It is recommended to install the sauna above ground level to prevent the legs of the sauna from coming into direct contact with the ground. Install a water-resistant material, such as bitumen strips, between the legs of the sauna and the base.
2. Make sure that the surface on which you install the sauna is levelled and stable both before and after installing the sauna. Otherwise, the doors of the sauna may not open and close properly.
3. During the first heating of the sauna, it must be constantly supervised and the doors should be kept open, as the stove emits a specific smell when first heated.
4. The maximum permitted temperature of the steam room is +90 °C. If heated to a higher temperature, the sauna may be overheated.
5. After each use of the sauna, it is recommended to keep the stove warm, the doors open, and the footrests up for a while to allow the sauna to dry from the inside. If necessary, the water on the floor should be directed to the drain with a floor scraper to avoid damage caused by excess humidity.
6. When the weather is humid and if the wood has expanded, the metal hoops around the sauna should be loosened to avoid breaking the clamps and jamming the doors. When the weather is less humid and the wood has dried, the metal hoops around the sauna should be tightened from Tighten the nut so the hoop is under slight pressure. The hoop must be pressed fully against the wood so that it cannot be pulled away from the walls of the sauna.
7. The interior door should be regulated from the stopper and, if necessary, the hinges. If this is not a sufficient solution, remove the trims of the door and unscrew the screws them. This will relieve the pressure on the door.
8. Locing the sauna door from the inside is prohibited.
9. In order to avoid damage caused by the weight of snow, any snow should be removed from the roof of the sauna. Keep in mind that the roof covering should not be damaged during snow removal.
10. If your sauna has lighting, install a outdoor power cable . The power cable of the sauna must be connected to a residual-current circuit breaker! Consult an electrician if necessary.

2.MAINTENANCE OF THE SAUNA

1. The interior surfaces of the sauna, the window frames of the steam and washing room, and the frames of interior doors must be treated with a special substance before initial use to protect them from humidity and dirt and extend the useful life of the sauna. Later, this should be done once or twice a year.
2. Before initial use of the sauna, the benches and footrests must be treated with a protective oil to extend their useful life. Later, this should be done once or twice a year.
3. Before initial use of the sauna and once a year after that, the door, doorframe, threshold, and window frame of the anteroom as well as the floors of the washing room and anteroom should be treated with the lacquer.
4. The outer surface of the sauna is coated with a first protective coating during production. The second coating should be applied approximately two months after purchasing the sauna to extend its life and maintain its appearance.
5. We are not responsible for damage to your sauna due to insufficient or complete lack of maintenance.

3.WARRANTY

We supply one year warranty to all parts. Warranty covers manufacturing defects only and does not include damage caused by improper use, lack of maintenance, or neglect. Proper maintenance of the sauna is essential to ensure optimal performance. Failure to perform routine maintenance as per the manufacturer's guideline may result in voided warranty and no eligibility for compensation in case of damage or leaks.

4. INSTRUCTIONS BEFORE USE





1. A member of the high blood pressure, heart disease, high blood pressure do not sauna.
2. Who has a cold should not be sauna. because the sauna room hidden cryptococcus bacteria can enter human body through respiratory tract, such as easy to cause pneumonia, etc.
3. Do not sauna when overwork and can't sleep in sauna room. People with poor muscle tone when they are tired, reduce the stimulation of cold and hot resistance ability, easy to cause collapse when sauna.
4. Do not sauna when on an empty stomach, lest cause cardiovascular collapse. Should not be sauna after overstrain brain or strenuous exercise. it can cause brain anemia or shock.
5. It is not suitable for sauna not after half an hour feast, because the high temperature make the skin vasodilation, blood backflow in great quantities, which affect the blood supply of the digestive organs, interfere with digestion and absorption of food.
6. Do not sauna after drinking. After heavy drinking, it can make the brain systems at the mercy of the function to drop, at this time if sauna, under the effect of alcohol, a amount of sweat will make human body caused by rapid filtration syncope.
7. Do not wear jewelry when sauna, like jade, necklaces, watches, etc are easy absorption of heat may be burn the skin.
8. Do not apply cosmetics, because it can block pore, prevent sweat evaporation.
9. Sauna is not suitable for the elderly, sitting in a sauna room, the body sweat more, the blood becomes sticky, it is easy to form thrombus, cause of various cardiovascular diseases. Especially the elderly, their body temperature regulating center not too sensitive, so not suitable for sauna.
10. Sauna should not be too long, if too long, excessive sweating can make the person to exhaustion; temperature is too high, can be difficulty breathing. In general, in the sauna room should be come out every 5-10 minutes. Setting temperature personalized, it is recommended that the dry steam temperature between 60 °C to 80 °C make the person feels more moderate.
11. Do not immediately come with cold air after sauna, prevent big difference temperature cause vascular contractions induced stroke.
12. Go with partner sauna, should be timely supplement moisture, do not wait until thirsty to drink.
13. Keep awake when sauna, if have shortness of breath, dizziness and other symptoms should immediately stop sauna, lie down in a better air circulation place. drink some cold boiled water, not drink too low water temperature.
14. Do not get up too fast and too hard, be sure slow up and adequate rest.

5. INSTALLATION TIPS

Instructions before assembly:

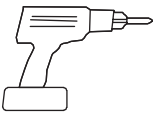
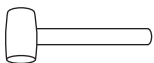
1. At least two people are required to assemble the sauna.
2. Assembly location: check whether the ground or platform is horizontal. and slight slope will not affect the assembly and use of sauna. but if the slope is evident, a pad is needed to keep the sauna level.
3. All screw heads to assemble sauna must be completely inserted into wood to avoid scratching skin during use. If you want to assemble accessories provided by other companies to the sauna, try to avoid metal accessories. or insulate them.
4. Please find qualified electricians to install the electrical elements in sauna.

Please prepare the following aids:

					
Power Drill *1	Plastic Hammer *1	Adjustable Wrench *2	Tape *1	Bar Level *1	Pencil *1

Installer recommendations:

1. It is recommended that two people work together to install for higher installation efficiency.
2. Improve the safety of the assembly process and better complete the alignment and lifting operations.

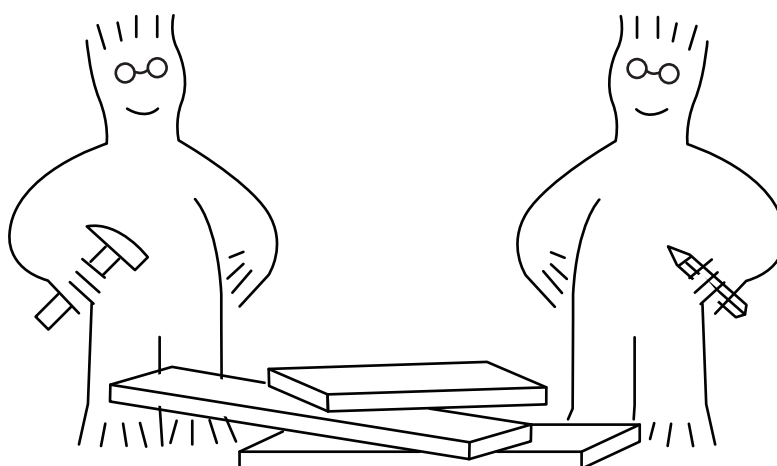

Installation precautions:

When tightening the screws, avoid over-tightening to damage the plate.

6.EXTERNAL DIMENSIONS

- Front view (Unit: mm)
size:2500*2200*2200

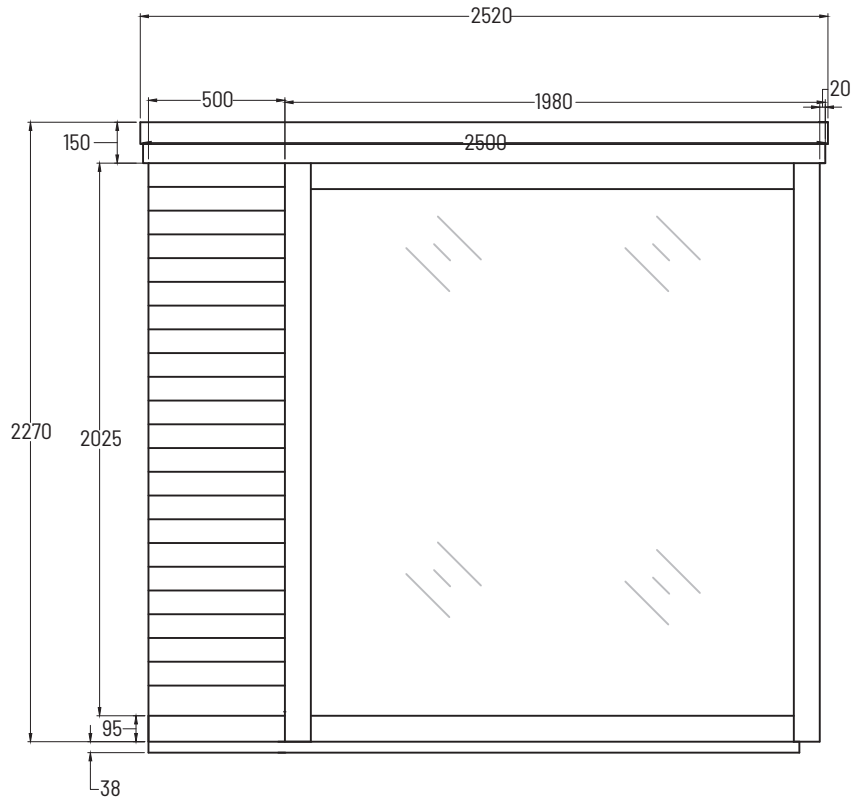

- Side view (Unit: mm)

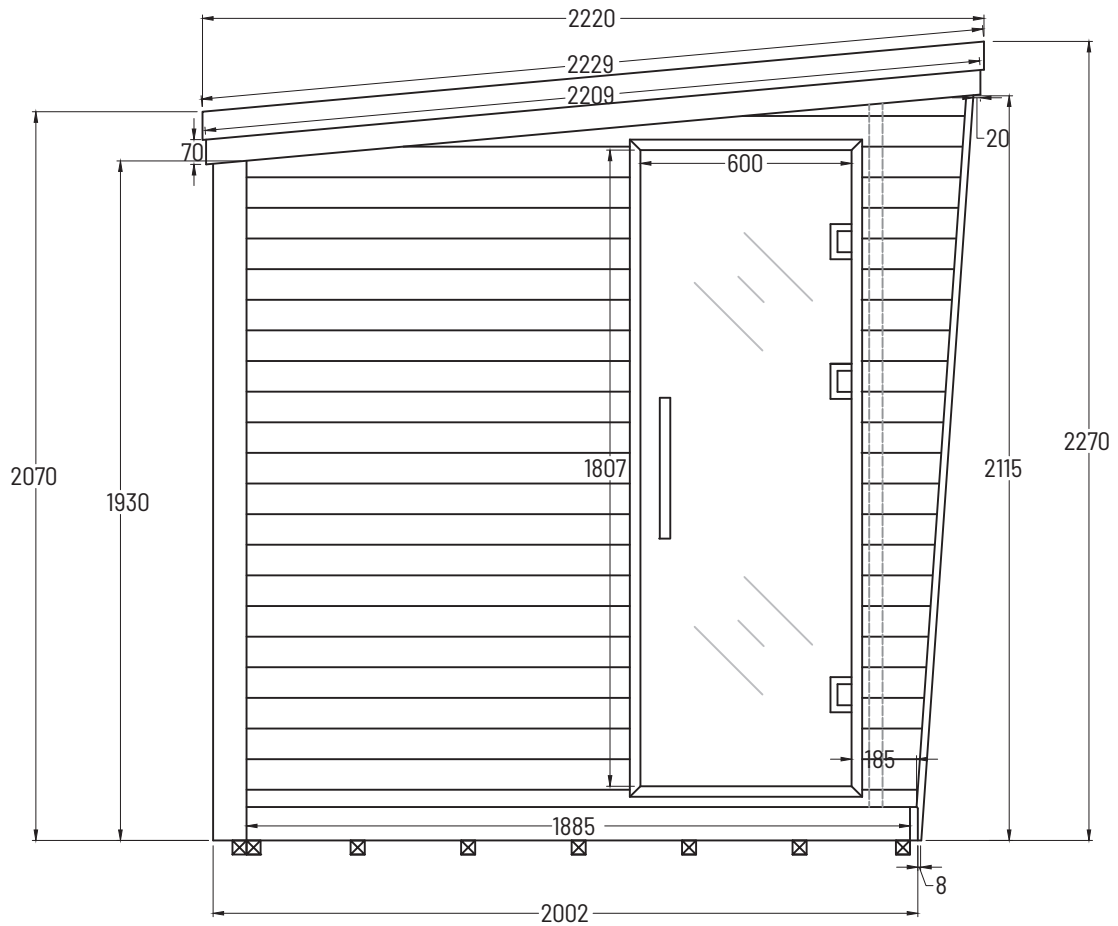

8.OVERALL STRUCTURE

- Overall exploded view.

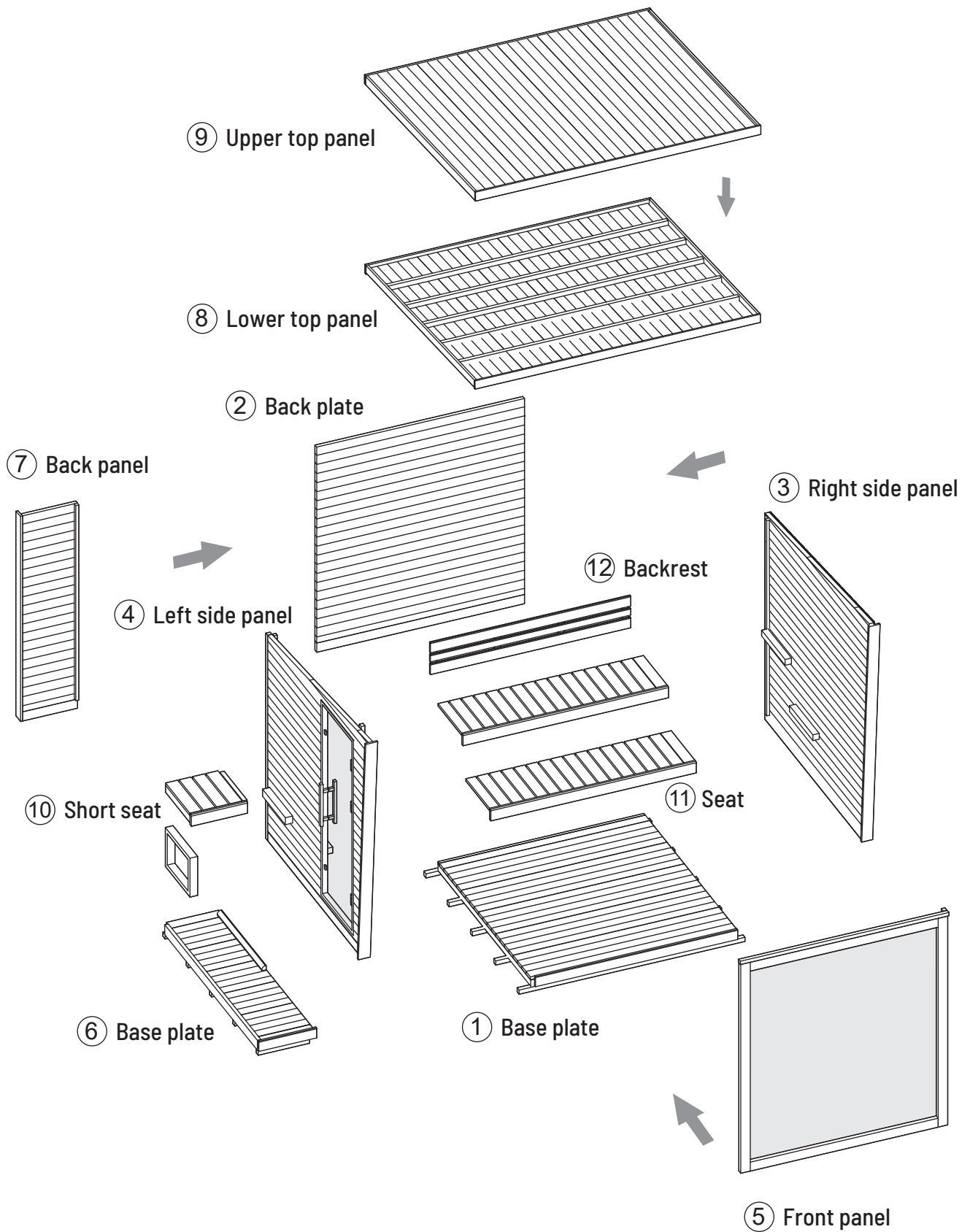



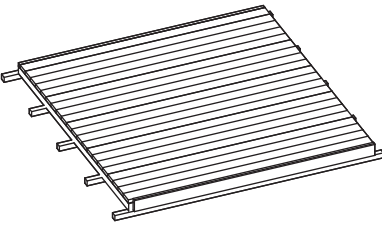
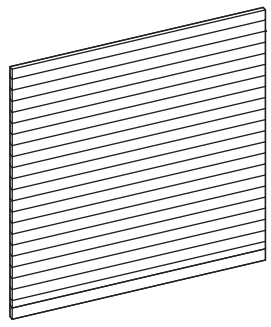
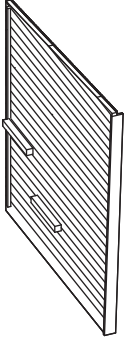
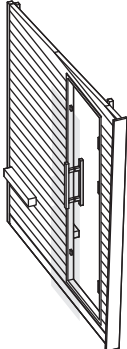
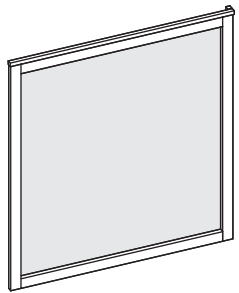
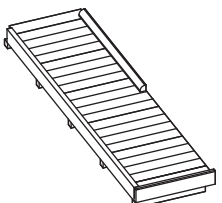
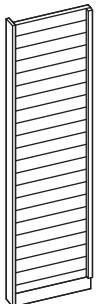
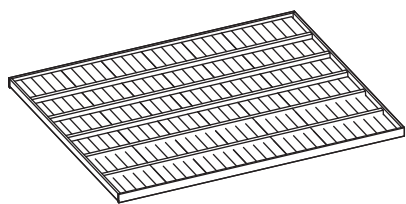
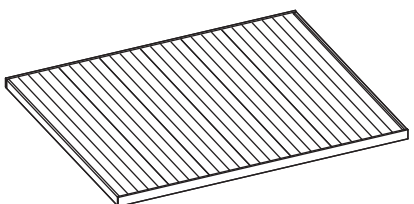
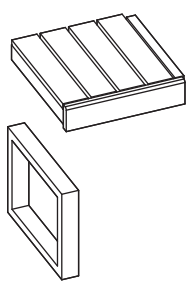
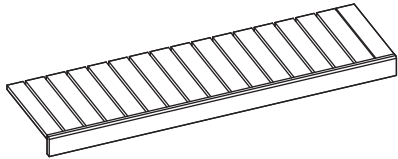
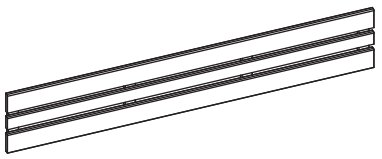

9.ACCESSORIES LIST

- Overall parts list

<p>① Large base plate</p>  A large rectangular plate with a grid of aluminum tiles, shown from a perspective view.	<p>② Large back plate (with aluminum tiles)</p>  A large rectangular plate with a grid of aluminum tiles, shown from a perspective view.	<p>③ Right side plate (with aluminum tiles)</p>  A rectangular plate with a grid of aluminum tiles, shown from a perspective view.
<p>④ Left side plate</p>  A rectangular plate with a grid of aluminum tiles, shown from a perspective view.	<p>⑤ Front panel</p>  A rectangular panel with a white center and a dark border, shown from a perspective view.	<p>⑥ Small base plate</p>  A small rectangular plate with a grid of aluminum tiles, shown from a perspective view.
<p>⑦ Small back plate (with aluminum tiles)</p>  A small rectangular plate with a grid of aluminum tiles, shown from a perspective view.	<p>⑧ Lower top plate</p>  A rectangular plate with a grid of aluminum tiles, shown from a perspective view.	<p>⑨ Upper top plate</p>  A rectangular plate with a grid of aluminum tiles, shown from a perspective view.
<p>⑩ Short seat</p>  A short seat with a grid of aluminum tiles, shown from a perspective view.	<p>⑪ Long seat</p>  A long seat with a grid of aluminum tiles, shown from a perspective view.	<p>⑫ Backrest</p>  A long backrest with a grid of aluminum tiles, shown from a perspective view.

10.HARDWARE LIST

- Hardware List:

A		Screws 4x70mm	×25
B		Screws 4x60mm	×16
C		Screws 4x50mm	×16
D		Wooden cork	×20

- Quantity used for each part:

Wall connection	Screws 4x70mm	×25
Base panel connection	Screws 4x50mm	×3
Stool mounting	Screws 4x60mm	×16
Backrest	Screws 4x50mm	×4
Lower top panel mounting	Screws 4x50mm	×9

11. INSTALLATION STEPS

1 Install the base.

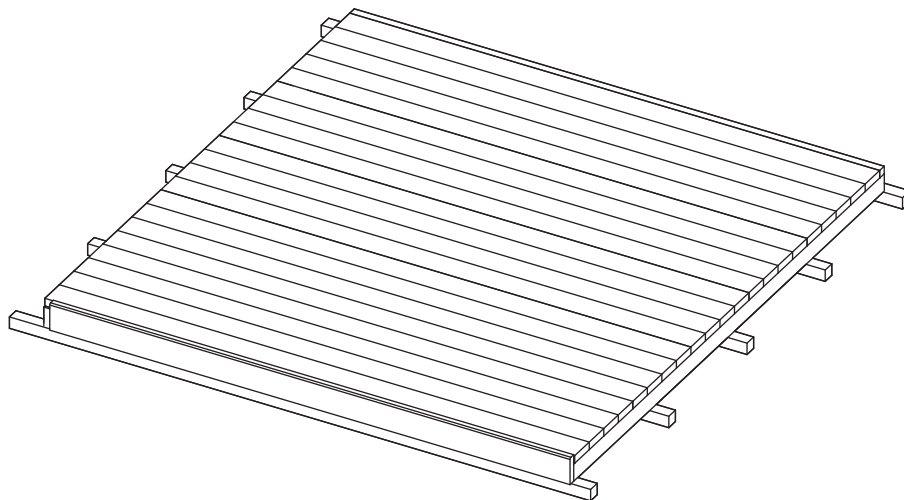
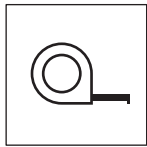

2 Attach the backrest to the large back panel and screw in place.

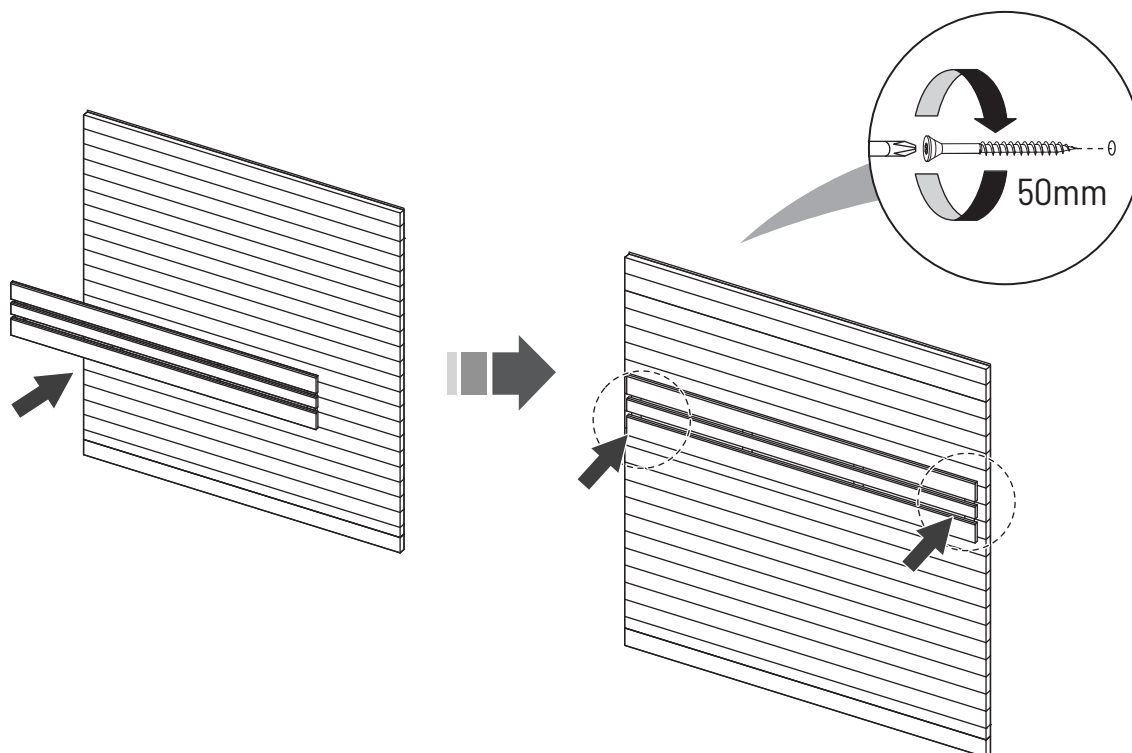
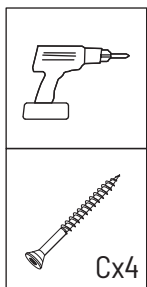

2 Connect the large back panel to the base.

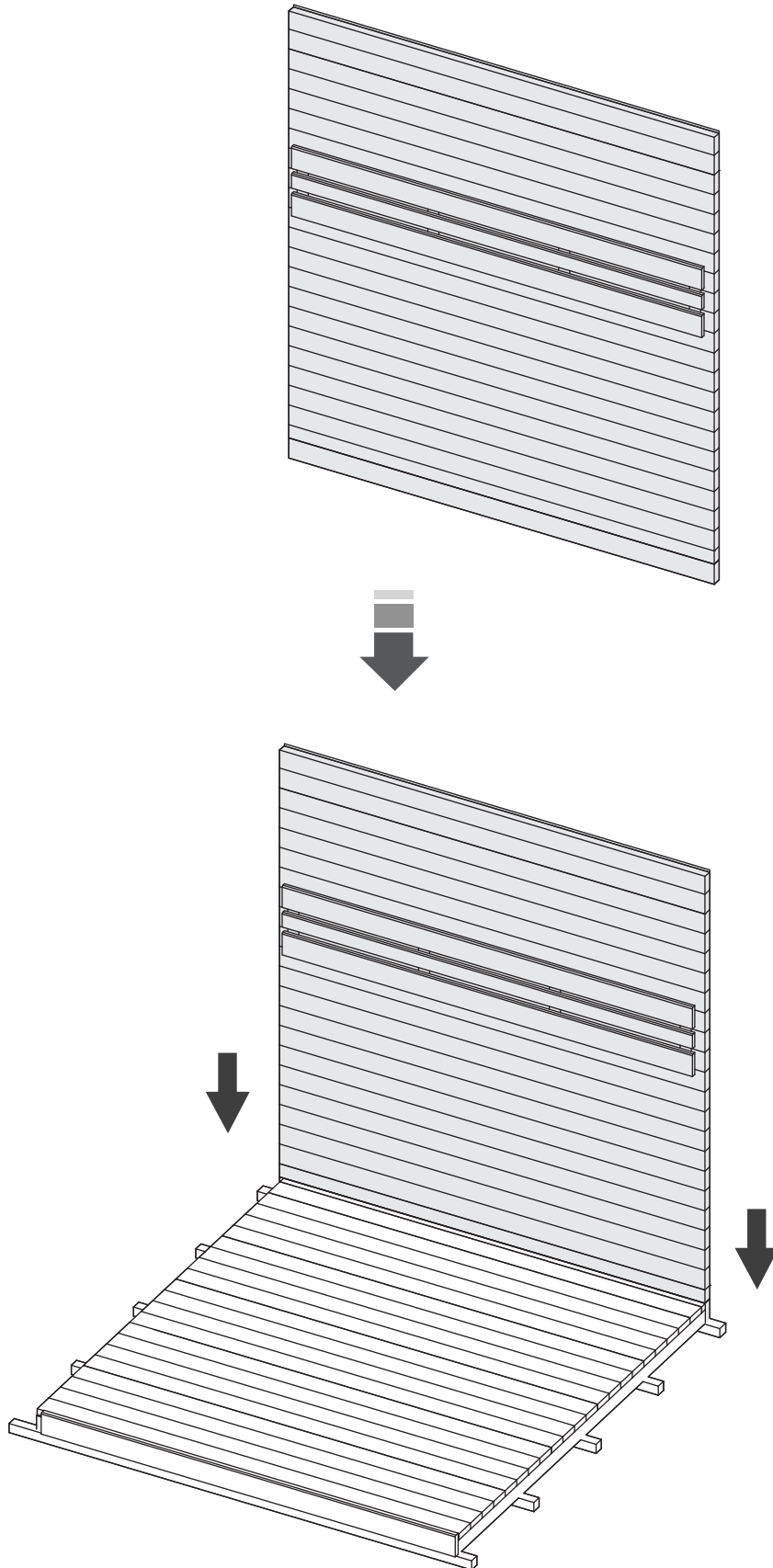
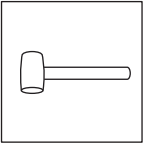

3 Install the right side panel and screw it in to the back panel.

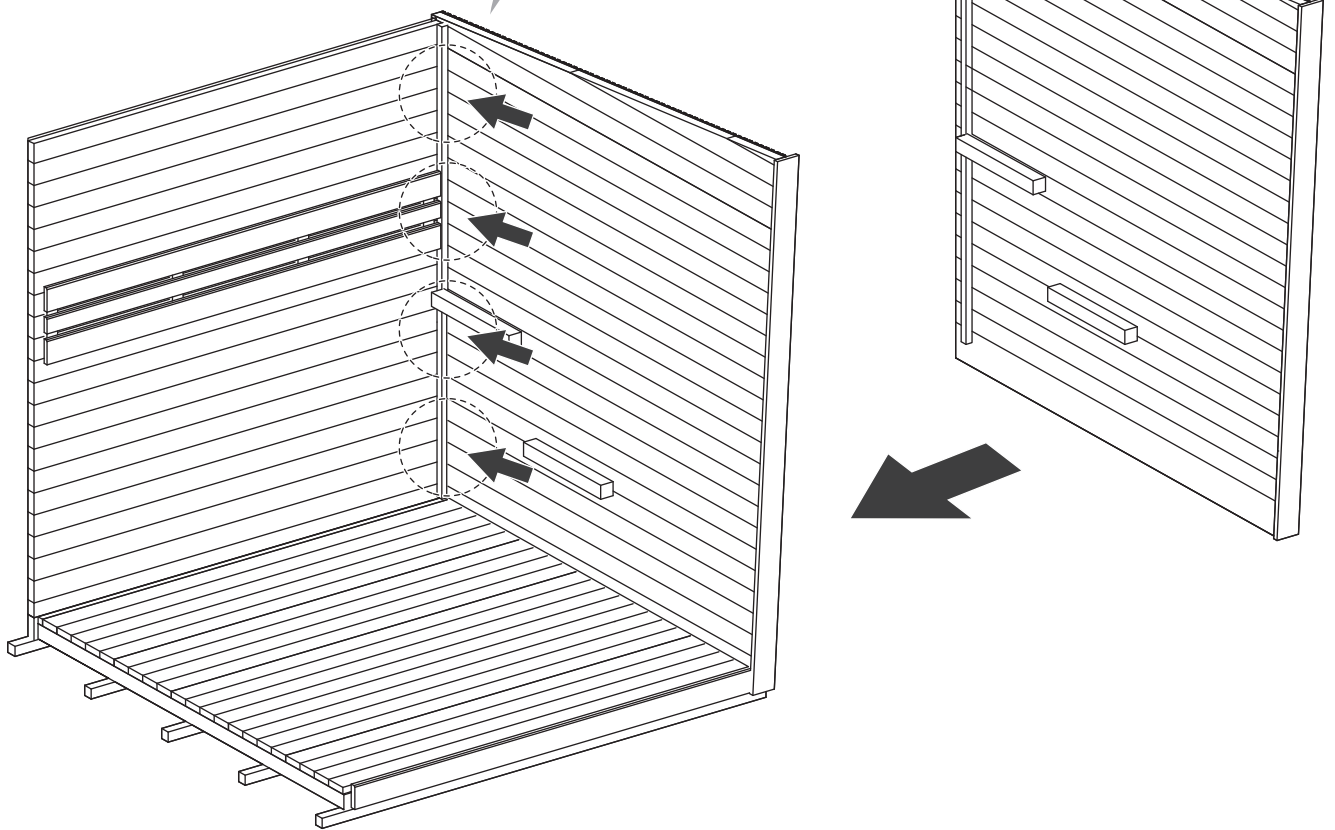
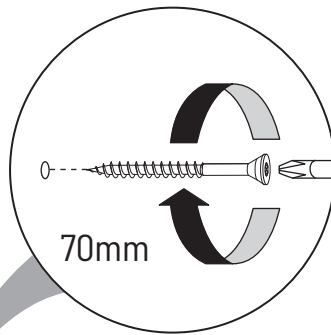
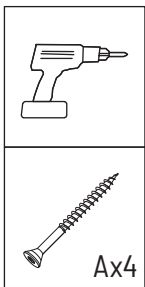

4 Attach the left side panel and screw it in.

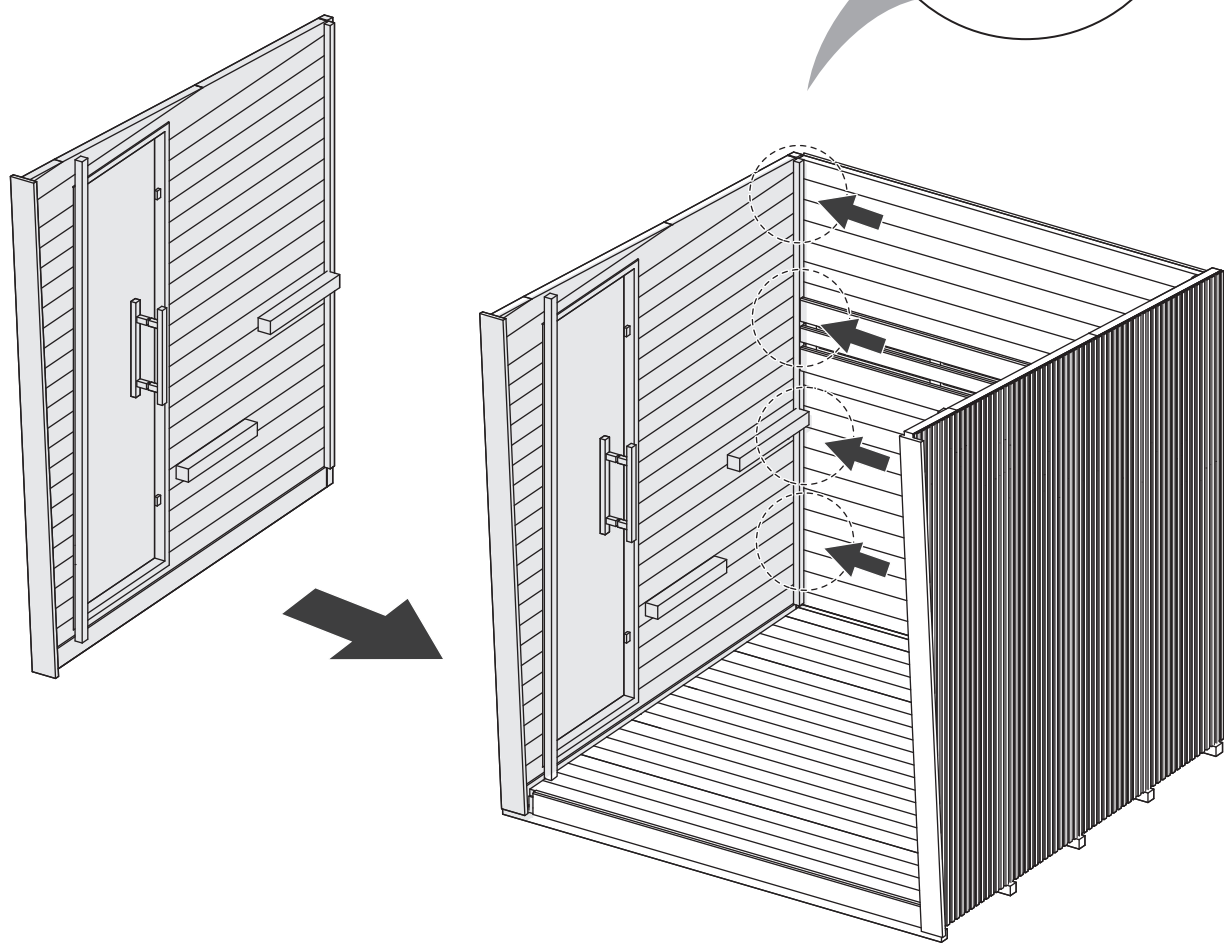
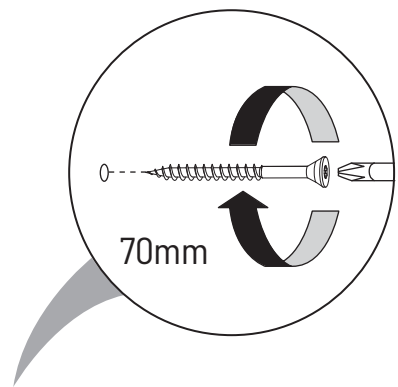
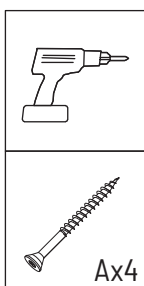

5 Attach the front panel to the left and right side panels.

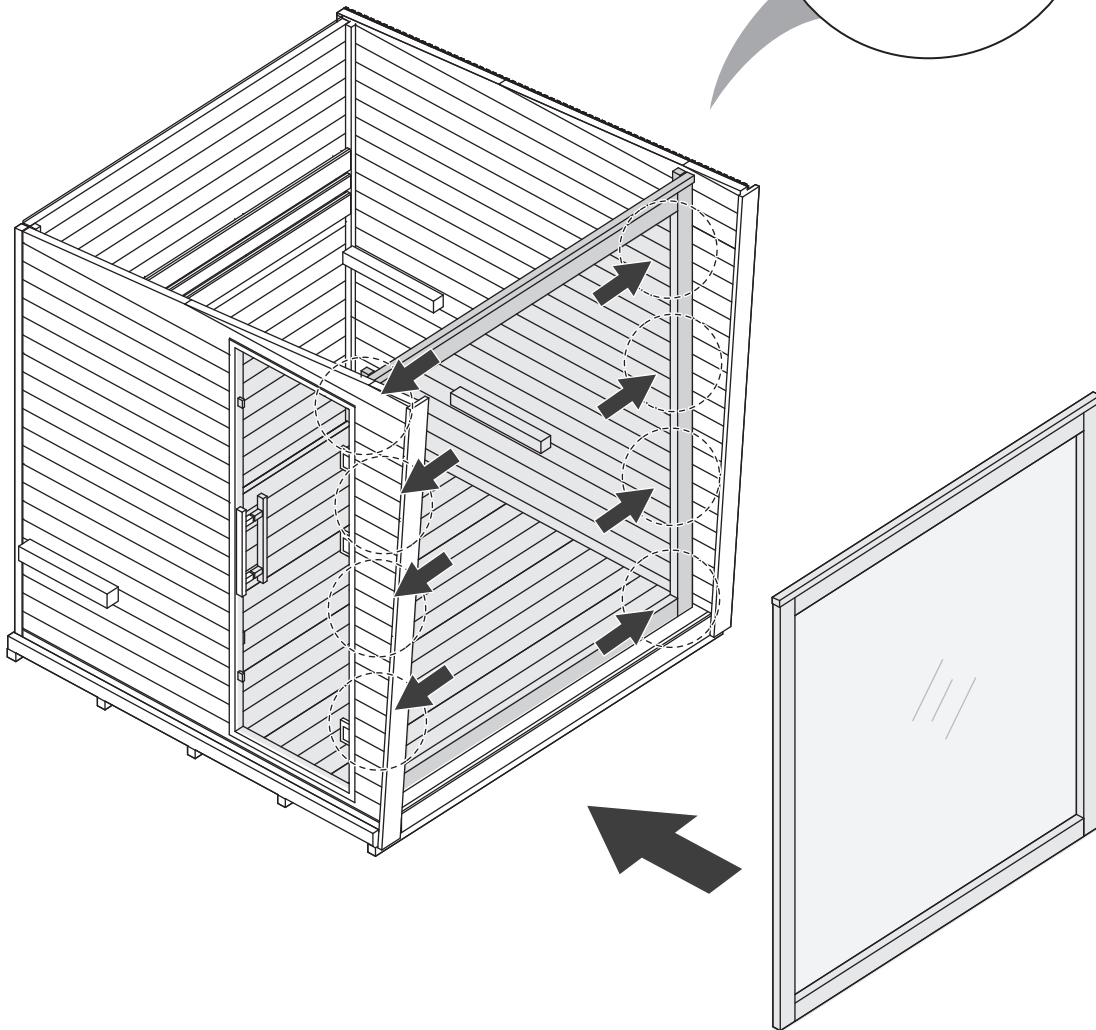
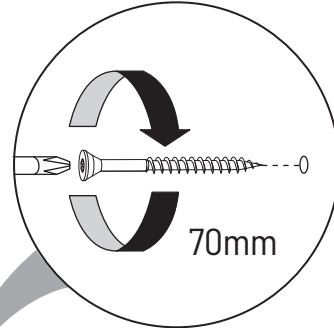
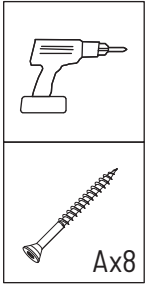

6

Install the small seat panel on the left and screw it in.

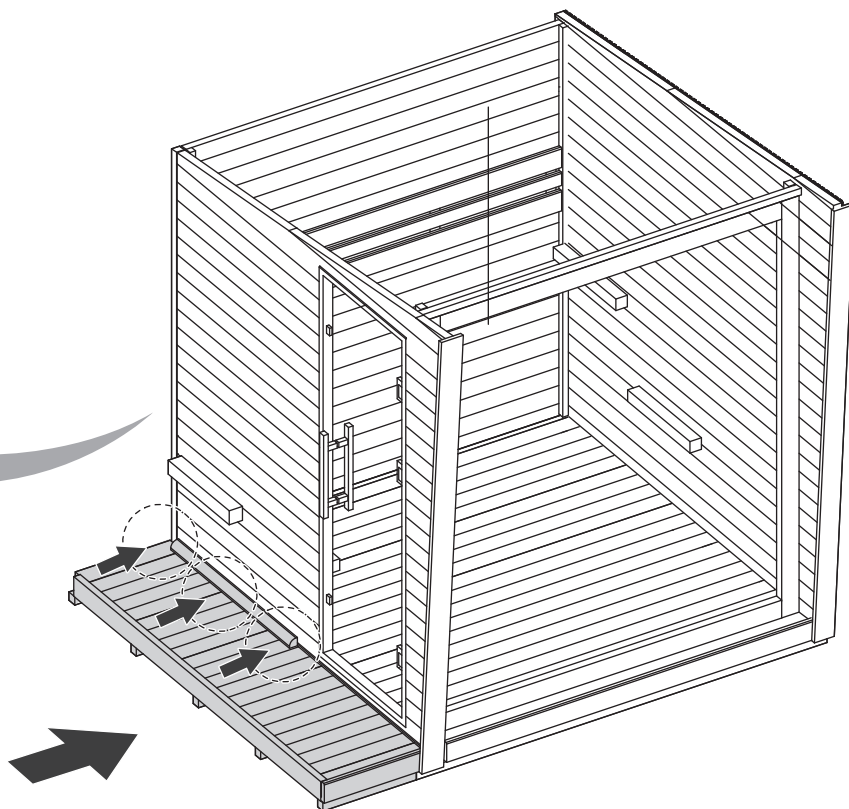
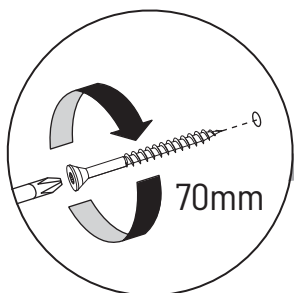
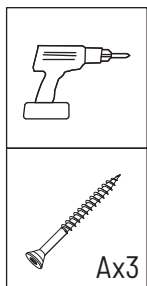

7

Install the small back panel on the left and screw it in.

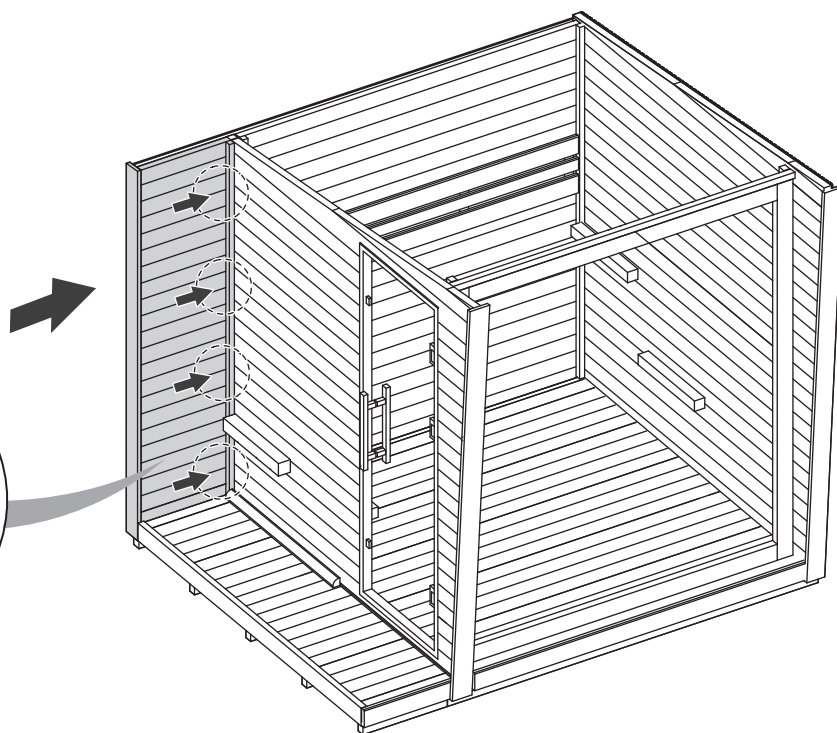
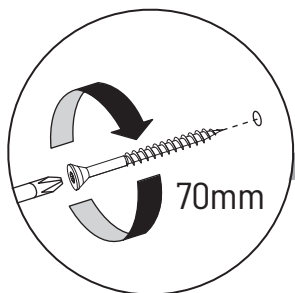
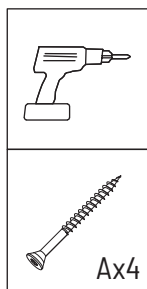

8 Install the lower top panel and screw it in.

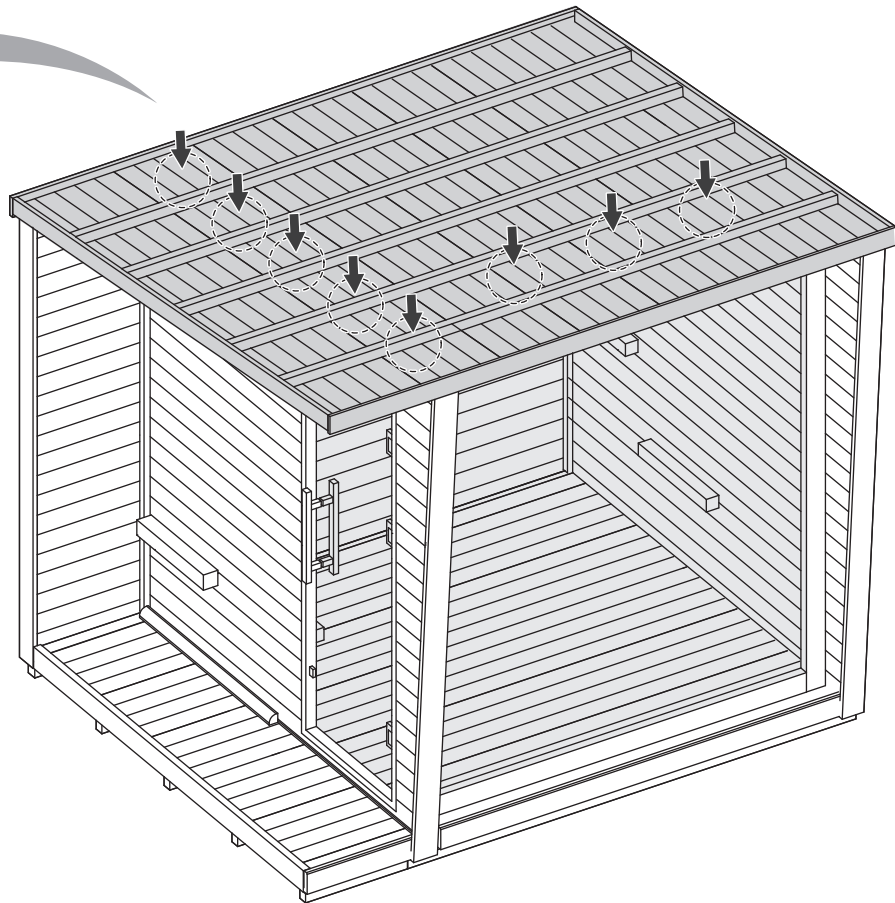
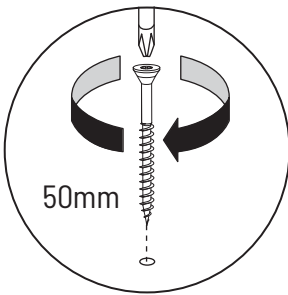
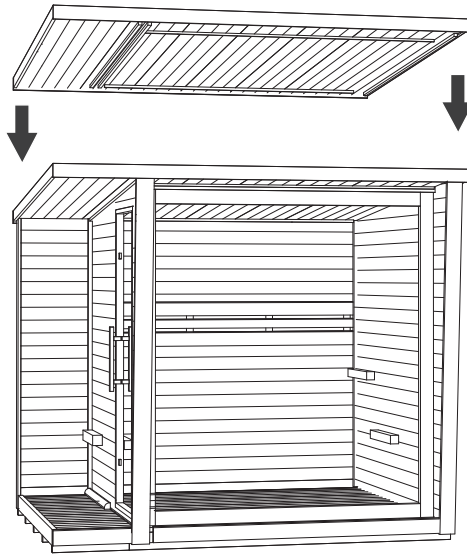
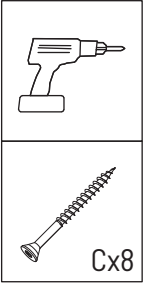

9

Install the upper top panel over the lower top panel.

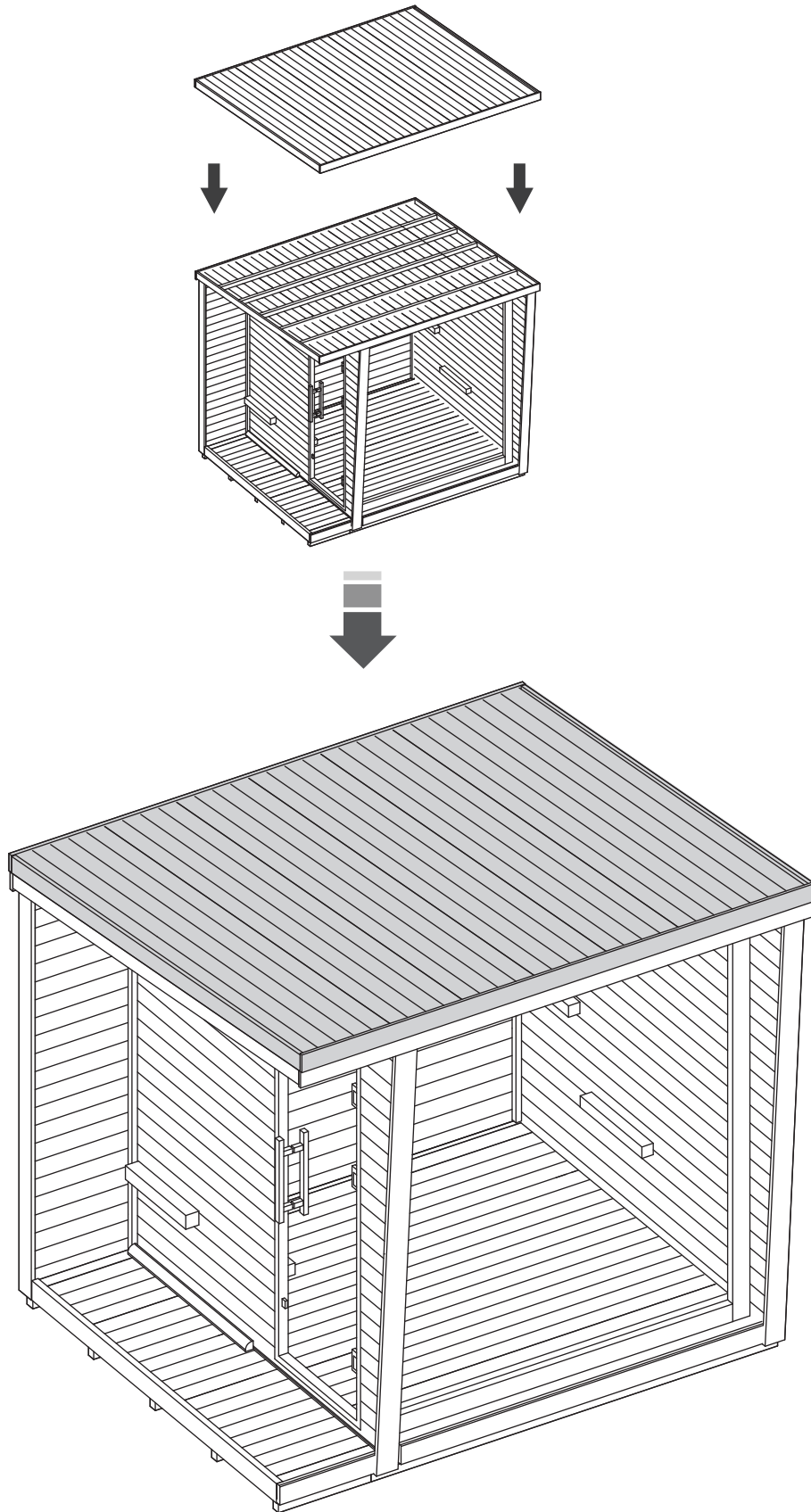
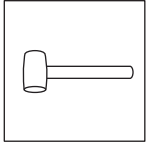

10 Install the small stool on the left. First, install the support frame, then place the seat panel on top and screw it in.

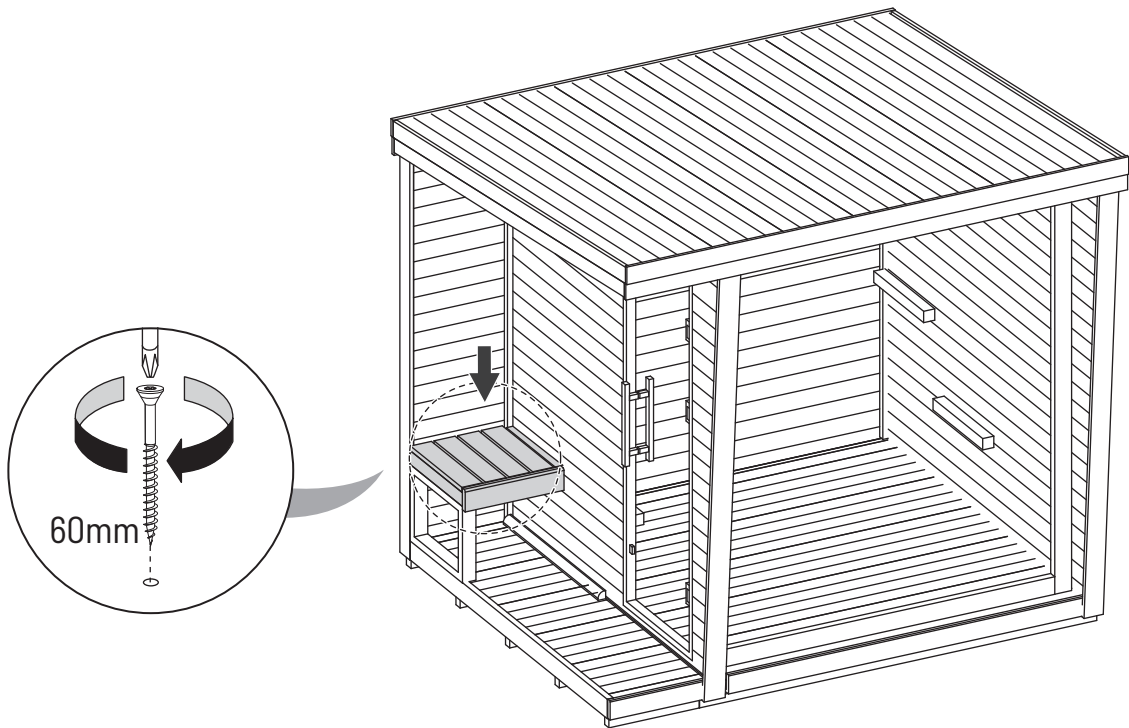
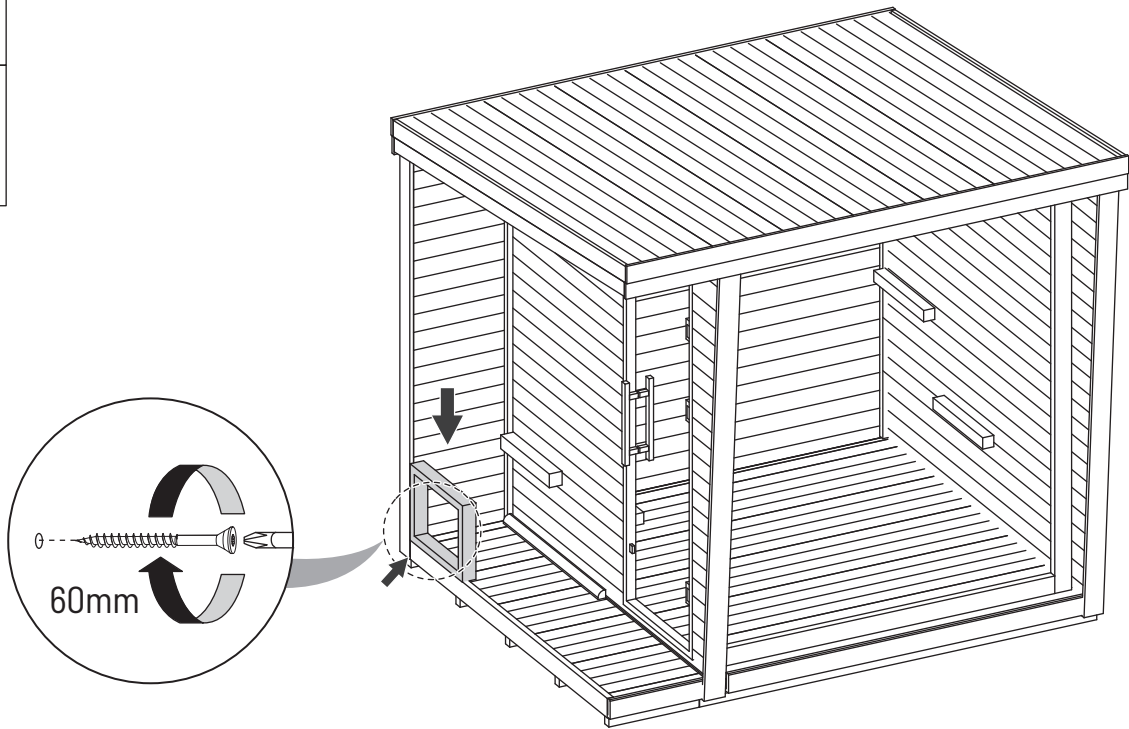
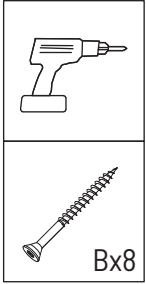

- 11** Install the inner bench and screw it in.
Connect the wiring.
Installation is complete.

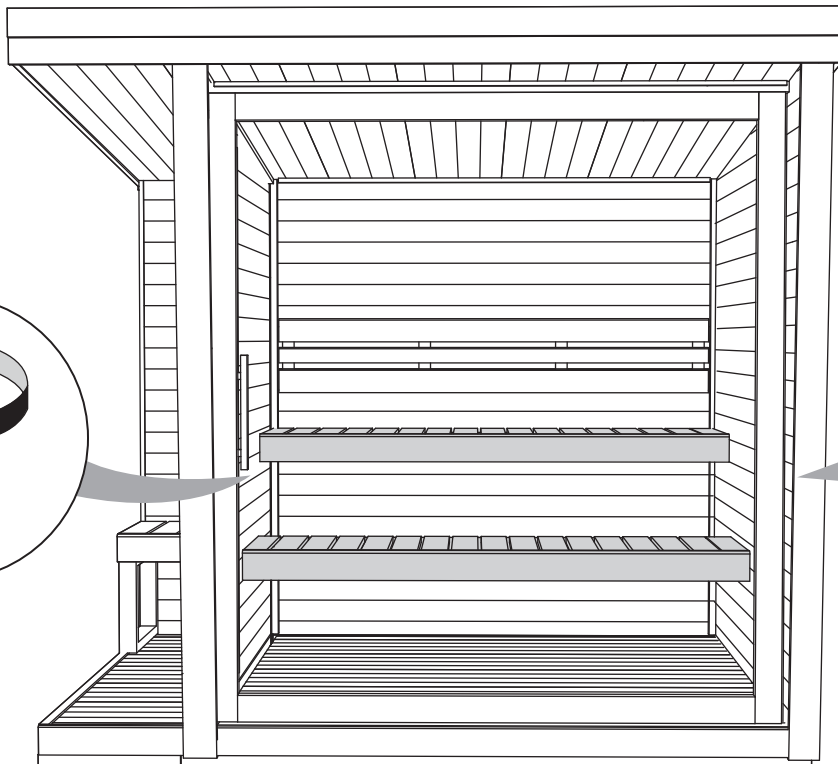
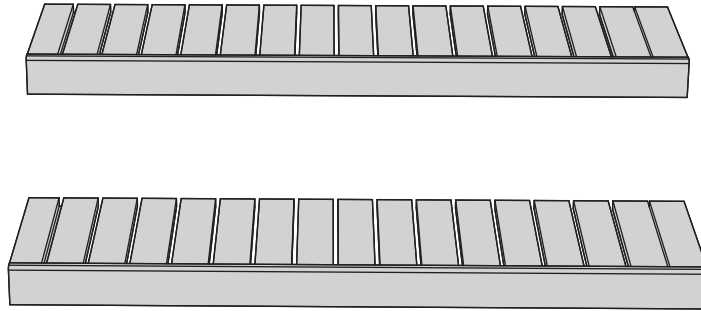
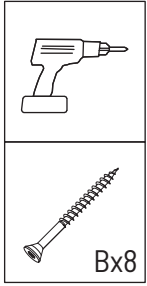

60mm

Connect the line.

 Special statement:

All contents in this manual have been carefully checked. If there are any printing errors or misunderstandings in the content, the company reserves the right to interpret; if there is a product technology or software upgrade, it will be included in the new version of the manual without further notice; if there is any change in the appearance and color of the product, the actual product shall prevail.

Dear customer, thank you for your patronage! If you have any questions or concerns, please feel free to contact us.