

# ASSEMBLY INSTRUCTION (Instructions de montage)

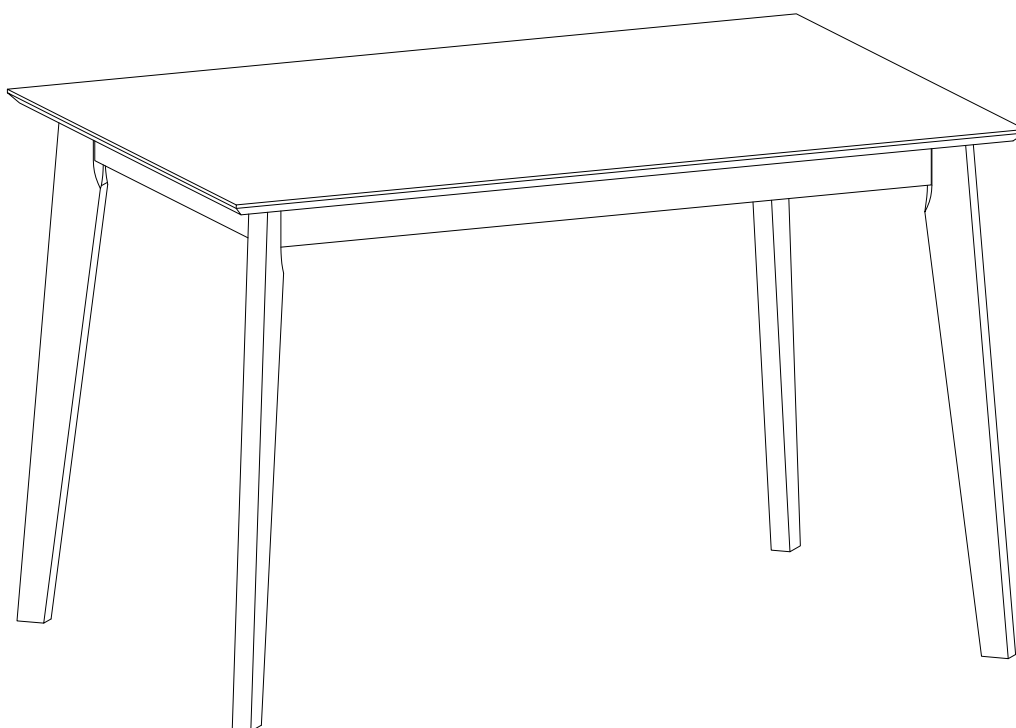

NOTE: 50% TIGHTEN BEFORE FIXING ALL BOLTS  
(REMARQUE : SERRER 50% AVANT DE FIXER TOUS LES BOULONS)

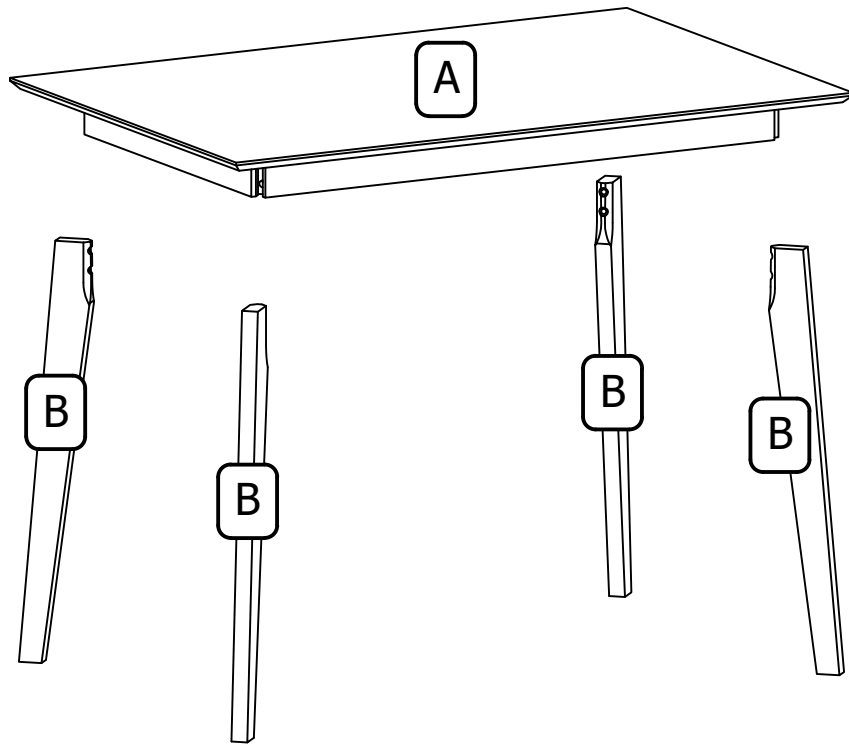

**Notice:**

1 50% Tighten before fixing all screws, Allen wrench is recommended instead of an electric drill.

2 Place the item on a flat ground to adjust and make sure it remains  
3 stable.

4 Tighten up all screws with tools gradually.

If the screws are not aligned with holes during assembly, please loosen  
5 all the other screws to 50% and continue the assembly process.

If the item is not stable, please loosen all the screws, adjust it on a flat  
6 ground and tighten up all screws again.

Note : If one or some screws are fully tightened during assembly, chances are the others will not be aligned with holes. In addition, all the holes are designed to be relatively larger to provide more space for the adjustment of the screws.

## PART LIST

A

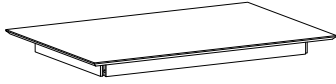

Tabletop (1PC)  
Plateau de table (1PC)

B

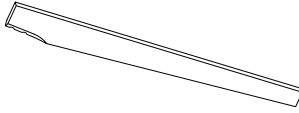
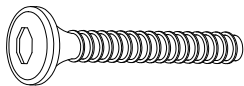

Table Leg (4PCS)  
Pied de table (4PCS)

## HARDWARE LIST

1



JCBB M8 x 70 (8PCS)  
Boulon JCBB M8 x 70 (8PCS)

2

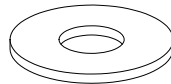

Flat Washer M8 (8PCS)  
Rondelle plate M8 (8PCS)

3

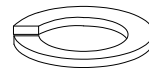

Spring Washer M8 (8PCS)  
Rondelle élastique M8 (8PCS)





4

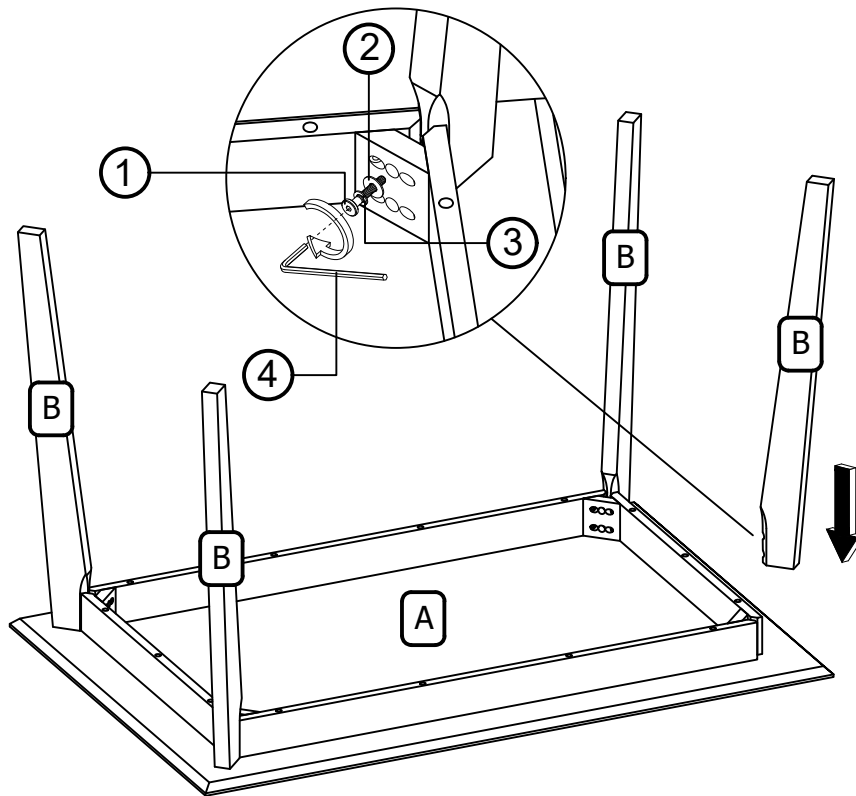

Allen Key M4 (1PC)  
Clé Allen M4 (1PC)

# STEP 1



1		JCBB SCREW M8 X 70MM Boulon JCBB M8 x 70	8pcs	3		Spring Washer M8 Rondelle élastique M8	8pcs
2		Flat Washer M8 Rondelle plate M8	8pcs	4		Allen Key M4 Clé Allen M4	1pc

# STEP 2

