

NOTICE

- * Please make sure that you have all parts indicated and they are in good condition before you begin assembly of this item. Refer to part list and hardware list below for guidance.
- * This item should be assembled on a soft surface to prevent scratching the finish during assembly.
- * This item may require periodic tightening.
- * If you are having difficulty, our friendly Customer Care team is always here to help.

PREPARATION

- * Before beginning assembly of product, make sure all parts are present. Compare parts with part contents list and hardware contents list.
- * If any part is missing or damaged, do not attempt to assemble the product.
- * Estimated Assembly Time: 15 minutes.
- * Tools Required for Assembly (included): Allen Key

CARE AND MAINTENANCE

WOOD CARE: Adhesive felt pads should always be applied to areas of furniture which make direct contact with flooring, said application will prevent damage to the furniture and or surfaces on which the furniture lies. Objects placed on articles of furniture should rest on non abrasive material as to prevent damage to the wood finish. Wipe up spills immediately and avoid common hazards such as hot dishes, harsh solvents and abrasives. Cleaning should be done with a soft lint free cotton cloth dampened with water or furniture polish.

UPHOLSTERY CARE: To prevent overall soiling, frequent vacuuming or light brushing is recommended. Cushions and pillows should be turned on a weekly basis. Down-filled cushions should be brushed rather than vacuumed. Spot clean, using a mild water-free solvent or dry cleaning product. Only a professional cleaner should undertake a complete overall cleaning. The use of steam or water-based cleaners may cause excessive shrinking or staining.

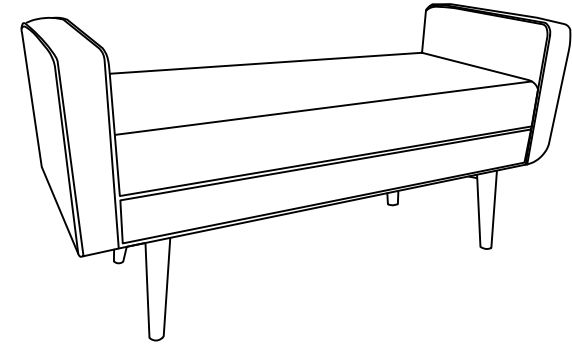

Product Dimensions: 49"W x 18"D x 25"H

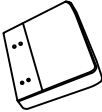
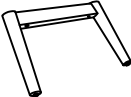

Weight Capacity : 550 lbs
Warning : Do not stand on the product
Warning : Do not over torque bolts

Part List and Hardware List

PIECE	DESCRIPTION	PICTURE	QTY
A	Seat Cushion		1X
B	Armrest		2X
C	Frame Leg		2X

PIECE	DESCRIPTION	PICTURE	QTY
HW1	Hex Socket Bolt	 5/16"-18x2"	16X
HW2	Allen Key	 4mm	1X

PREPARATION

- * Before beginning assembly of product, make sure all parts are present. Compare parts with part contents list and hardware contents list.
- * If any part is missing or damaged, do not attempt to assemble the product.
- * Estimated Assembly Time: 15 minutes.
- * Tools Required for Assembly (included): Allen Key
- * If you are having difficulty, our friendly Customer Care team is always here to help.

1

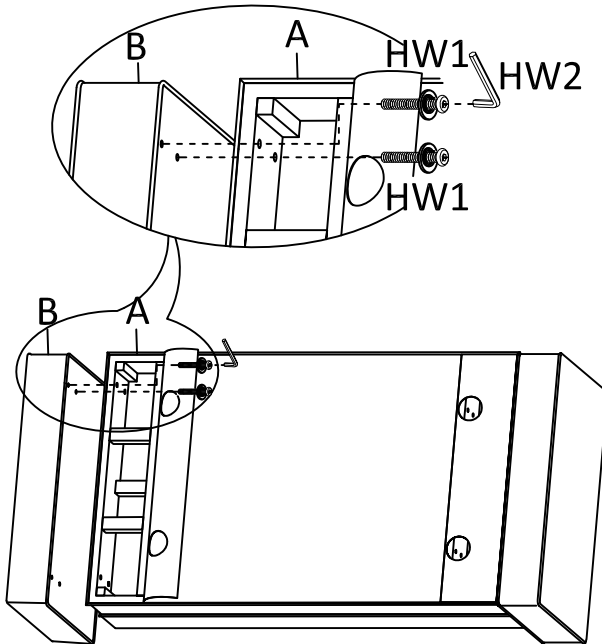

- Do not fully tighten the bolts until the product is assembled.

Step 1

From the left and right side of the small non-woven, Uncover Velcro on the both sides of Seat Cushion (A), Put 2*Armrest (B) on the two ends of the Seat Cushion (A) respectively, By using Allen Key (HW2) to lock with 8*Hex Socket Bolt (HW1), Then cover the Velcro back and press tight, as picture.

2

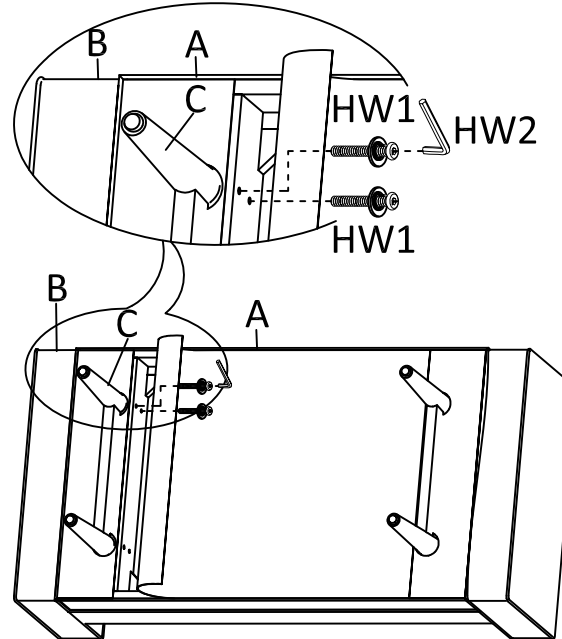

- Do not fully tighten the bolts until the product is assembled.

Step 2

For the large piece non-woven in middle, Uncover Velcro on the both sides of Seat Cushion (A), Attach 2*Frame Leg (C) in the corresponding position on the back of the Seat Cushion (A), By using Allen Key (HW2) to lock with 8*Hex Socket Bolt (HW1), Then cover the Velcro back and press tight, as picture.

3

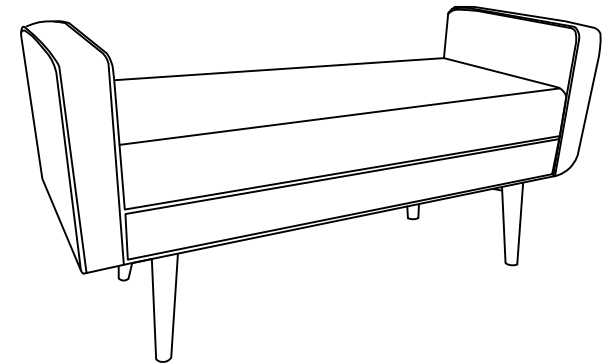

- After properly adjusting the product level for stability, then fully tighten all bolts.

Step 3

Straighten up the assembled product, Assembly is completed.