

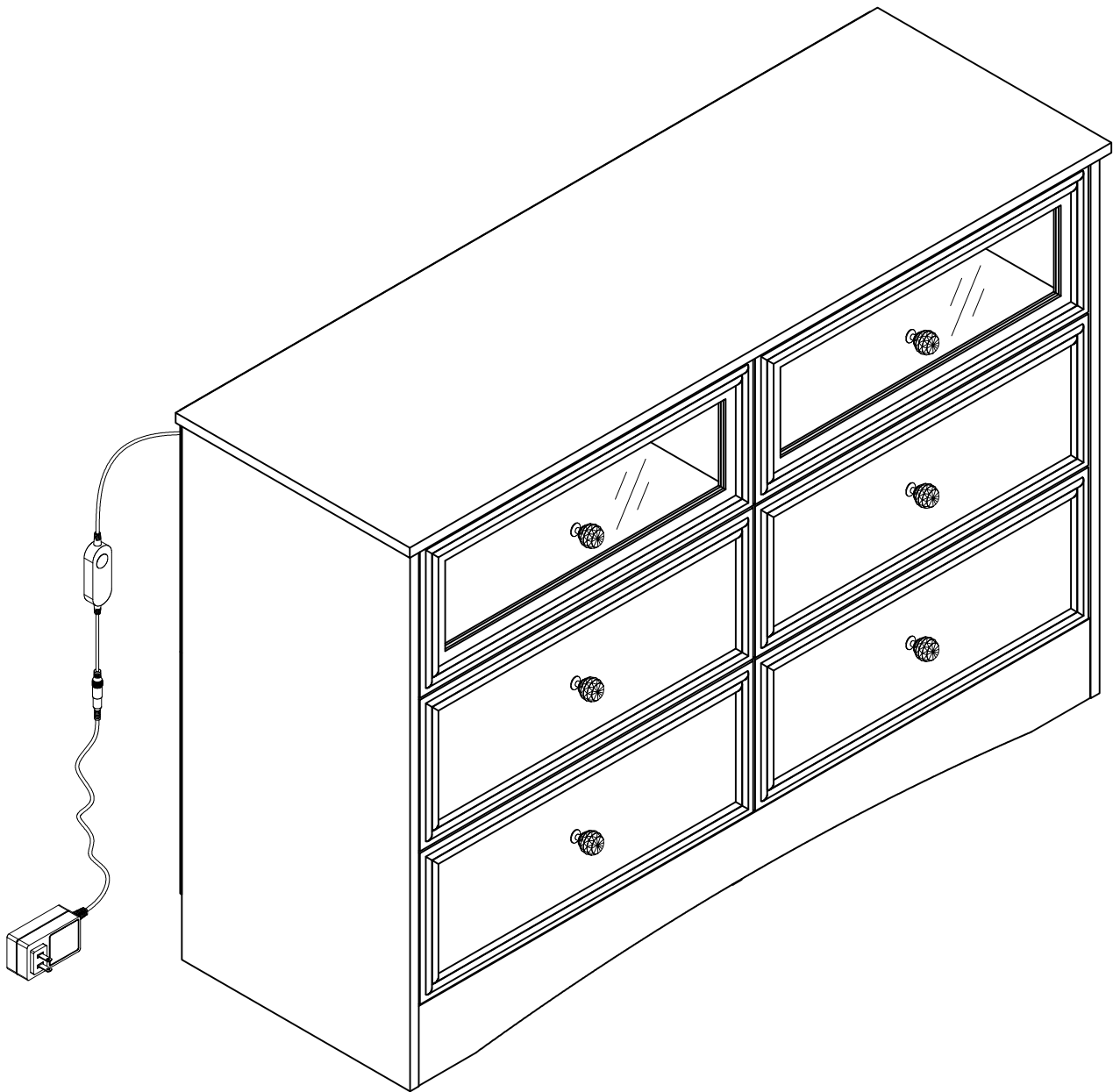

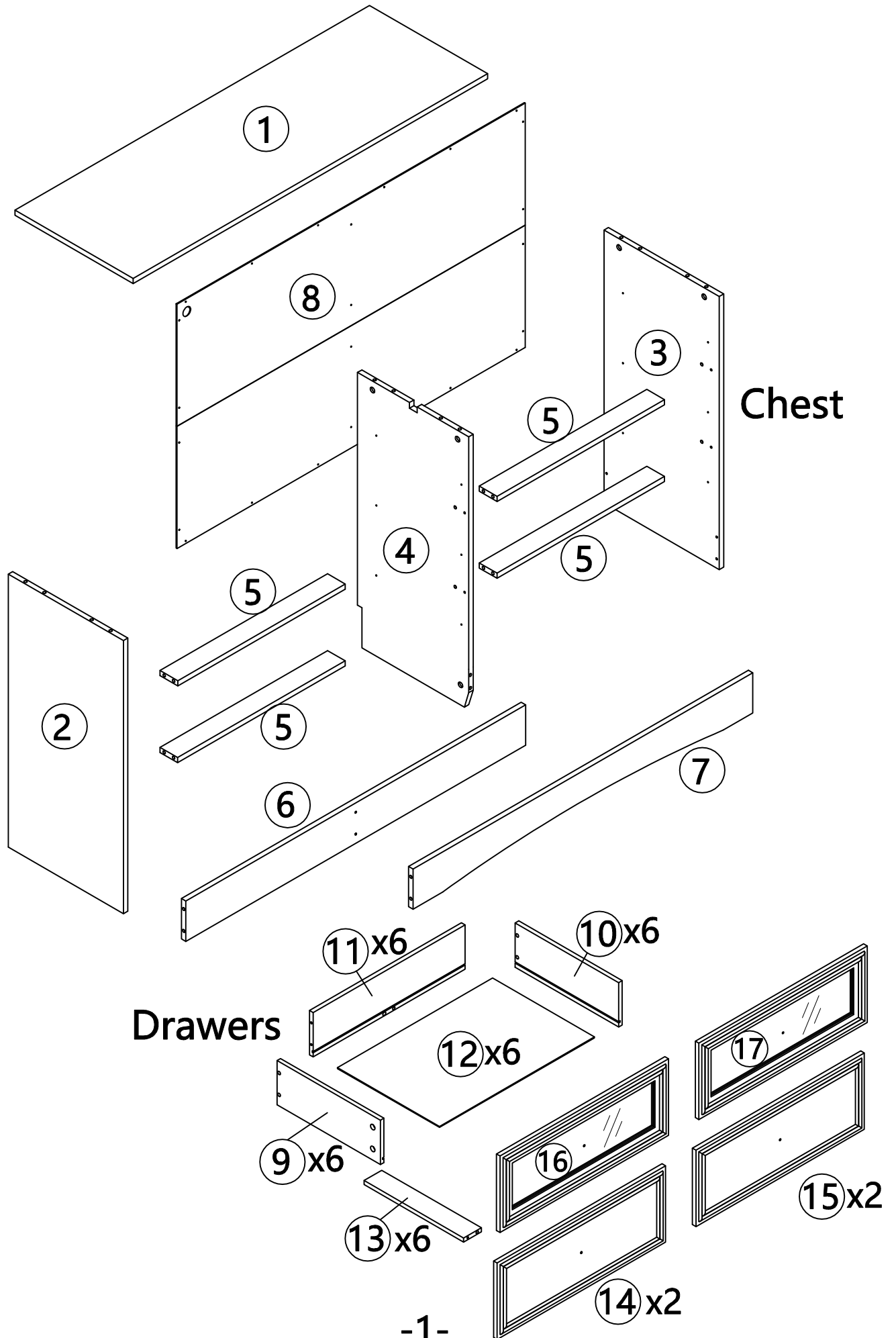





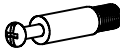

6 DRAWER DRESSER USER MANUAL



STRUCTURE FOR REFERENCE TO ASSEMBLY

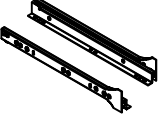
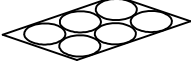
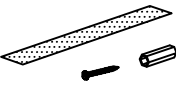

List of Parts

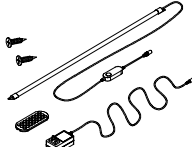
No.	Hare ware	Quantity
A		59+1
B	 Ø8x30MM	15+1
C	 Ø15x9MM	59+1
D	 Ø3.5x35MM	26
E	 Ø6x30MM	24
F		6
G	 M4x16MM	4
H	 Ø3.5x12MM	72+1
I	 Ø3.5x12MM	28+1
J	 14"	6
K		24+1
L		2
M	 M4x8MM	2
N		1

How the knock down (kd) assembly system works

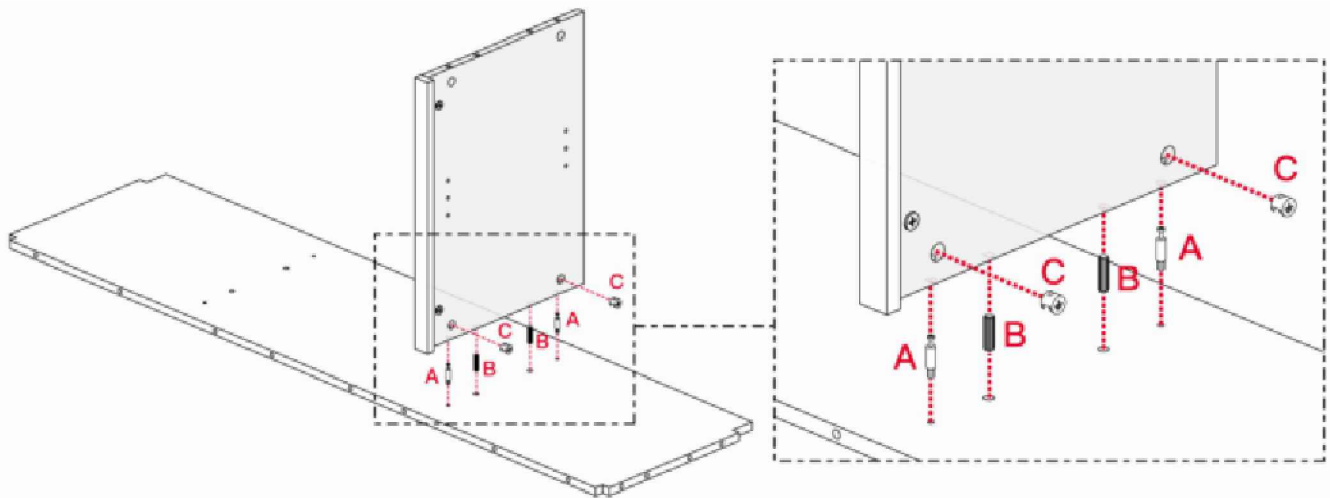

How to Install Wood Dowel

Insert the wood dowel [B] at least half way by tapping lightly with a rubber mallet, IF NECESSARY.

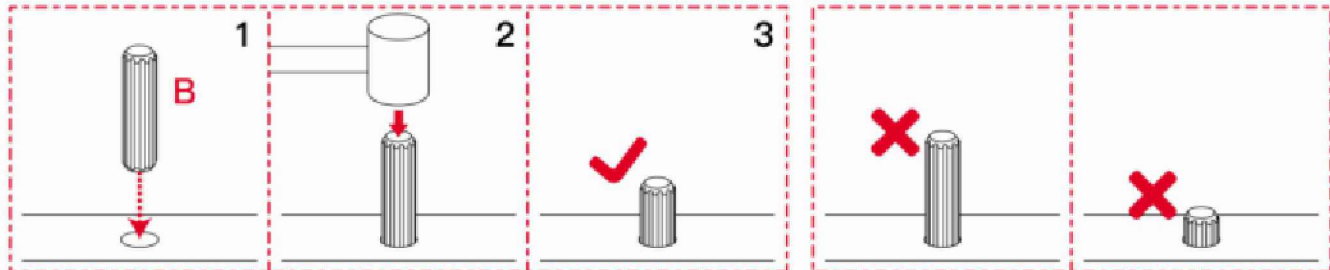

CAM LOCK SYSTEM OPERATION

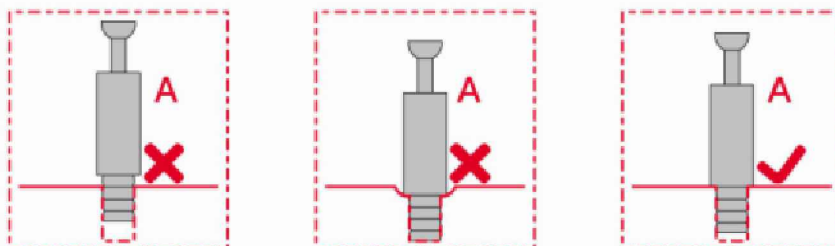

1. Screw the cam bolt [A] into the threaded insert on the panel.
2. Connect both panels together making sure cam bolt [A] goes into the pre-drilled large hole on the end of panel for cam lock [C].
3. Insert the cam lock [C] into the pre-drilled large hole on the panel. **Make sure the cross slot of cam lock [C] faces out.**
3. Rotate the cam lock [C] **clockwise** with a self-supplied phillips screwdriver to lock the cam bolt [A] in place.

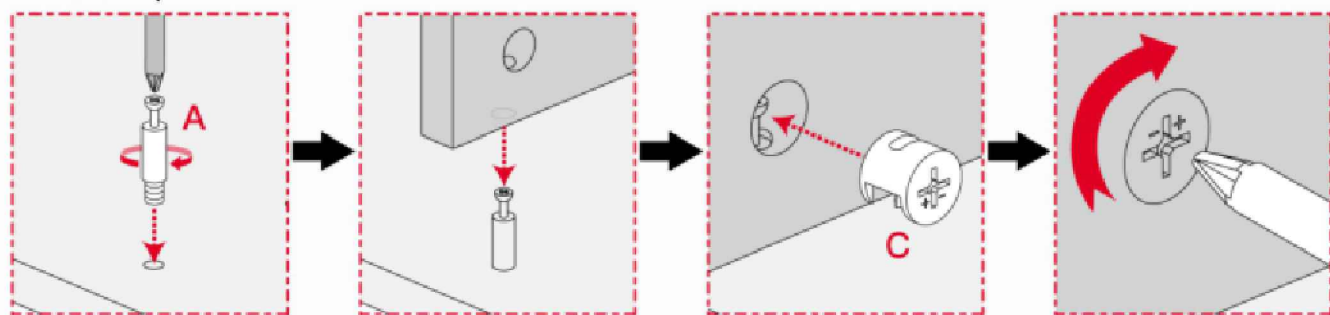

You are now ready to assemble the dresser

You are now ready to assemble the dresser

Before installation, observe each structure of the drawer dresser. The drawer dresser consists of two main parts. You will assemble the chest first, and then install six drawers. Finally, look at the finished look, and contrast list of part, imagine how to install it faster, hope this will help you.

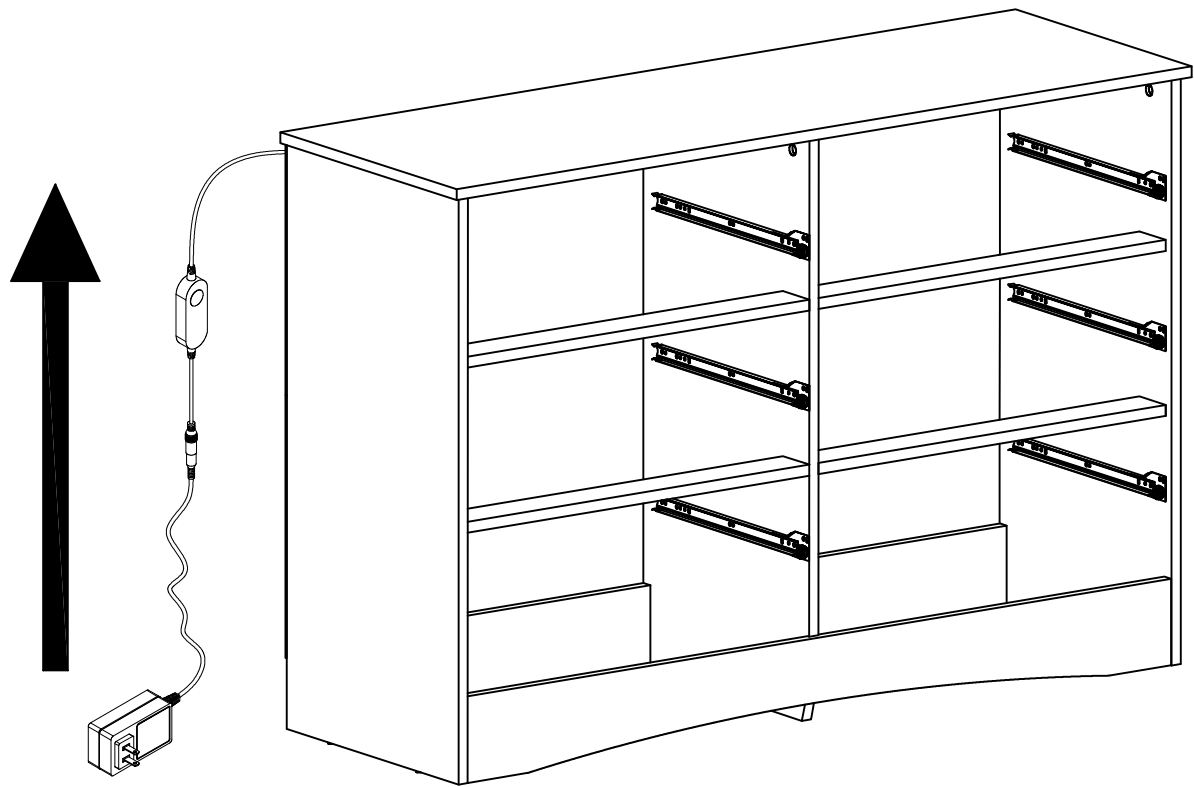

Installation steps are from bottom to top

Step 1-1

J

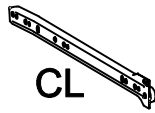

CL

3pcs

H



9pcs

When building it make sure to take note of the drawer slides is the one with a flat end.

Make sure the two large pre-drilled hole are on the upside.

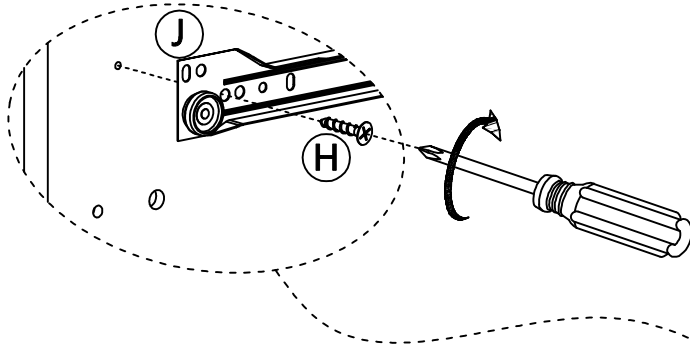

All the white wheels should be on the same side as the HORIZONTAL two adjacent small holes in the middle. And two adjacent small pre-drilled holes are for A screw and B wood stick to install reinforcement connect boards, not for H screw to install sliding rail. The white wheel is on the lower side.

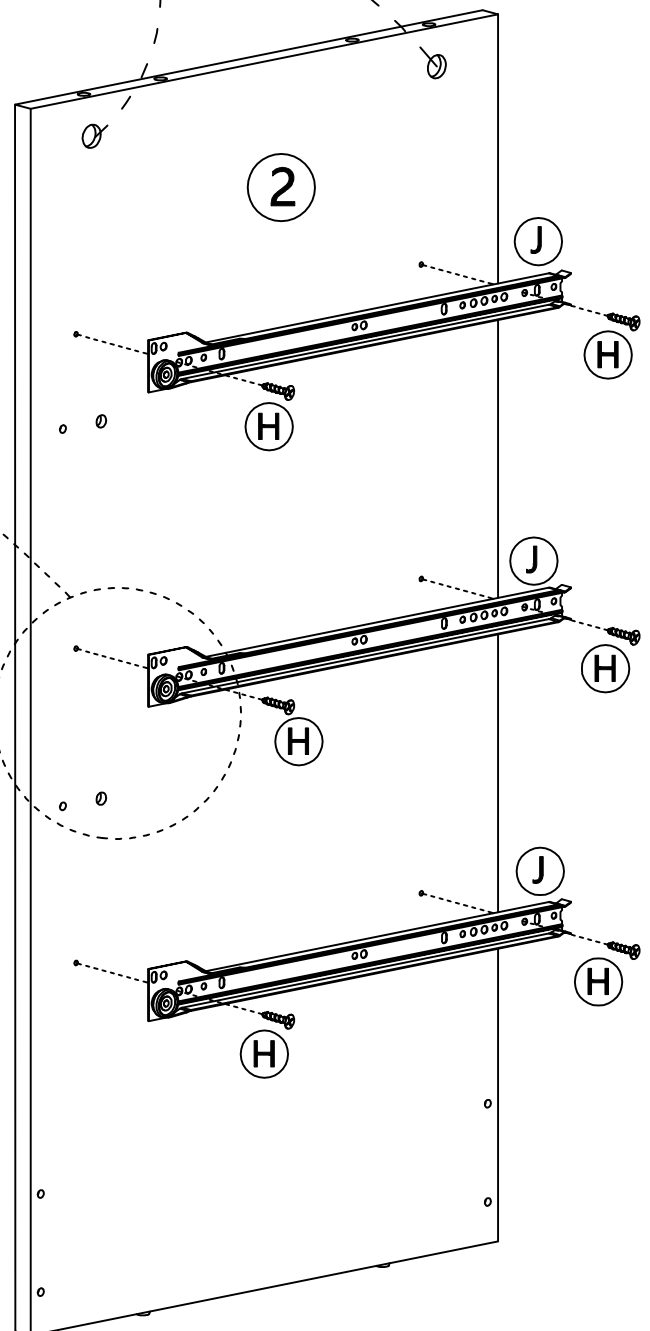

Step 1-2

NOTE:When you screw the screws, please refer to the illustration carefully to make sure that the slide screws correspond to the position.
Fix the slide first: The LOWER row of holes of the slide has two corresponding pre-drilled holes. Start with the screw in the FIRST hole in the BELOW row holes of the slide closest to drawer face.

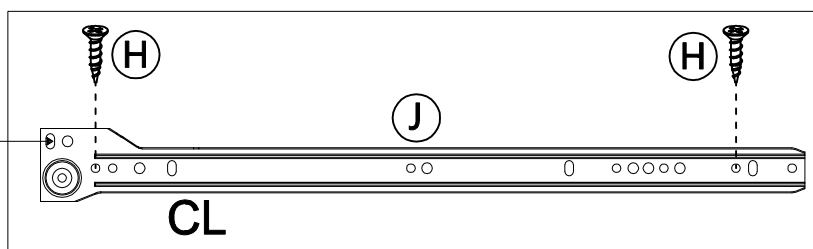

The first hole in the UPPER row holes of the slide is without the corresponding pre-drilled hole, after fix the position of the slide and then screw on.

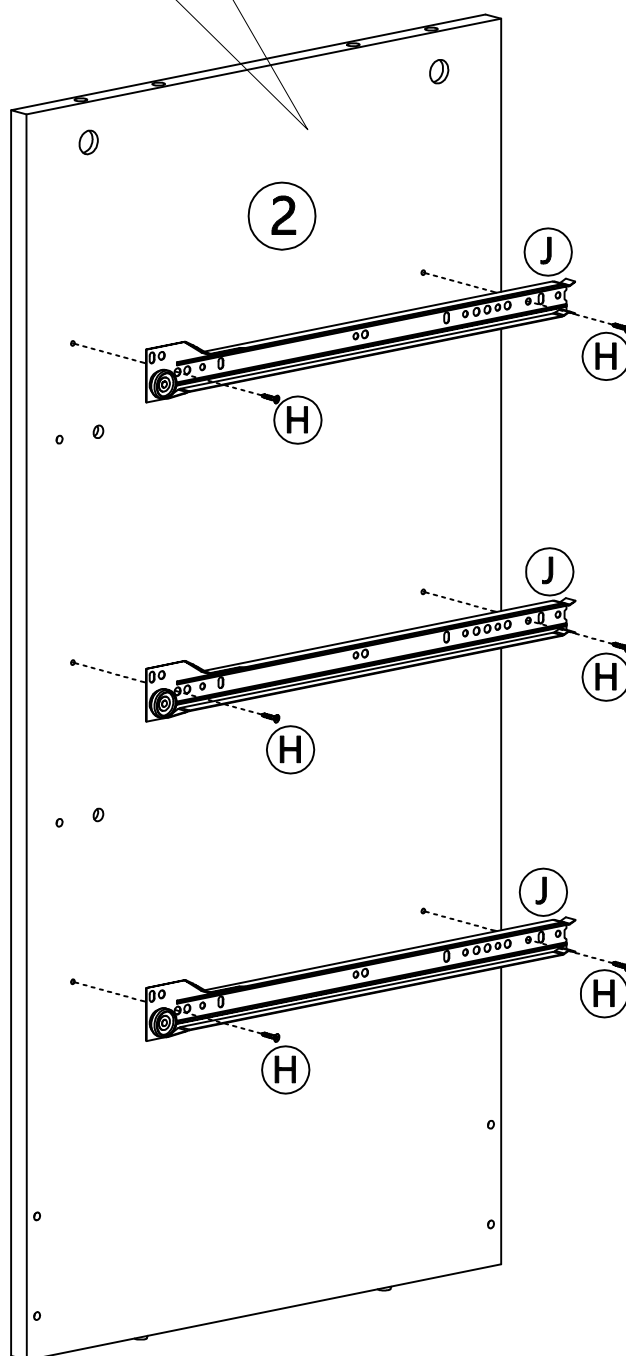

Step 1-3

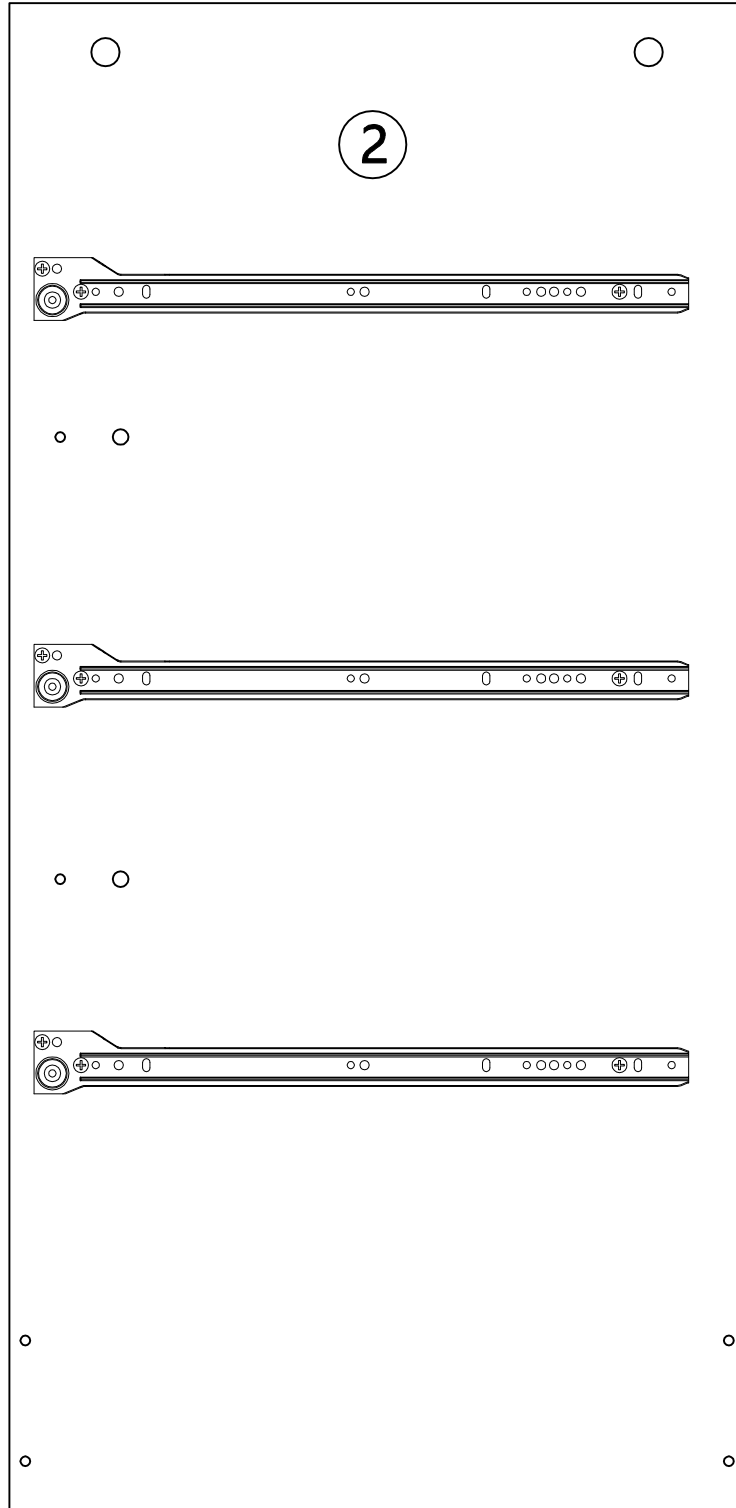

If you are confused, you can also refer to the position of this slide in the wood board.

Step 2-1

J

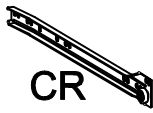

3pcs

H



9pcs

When building it make sure to take note of the drawer slides is the one with a flat end.

Make sure the two large pre-drilled hole are on the upside.

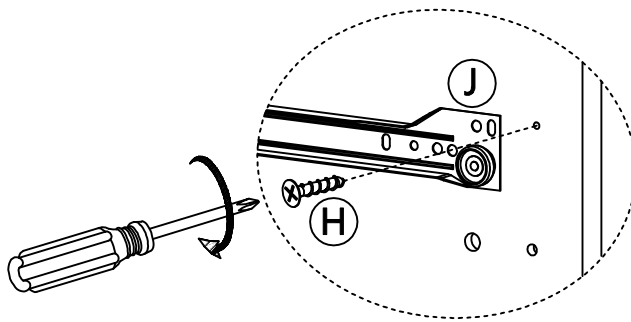

All the white wheels should be on the same side as the HORIZONTAL two adjacent small holes in the middle. And two adjacent small pre-drilled holes are for A screw and B wood stick to install reinforcement connect boards, not for H screw to install sliding rail. The white wheel is on the lower side.

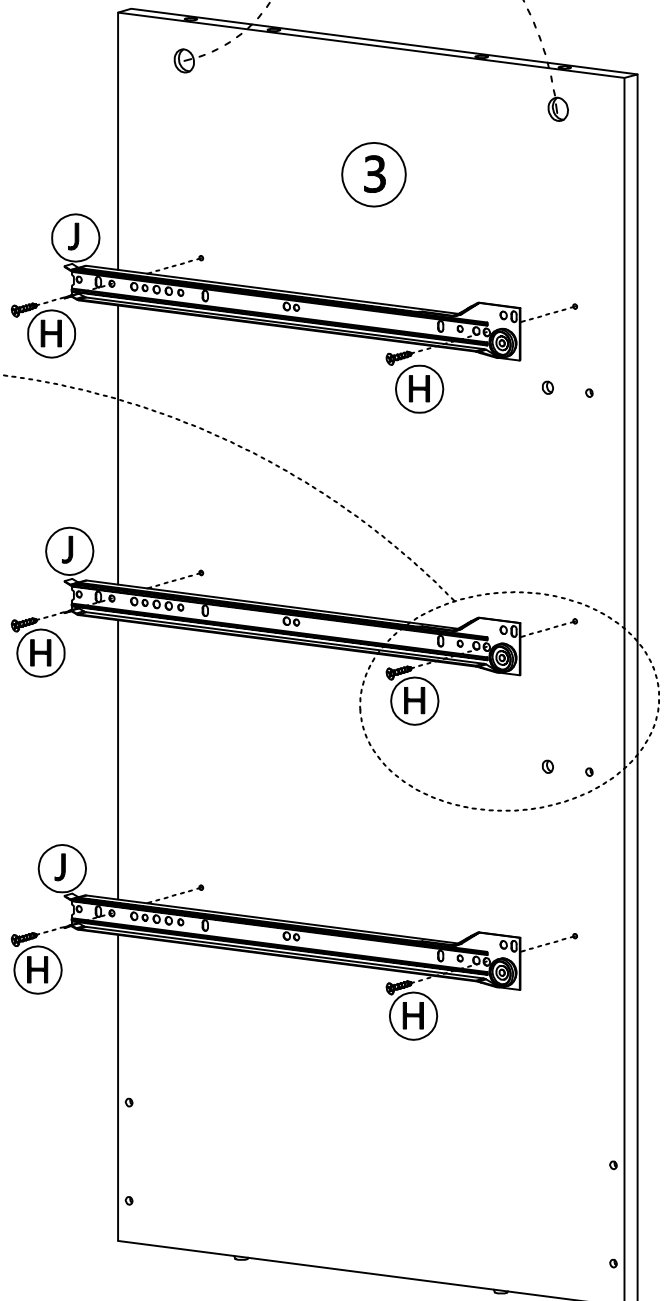

Step 2-2

NOTE:When you screw the screws, please refer to the illustration carefully to make sure that the slide screws correspond to the position.
Fix the slide first: The LOWER row of holes of the slide has two corresponding pre-drilled holes. Start with the screw in the FIRST hole in the BELOW row holes of the slide closest to drawer face.

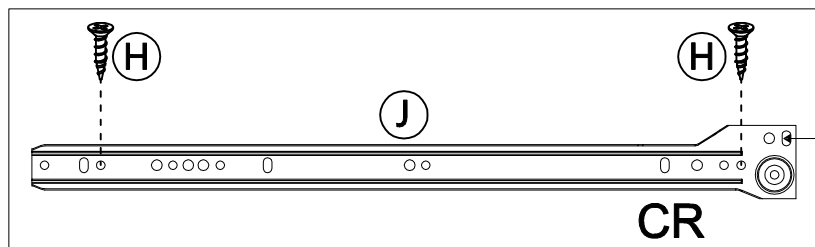

The first hole in the UPPER row holes of the slide is without the corresponding pre-drilled hole, after fix the position of the slide and then screw on.

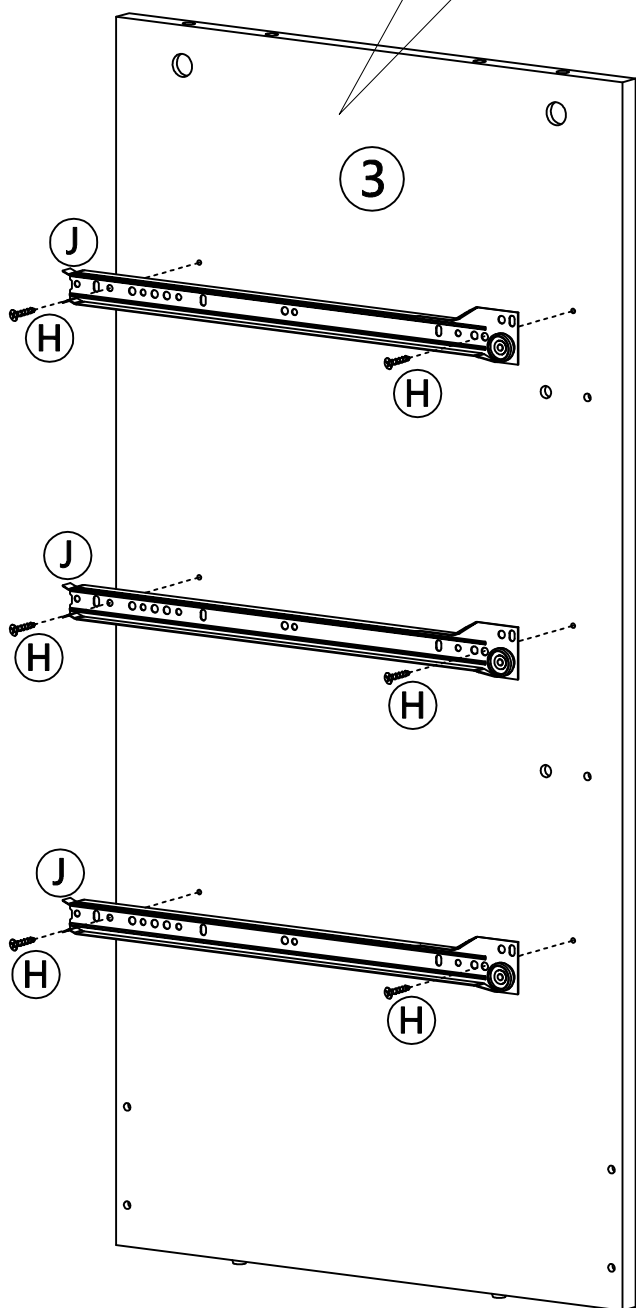

Step 2-3

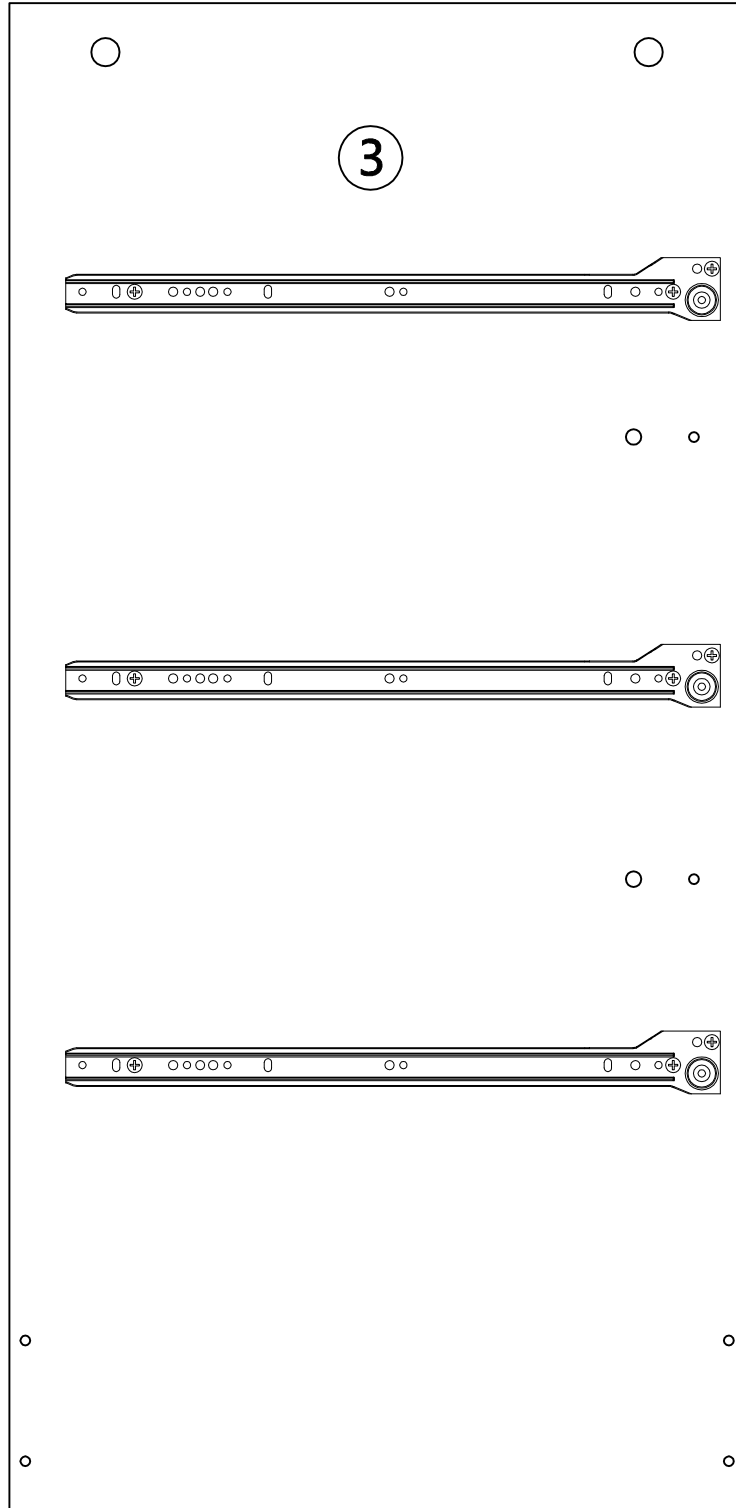

If you are confused, you can also refer to the position of this slide in the wood board.

Step 3-1

J

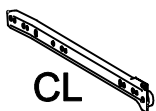

3pcs

H



9pcs

When building it make sure to take note of the drawer slides is the one with a flat end.
Fix the slide: The lower row of holes of the slide has two corresponding pre-drilled holes.
Start with the screw in the FIRST hole in the BELOW row holes of the slide closest to drawer face.

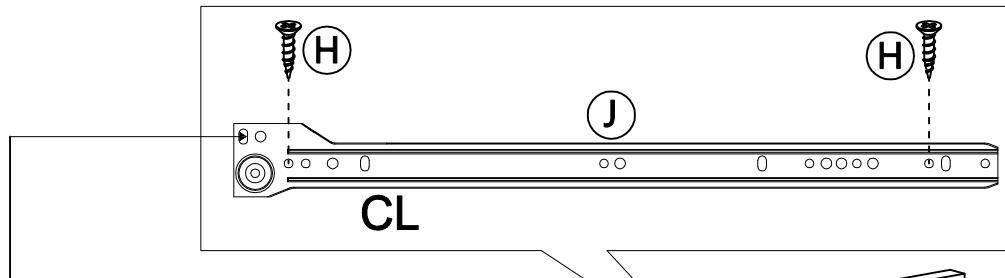

The first hole in the UPPER row holes of the slide is without the corresponding pre-drilled hole, after fix the position of the slide and then screw on.

Install three slide rails on the right side of board 4.

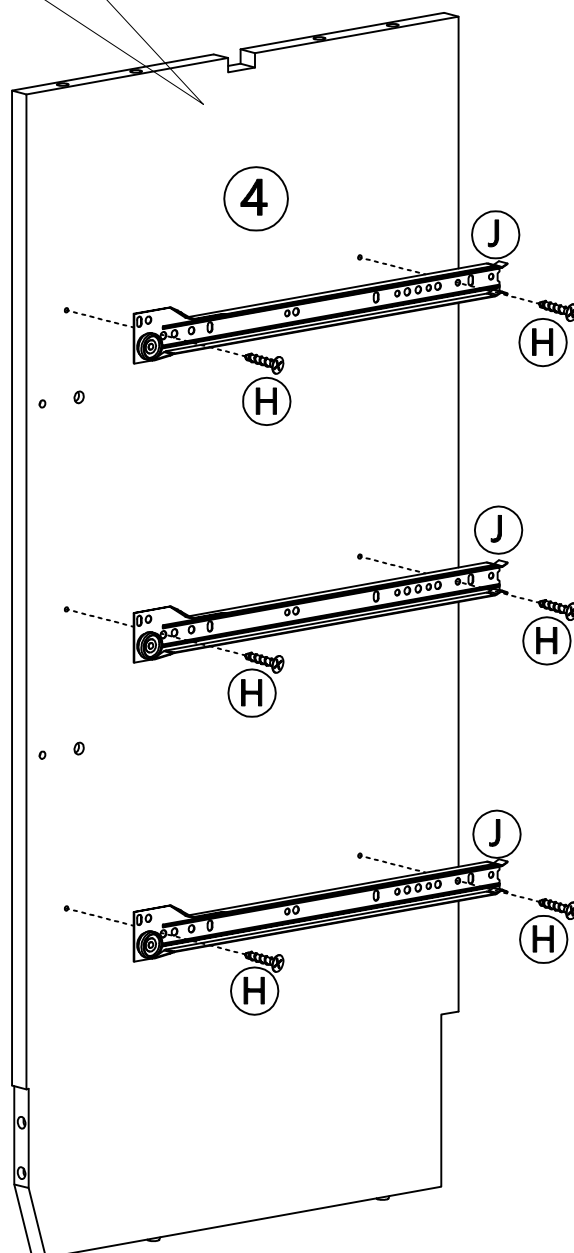

Consistent with the previous steps, all the white wheel should be on the same side as the two HORIZONTAL adjacent small holes in the middle. The white wheel is on the lower side.

Step 3-2

(J)

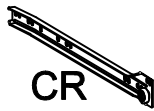

3pcs

(H)



9pcs

When building it make sure to take note of the drawer slides is the one with a flat end.
Fix the slide: The lower row of holes of the slide has two corresponding pre-drilled holes.
Start with the screw in the FIRST hole in the BELOW row holes of the slide closest to drawer face.

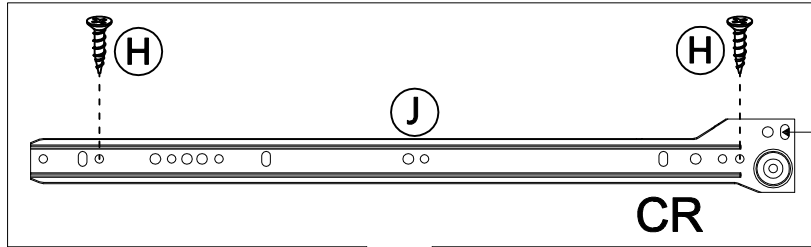

The first hole in the UPPER row holes of the slide is without the corresponding pre-drilled hole, after fix the position of the slide and then screw on.

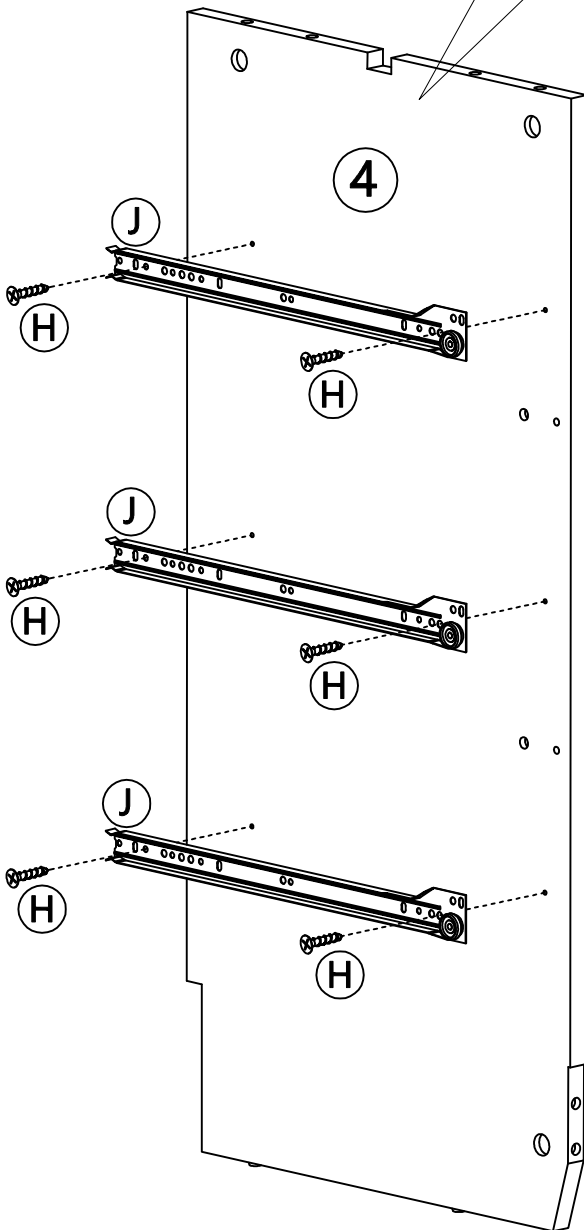

Install three slide rails on the left side of board 4.

Consistent with the previous steps, all the white wheel should be on the same side as the two HORIZONTAL adjacent small holes in the middle. The white wheel is on the lower side.

Step 3-3

Right side of the board #4

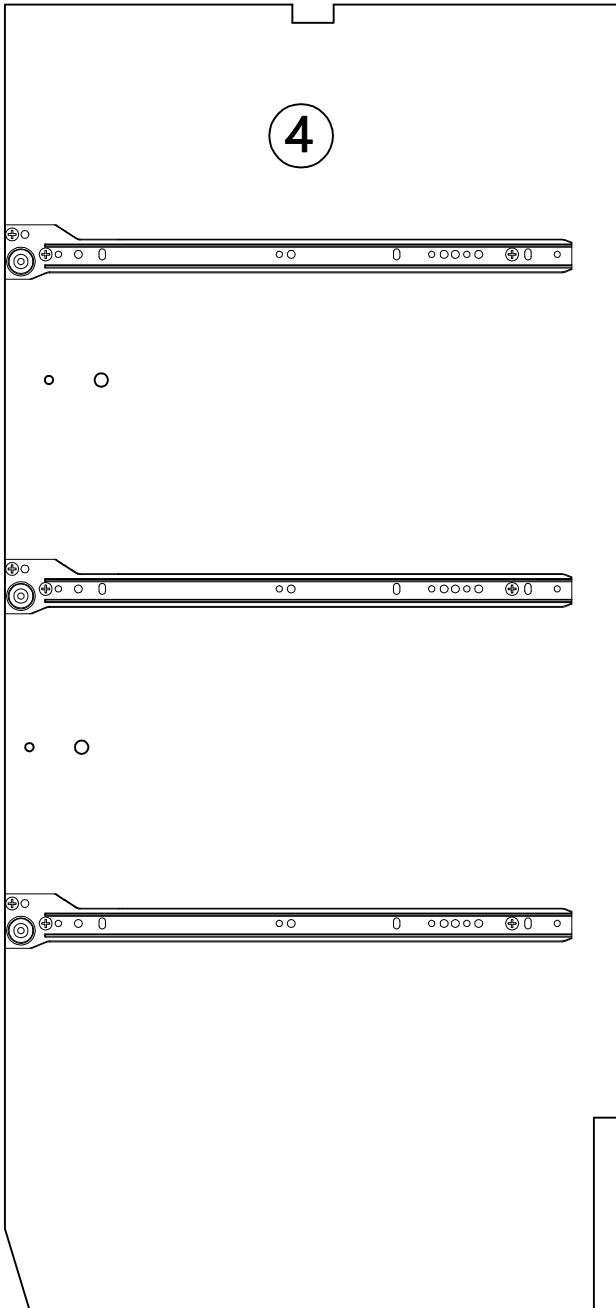

Left side of the board #4

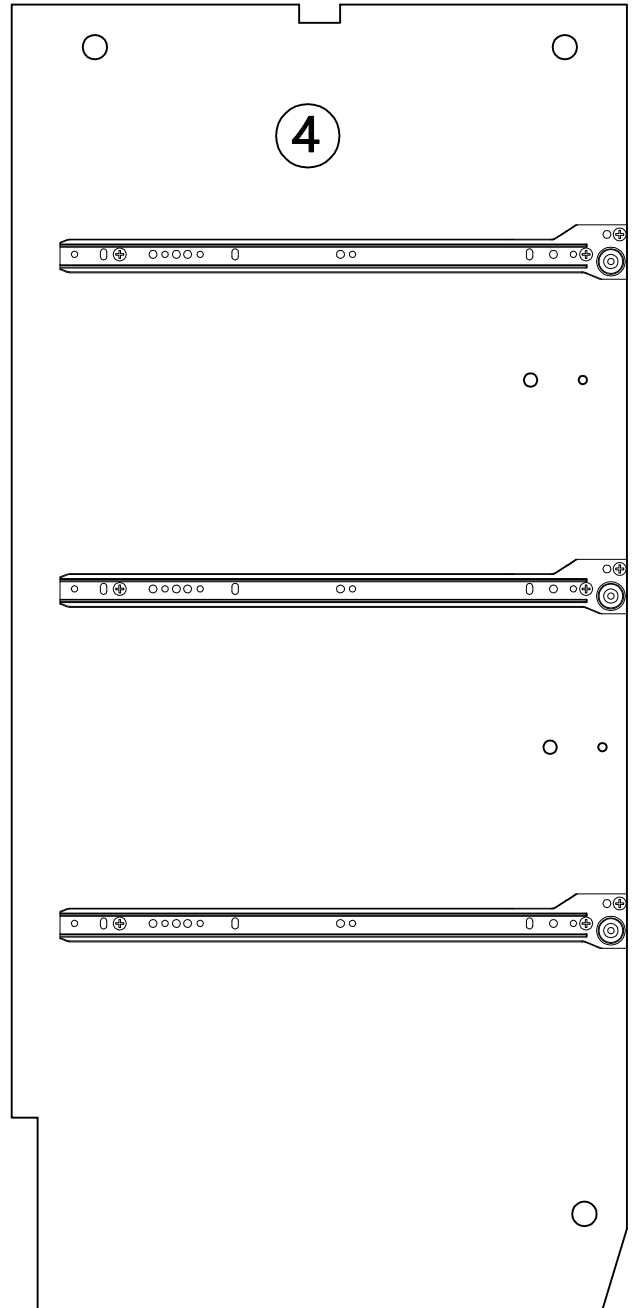

If you are confused, you can also refer to the position of this slide in the wood board.

Step 4

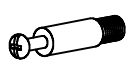
(A)  1pcs

(B)  1pcs

(C)  1pcs

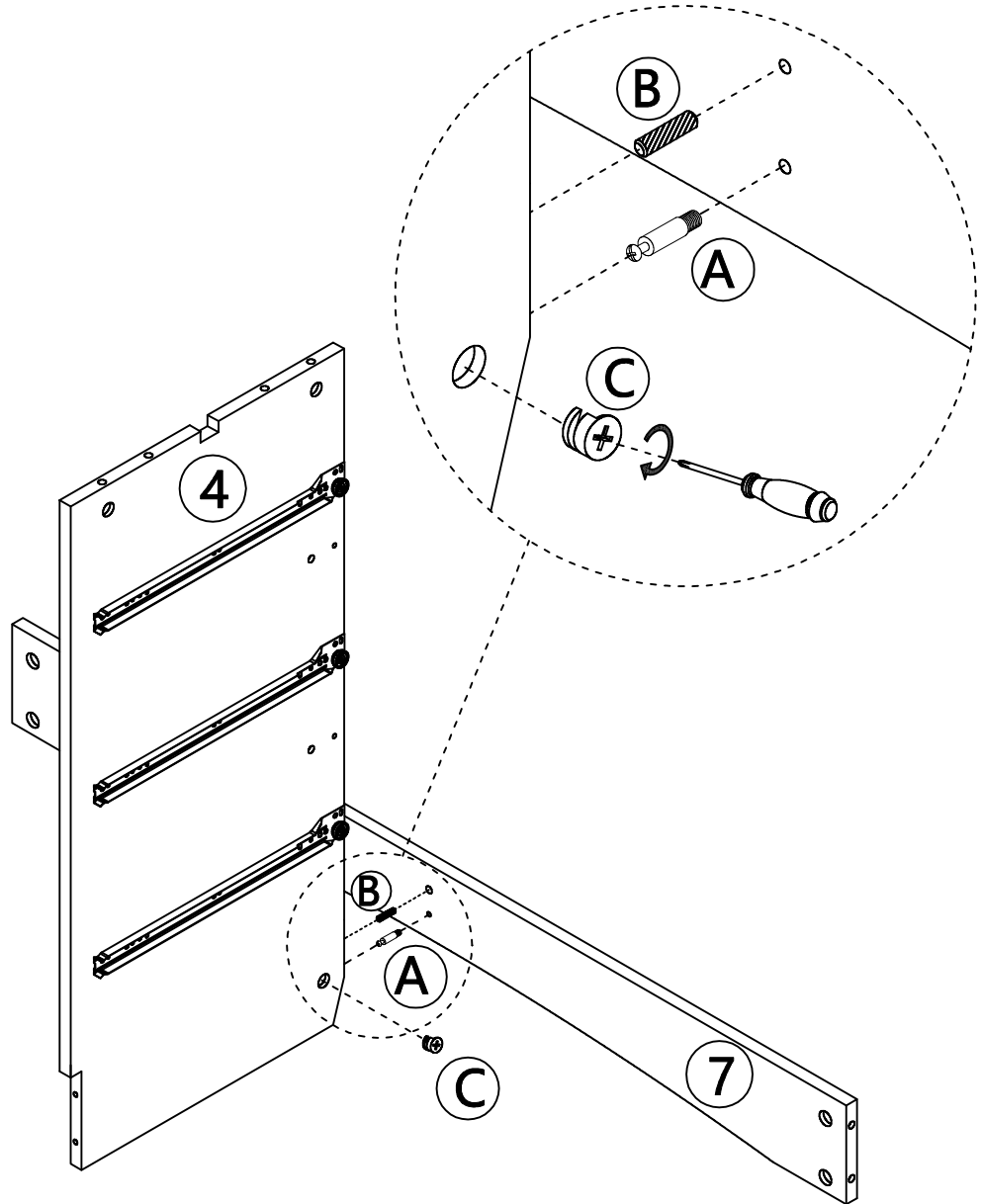

Step 5

ⓓ



2pcs

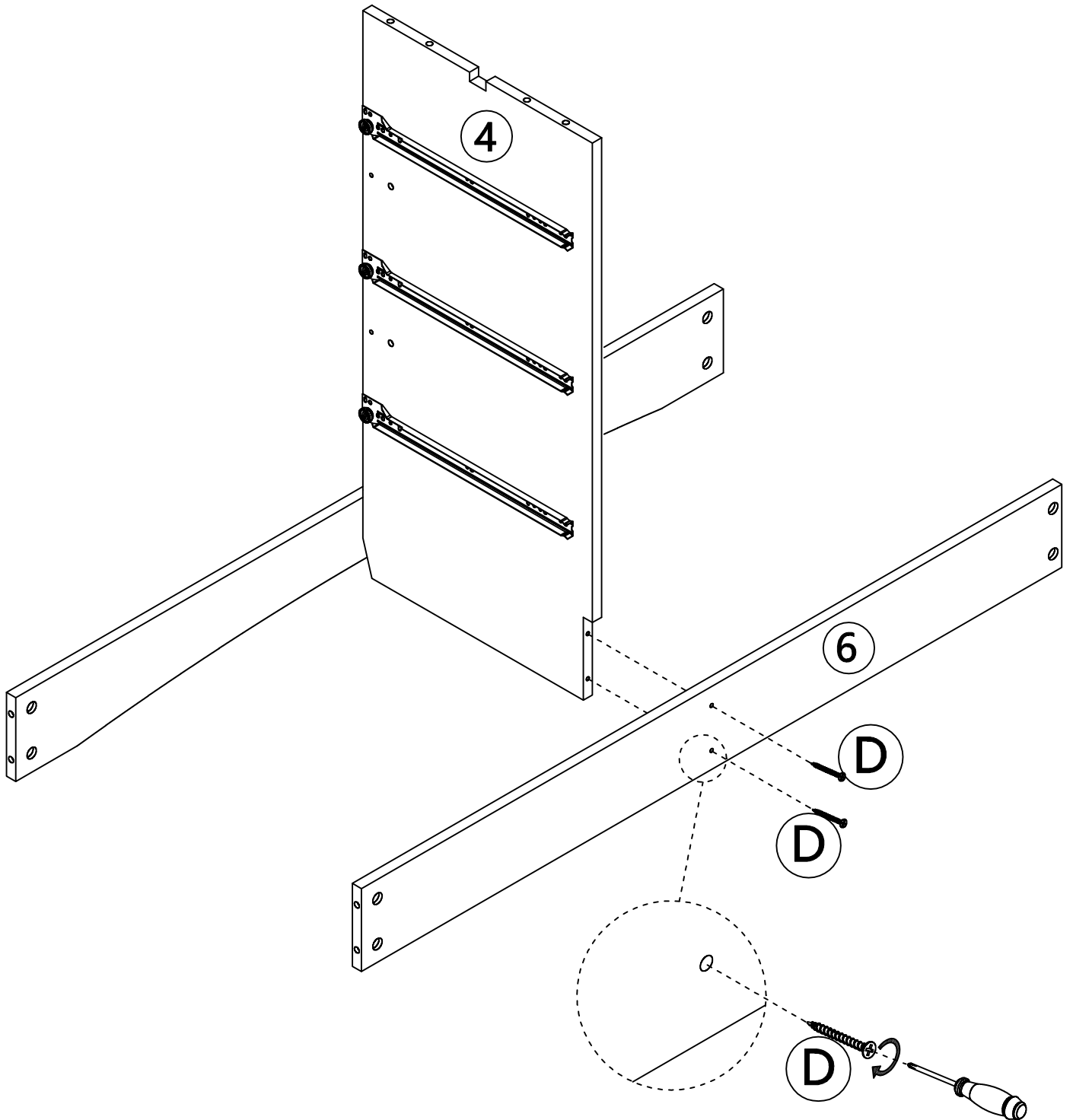

Step 6

A  8pcs

B  4pcs

C  8pcs

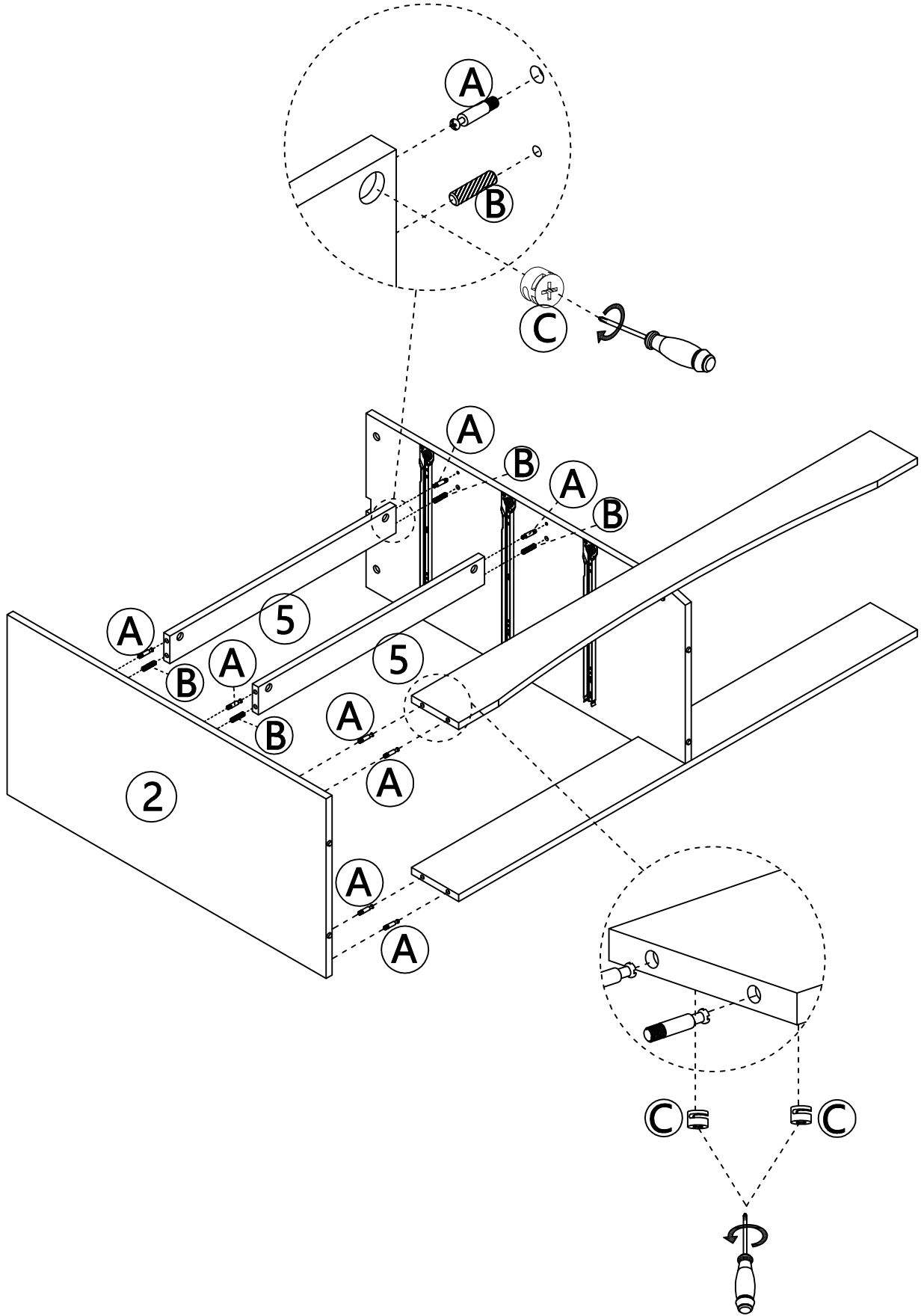

Step 7

A  8pcs

B  4pcs

C  8pcs

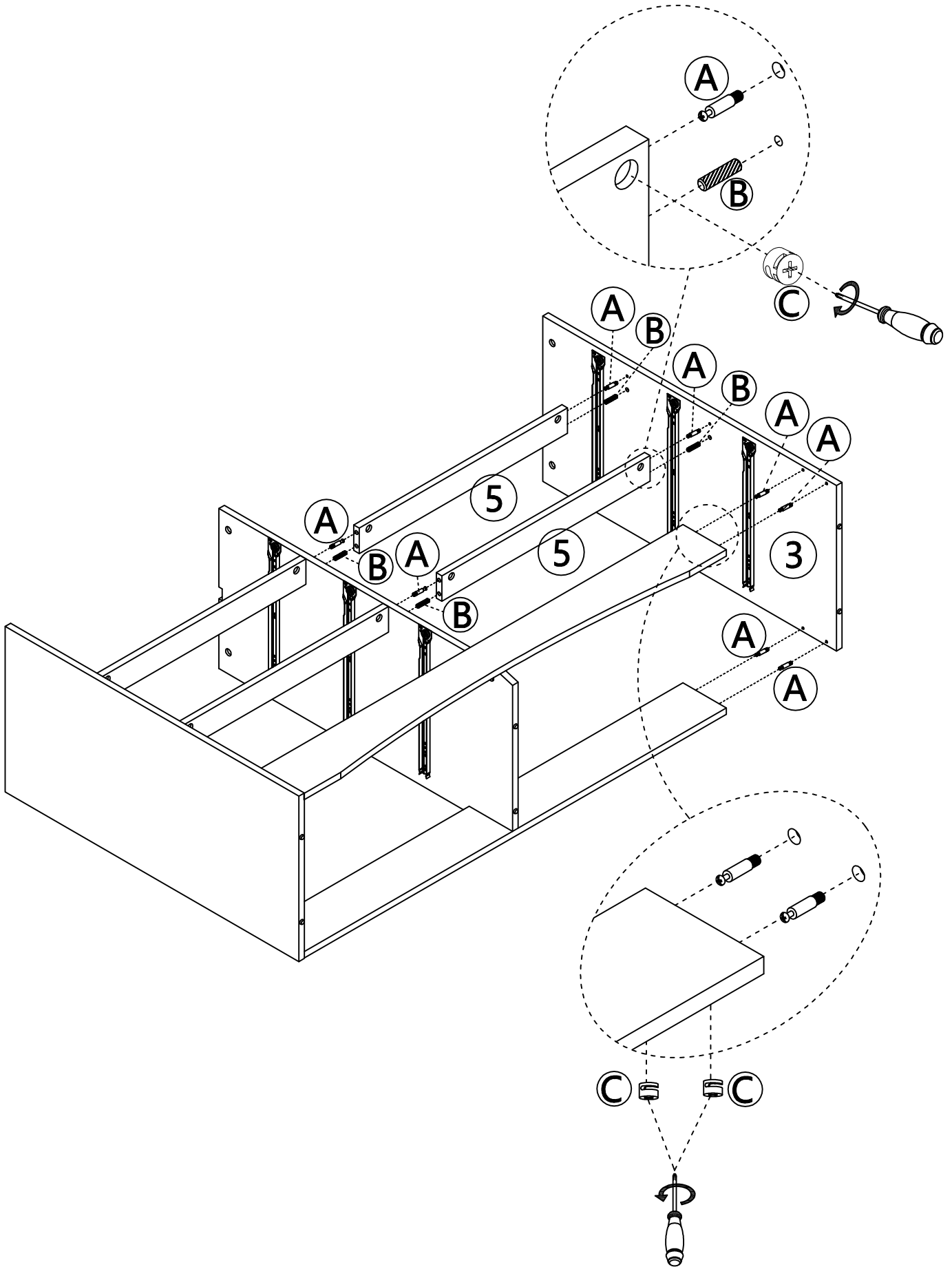

Step 8

(A)  6pcs

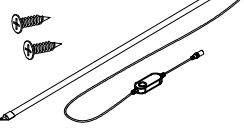
(N)  1pcs

- Screw (A) to (1) as below shown
- Install the light (N) to the board (1): 1x light & 2x screws

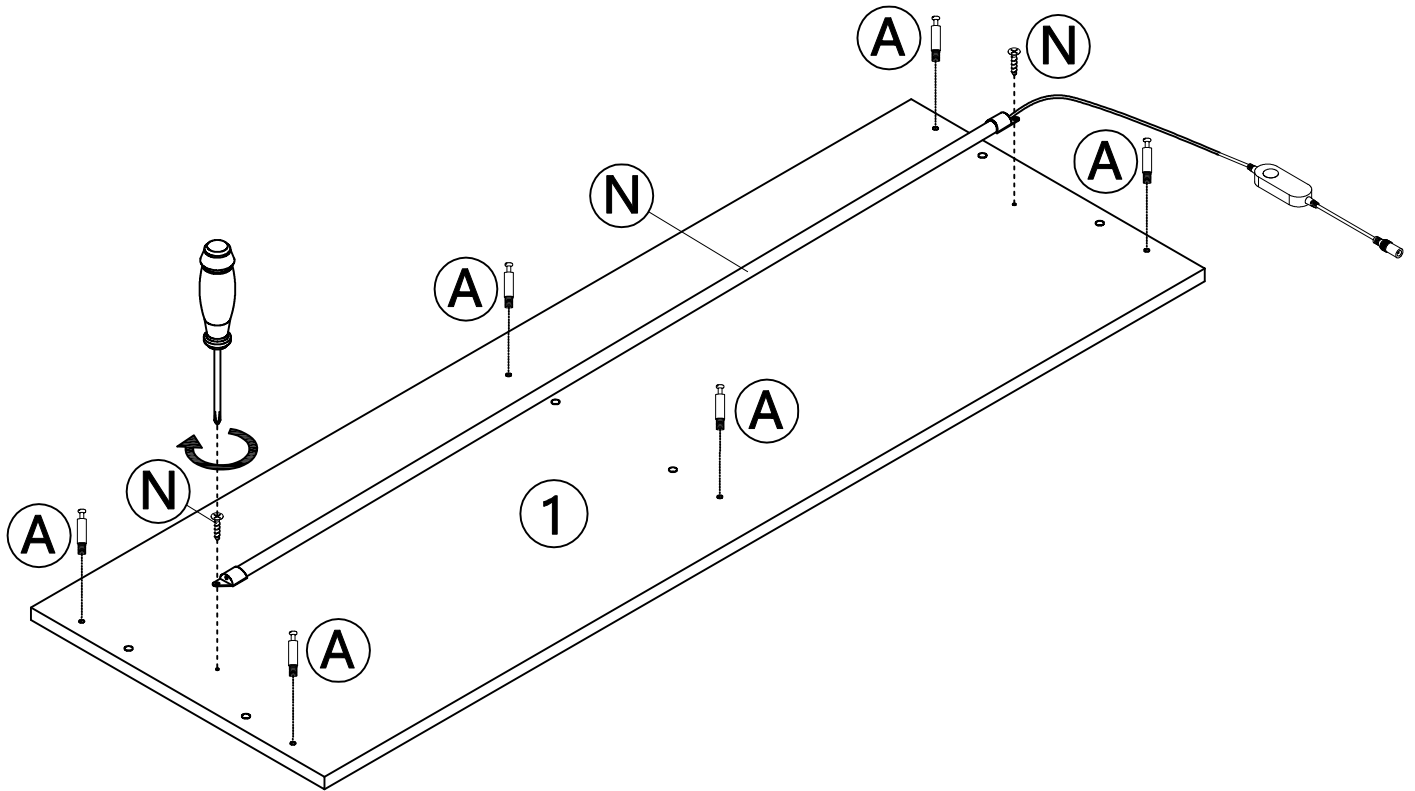
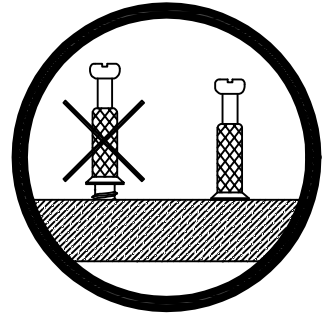

Step 9

B  6pcs

C  6pcs

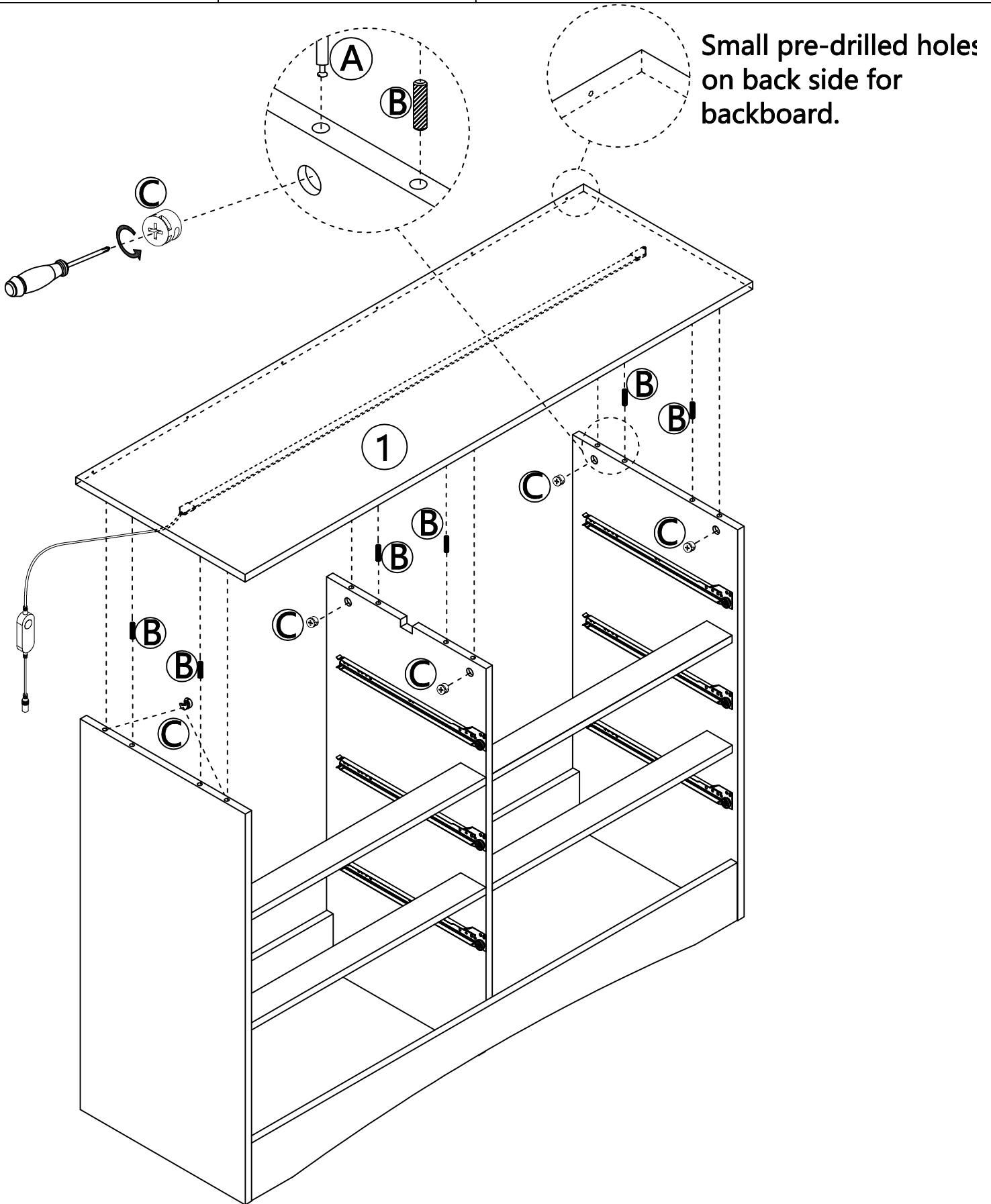

When assembling ① board. Insert B sticks in ②③④ board first, then align all the pre-drilled holes and put them together gently. Finally use the C nut to tighten with A.

Step 10

Ⓛ



28pcs

Ⓛ



2pcs

Ⓝ

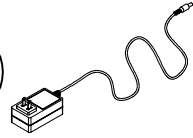

1pcs

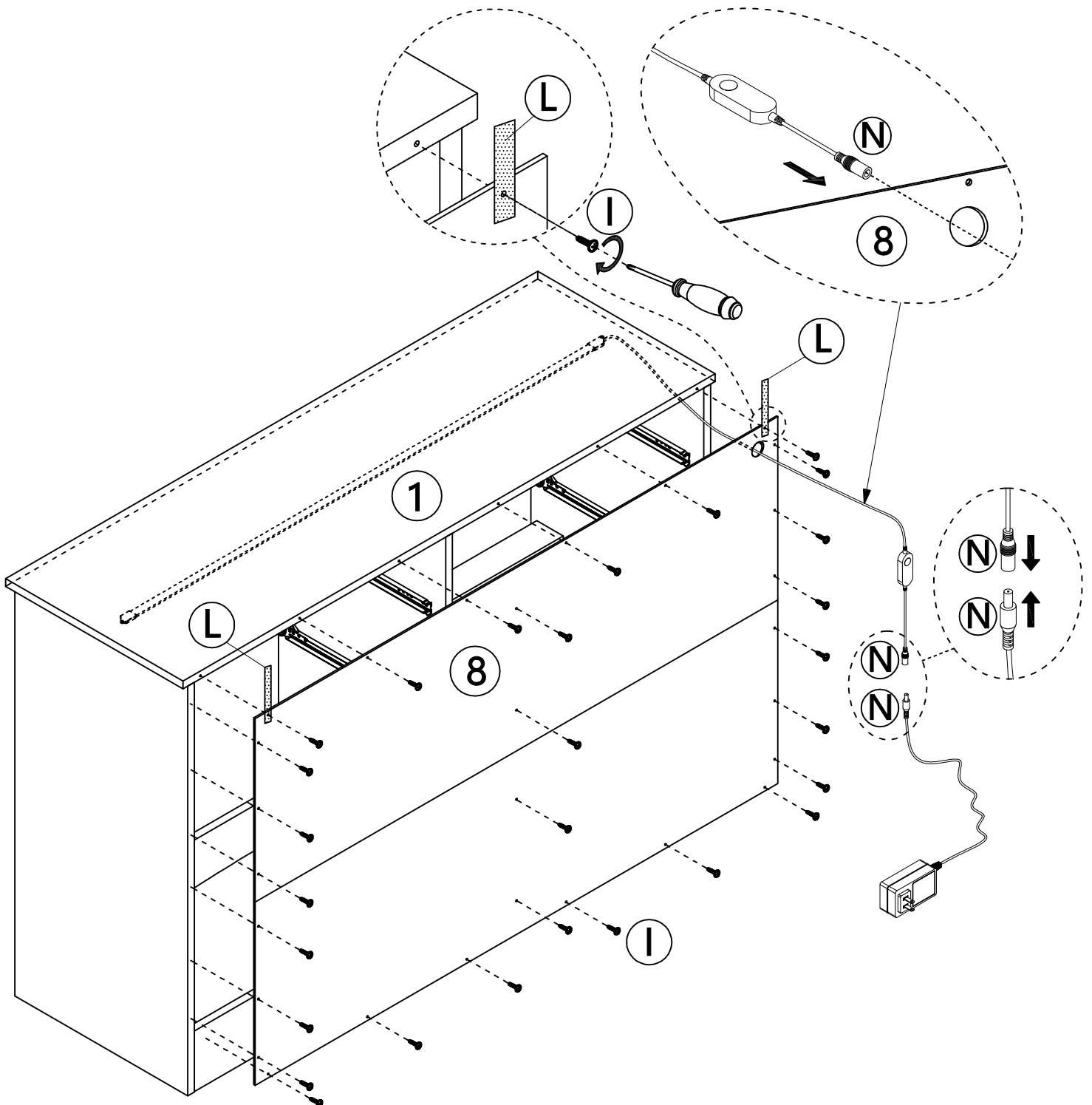

WARM TIPS : It is recommended to attach the back panel ⑧ at the top panel ① first. Please remember not to fully tighten all the screws (Ⓛ) until all of them are in correct position.

Only the top of the board has pre-drilled holes, other backboards without pre-drilled holes, just screw directly into it.

Step 11

A  6pcs

C  6pcs

D  24pcs

E  6pcs

The long groove is used to install the bottom plate, make sure to take note of installing the grooves of these boards on the same side.

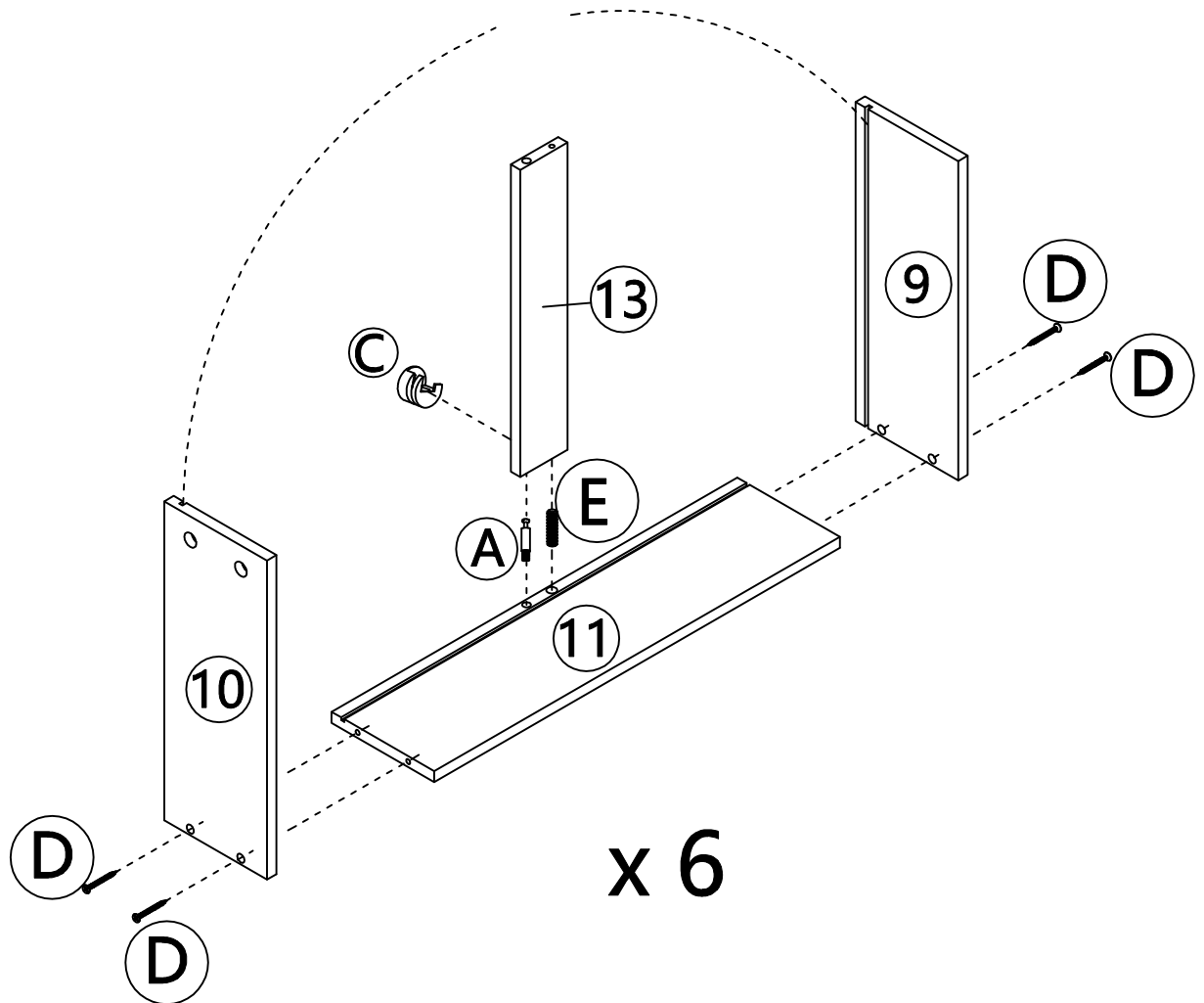

Start assembling the six drawers.

Step 12

A  15pcs

C  15pcs

E  9pcs

Note that the drawer 14/16 and drawer 15/17 is different, #14/16 board is put on the LEFT, #15/17 board is put on the RIGHT. If you put the wrong location, the drawer can not be well put in.

K  12pcs

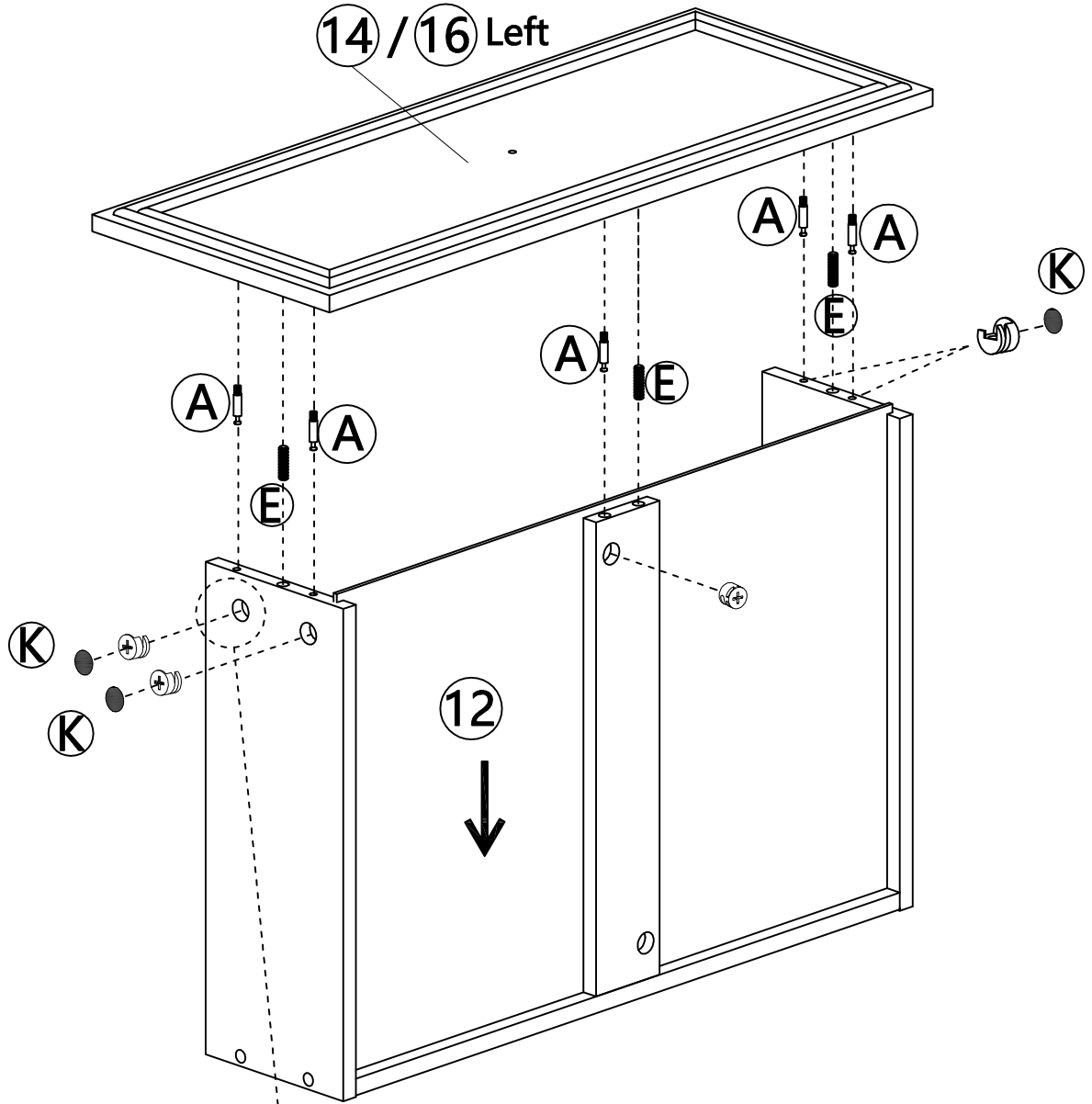

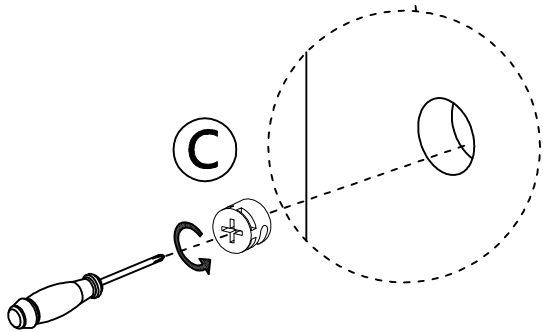

x 3



Place bottom wood panel to along the slot of ⑨ ⑩ first, and assemble drawer plank.

Step 13

A  15pcs

C  15pcs

E  9pcs

Note that the drawer 14/16 and drawer 15/17 is different, #14/16 board is put on the LEFT, #15/17 board is put on the RIGHT. If you put the wrong location, the drawer can not be well put in.

K  12pcs

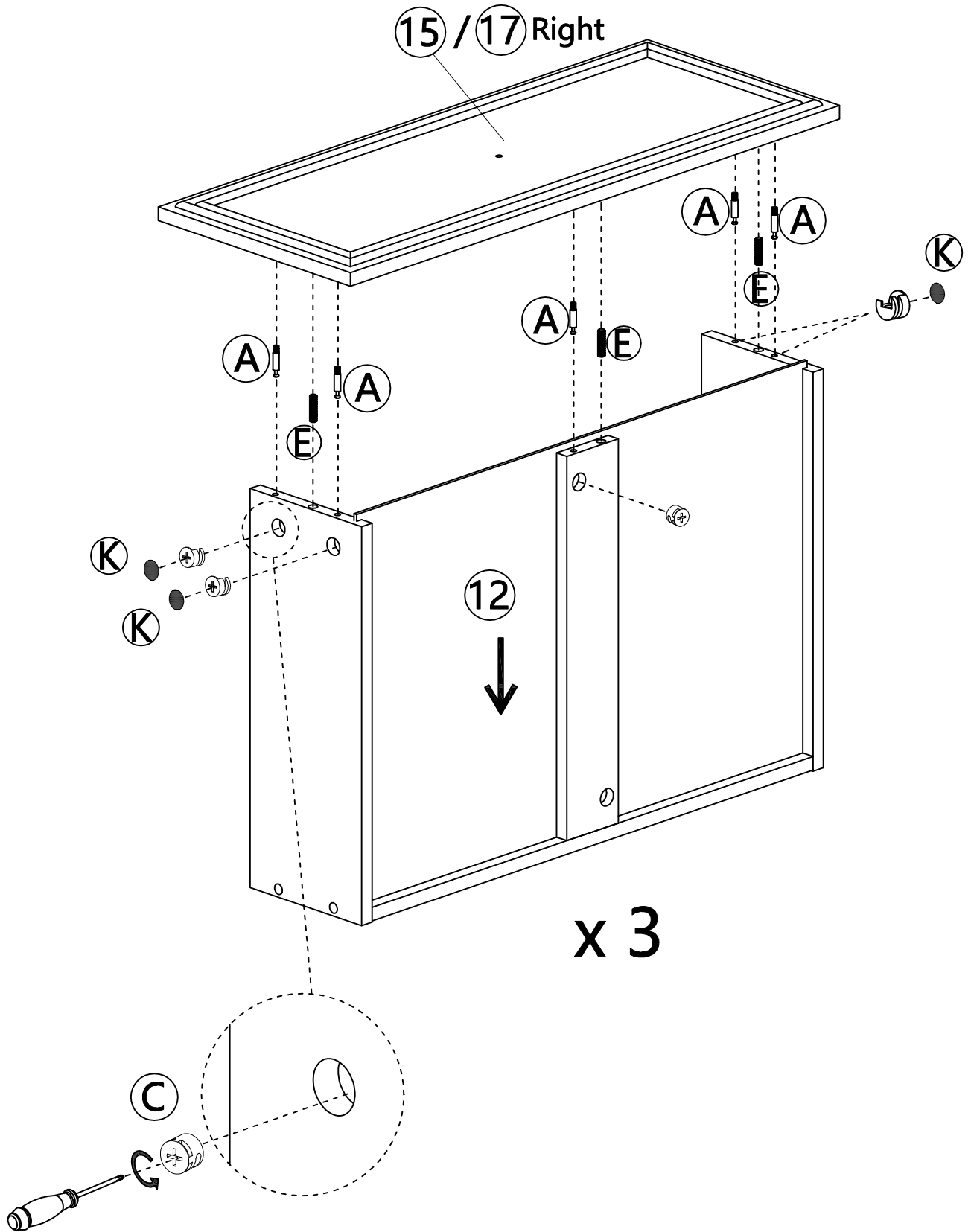

Step 14

F  6pcs

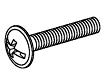
G  4pcs

M  2pcs

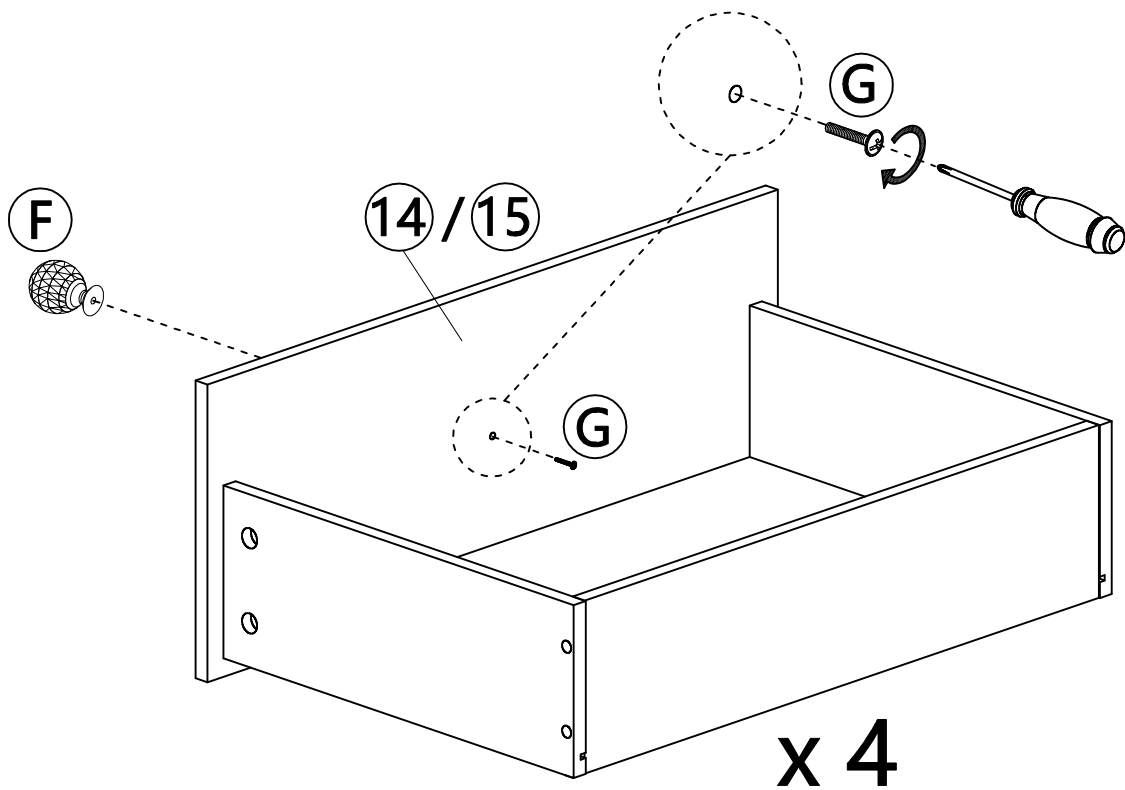
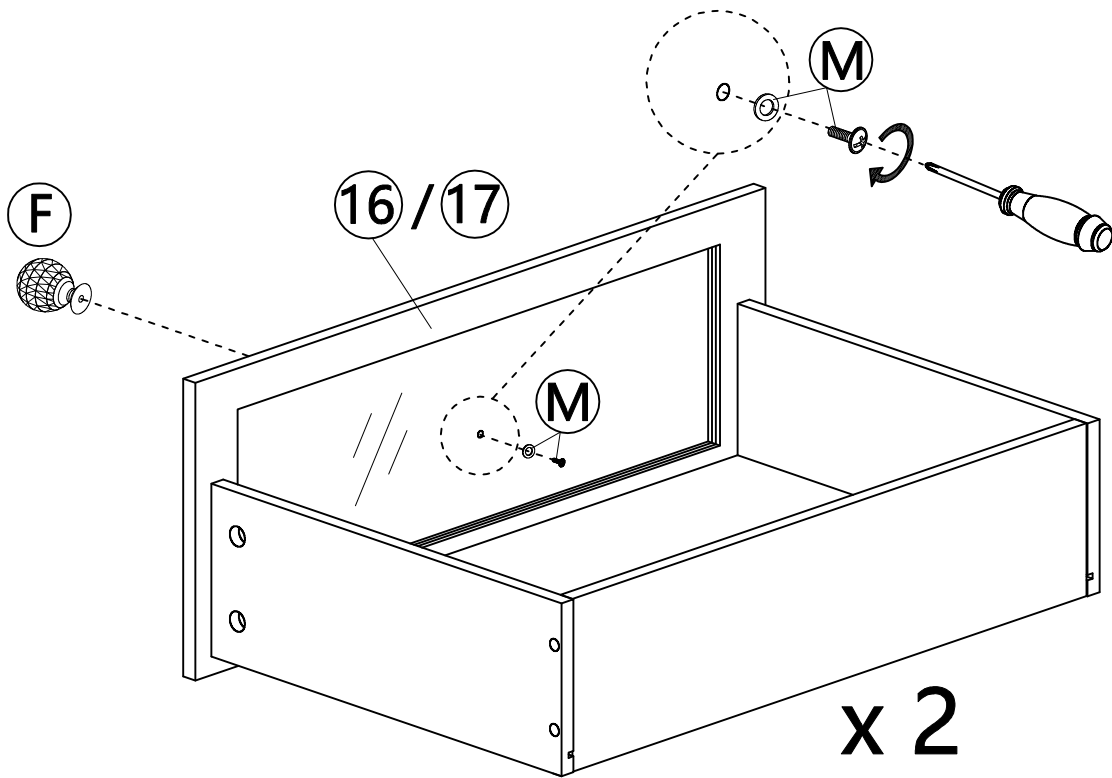

Insert screw G&M first, then align the pre-drilled holes of the pull, and tighten the screws.

Step 15

(H)



36pcs

(J)

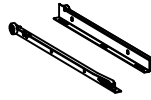

6pcs

-Install the drawer slides (J) on the drawer side panels (9) & (10) as below shown.

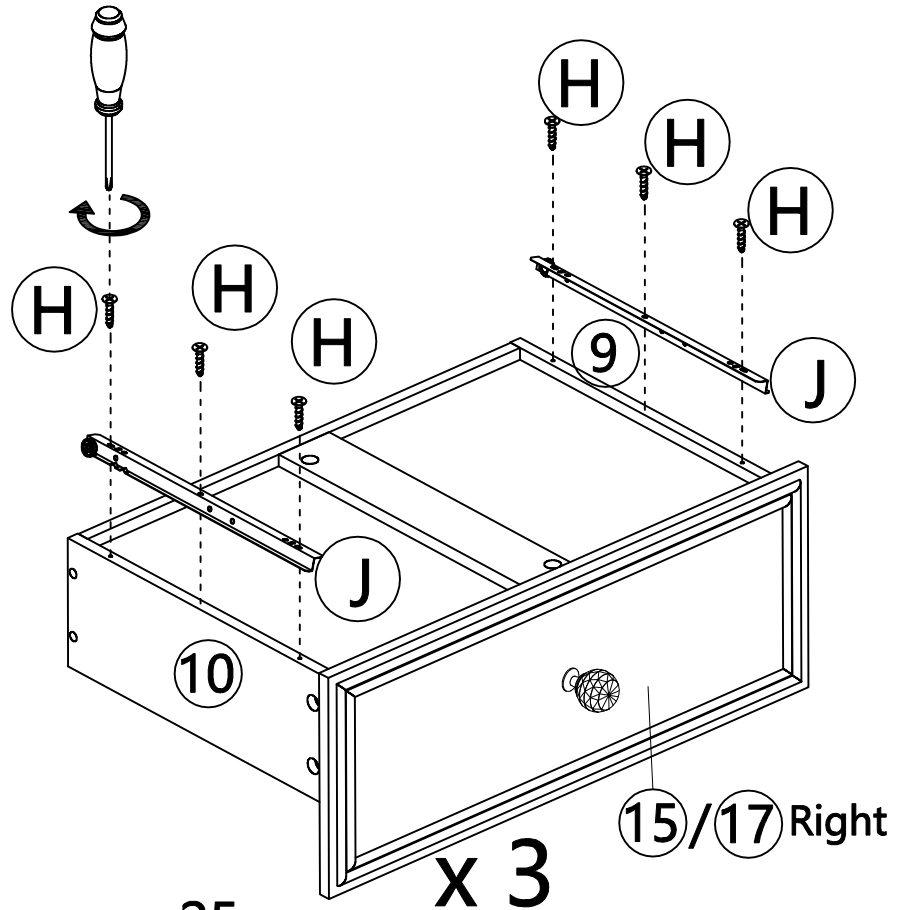
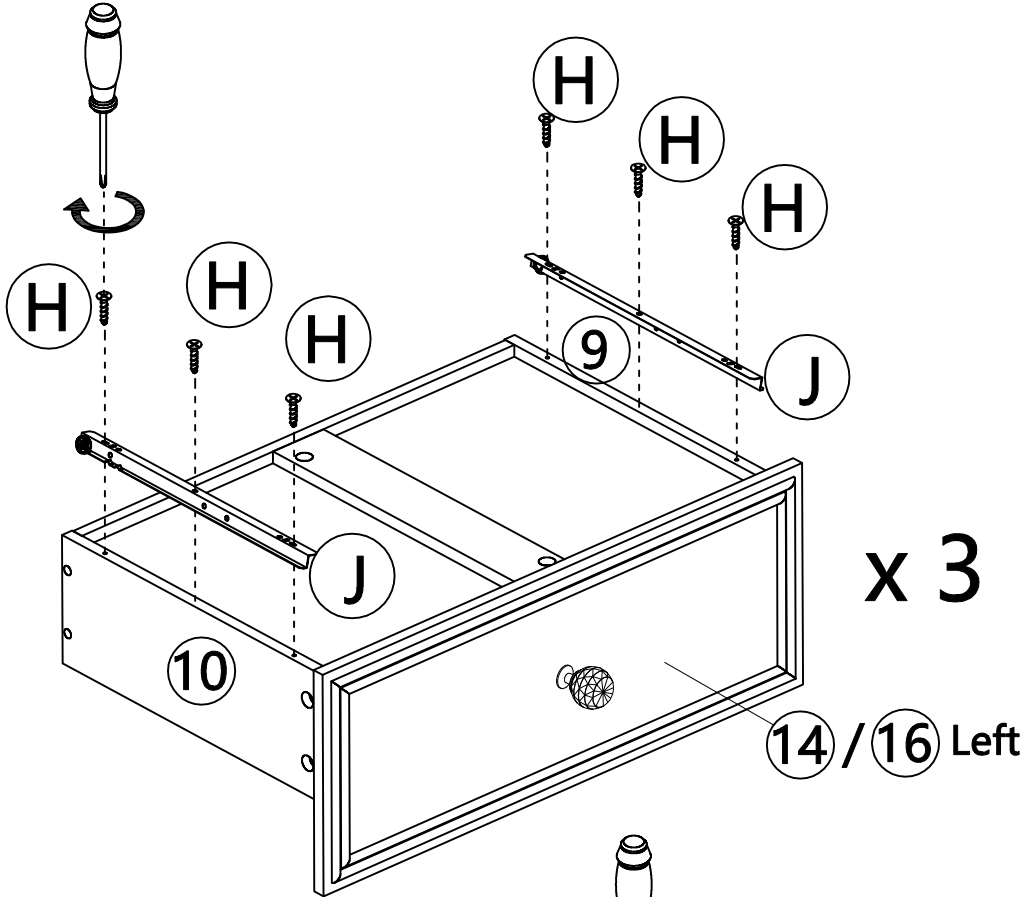
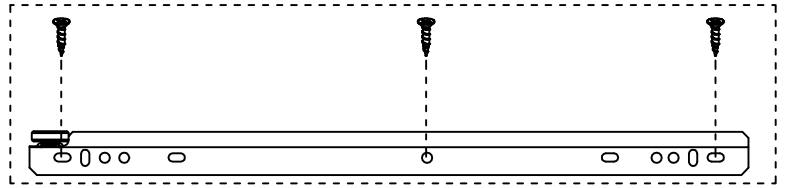

When building it make sure to take note of the drawer slides is the one similar to Z shape. And the white wheels should be installed on the back side. Repeat the previous step to install the remaining drawers.

Step 16

Note that the drawer 14/16 and drawer 15/17 is different, #14/16 board is put on the LEFT, #15/17 board is put on the RIGHT. If you put the wrong location, the drawer can not be well put in.

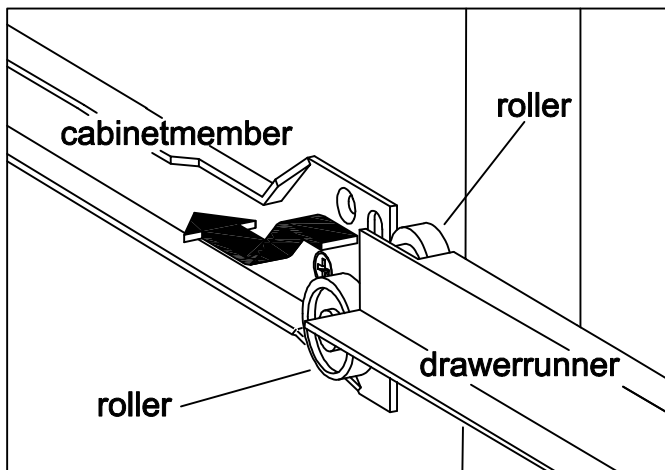
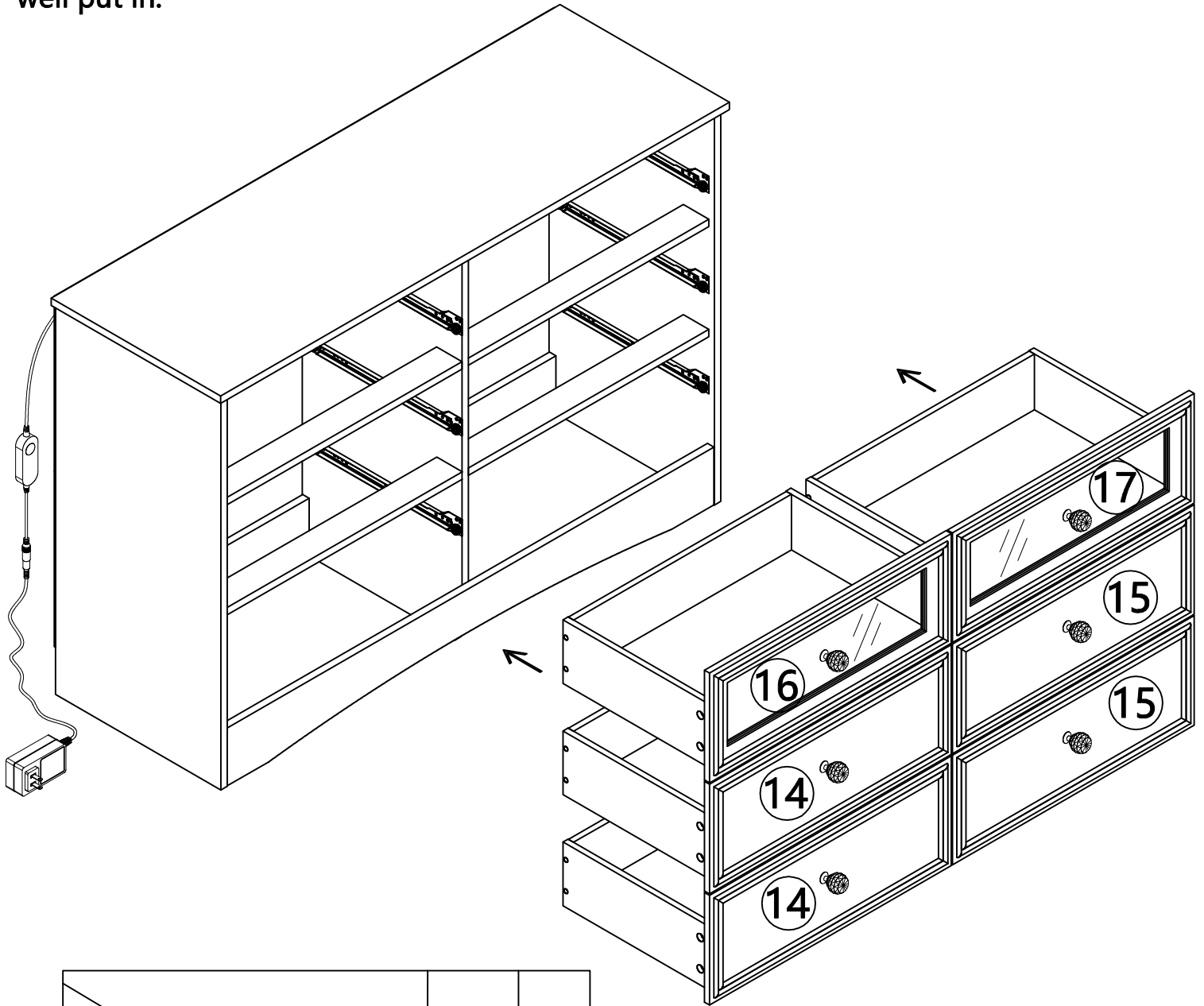

When you put the drawer, please note that the drawer wheels on top of the wheels of the slide, then check whether the drawer is smooth when pulled out. Otherwise, the drawer will not be aligned with other drawers.

Step 17

(L)

2 pcs

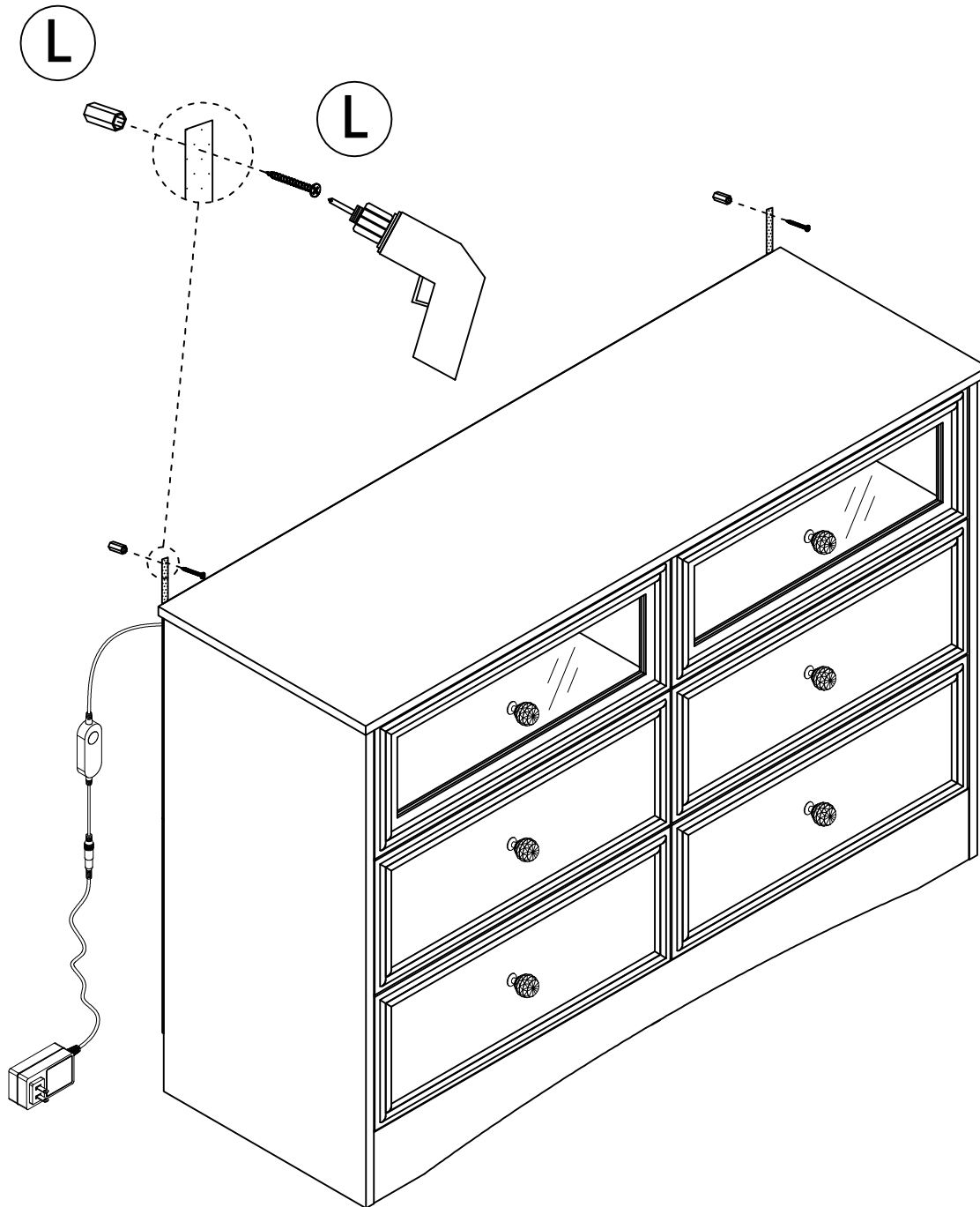

Tools required (not included): phillips screwdriver, stud finder, tape measure, pencil, power drill and 3/16" drill bit.

Now, follow the instructions printed on the plastic bag containing the tipping restraint hardware to attach the tip-over restraints to the unit and the wall.

NOTE: The tipping restraint hardware included is for wooden stud wall construction. It must be attached to a wall stud. depending upon your wall construction, different anchor hardware maybe required. please contact your local hardware store for assistance. young children can be seriously injured by tipping furniture. you must install the tipping restraint hardware with the unit to prevent the unit from tipping, causing any accidents or damage.

The tipping restraints are intended only as a deterrent, they are not a substitute for proper adult supervision. the tipping restraints are not earthquake restraints. if you wish to add the extra security of earthquake restraints, they must be purchased and installed separately.

FINAL

Great, you got a 6 drawer dresser !

