

Installation & Assembly

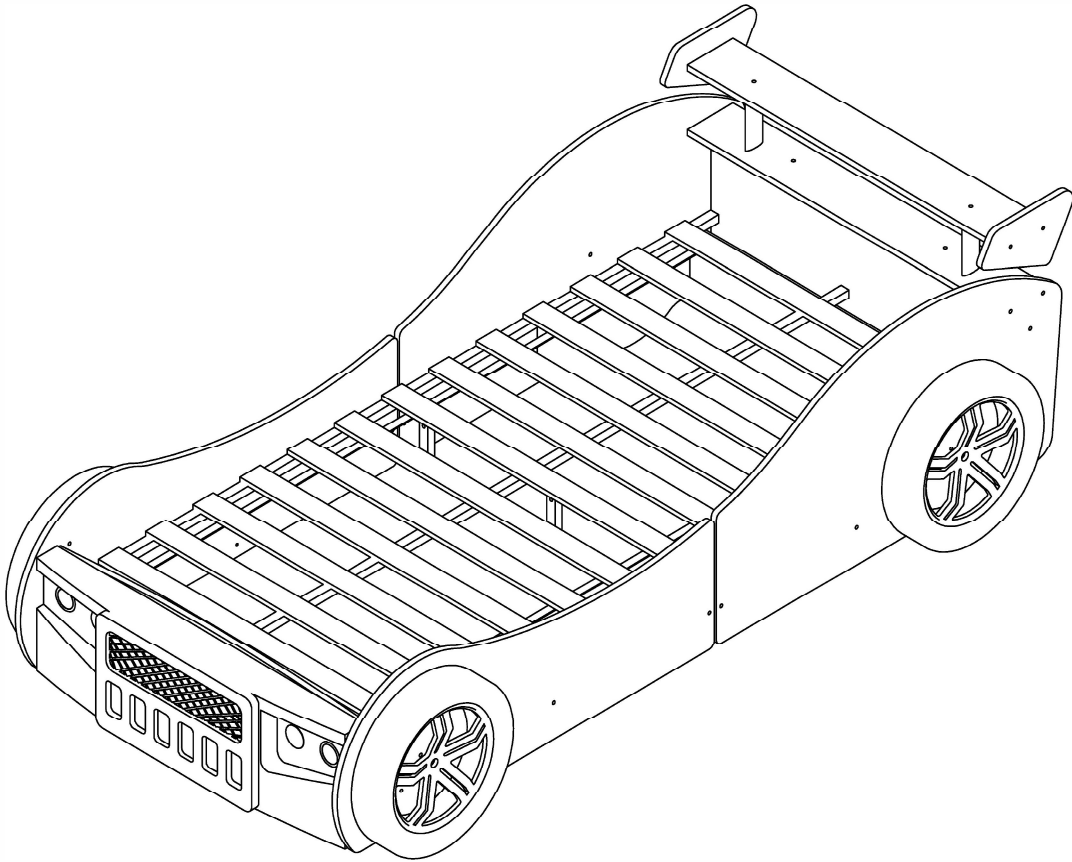

ASSEMBLE DIFFICULTY

1 2 ③ 4 5

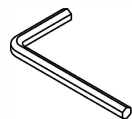
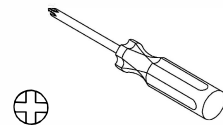
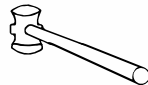
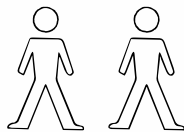



















- User Age: 72 Months Or Above.
- Standard Of Paint: EN1725:1998
EN1022:2005
EN71-1:2014
EN71-3:2013+A1:2014

IMPORTANT, RETAIN FOR FUTURE REFERENCE: READ CAREFULLY

- Information regarding maintenance
Use dry, clean & soft cloth rub on the surface regularly; must not use any wet cloth, hardware or any hard material (such as keys, knife, sand-paper) rub on the surface. Keep away from water and any chemical substances.
- Conditions for use of the product domestic
- Installation only to be carried out by a competent person
- Article consists swallowable small parts, children ≤ 3 years should not be without parental guidance (surveillance or monitoring)
- Screw lock must be inserted before joining
- For the safety reason all of the hardware must be screwed tidely.
- This Product must be assembled by adult
- To avoid surface damage, tight all serew must not use over 5Nm power.

DESCRIPTION OF COMPONENT

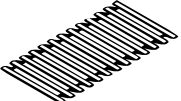
ITEM NO	WORK PIECE DESCRIPTION	MEASUREMENT	QTY	COLOUR	SHAPE	PACK IN BOX
(1)	FRONT SIDE BOARD (L)	1066*439*15	1	RED		1/2
(2)	FRONT SIDE BOARD (R)	1066*439*15	1	RED		1/2
(3)	FRONT SIDE BOARD (L)	1066*593*15	1	RED		1/2
(4)	REAR SIDE BOARD (R)	1066*593*15	1	RED		1/2
(5)	BATTEN-1	953*25*22	4	WHITE		2/2
(6)	BATTEN-2	953*25*22	2	WHITE		2/2
(7)	BACK PANEL	1000*354*15	1	RED		1/2
(8)	REAR UPPER MIDDLE FILTER	1000*135*15	1	RED		1/2
(9)	REAR LOWER MIDDLE FILTER	1000*135*15	1	RED		1/2
(10)	BEAM	1000*100*15	4	WHITE		1/2
(11)	MIDDLE HORIZONTAL PLATE	1000*100*15	2	WHITE		1/2
(12)	ARTICLE RIBS	216*25*20	2	WHITE		2/2
(13)	REAR UPPER SIDE BOARD (L)	272*162*15	1	RED		2/2
(14)	REAR UPPER SIDE BOARD (R)	272*162*15	1	RED		2/2
(15)	CONNECTED IRON	150*50*20	2	BLACK		2/2
(16)	FRONT PANEL (ITEM 12-14 INCLUDED IN THIS PART)	1000*300*15	1	RED		2/2
(17)	TYRE (ITEM 16-17 INCLUDED IN THIS PART)	380*380*62	4	BLACK		2/2
(18)	HARDWARE	216*114*57	1	BROWN		2/2
(19)	PLYWOOD SLAT	1900*995*12	1	WHITE		1/2

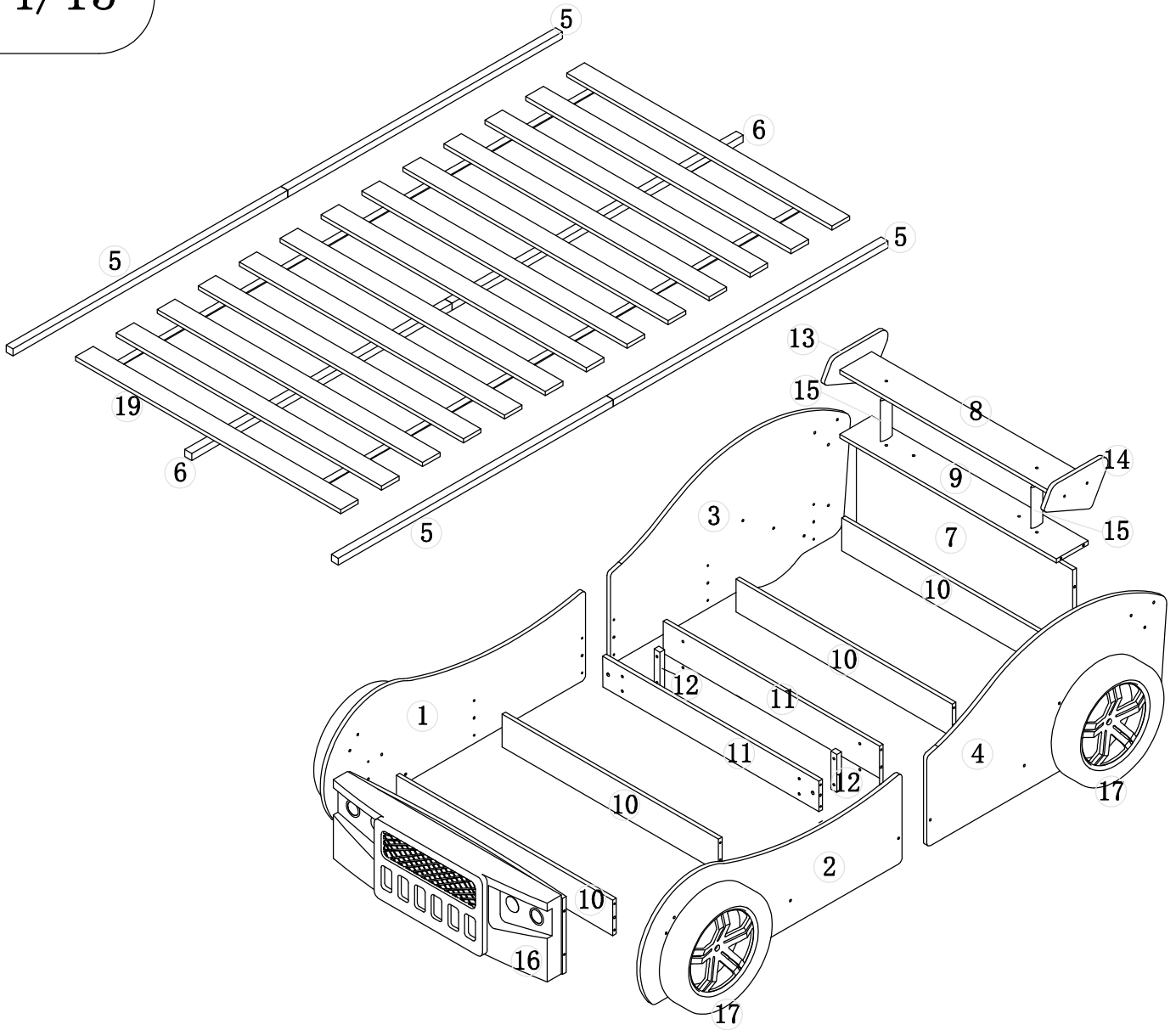

A	B	C	D	E	F
M6*55 QTY:4	QTY:4	M6*50 QTY:30	d6*30 QTY:24	QTY:4	4#*30 QTY:12

G	H	I	J	K	L	M
QTY:30	M6*40 QTY:4	M6*70 QTY:4	4#*20 QTY:12	QTY:8	QTY:1	QTY:4

SCALE 1:1

A

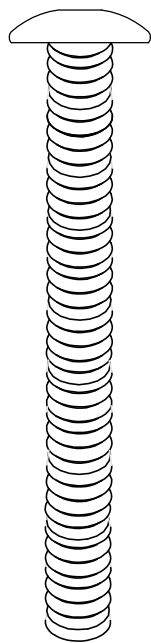

M6*55

C

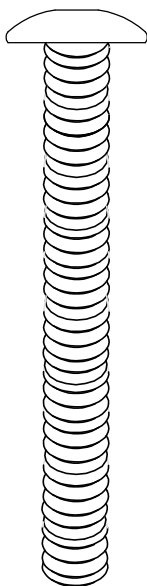

M6*50

H

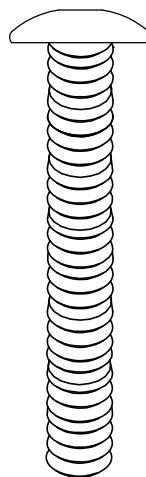

M6*40

I

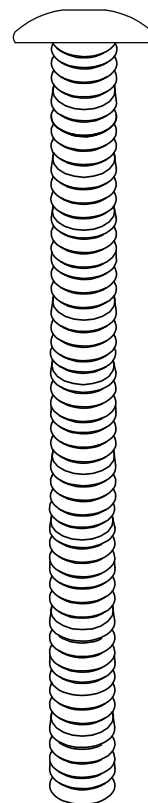

M6*70

1

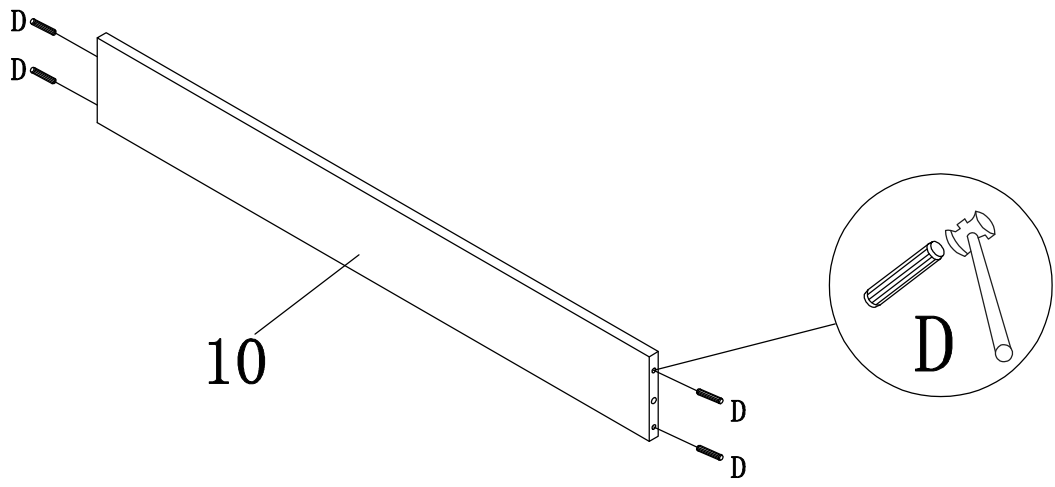

4X

D



d6*30
QTY: 16

2

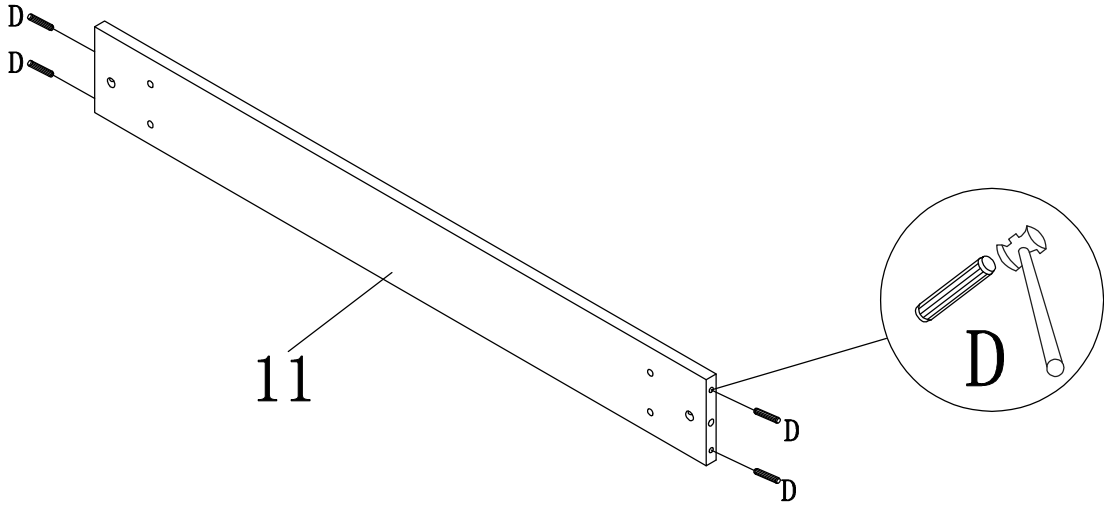

2X



D



d6*30
QTY: 8

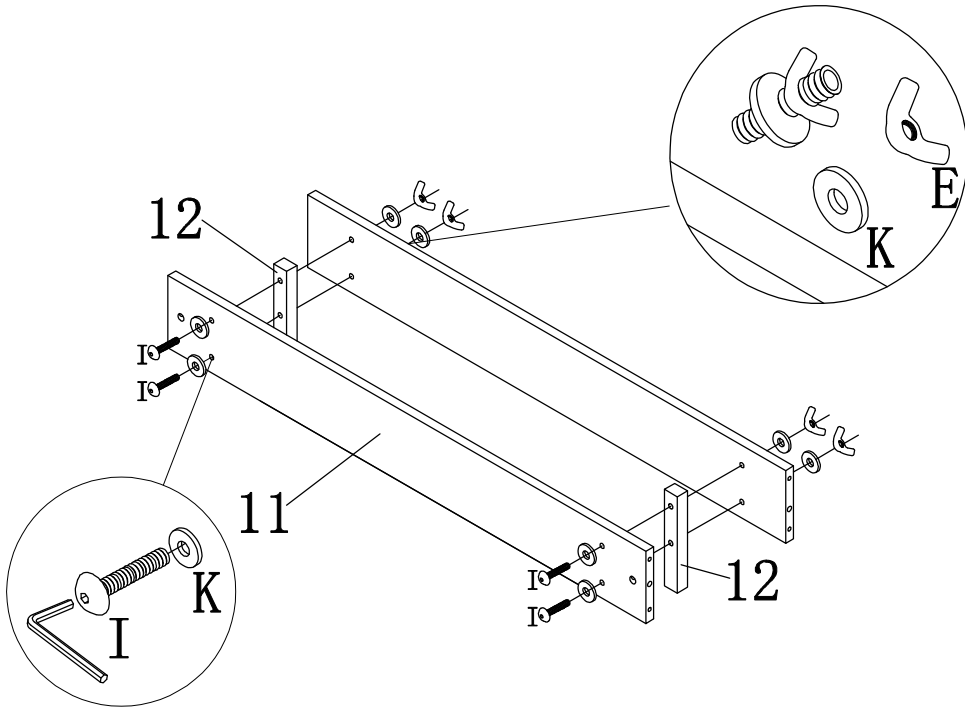

3

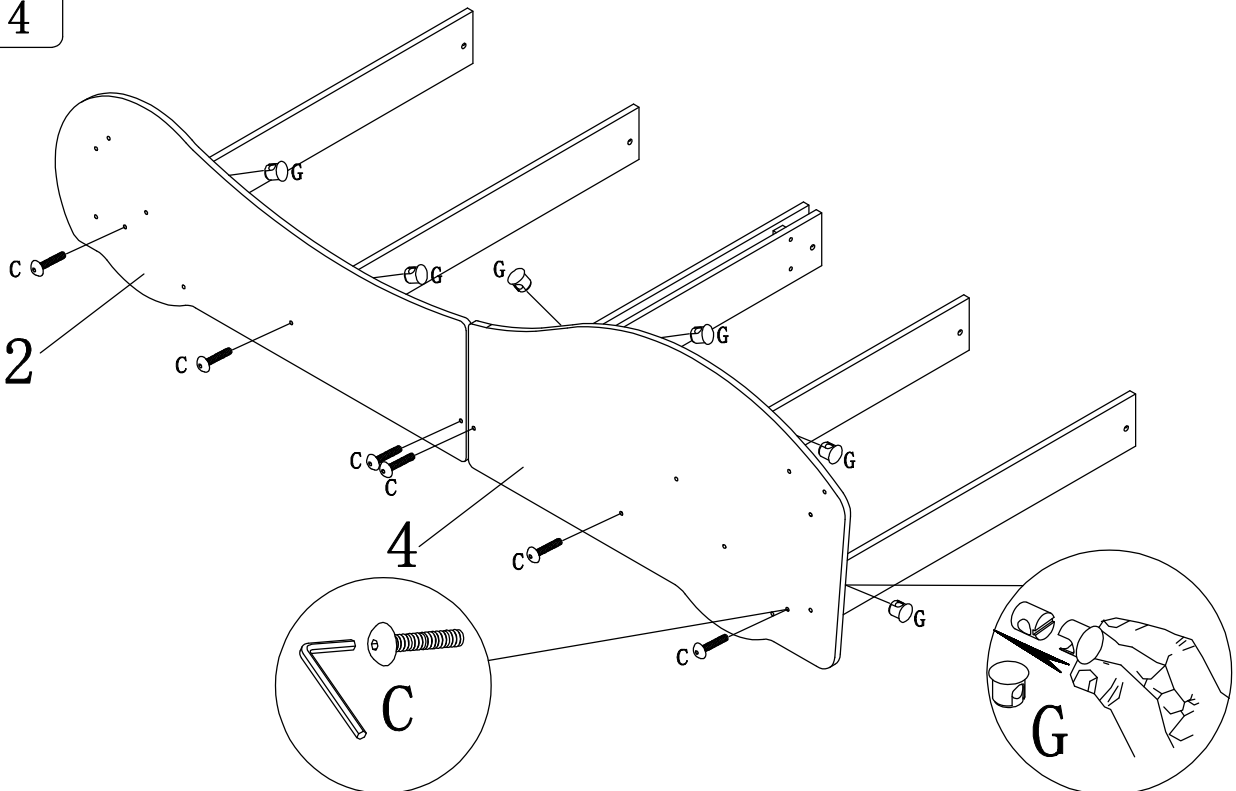

I		M6*70 QTY:4	E		QTY:4	K		QTY:8
---	--	----------------	---	--	-------	---	--	-------

4



C		M6*50 QTY:6	G		QTY:6
---	---	----------------	---	---	-------

5

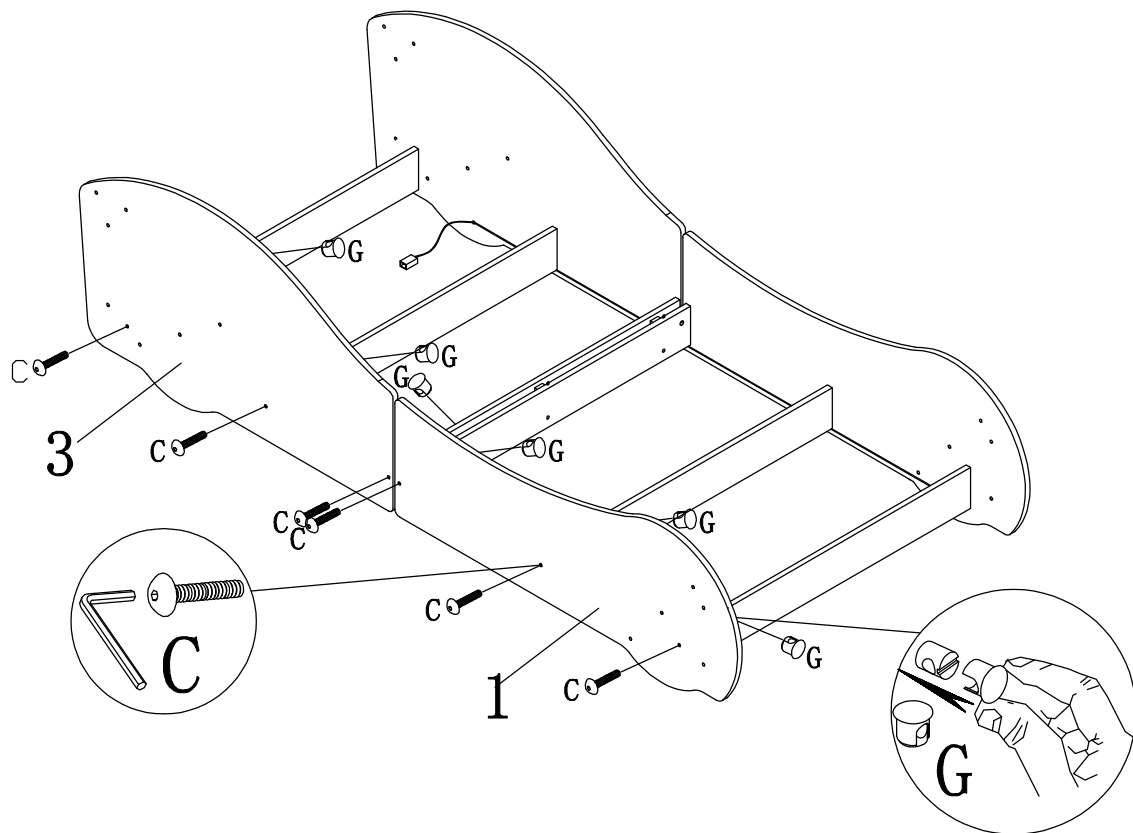

C



M6*50
QTY:6

G



QTY:6

6

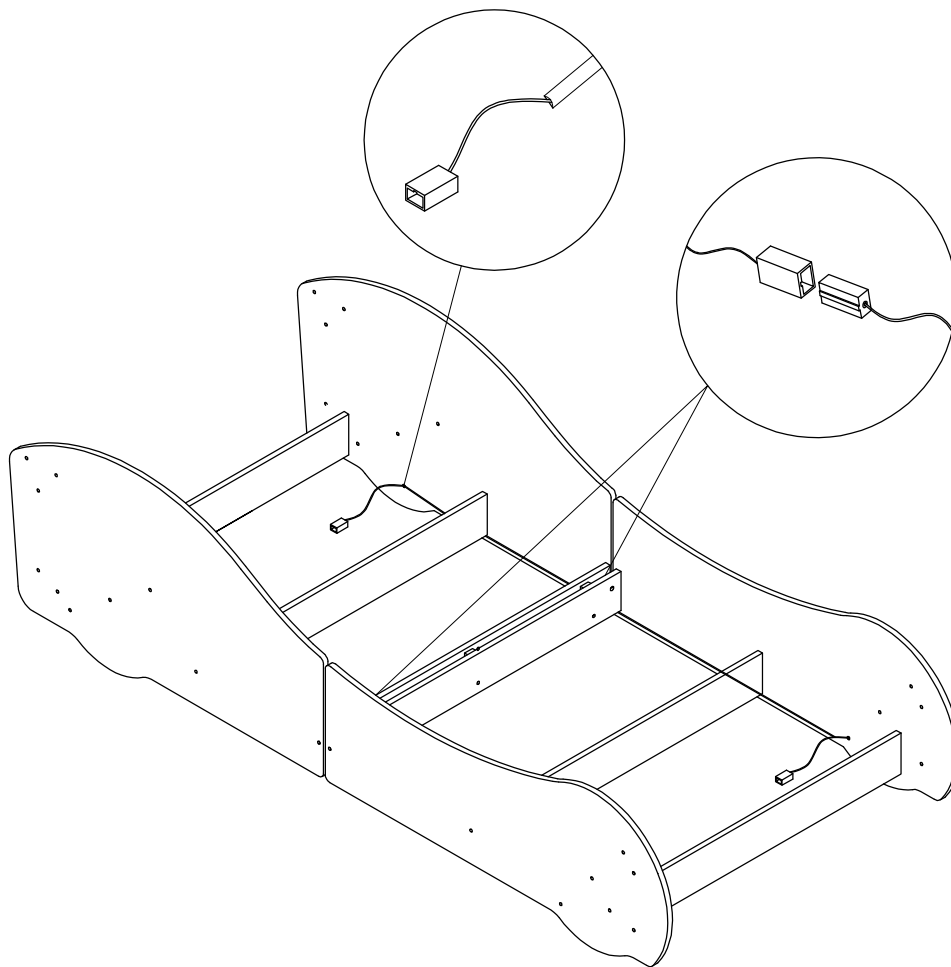

7

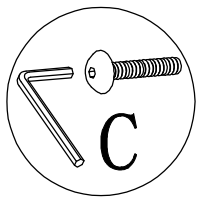
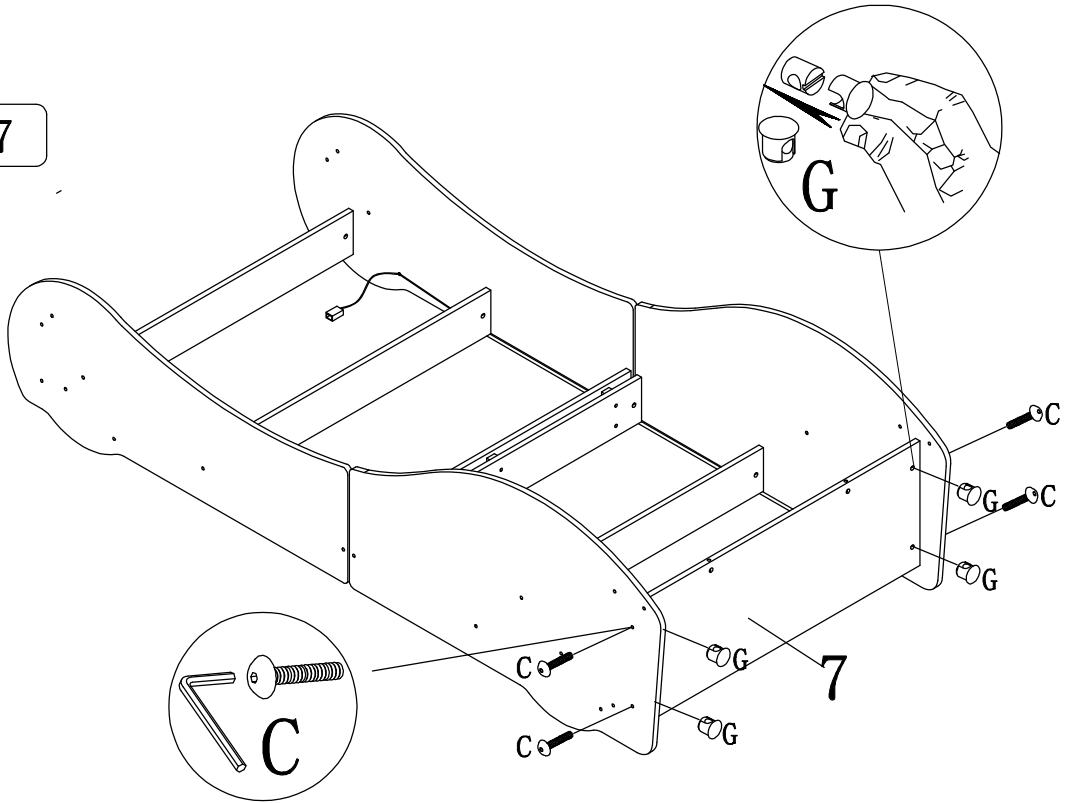

C  **M6*50**
QTY:4

G  **QTY:4**

8

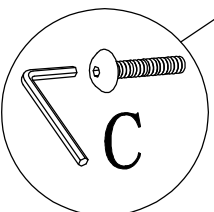
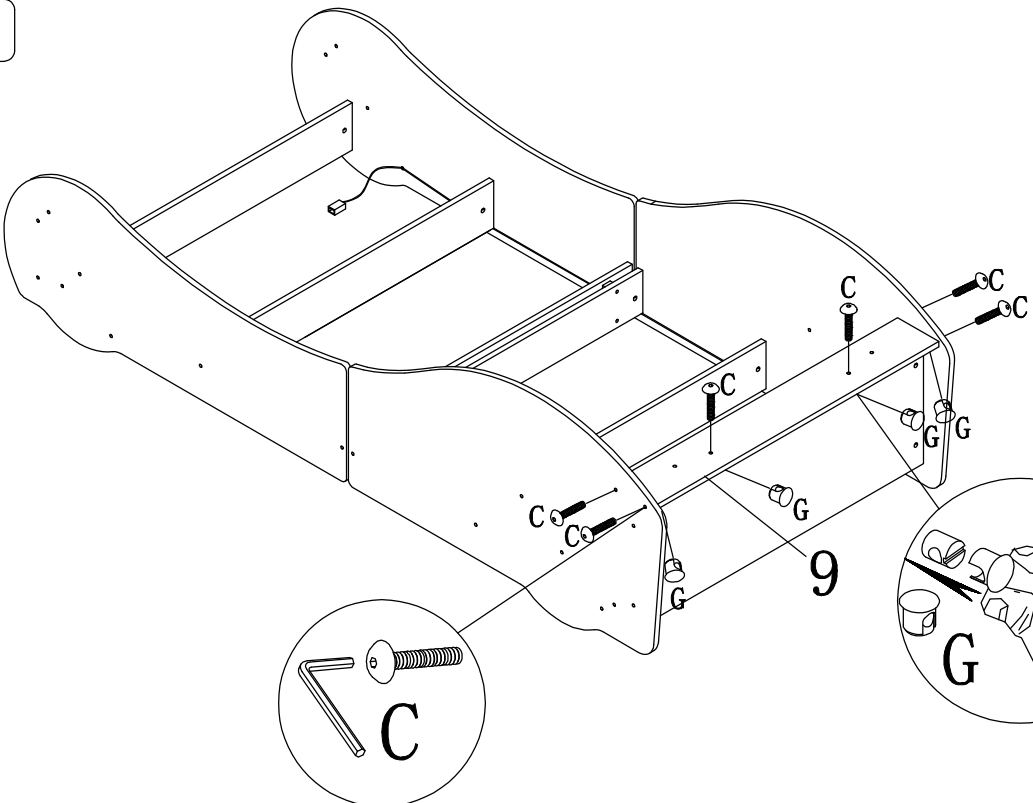

C  **M6*50**
QTY:6

G  **QTY:6**

9

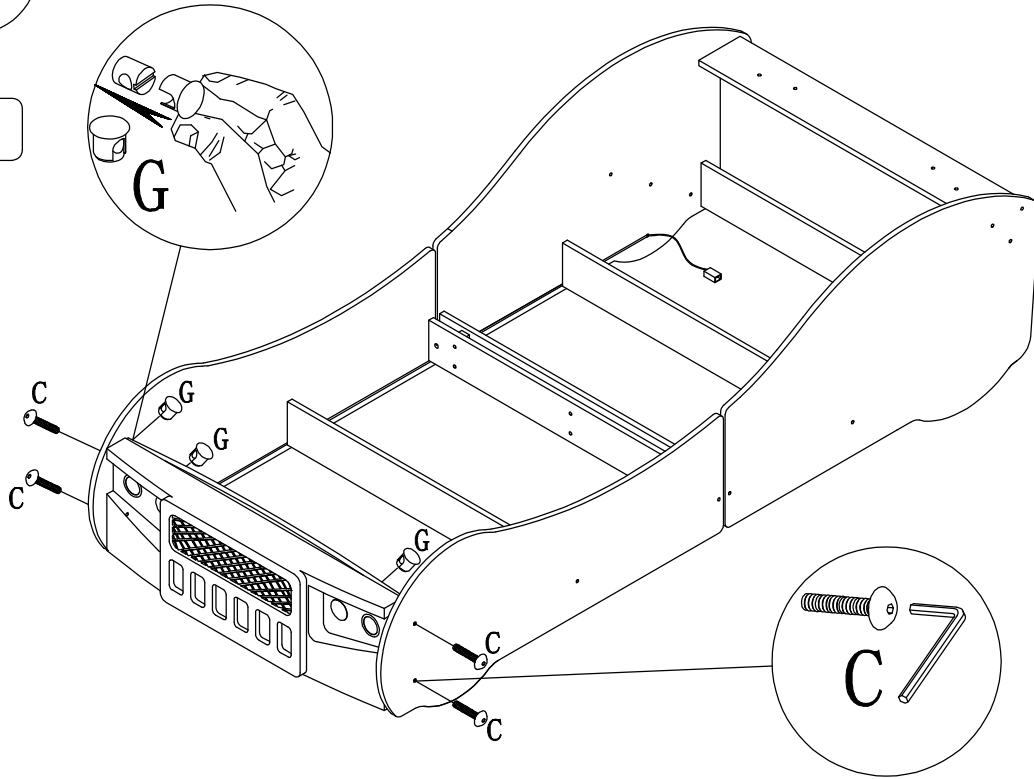

C

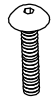

M6*50
QTY:4

G



QTY:4

10

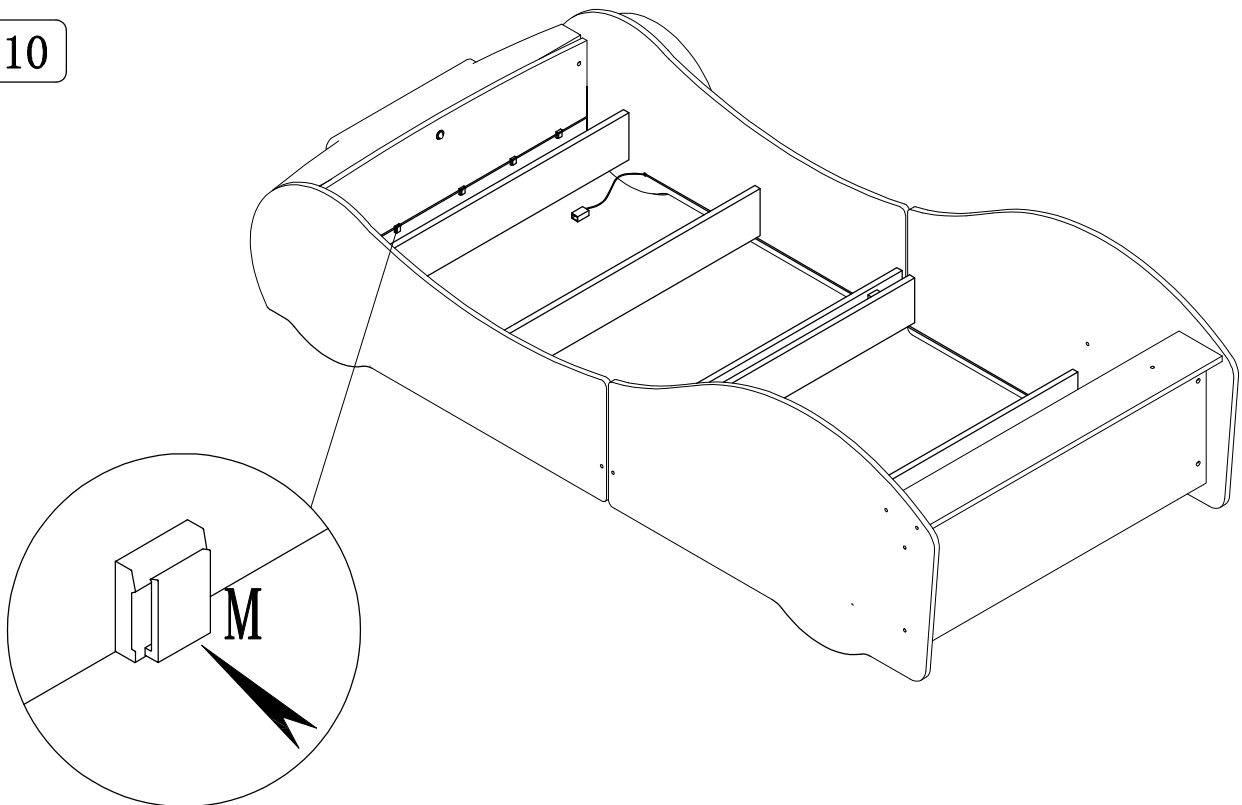

M



QTY:4

11

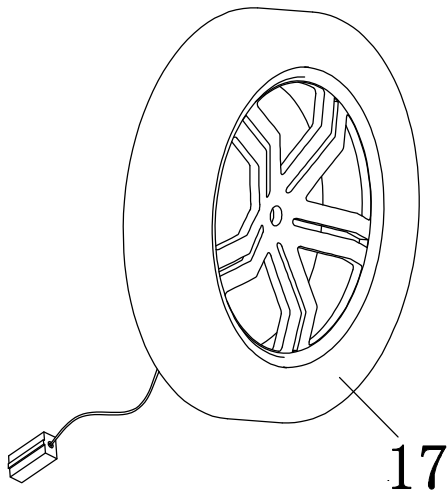

12

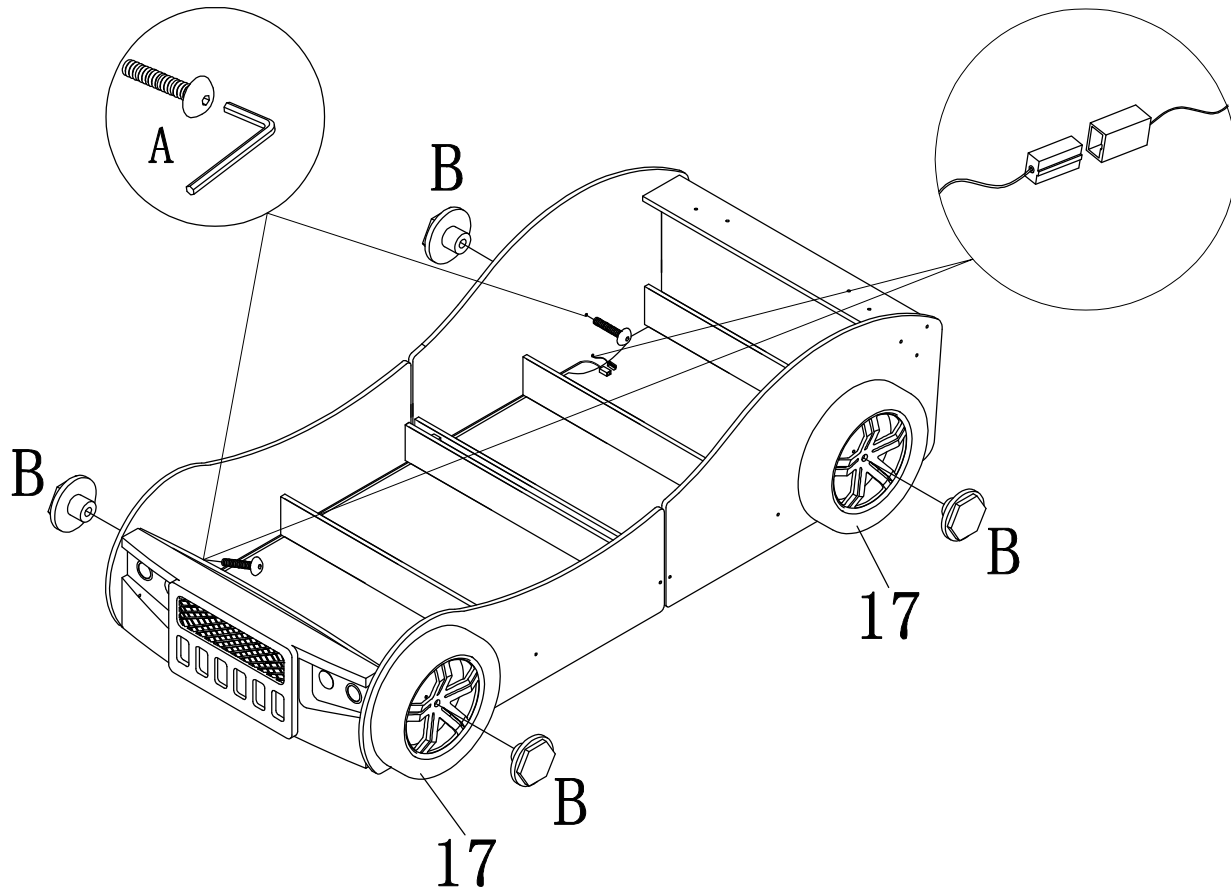

A



M6*55
QTY: 4

G



QTY: 4

13

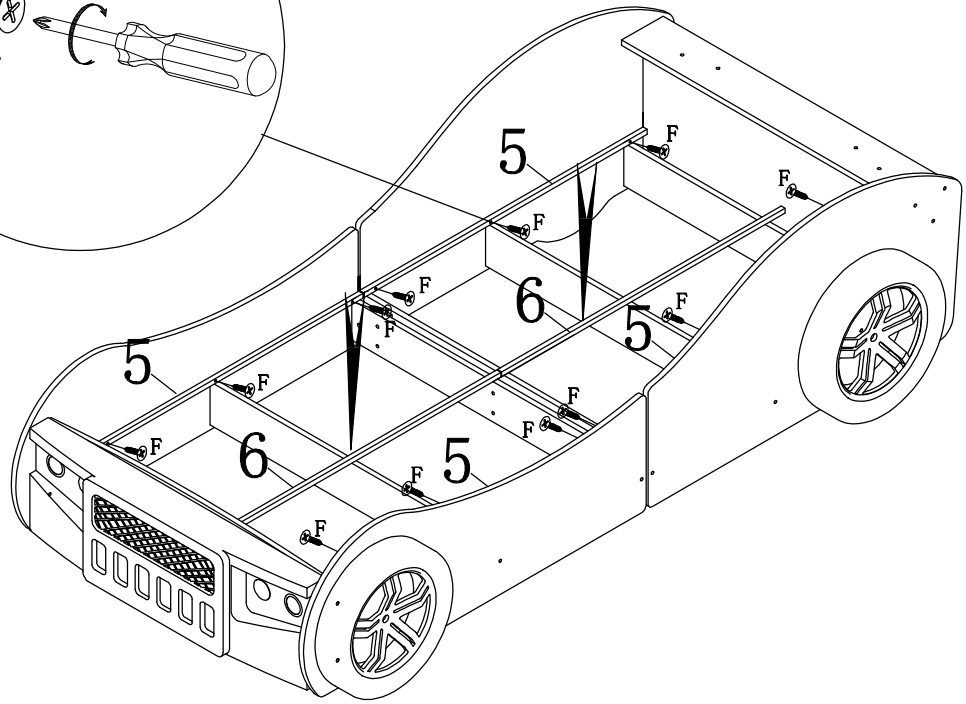
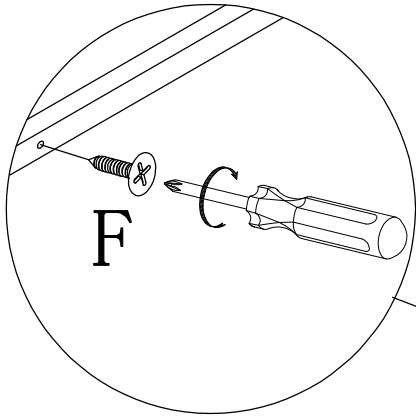

F



4#*30
QTY:12

14

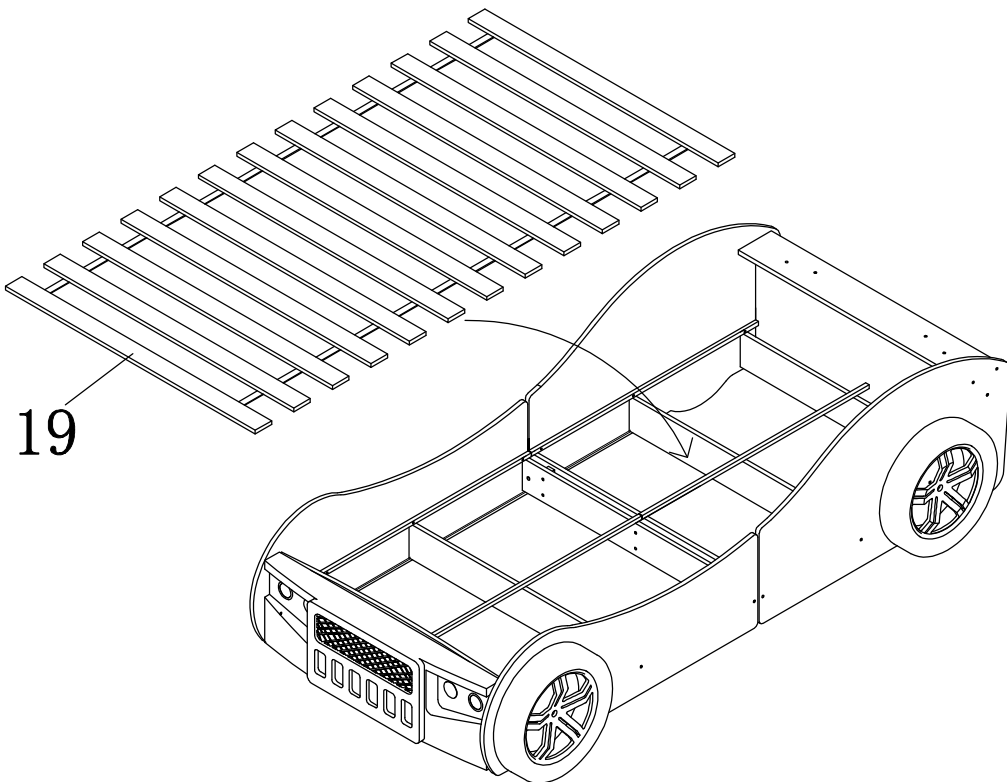

15

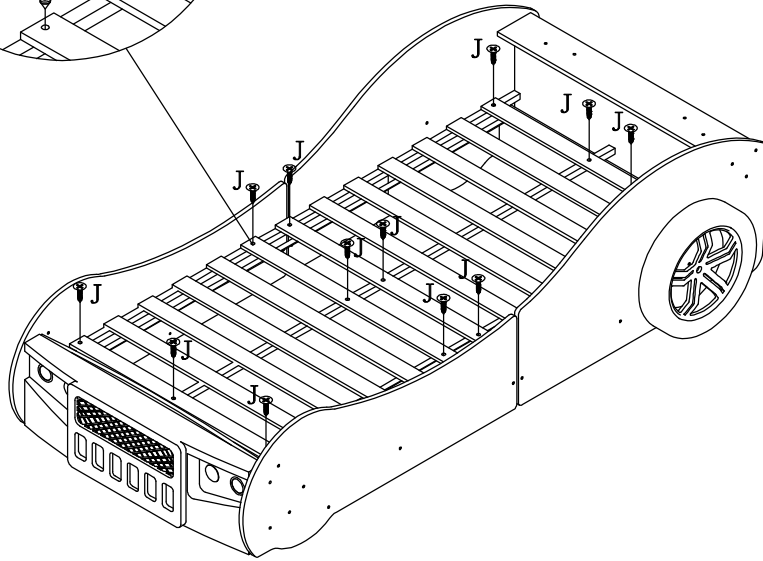
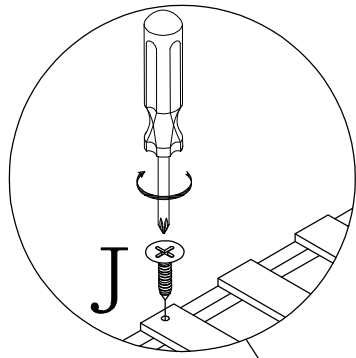

J



4#*20
QTY:12

16

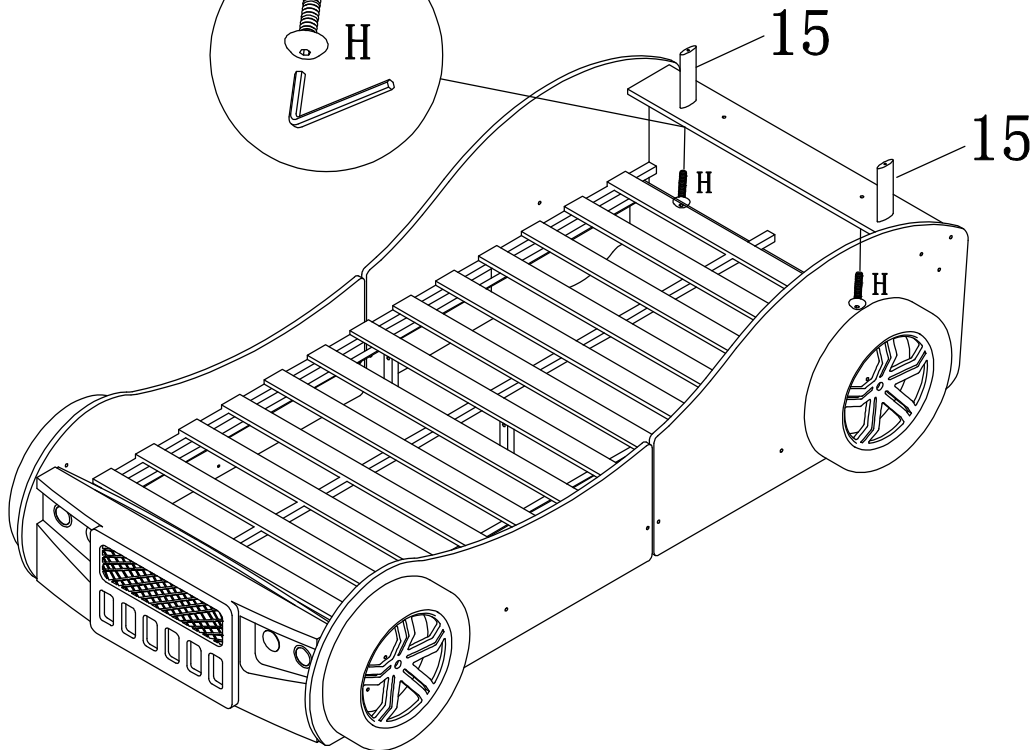
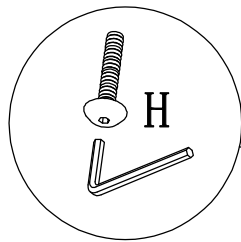

H



M6*40
QTY:2

17

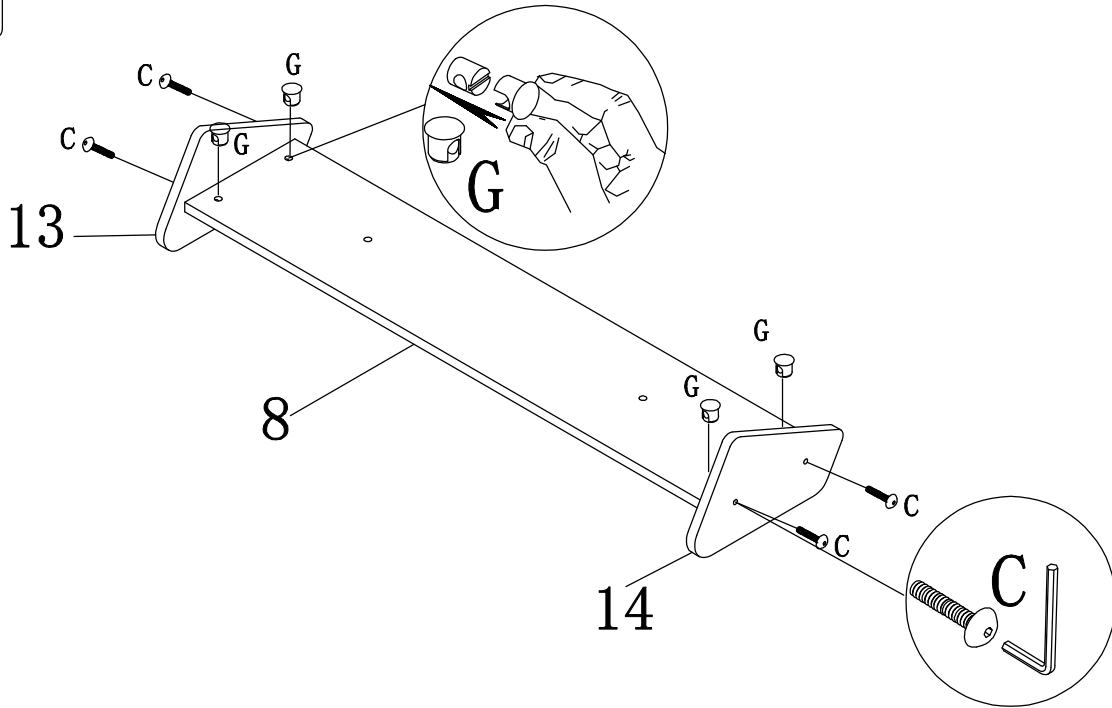

C

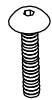

M6*50
QTY:4

G



QTY:4

18

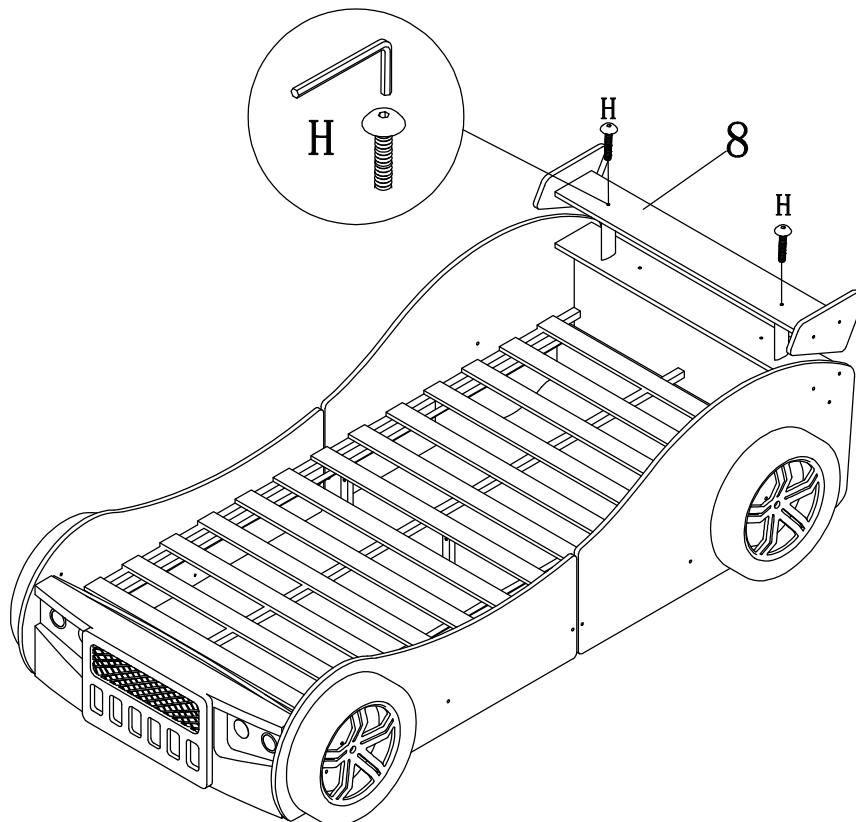

H



M6*40
QTY:2

19

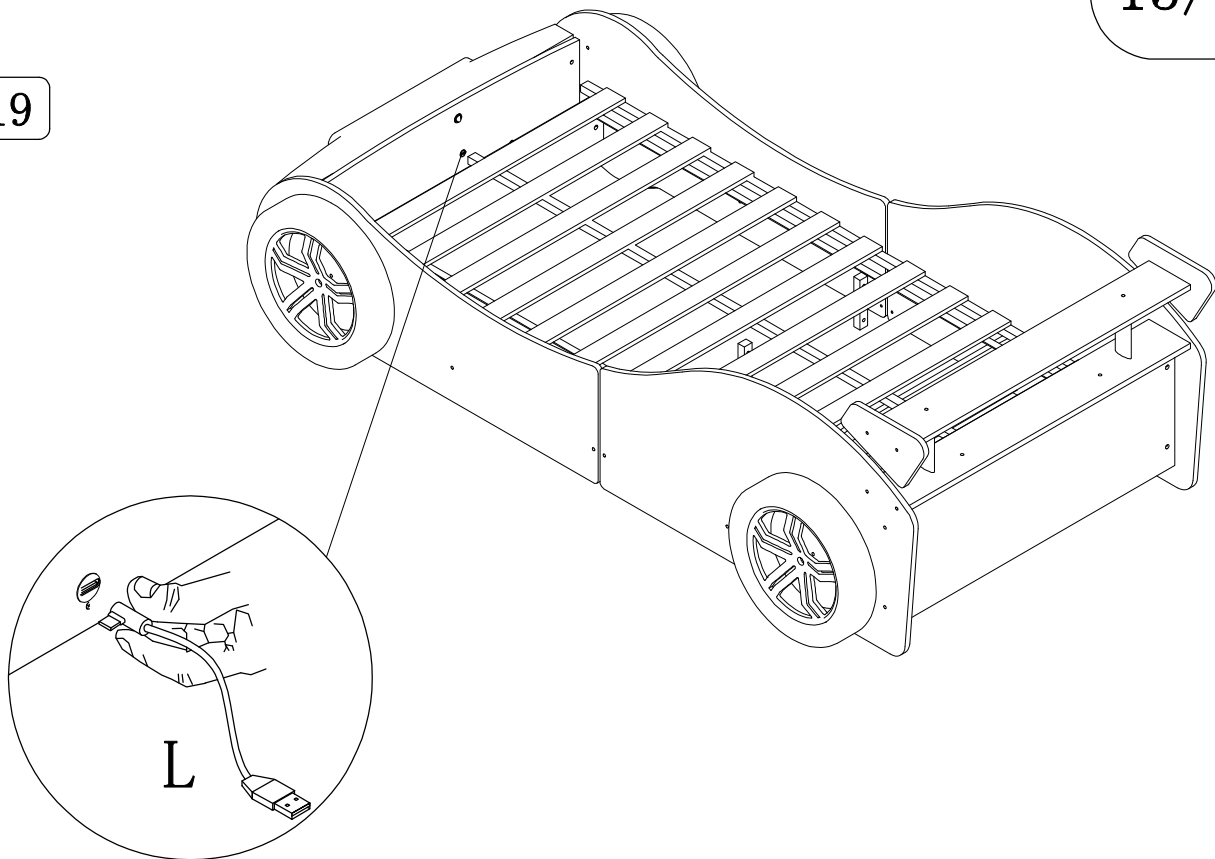

L



QTY:1

20

