

## Magnesium Mineraliser In-Line Drinking Water Filter Kit

### Installation and Operating Instructions

#### Model: MMDWK



#### Specifications:

**Pressure Range:** 30 – 72 psi (2.1 – 5.0 bar)

**Temperature Range:** 40 – 77°F (5 – 25°C)

**Rated Service Flow:** 2.0 Lpm

**Filter Capacity:** 3 to 6 months (depending on hardness)

#### Parts Included:

- Part No. MMDWFCART filter cartridge  
C/W integral push-fits connections
- Mounting bracket C/W Screws
- Self piercing valve with tube attached
- Drinking water tap

#### Tools required:

- Phillips Screwdriver
- Towel
- Drill
- Tape Measure
- File or Sandpaper
- Pencil
- 6 mm (1/4") Drill Bit
- 12 mm ( 1/2") Drill Bit

#### Precautions:

**WARNING:** Do not use with water that is microbiologically unsafe or of unknown quality without adequate disinfection before or after the system. Systems certified for cyst reduction may be used on disinfected waters that may contain filterable cysts.

**CAUTION:** This filter must be protected from freezing, which can cause cracking of the filter and water leakage.

**CAUTION:** Because of the product's limited service life and to prevent costly repairs or possible water damage, we strongly recommend that the head of the filter be replaced every ten years. If the head of your filter has been in use for longer than this period, it should be replaced immediately. Date the top of any new head to indicate the next recommended replacement date.

**CAUTION:** Turn off water supply to head without cartridge if it must be left unattended for an extended period of time.

- For cold water use only.
- Make certain that installation complies with all local bylaws and regulations.
- The contaminants or other substances removed or reduced by the selected cartridge are not necessarily in your water. Ask your local water supplier for a copy of their water analysis.
- After prolonged periods of non-use (such as during a holiday) it is recommended that the system be flushed thoroughly. Let water run for 2-3 minutes before using.
- The filter cartridge used with this system has a limited service life. Changes in taste, odour, colour; and/or flow of the water being filtered indicate that the cartridge should be replaced.

#### Installations:

- For standard installations on 15 mm copper, cold water pipe.
- Please read all instructions and precautions before installing and using your under-sink drinking water system.
- Numbered diagrams correspond with numbered steps.

## 1. Selecting the Tap Location

**NOTE:** The drinking water tap should be positioned with function, convenience and appearance in mind. An adequate flat area is required to allow tap base to rest securely whether fitted directly to your sink or an adjacent worktop.

### 1. Preparing to Fit the Tap

**CAUTION:** Do not attempt to drill through an all porcelain sink. If your sink is porcelain, please consult a professional plumber about installation.

**WARNING:** Wear safety glasses to prevent eye injury.

#### Sink Location

The following instructions apply to stainless steel sinks only.

- (A) Line bottom of sink with newspaper to prevent metal shavings, parts, or tools from falling down the drain and damaging sink or disposal unit if fitted.
- (B) Mark hole with a centre punch. Use a 6mm drill bit for a pilot hole, then using a 12mm diameter bit, drill a hole completely through the sink. Smooth rough edges with a round or half round file.

#### Worktop Location

- (C) The tap should be positioned on a work surface adjacent to a sink where the spout can easily discharge water into the basin.
- (D) Using a pencil, mark the work surface to indicate the centre of the tap.
- (E) Drill a 12 mm hole where marked on the work surface.
- (F) Smooth any rough edges with a round or half round file.

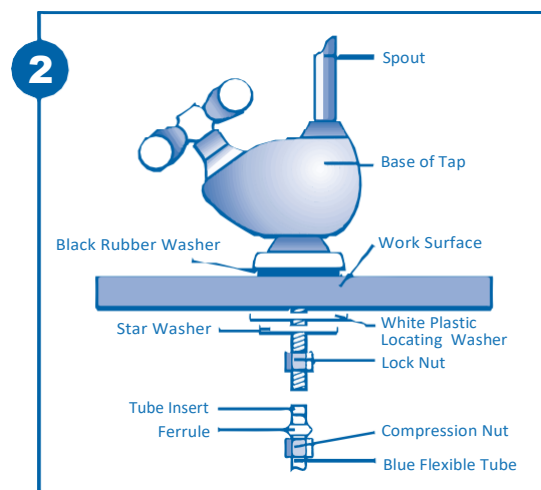
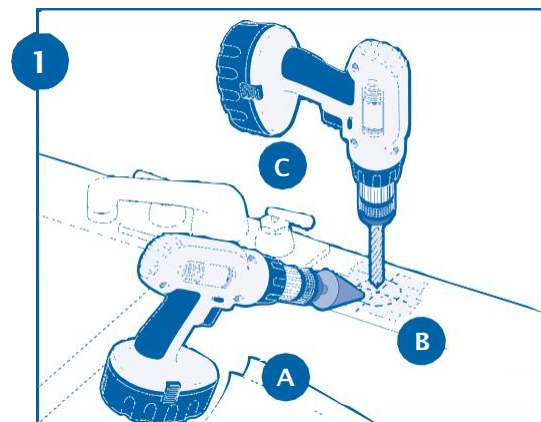

## 2. Installing the Quarter Turn Tap

- (A) Insert the black rubber washer into the base of the tap.
- (B) Insert the threaded section of the tap body into the 12 mm hole.
- (C) Assemble the washers and lock nut on the threaded section underneath the sink.
- (D) Tighten the lock nut to prevent the tap moving. Do not over tighten.
- (E) Ensure compression nut, ferrule and tube insert are positioned on the blue flexible tube shown Fig 2.
- (F) Insert the open end of the blue flexible tube assembly into the base of the threaded section of the tap.
- (G) Tighten the compression nut to ensure a watertight seal. Do not over tighten.

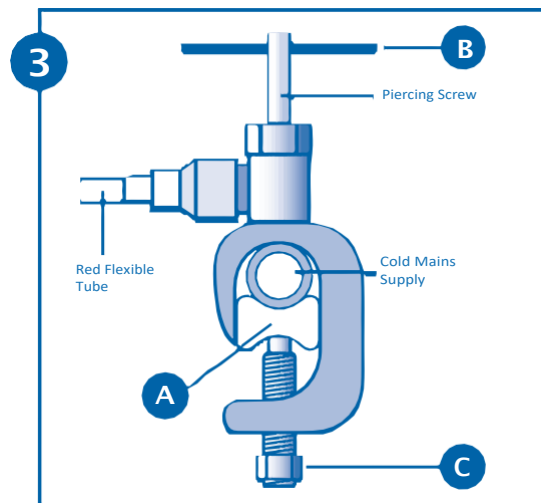

## 3. Installing the Saddle Valve

**Before carrying out any installation TURN OFF THE WATER SUPPLY AT THE MAIN STOP COCK.**

- Place the saddle clamp on to the cold mains supply pipe to the kitchen sink. Make sure that the SADDLE A is in place as shown in the diagram.
- Tighten the locking screw C to clamp the pipe securely.
- Turn the piercing screw B clockwise and fully home to puncture the pipe, leave in this position.

## 4. Mounting the Filter System

- (A) Taking note of the length of connecting tube available select a suitable position for the cartridge (normally on the side of the cupboard underneath the sink)
- (B) Using the bracket as a guide mark the position of the fixing holes with a pencil.
- (C) Drill a small pilot hole for the screw.
- (D) Fix the bracket supplied to the side of the cupboard using suitable screw (wood screw supplied an alternative fixing may be required)
- (F) The cartridge can be clipped into the bracket or removed at anytime to help with remaining installation.

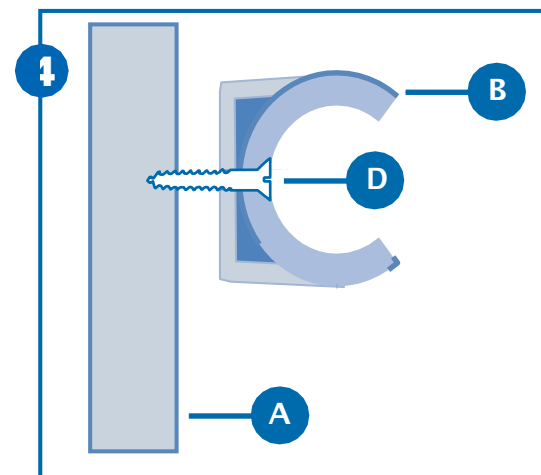

## 5. Final assembly

- A) Using a sharp hobby knife or similar to cut the flexible red tube from the self piercing valve to a length suitable for it to reach the inlet side of the filter cartridge. Remember to allow a sufficient length, so that it can be routed without kinks and be kept clear of any sharp edges or obstacles.
- B) With the tube cut 'squarely' and to the right length, ensure the end is clean before firmly pushing it into the push fit connector on the inlet side of the filter cartridge, pull back slightly to affect a water tight seal.
- C) Repeat process for the touch flow tap, attaching tube to the outlet side of the cartridge.
- D) Turn on water supply and check all connection for leaks.
- E) Turn on the quarter turn tap to remove any airlocks. Run water for several minutes until water runs clear to flush and prime cartridge.

**NOTE:** for optimum performance, flow rate should not exceed 2 Lpm.

## 6. Filter Cartridge Replacement

**NOTE:** It is recommended that the cartridge be replaced every six months, or when you notice a change in taste, odour or flow of the water being filtered.

- A) Turn off the water supply to the filter and dispense water from drinking water tap until water flow stops to relieve pressure.
- B) Place a small bowl and towel under the filter to catch any water drips.
- C) If necessary remove filter cartridge from the bracket to improve your access.
- D) Now disconnect the red and blue tube from the filter cartridge one at a time by placing your finger and thumb either side of the tube where it enters the filter cartridge and pushing the small white collar toward the filter body this will release the tube. Hold the collar in this position and gently pull the tube out of the cartridge.
- E) Remove and dispose of the cartridge, recycling where facilities exist.
- F) Fit the new cartridge by simply pushing the end of the red tube into the push fit connector on the inlet side of the filter cartridge, pull back slightly to affect a water tight seal.
- G) Repeat process for the blue tube, attaching it to the outlet side of the cartridge.
- H) Turn on water and check for leaks.
- I) Flush water through drinking water tap for up to 5 minutes to remove air, and any excess filter media.

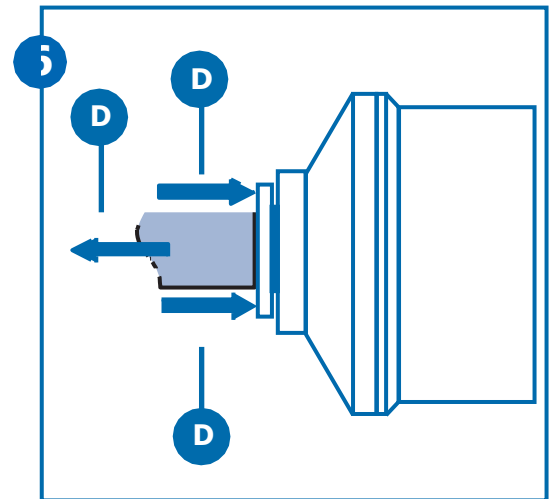
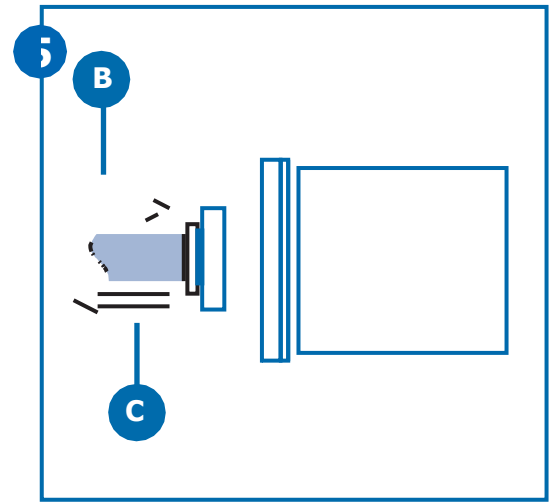

# BWT In-line Water Filter Kits

## Trouble Shooting Guide

Fault	Cause	Action
No filtered water	Water intake or isolating valve closed Filter reversed Filter not fitted correctly Mains water turned off Pipes are kinked	Check isolating valves and open if necessary. Check flow direction a reverse filter if necessary. Check fittings are correctly attached. Turn on mains water. Reroute pipe with smooth and sweeping bends.
Leaking around the filter	Poor joint integrity Cracked filter body	Check pipes are cut squarely and fully inserted into the push-fit connectors, remembering to pull back on the pipe to complete the joint. Isolate system and replace filter.
Low flow rate	System pressure is too low	Check system pressure is greater than 2 bar.
Air bubbles in water	Not completely bled	Repeat the bleeding procedure.
Water is milky/white in colour	Process-related formation of carbonic acid that escapes as small white bubbles	Cloudiness should disappear after approx. 5 min. If symptoms persist, please contact us on the number below.
Saddle valve leaking		Turn off self piercing valve and turn on drinking water tap to release any pressure. Placing a small bowl under the tap to catch any water, carefully loosen and remake the joint, ensuring the tap is properly aligned to the main pipework. Open the water supply valve, then close tap and check for leaks. If the leaks persist, or if there are other leaks on the unit, turn off the water supply then call Technical Support on the number below.
<b>If your problem persists, please call our Customer Service Team during office hours on 01494 838 100.</b>		

## Europes No. 1 in Water Technology

### CONTACT

BWT UK Limited,  
BWT House,  
Coronation Road,  
High Wycombe,  
Buckinghamshire,  
HP12 3SU

**Tel:** 01494 838 100

**Fax:** 01494 838 101

**Email:** [enquiries@bwt-uk.co.uk](mailto:enquiries@bwt-uk.co.uk)

[www.bwtuk.co.uk](http://www.bwtuk.co.uk)

BWT 2016. In the interests of product development, we reserve the right to alter specifications without prior notice. All photographs and dimensions are given for guidance only. Terms and conditions apply. E&OE.



For You and Planet Blue.