

NOTE:DO NOT TIGHTEN ANY OF THE BOLTS UNTIL FULLY ASSEMBLED  
**ASSEMBLY INSTRUCTION**

**2 PIECES STOOL SET**

- #1 SEAT BOARD (2)
- #2 SEAT FRAME (2)
- #3 U SHAPE LEG ATTACHED LONG NUT (2)
- #4 L SHAPE LEG (4)
- #5 FOOT REST (2)
- G SUPPORT LONG BOLT (2)
- H TIGHTENING HANDLE (2)

NOTE:DO NOT TIGHTEN ANY OF THE BOLTS UNTIL FULLY ASSEMBLED

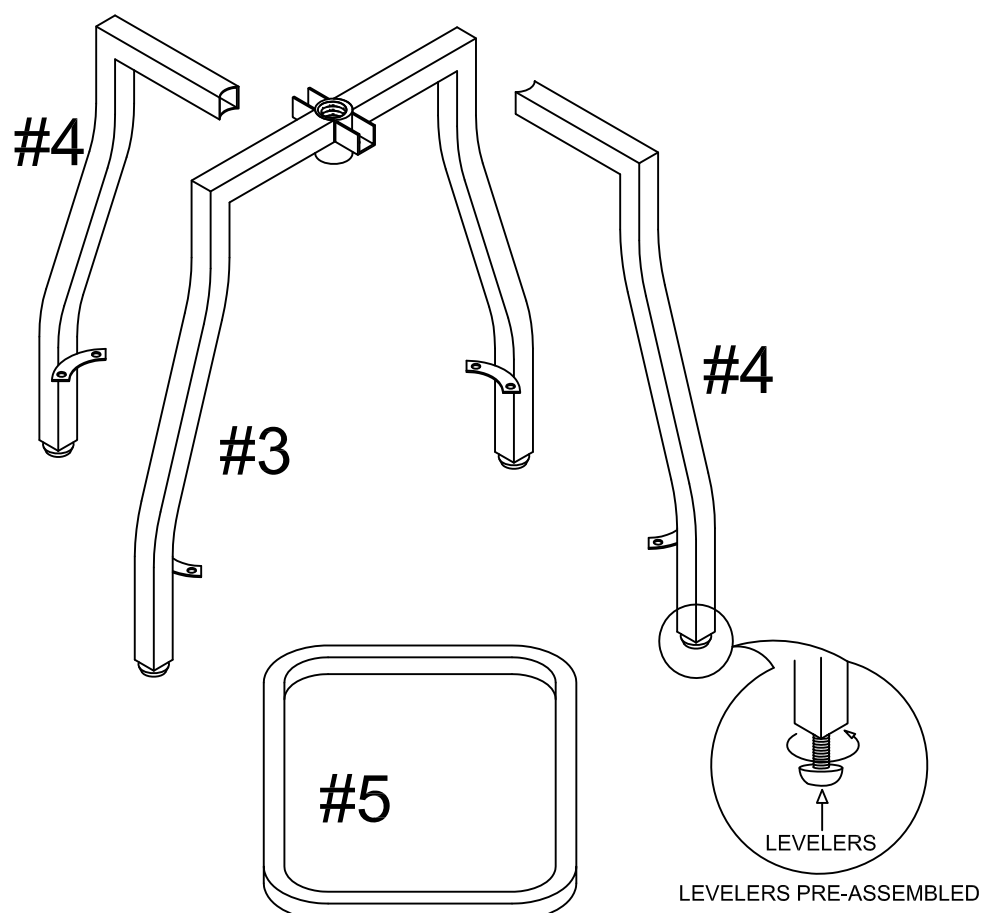
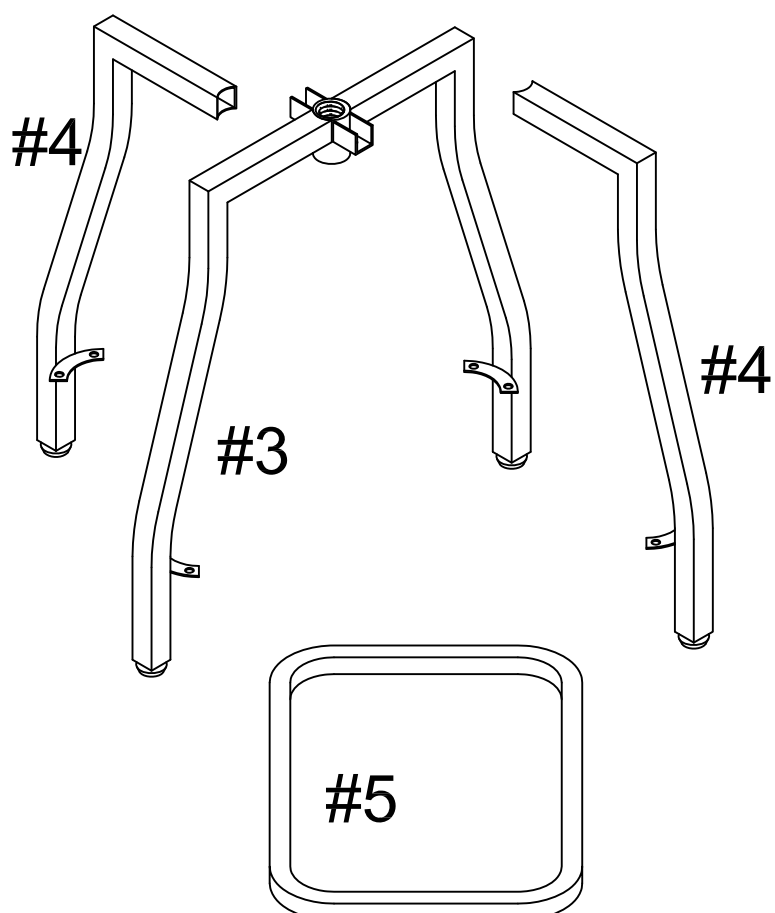
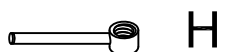
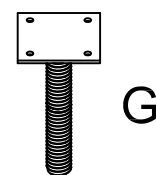
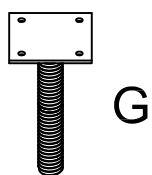
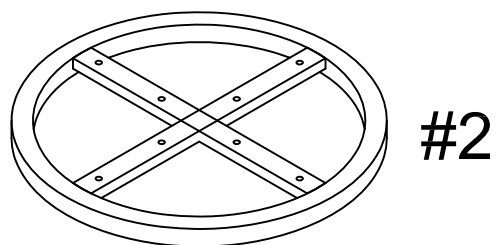
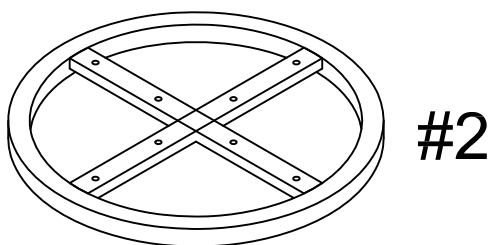
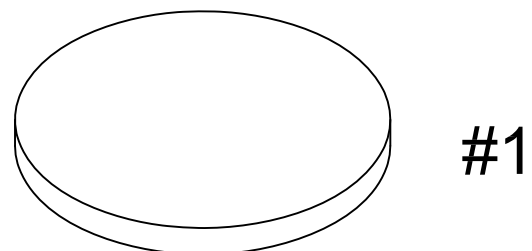
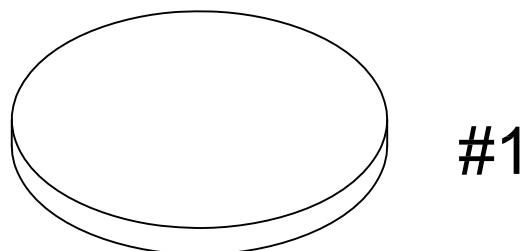

NOTE: DO NOT TIGHTEN ANY OF THE BOLTS UNTIL IS FULLY ASSEMBLED

NOTE:DO NOT TIGHTEN ANY OF THE BOLTS UNTIL FULLY ASSEMBLED

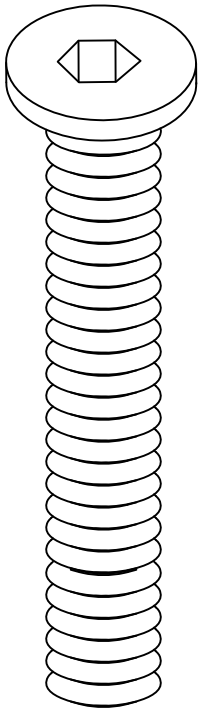

BOLT  
A x 8  
Ø1/4 \* 1-3/16"

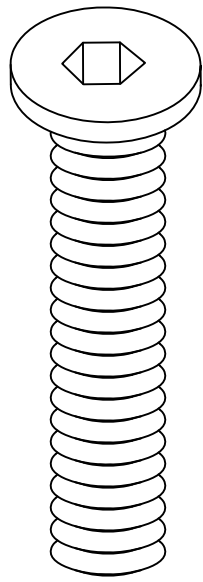

BOLT  
B x 8  
Ø1/4 \* 7/8"

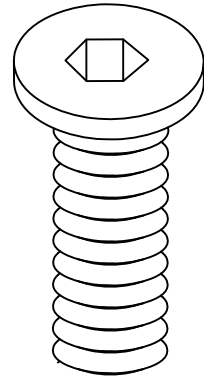

BOLT  
C x 22  
Ø1/4 \* 5/8"

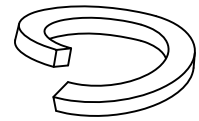

SPRING WASHER  
D x 36  
Ø1/4

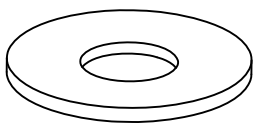

FLAT WASHER  
E x 36  
Ø1/4 \* 9/16"

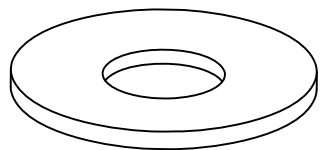

FLAT WASHER  
F x 2  
Ø1/4\*1-3/16"

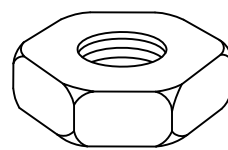

NUT  
G x 8  
Ø1/4

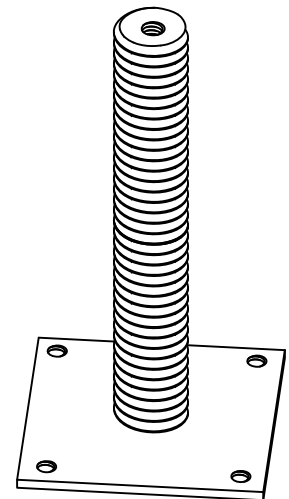

SUPPORT LONG BOLT  
H x 2

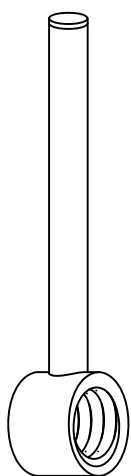

TIGHTENING HANDLE  
I x 2

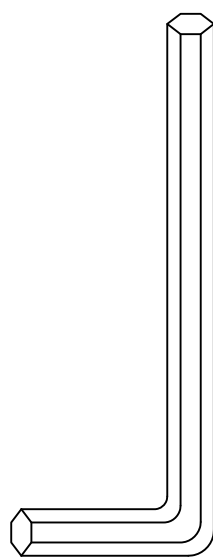

ALLEN KEY

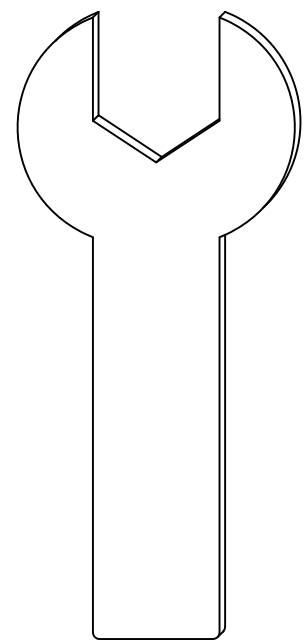

WRENCH

**NOTE: DO NOT TIGHTEN ANY OF THE BOLTS UNTIL FULLY ASSEMBLED**

1.  
X 2

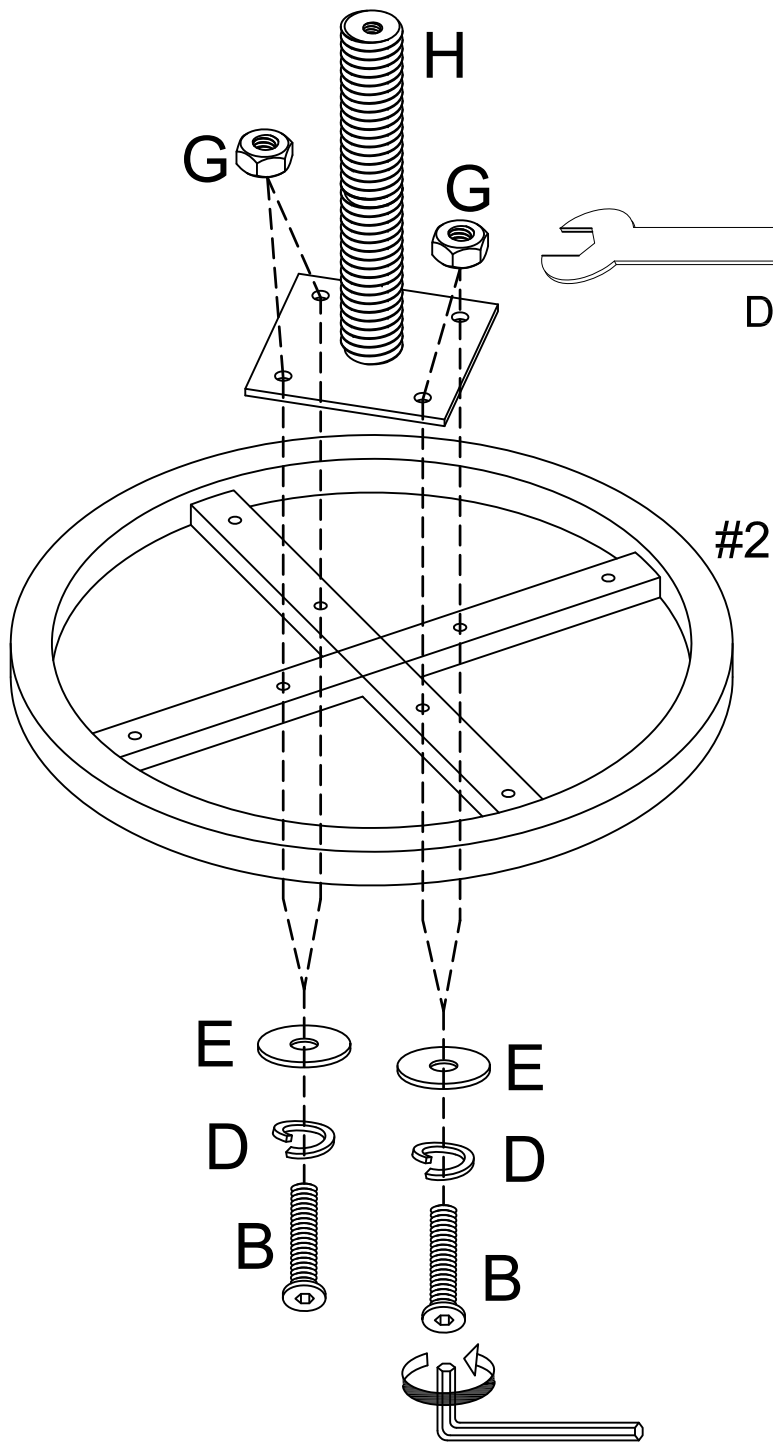

UP OF THE STEEL SEAT FRAME CONNECTED WITH THE WOOD SEAT BOARD (#1).  
DOWN OF THE STEEL SEAT FRAME CONNECTED WITH THE SUPPORT LONG BOLT (H).

B		4
D		4
E		4
G		4
H		1

2.  
X 2

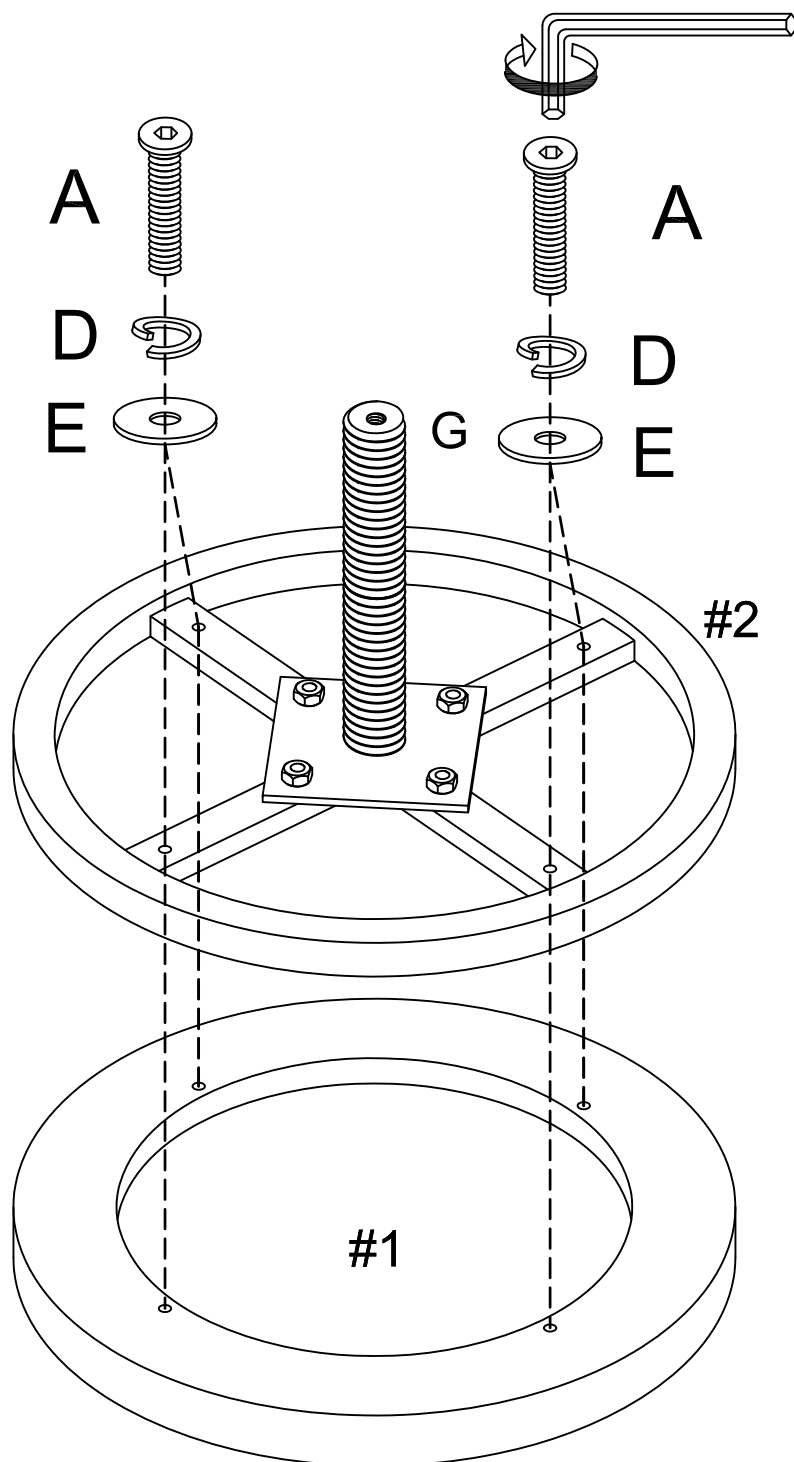



IT IS NOT RECOMMENDED TO USE A POWERFUL ELECTRIC TOOL

A		4
D		4
E		4

NOTE:DO NOT TIGHTEN ANY OF THE BOLTS UNTIL FULLY ASSEMBLED

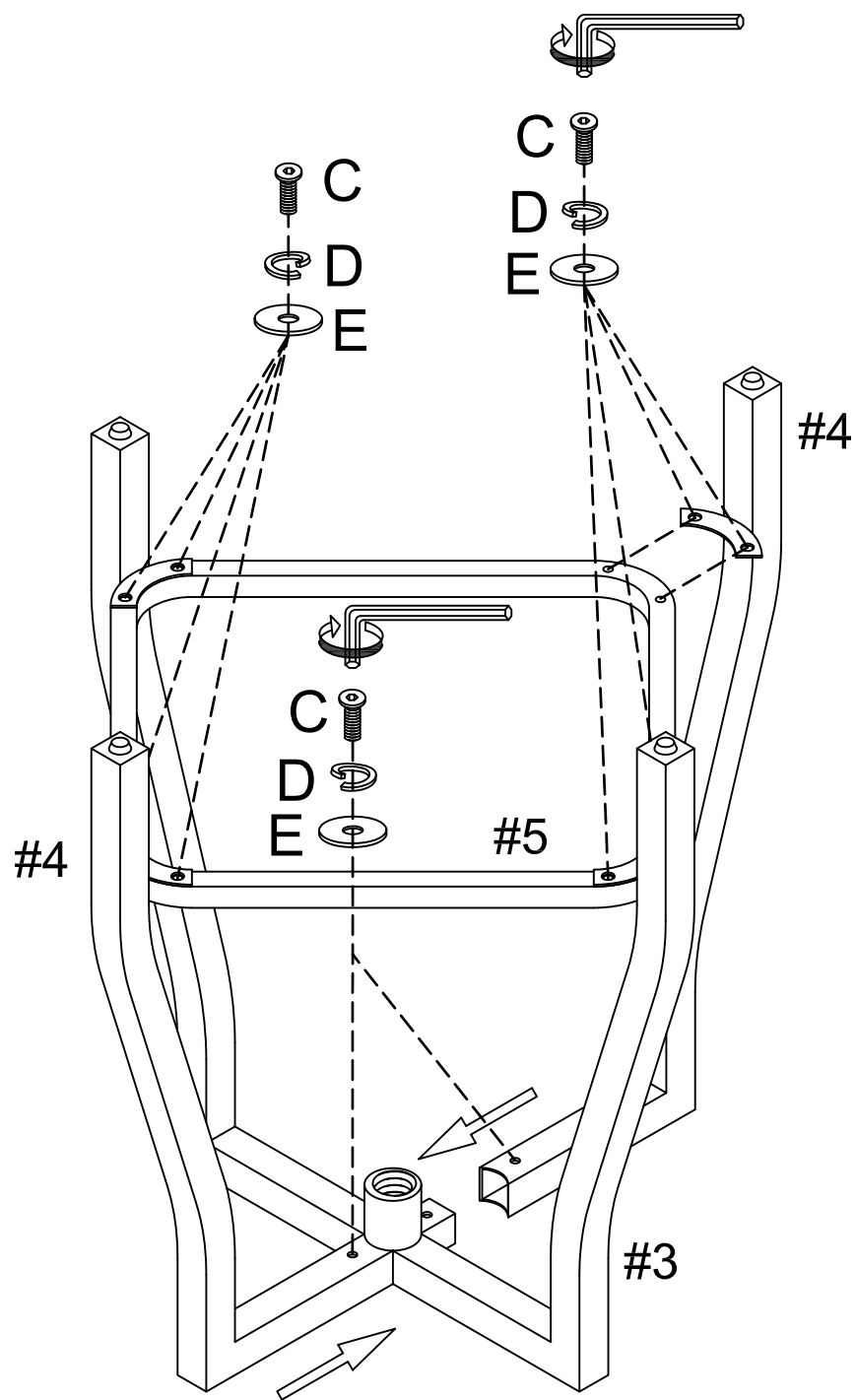
3.  
X 2

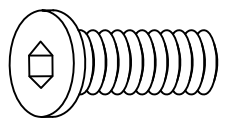
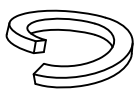

C		10
D		10
E		10

4.  
X 2

LEVELERS ARE PRE-ASSEMBLED. PLEASE ADJUST ON A FLAT AND LEVEL SURFACE AFTER COMPLETELY ASSEMBLED.

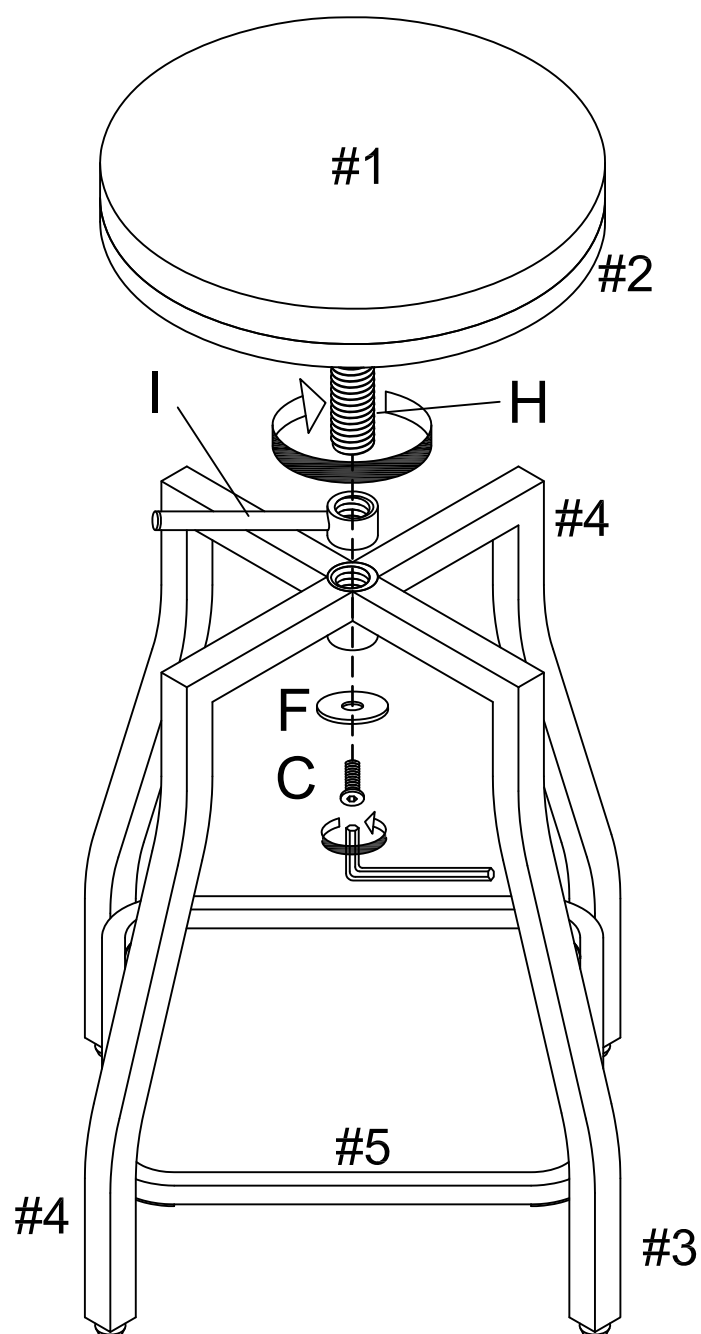

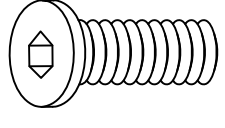
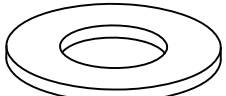
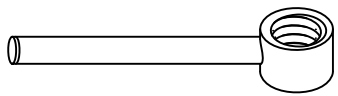
C		1
F		1
I		1